



US 20090158496A1

(19) **United States**

(12) **Patent Application Publication**  
**Roeckl**

(10) **Pub. No.: US 2009/0158496 A1**

(43) **Pub. Date: Jun. 25, 2009**

(54) **GLOVE WITH INFLATABLE AIR**

(30) **Foreign Application Priority Data**

(76) Inventor: **Stefan Roeckl, Seeshaupt (DE)**

Apr. 24, 2006 (DE) ..... 10 2006 018 941.8

Correspondence Address:

**LATIMER, MAYBERRY & MATTHEWS IP  
LAW, LLP  
13873 PARK CENTER ROAD, SUITE 106  
HERNDON, VA 20171 (US)**

**Publication Classification**

(51) **Int. Cl.**  
**A41D 19/00** (2006.01)

(52) **U.S. Cl.** ..... **2/161.1; 2/163; 2/167**

(21) Appl. No.: **12/298,343**

(22) PCT Filed: **Apr. 24, 2007**

(57) **ABSTRACT**

(86) PCT No.: **PCT/EP07/03594**

§ 371 (c)(1),  
(2), (4) Date: **Dec. 8, 2008**

The present invention provides a glove, in particular a winter sports glove, which includes an air chamber that is filled with air through at least one opening or through which air may circulate.

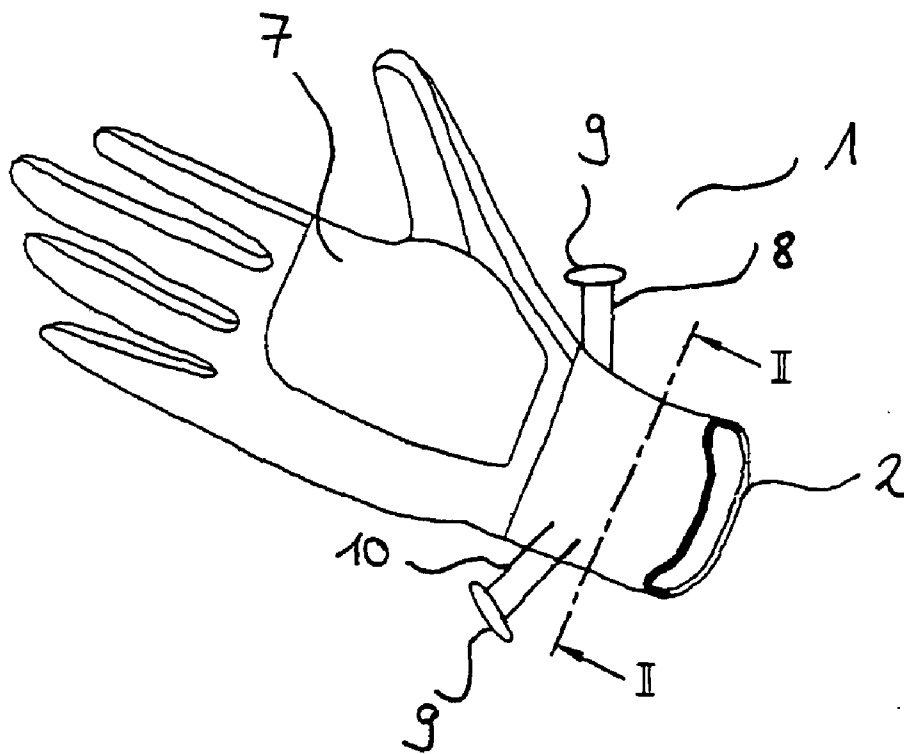

Fig. 1

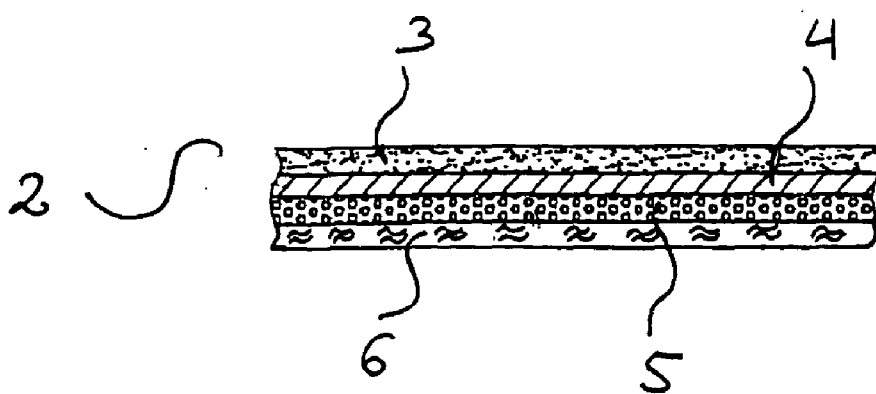

Fig. 2

**GLOVE WITH INFLATABLE AIR**

**CROSS-REFERENCE TO RELATED APPLICATIONS**

**[0001]** This application is a U.S. National Stage application of PCT/EP2007/003594, filed 24 Apr. 2007, the entire disclosure of which is hereby incorporated herein by reference.

**BACKGROUND OF THE INVENTION**

**[0002]** The present invention concerns a glove, in particular a winter sports glove, including an air chamber which is filled with air through at least one opening or through which air may circulate.

**[0003]** Generic gloves are known from the prior art RO29A04/P-DE14, dated February 2006. Such gloves are particularly used in winter for skiing and snowboarding in order to protect the hands against the cold.

**[0004]** Although these gloves were the object of successive improvement over the course of time, for example by the use of so-called climate membranes intended to prevent the penetration of moisture to the inside of the glove, the wearer of such gloves nevertheless very frequently still experiences cold hands and in particular cold fingers, particularly at low temperatures or in humid weather. This problem does, of course, also occur with motorcycle gloves, working gloves, or other gloves. In order to solve this problem, electrically heated clothing articles, such as gloves, are proposed in the prior art, e.g., in DE 81 11 943 U1 and DE 37 25 337 A1, wherein a source of electrical current is employed for the generation of heat. This solution does, however, detract from handling properties and wearing comfort. Furthermore, this solution depends on the provision of external energy sources, such as a battery. In addition, the use of such heating devices including batteries has the drawback that inhomogeneous heating or overheating will occur, with the heating intermittently having to be turned off as a result.

**SUMMARY OF THE INVENTION**

**[0005]** It is therefore an object of the present invention to furnish a glove which is capable of remedying the above-described cold problem by simple means.

**[0006]** In accordance with the invention, this object is achieved by creating an air chamber at least in one area of the glove, preferably in the upper hand part, whereby the property of air as an excellent insulator is being made use of.

**[0007]** Accordingly, the present invention concerns a glove, in particular a sports glove, having an upper hand part and an inner hand part which cover the palm of the hand, the back of the hand, and optionally the fingers of the wearer of the glove, characterized in that in at least one part of the hand, preferably in the upper hand part, an air chamber is present, into which at least one opening for inflating air into the inside of the air chamber extends from the outside.

**[0008]** In the prior art, gloves were proposed into which air may be blown through a valve to thus warm one's hand; see, for example, German Utility Model DE 200 15 105 U1. The inherent drawback here does, however, reside in the fact that the exhaled air is humid so that the glove may turn damp. Furthermore, it is not possible to warm one's hand during a sporting activity. Finally, mostly only a limited range of the hand is heated for a short period of time by blowing through air.

**[0009]** In contrast, by using an air chamber in accordance with the present invention, when warm exhaled air is blown in, it is not supplied directly to the hand, but a warming and insulating layer is formed in the glove to thus create a cushion of heated air. Thanks to the configuration of the glove in accordance with the invention so as to include an air chamber, the glove lining contacting the hand remains dry, and the glove can not turn damp any more.

**[0010]** This air cushion, in the following alternatively referred to as an air chamber, typically extends from the back of the hand to preferably across the individual fingers and is inflatable with the aid of an opening, preferably a valve, at the back of the hand. In other embodiments of the glove of the invention, the air chamber may also extend across the inner side of the hand as far as over the fingers or parts thereof.

**[0011]** The air chamber in the glove is preferably situated between the inner lining of the glove and the material layer terminating to the outside, for instance an exterior leather, with the material layers of the air chamber in one embodiment being configured such that these very material layers form the glove's outer and/or inner terminating layer.

**[0012]** The glove of the invention is provided with at least one opening, preferably at the glove's closure band, through which air may enter into the inside of the air chamber.

**[0013]** In a preferred embodiment, the inner material layer of the air chamber, which faces the hand, possesses the properties of a semi-permeable membrane, i.e., its permeability to air and humidity is selective. Hereby humidity is prevented from penetrating to the inside of the glove. There is furthermore a tendency of the hands to develop sweat in the event of physical exertion, for instance during skiing, so that the inside of the glove may as a result become humid and produce the sensation of cold hands. Thanks to the use of a semi-permeable membrane possessing a corresponding selectivity, such humidity may be discharged via the air chamber and the inlet openings and optionally outlet openings present on the glove. Semi-permeable membranes are known per se, in particular of polytetrafluoroethylene (PTFE), and/or a laminate formed of polyvinyl chloride, polyurethane, polyether amide, polyetherester amide, polyolefin components, polyester components, or a mixture thereof. Particularly preferred are polytetrafluoroethylene (PTFE), in particular Gore-tex material, preferably brand products such as Aktivent, DryLoft, Gore-Tex (GTX), and Windstopper-GTX.

**[0014]** In one advantageous configuration of the glove of the invention, another material layer, which preferably is contour-conforming, is present on the side of the inner material layer of the air chamber facing the hand. In this regard, particularly textile materials are conceivable, but also leather and leather imitations. In one embodiment, the another material layer is substantially comprised of nonwoven fabric providing pleasant wearing comfort for winter sports gloves in particular. Furthermore it is evident from the above enumeration of materials for the another material layer that the use of breathing, air-permeable materials is preferred.

**[0015]** In an advantageous development of the glove of the invention, it may be provided for the at least one opening to be furnished with an element for closing the opening. Thus, on the one hand the air chamber may be closed following blowing in of the air in order to maintain an air cushion, and on the other hand humidity can be prevented from penetrating into the air chamber.

**[0016]** In a preferred embodiment, this element for closing the at least one opening has the form of a valve. In order to

keep humidity contained in the inflated, exhaled air away from the inside of the glove, it may be provided in another advantageous configuration of the glove of the invention to furnish a membrane preventing the penetration of humidity into the air chamber in the valve.

**[0017]** When the at least one opening is disposed at the termination of the glove, in particular on the upper hand part of the glove, it interferes the least with the functionality of the glove while also hardly impairing the visual quality of the glove. In this location the opening—and a valve optionally associated with the opening—is not considered to be interfering and is very easily accessible to the mouth.

**[0018]** In another embodiment, the glove of the invention includes at least one second opening, which may be configured just like the at least one opening described in the foregoing. This embodiment is particularly advantageous when the air chamber is configured such that its inner material layer is air-permeable, so that a stream of air may reach the palm and/or the fingers of the glove's wearer while the openings are open. In one embodiment, the glove of the invention may be configured to include at least two air chambers, either as entirely separate units, or separated, for example, by a membrane starting out from one air chamber, with the two air chambers including a semi-permeable membrane, which is air-permeable, as an inner material layer, and each one of the two air chambers including at least one opening so as to permit the formation of a stream of air across the inner material layer and the hand of the glove's wearer across the inner material layer of the second air chamber as far as to the discharge opening of the latter when air is blown into the one air chamber while the openings for both air chambers are opened. In this configuration of the glove of the invention, the at least one second opening or the at least one opening of the second air chamber is preferably situated in the area of the termination of the inner hand part, particularly if the at least one first opening of the optionally present first air chamber has a corresponding arrangement on the upper hand part.

**[0019]** However, the desired circulation of air need not inevitably be brought about by the presence of at least one second opening, for instance if the opening used by the wearer of the glove for inserting his hand may serve as such at least one second opening.

**[0020]** The embodiment described in the foregoing is particularly advantageous for summer activities, for external air may then reach the hand and bring about cooling of the hand in the opened condition of the valves. In this case it may also be an option to configure the at least one opening in the manner of a radiator grille for taking in "running wind", particularly if the at least one opening is disposed on the upper hand part of the glove.

**[0021]** In the warm season, a capability of lowering the body temperature is desirable, wherein it should be attempted to dissipate heat to the environment. If it is not possible to carry off heat in a sufficient degree by conduction or heat flow, the body makes use of evaporation, in which case the result is perspiration. In order to be able to ensure the well-being of the body, it is advantageous to keep away the humidity forming in the process, as is achieved through the use of a semi-permeable membrane (see element **5** of FIG. **2**, for example) in combination with the air chamber of the invention.

**[0022]** As is evident from the above discussion, the glove of the invention is suited in particular for the performance of outdoor activities such as winter sports, in particular skiing, snow-mobiling, cross-country skiing, Nordic Walking, but

also for other kinds of sports such as hiking, trekking, mountaineering, etc. Nevertheless the glove of the invention is not limited to these types of sports but may in particular preferably also be used in the embodiments for summer sports mentioned last, particularly those in which cooling or ventilation of the hand is desired.

**[0023]** Particularly in the performance of winter sports such as skiing or snowboarding it is advantageous if the glove comprises an outer material layer such as shell material which protects the glove or the wearer's hand against external influences such as impacts or extreme weather conditions. In another preferred embodiment of the glove of the invention, the latter thus comprises as an outer material layer an insulation or insulating layer which is preferably comprised of a substantially weather-resistant and optionally impact-resistant material or includes corresponding areas, respectively. Corresponding materials are known to the person having skill in the art and include, for example, synthetics and compression-resistant elements of other materials.

**[0024]** Furthermore, the air chamber in accordance with the invention, as described in the foregoing and explained in the following practical example, may fundamentally be employed in pieces of equipment intended to at last temporarily cover parts of the body, in particular pieces of clothing, blankets, sleeping-bags and other clothing articles that are suited for the accommodation of extremities. In this regard, the present invention also relates to a piece of equipment which contains an air chamber in accordance with the invention and which provides an opening for admitting air as described in the foregoing.

**[0025]** Conceivable pieces of equipment in accordance with the invention in particular are clothing articles, in particular gloves for the upper extremities, socks, shoes, boots, trousers, underwear for the lower extremities, hood, cap, hat, mask for the head, and jacket and coat for the torso.

BRIEF DESCRIPTION OF THE DRAWINGS

**[0026]** In the following, the invention shall be explained in more detail by referring to the practical examples represented in the drawings, wherein:

**[0027]** FIG. **1** is a top view of a glove of the invention.

**[0028]** FIG. **2** is a sectional view of an air chamber having several layers of material.

DETAILED DESCRIPTION OF EXEMPLARY EMBODIMENTS

**[0029]** FIG. **1** is a schematic representation of a glove (**1**) having an air chamber (**2**) integrated into the upper hand part of the glove and indicated by an open line for the sake of simplicity. In a manner known per se, the glove (**1**) additionally includes an opening for inserting the hand, an area for accommodating the palm of the hand (not represented), and an area for accommodating the fingers, which is also not represented. In the following case, the glove (**1**) is intended for skiing or snowboarding; however it may, of course, also be a matter of some other sports glove or of a glove for any other function, as well as a garment or fashion glove.

**[0030]** The glove (**1**) in accordance with FIG. **1** is provided with a first opening (**8**) and optionally with a second opening (**10**). In the present case, the air chamber (**2**) extends across the entire upper hand part of the glove. By means of the exhaled air blown into the air chamber (**2**) via the at least one opening (**8**), the upper hand and the fingers inside the glove

(1) are warmed through the formation of a "heat cushion" or protected against the cold by the insulating layer thus obtained.

[0031] It can furthermore be seen that the at least one opening (8) is provided with an element (9) for closing the at least one opening (8) which in the present case has the form of a valve. In a manner not represented, a membrane for preventing the penetration of humidity into the inside of the glove may be arranged in the valve. By blowing via the at least one opening (8) provided with a valve into the air chamber (2), a warm-air cushion is produced which keeps the hand warm or insulates it against the cold even after the warm air was blown in and while engaging in a sport. This serves to mitigate the problem of cold hands during the sporting activity which has been occurring in any gloves up to the present day.

[0032] In contrast with the present representation, an air chamber having an opening (10) and suited to be filled with warm exhaled air may alternatively or additionally also be arranged on the inner side of the hand.

[0033] As is shown in the representation of FIG. 1, the at least one opening (8) or the at least one second opening (10) is preferably provided at the glove's closure band, approximately in the location where a wrist-watch is customarily worn. What is not represented here is the circumstance that the respective at least one opening (8) or at least one second opening (10) need not open directly into the air chamber but is optionally connected to the air chamber with the aid of a suitable conduit.

[0034] In contrast to the present representation, the glove (1) may also be configured to have only two finger parts, i.e., as a mitten.

[0035] FIG. 2 shows a sectional view of an air chamber (2) in accordance with the invention, wherein the latter is comprised of several layers of material. The person having skill in the art is readily aware that the air chamber (2) will usually have a configuration avoiding a direct surface contact of the terminating layers of material even when no air is inflated, for otherwise they might "stick" to each other as a result of humidity possibly being blown in, but that a possible adhesion or "sticking" of the material layers to each other may be avoided by the use of "spacers", for example. Such "spacers" may include, for example, materials such as cellular material or nonwoven fabric or sponge rubber. An air chamber (2) in accordance with the invention substantially includes an outer material layer (3) of a woven and/or knitted material or synthetic film that is substantially air-impermeable, a cavity (4) for receiving the exhaled air, an inner material layer (5), for example, of a semi-permeable membrane, and optionally an additional material layer (6) of a woven and/or knitted material, for example a nonwoven. In the case of a semi-permeable membrane, the inner material layer (5) may be formed, for example, of polytetrafluoroethylene (PTFE), in particular of Gore-Tex. However, other materials having air-permeable properties are equally conceivable. As an alternative the inner material layer (5) is also substantially air-impermeable if a circulation of air with the area of the inner hand is not desired. Materials in particular suited for the formation of the inner material layer and optionally of successive further material layers of the air chamber may also be found in German Utility Model DE 20 2005 008 041.

[0036] With regard to the figures, the following is a List of Reference Numerals:

- [0037] 1. glove
- [0038] 2. air chamber

- [0039] 3. outer material layer
- [0040] 4. cavity of the air chamber
- [0041] 5. inner material layer (membrane)
- [0042] 6. nonwoven
- [0043] 7. palm of the hand
- [0044] 8. opening (back of the hand; "at least one opening")
- [0045] 9. closure element (valve)
- [0046] 10. opening (inner side of the hand; "at least one second opening")

1. A glove including an upper hand part and an inner hand part which cover the palm of the hand, the back of the hand, and optionally the fingers of the glove's wearer, characterized in that at least in one part of the hand an air chamber is present into which at least one opening for inflating air into the inside of the air chamber extends via an outer material layer.

2. The glove according to claim 1, wherein the inner material layer of the air chamber, which faces the hand, comprises a semi-permeable membrane.

3. The glove according to claim 1, wherein at least the inner material layer facing the hand substantially includes polytetrafluoroethylene (PTFE) and/or a laminate formed of polyvinyl chloride, polyurethane, polyether amide, polyetherester amide, polyolefin components, polyester components, or a mixture thereof.

4. The glove according to claim 1, wherein the inner material layer of the air chamber is followed by another material layer.

5. The glove according to claim 4, wherein the another material layer is comprised of textile material.

6. The glove according to claim 4, wherein the another material layer is substantially comprised of nonwoven fabric.

7. The glove according to claim 4, wherein the another material layer is comprised of a breathing, air-permeable material.

8. The glove according to claim 1, wherein the at least one opening is provided with an element for closing the opening.

9. The glove according to claim 8, wherein the element for closing the at least one opening has the form of a valve.

10. The glove according to claim 9, wherein a membrane for preventing the penetration of humidity to the inside of the glove is arranged in the valve.

11. The glove according to claim 1, wherein the at least one opening is arranged below the area for accommodating the palm of the hand.

12. The glove according to claim 1, wherein the at least one opening is arranged on the upper hand part.

13. The glove according to claim 1, wherein at least one second opening is provided.

14. The glove according to claim 13, wherein the at least one second opening is configured like the at least one opening.

15. The glove according to claim 13, wherein the at least one second opening is disposed in the area of the inner hand part.

16. The glove according to claim 13, characterized in that a stream of air via the outer material layer into the inside of the inner hand part, which reaches the user's hand, may form when the at least one opening is open.

17. The glove according to claim 16, wherein the at least one opening is configured in the manner of a radiator grille.

18. The glove according to claim 1, which is suited for the performance of winter sports, in particular skiing.

19. The glove according to claim 1, comprising an insulation material as the outer material layer.

**20.** An air chamber as recited in claim **1**, for a piece of equipment intended to at least temporarily cover parts of the body.

**21.** A piece of equipment including an air chamber according to claim **20** and at least one opening for admitting air.

**22.** A piece of equipment according to claim **21**, wherein the latter is used as a clothing article for the upper extremities.

\* \* \* \* \*