

(21) Application No: 1111215.8

(22) Date of Filing: 30.06.2011

(71) Applicant(s):  
Cambridge Display Technology Limited  
(Incorporated in the United Kingdom)  
Building 2020, Cambourne Business Park,  
Cambridgeshire, CB3 6DW, United Kingdom

(72) Inventor(s):  
Euan Smith

(74) Agent and/or Address for Service:  
Cambridge Display Technology Limited  
IP Department, Building 2020,  
Cambourne Business Park, Cambridgeshire,  
CB23 6DW, United Kingdom

(51) INT CL:  
H01L 51/52 (2006.01) H01L 27/32 (2006.01)  
H05B 33/22 (2006.01)

(56) Documents Cited:  
WO 2009/078198 A WO 2007/097558 A  
WO 2002/015292 A FR 002858859 A

(58) Field of Search:  
INT CL G02B, G02F, G09F, H01L, H05B  
Other: EPODOC, WPI

(54) Title of the Invention: **Display device**  
Abstract Title: **Display device**

(57) A display device comprises an array of organic light emitting diode (OLED) pixels 1 which emit light towards a viewing surface 3, a light-transmissive, light scattering layer 5 in the path of light from the pixels towards the viewing surface 3, and a light baffle 22 located adjacent the viewing surface 3. The light baffle 22 comprises reflective walls arranged to extend in a direction from the viewing surface towards the scattering layer. The walls are arranged to reflect light rays which have been totally internally reflected at the viewing surface back towards the scattering layer 15. The walls are configured to have an aspect ratio defined as the ratio of the separation between adjacent walls to the height of the walls, having a value between 1.5:1 and 2:1. The scattering layer improves efficiency, whilst the light baffle reduces blurring caused by scattered light which has been reflected internally.

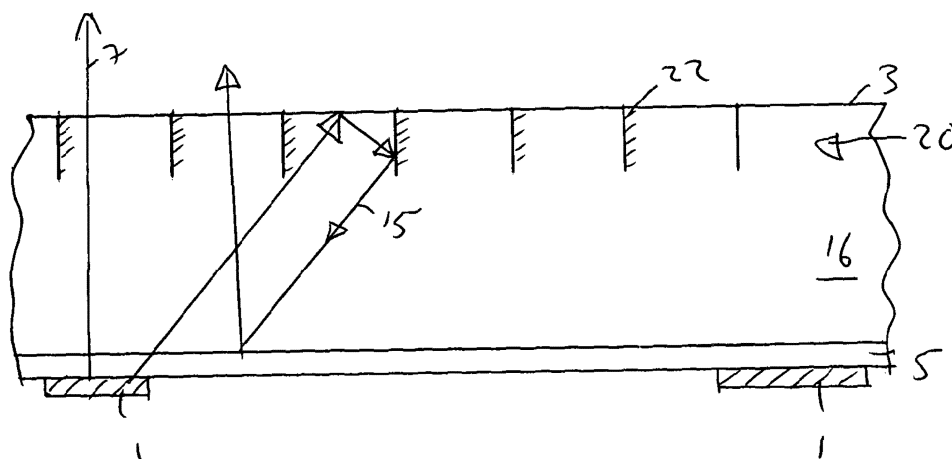

FIGURE 2

At least one drawing originally filed was informal and the print reproduced here is taken from a later filed formal copy.

This print takes account of replacement documents submitted after the date of filing to enable the application to comply with the formal requirements of the Patents Rules 2007.

1/2

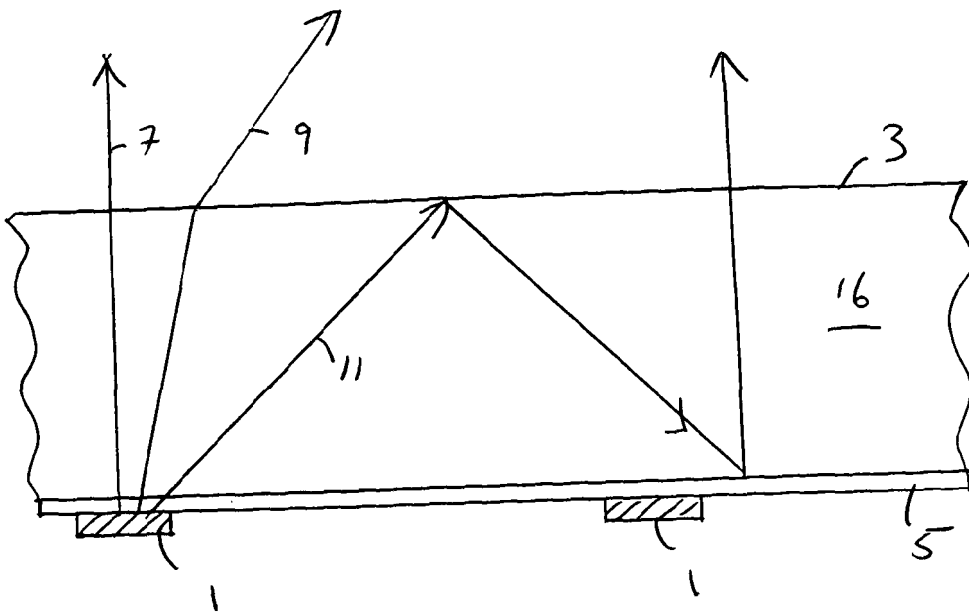

FIGURE 1

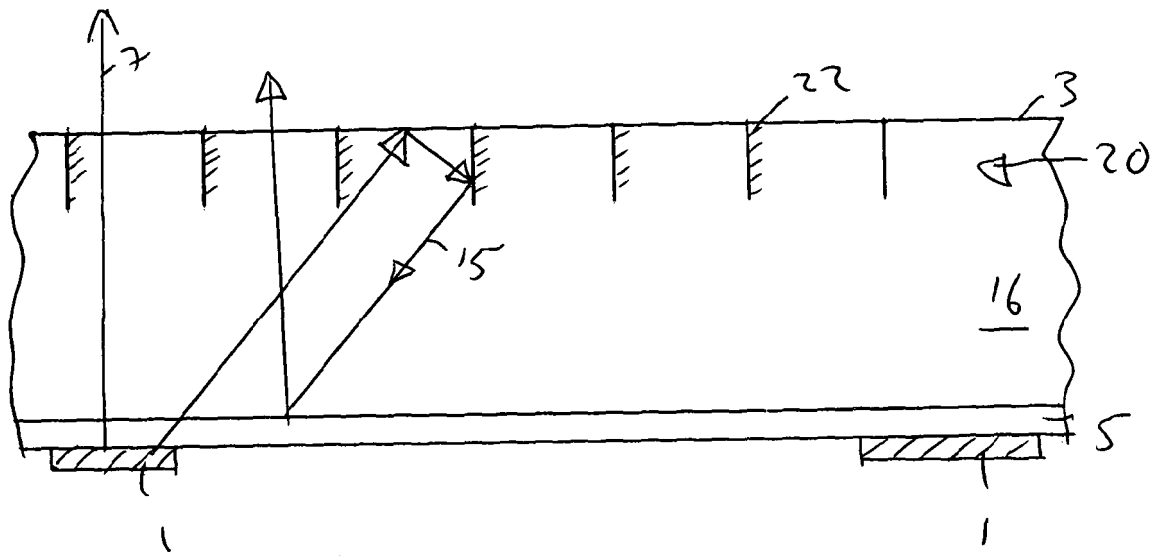

FIGURE 2



2/2

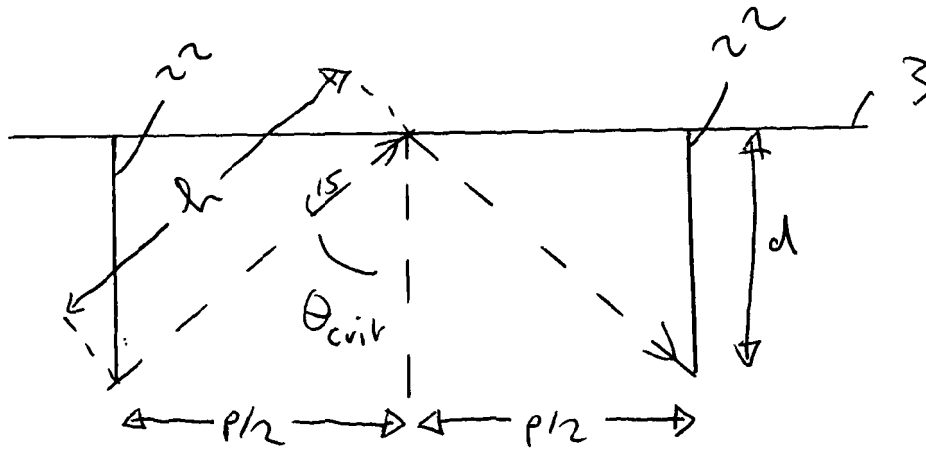

FIGURE 3



## DISPLAY DEVICE

### BACKGROUND TO THE INVENTION

This invention generally relates to display devices. More particularly the invention relates to display devices having organic electroluminescent pixels, such as for example Organic Light Emitting Diode (OLED) display devices.

Organic light emitting diodes (OLEDs) comprise a particularly advantageous form of electro-optic display. They are bright, colourful, fast switching, provide a wide viewing angle and are easy and cheap to fabricate on a variety of substrates.

Organic (which here includes organometallic) LEDs may be fabricated using either polymers, non-polymeric molecules or dendrimers in a range of colours, depending upon the materials used. Examples of polymer-based organic LEDs are described in WO 90/13148, WO 95/06400 and WO 99/48160; examples of non-polymeric molecule based devices are described in US 4,539,507 and examples of dendrimer-based materials are described in WO99/21935 and WO02/067343.

A basic structure of a typical organic LED involves a glass or plastic substrate supporting a transparent anode layer comprising, for example, indium tin oxide (ITO) on which is deposited a hole transport layer, an electroluminescent layer and a cathode. The electroluminescent layer, may comprise, for example, PEDOT: PSS (polystyrene-sulphorate - doped polyethylene - dioxythiophene). The cathode layer typically comprises a low work function metal such as calcium and may include an additional layer immediately adjacent electroluminescent layer, such as a layer of aluminium, for improved electron energy level matching. Contact wires to the anode and the cathode respectively provide a connection to a power source. The same basic structure may also be employed for small

molecule devices. In this structure, light can be emitted through the transparent anode and substrate and devices with this structure are referred to as "bottom emitters". Devices which emit through the cathode may also be constructed, for example, by keeping the thickness of the cathode layer to less than around 50-100nm so that the cathode is substantially transparent.

Organic LEDs may be deposited on a substrate in a matrix of pixels to form a single or multi-colour pixellated display. A multi-coloured display may be constructed using groups of red, green and blue emitting pixels. Pixels emitting different colours need not have equal areas.

In such displays the individual elements are generally addressed by activating row (or column) lines to select the pixels, and rows (or columns) of pixels are written to, to create a display. So-called active matrix displays have a memory element, typically a storage capacitor and a transistor, associated with each pixel whilst passive matrix displays have no such memory element and instead are repetitively scanned, somewhat similarly to a CRT picture, to give the impression of a steady image.

#### SUMMARY OF THE INVENTION

According to a first aspect of the present invention, there is provided a display device as specified in claim 1.

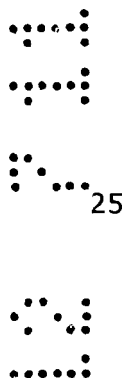

The display device comprises an array of electroluminescent pixels for emitting light towards and through a viewing surface in use, a light-transmissive light scattering layer in the path of light from the pixels towards the viewing surface, and a light baffle located adjacent the viewing surface, the light baffle comprising reflective walls arranged to extend in a direction from the viewing surface towards the scattering layer, the walls being configured to reflect light rays which have been

totally internally reflected at the viewing surface back towards the scattering layer.

Advantageously, the scattering layer can improve efficiency, whilst the light baffle can reduce blurring caused by scattered light which has been reflected internally towards adjacent pixels. The arrangement also provides a display which can have a flat front viewing surface.

Preferably, the light baffle comprises a film, for example a louver film. A louver film can be applied on the front surface of a display using a contact adhesive, and comprises light reflecting walls or louvers spaced apart from one another adjacent the viewing surface, arranged to reflect total internally reflected light back towards the scattering layer and the pixel from which the light was originally emitted.

Other preferred arrangements are described in the dependent claims.

The present invention is particularly suitable for integration as part of an Organic Light Emitting Diode (OLED) display device.

#### DESCRIPTION OF THE PRIOR ART

An LED display device having a louver film on the front surface is described in JP 2000-029406. In this device the louver film is used to reduce reflection of ambient light from the front surface of the display and the louvers absorb light.



It is also known to attach louver films to the front surface of an LCD display to restrict the viewing angle and thus act to enhance privacy by preventing neighbouring people from seeing what is being displayed (see for example WO 2009/050505).

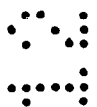

In the present invention, the aspect ratio, defined as the ratio of the separation between adjacent walls to the height of the walls, has a value between 1.5:1 and 2:1, preferably between 1.7:1 and 1.9:1. Thus, the

louvers do not significantly restrict the viewing angle of the display device, as the light at large angles will be totally internally reflected anyway. This is in contrast to the common use of louver films as privacy filters where the viewing angle of a display is deliberately reduced.

- 5 Another LED display having a scattering layer and light absorbing walls is described in US2008/0061687, but here the walls are light absorbing, and they are not located at the viewing surface of the display.

#### BRIEF DESCRIPTION OF THE DRAWINGS

- 10 Embodiments of the invention will now be described, by way of example only, with reference to the accompanying drawings, in which:

Figure 1 shows a cross-section of a pixellated display having a scattering layer adjacent the light emissive pixels.

- 15 Figure 2 shows a cross-section of the display of Figure 1 further comprising a light baffle consisting of reflective walls (22).

Figure 3 shows a diagram explaining how the aspect ratio of the walls  $p/d$  can be calculated from a knowledge of the refractive index ( $n$ ) of the light transmissive body of the display (16).

20

#### DETAILED DESCRIPTION

25

Figure 1 shows a diagrammatic cross-section of a display device having an array of electroluminescent pixels (1), and a transparent sheet (16) forming a front viewing surface (3) of the display. The array of pixels is arranged on the opposite side of the transparent sheet to the viewing surface, so that the pixels can be seen through the viewing surface in use.

30

A scattering layer (5) is provided adjacent the array of pixels. The scattering layer is arranged in the path of light emitted from the pixels

35

towards the viewing surface. The scattering layer is light-transmissive, so that the light emitted by the pixels passes through the scattering layer on its journey towards the viewing surface (3) of the display through the transparent sheet (16). The scattering layer may be provided on the side of the transparent sheet (16) facing the pixels. The scattering layer (5) can be made, for example, by coating the surface of the transparent sheet (16) with a layer of  $\text{TiO}_2$  or other particles in a transparent resin such as polycarbonate or PMMA. Alternatively, it can be provided on the top surface of the pixels.

10 The pixels in the present embodiment include organic electroluminescent material, forming part of an Organic Light Emitting Diode (OLED) display device.

The light rays passing through the scattering layer (7, 9, 11) are scattered through different angles whilst passing through the scattering layer. The light rays 7 and 9 pass through the viewing surface, but light ray 11 is totally internally reflected at the viewing surface/air interface because the angle of incidence at the viewing surface ( $\theta$ ) is greater than the critical angle ( $\theta_{\text{crit}}$ ). This ray is therefore reflected back towards the scattering layer at a point laterally spaced from the pixel from which the light ray was emitted.

The scattering layer scatters this ray back towards the viewing surface at a smaller angle of incidence so that it passes through the viewing surface at a point (12) laterally spaced from the pixel from which the light was originally emitted. This causes blurring of the display, but increases the light output from the display, as light which would have been totally internally reflected has been scattered out of the layer through multiple scattering events.

Figure 2 shows an OLED display according to the present invention, in which a light baffle (20) is located adjacent the viewing surface, the light baffle comprising reflective walls (22) extending in a direction from the

viewing surface towards the scattering layer, the walls being configured to reflect light rays (15) which have been totally internally reflected at the viewing surface back towards the scattering layer in the vicinity of the pixel from which the light rays were originally emitted. The reflective walls together with the viewing surface act like a retroreflector, and reflect the totally internally reflected light rays back towards their source. However, unlike a conventional corner cube retroreflector, the light baffle of the present invention retains a flat viewing surface by using parallel reflective walls (22).

10 When the totally internally reflected light ray (15) impinges upon the scattering layer adjacent the original pixel (1) from which it was emitted, it can be scattered towards the viewing surface again at an angle of incidence sufficiently small for it to be transmitted on this occasion through the viewing surface. Because the light ray has been returned to a point close to the original pixel, this light will not be emitted from a position laterally spaced from the original pixel. And therefore there will be less blurring of the display or cross talk between neighbouring pixels. Thus the display having both the scattering layer (5) and the light baffle (20) has an improved performance relative to the display of Figure 1 which has no light baffle.

The height of the walls in the light baffle is selected to be sufficient to reflect rays which have been totally internally reflected, but not high enough to unduly restrict the viewing angle of the display. The optimum height of the walls relative to their separation to achieve this balance will now be calculated.

If we assume that the refractive index of the transparent body (16) of the display between the scattering layer and the viewing surface is  $n$ , and that the refractive index of the air outside the display is 1, then the angle of incidence beyond which total internal reflection occurs (the critical angle ( $\theta_{crit}$ )). is given by the expression  $n \times \sin (\theta_{crit}) = 1$ , and so  $\sin (\theta_{crit}) = 1/n$ .

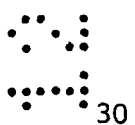
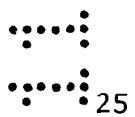

From Figure 3, it can be seen that the height (d) of the walls 22 will be given by  $\cos(\Theta_{\text{crit}}) = d/h$ , therefore  $d = h \times \cos(\Theta_{\text{crit}})$ . Half the pitch (p) between the walls will be given by  $p/2 = h \times \sin(\Theta_{\text{crit}})$ . Thus the aspect ratio p/d is equal to  $[2h \times \sin(\Theta_{\text{crit}})]/[h \times \cos(\Theta_{\text{crit}})]$  which is equal to  $2[\sin(\Theta_{\text{crit}}) / \cos(\Theta_{\text{crit}})]$ . Substituting a value of  $n = 1.5$  (the refractive index of the body (16) will in general be close to that of glass or a plastic material such as polycarbonate) one gets an optimum aspect ratio p/d of 1.8. Thus the aspect ratio is preferably in the range between 1.5 and 2, more preferably between 1.7 and 1.9.

The light baffle may be provided on one side (i.e. viewing surface) of a transparent sheet (16) – i.e. the side opposite to that facing the pixels (1). A method of making a louver film having elongate reflective louver members suitable for affixing to the viewing surface of the sheet is disclosed, for example, in US2006/0176556.

It is important, if the light baffle consists of a louver film attached to the viewing surface of a display device, that the transparent part of the louver film has a refractive index matched to that of the transparent body (16) to which it is affixed. Also, if it is affixed using a transparent adhesive layer, such as a UV curing optical adhesive, that the refractive index of the adhesive is chosen to match both the refractive index of the transparent part of the louver film and the transparent body. Suitable UV curing optical adhesives having a variety of refractive indexes are available, for example, from Norland Products, New Jersey, USA.

Preferably, the reflective walls or louver members extend in a direction parallel to one another, the viewing surface is flat, and the reflective walls extend in a direction substantially normal to the viewing surface, or in a direction having a significant component normal to the viewing surface.

In finished display devices, the pixels will be connected to driver circuitry to drive the pixels in response to video input signals, or the like. As such circuitry and OLED devices in general are well known in the art, they are

not described here in detail. Further information on conventional OLED materials and devices can be found in a variety of textbooks, such as "Organic Light-Emitting Materials and Devices" edited by Zhigang Li and Hong Meng, published by CRC Press (Taylor and Francis)2007 (ISBN 10: 1-57444-574-X).

5

It will be appreciated that although only a few particular embodiments of the invention have been described in detail, various modifications and improvements can be made by a person skilled in the art without departing from the scope of the present invention as defined in the following claims.

10

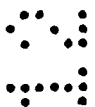
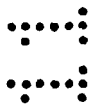

## CLAIMS

1. A display device having a viewing surface, the display device including an array of electroluminescent pixels for emitting light through the viewing surface in use, a light-transmissive light scattering layer in the path of light from the pixels towards the viewing surface, and a light baffle located adjacent the viewing surface, the light baffle comprising reflective walls arranged to extend in a direction from the viewing surface towards the scattering layer, the walls being configured to reflect light rays which have been totally internally reflected at the viewing surface back towards the scattering layer.
2. A display device as claimed in claim 1, in which the light baffle comprises a film including louvers provided at the viewing surface of the display.
3. A display device as claimed in any preceding claim in which the walls are configured to have an aspect ratio, defined as the ratio of the separation between neighbouring walls to the height of the walls, having a value between 1.5:1 and 2:1.
4. A display device as claimed in claim 3, in which the walls are configured to have an aspect ratio having a value between 1.7:1 and 1.9:1.
5. A display device as claimed in any preceding claim in which the reflective walls extend in a direction parallel to one another.
6. A display device as claimed in any preceding claim in which the viewing surface is flat, and the reflective walls extend in a direction normal to the viewing surface.

5

10

15

20

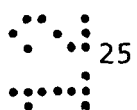

25

7. A display device as claimed in any preceding claim in which the pixels comprise an organic electroluminescent material.
8. A display device as claimed in any preceding claim further comprising control circuitry to drive the pixels in response to input data signals.

5

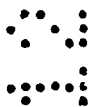
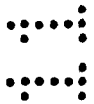

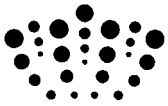

**Application No:** GB1111215.8

**Examiner:** Ms Anna Brandon

**Claims searched:** 1 to 8

**Date of search:** 25 October 2011

**Patents Act 1977: Search Report under Section 17**

**Documents considered to be relevant:**

Category	Relevant to claims	Identity of document and passage or figure of particular relevance
X	1, 5 to 8	WO2002/15292 A (EMAGIN) Fig. 3
A	none	WO2009/078198 A (SHARP)
A	none	WO2007/097558 A (LG CHEMICAL)
A	none	FR2858859 A (THOMSON LICENSING)

**Categories:**

X	Document indicating lack of novelty or inventive step	A	Document indicating technological background and/or state of the art.
Y	Document indicating lack of inventive step if combined with one or more other documents of same category.	P	Document published on or after the declared priority date but before the filing date of this invention.
&	Member of the same patent family	E	Patent document published on or after, but with priority date earlier than, the filing date of this application.

**Field of Search:**

Search of GB, EP, WO & US patent documents classified in the following areas of the UKC<sup>X</sup> :

--

Worldwide search of patent documents classified in the following areas of the IPC

G02B; G02F; G09F; H01L; H05B

The following online and other databases have been used in the preparation of this search report

--

**International Classification:**

Subclass	Subgroup	Valid From
H01L	0051/52	01/01/2006
H01L	0027/32	01/01/2006
H05B	0033/22	01/01/2006