

(19) **DANMARK**



Patent- og
Varemærkestyrelsen

(10) **DK/EP 1774799 T3**

(12) **Oversættelse af
europæisk patentskrift**

-
- (51) Int.Cl.: **H 04 W 24/00 (2009.01)** *H 04 W 8/00 (2009.01)* *H 04 W 24/02 (2009.01)*
H 04 W 36/00 (2009.01) *H 04 W 48/12 (2009.01)* *H 04 W 52/02 (2009.01)*
H 04 W 56/00 (2009.01) *H 04 W 84/12 (2009.01)* *H 04 W 92/20 (2009.01)*
- (45) Oversættelsen bekendtgjort den: **2015-07-06**
- (80) Dato for Den Europæiske Patentmyndigheds bekendtgørelse om meddelelse af patentet: **2015-04-08**
- (86) Europæisk ansøgning nr.: **05762531.1**
- (86) Europæisk indleveringsdag: **2005-06-29**
- (87) Den europæiske ansøgnings publiceringsdag: **2007-04-18**
- (86) International ansøgning nr.: **US2005023145**
- (87) Internationalt publikationsnr.: **WO2006017024**
- (30) Prioritet: **2004-07-12 US 587159 P**
- (84) Designerede stater: **AT BE BG CH CY CZ DE DK EE ES FI FR GB GR HU IE IS IT LI LT LU MC NL PL PT RO SE SI SK TR**
- (73) Patenthaver: **InterDigital Technology Corporation, 200 Bellevue Parkway , Suite 300, Wilmington, DE 19809, USA**
- (72) Opfinder: **MARINIER, Paul, 1805 Stravinski, Brossard, Québec J4X 2J7, Canada**
ROY, Vincent, 6254 De La Roche, Montreal, Québec H2S 2E1, Canada
CAVE, Christopher, 63 Place Chambord, Candiac, Québec J5R 4W7, Canada
LA SITA, Frank, 75 Saddle Rock Road, East Setauket, New York 11733, USA
CUFFARO, Angelo, 3837 Place du Brigadier, Laval, Québec H7E 5M7, Canada
TOUAG, Athmane, 752 Olivar-Asselin, Chomedey, Laval, Québec H7V 1V3, Canada
RUDOLF, Marian, 1843 Rue Baile, Montreal, Québec H3H 1P5, Canada
- (74) Fuldmægtig i Danmark: **Awapatent A/S, Rigensgade 11, 1316 København K, Danmark**
- (54) Benævnelse: **Naboscanning i trådløse lokale netværk**
- (56) Fremdragne publikationer:
EP-A2- 0 886 453
WO-A-01/20940
WO-A-2004/054283
US-A- 5 923 702
US-A- 5 970 414
US-A1- 2003 095 516
US-A1- 2003 145 092
US-A1- 2004 100 957
US-A1- 2004 120 292
US-B1- 6 728 540
MOULY M ET AL: "THE PSEUDO-SYNCHRONISATION, A COSTLESS FEATURE TO OBTAIN THE GAINS OF A

Fortsættes ...

SYNCHRONISED CELLULAR NETWORK" November 1991 (1991-11), MRC MOBILE RADIO CONFERENCE, XX, XX, PAGE(S) 51-55 , XP000391318 * the whole document *

DESCRIPTION

FIELD OF INVENTION

[0001] The present invention generally relates to wireless local area networks (WLANs), and more particularly, to methods for scanning for neighboring access points (APs).

BACKGROUND

[0002] WLANs have become more popular because of their convenience and flexibility. As new applications for such networks are developed, their popularity is expected to significantly increase. One of the promising areas is the use of Voice over Internet Protocol (VoIP) and an increasing demand for support of seamless service continuity (i.e., handover) in contiguous WLAN deployment areas when the user is mobile.

[0003] In the IEEE 802.11 standards, the stations (STAs) can use two different modes to identify APs: active scanning mode and passive scanning mode. Whether a STA uses active or passive scanning mode is usually determined by configurable settings; in practice both modes are used. In the active scanning mode, the STA chooses a frequency channel and transmits a Probe Request frame, then waits for a certain amount of time to receive a reply in the form of a Probe Response frame. The Probe Response frame is typically sent by the AP when the basic service set (BSS) operates in infrastructure mode. In case the STA does not receive a Probe Response frame after a certain amount of time, it tunes to a new frequency and repeats the process.

[0004] In passive scanning mode, the STA tries to find out about the presence of a BSS on a particular frequency channel by tuning to the frequency and listening for a certain amount of time in order to capture the beacon frames broadcast in regular time intervals by the AP. In case the STA does not receive a beacon frame after a certain amount of time, it tunes to a new frequency and repeats the process.

[0005] When using passive scanning mode, a STA may know on which frequency channels it is likely to find candidate APs, but it does not know exactly when a beacon frame will be sent by a neighboring AP. Typically, beacon frames are sent in predetermined fixed time intervals, e.g., every 100ms. In the worst case, a STA tunes to the target frequency and must wait for at least 100ms until a beacon frame occurs. In the case where a STA has only one receiver, its ongoing service on the old frequency is interrupted while the STA performs passive scanning on the target frequency.

[0006] Executing an efficient handover in a WLAN implies several requirements, such as: identification and measurements of suitable candidate APs for handover, establishment of a STA's authentication and security context in the target AP, re-association with the target AP, and transferring the data link to the target AP.

[0007] WLANs have traditionally not been developed with the goal in mind to provide full seamless mobility support. One of the problems with the current WLAN systems is that the identification and measurement of suitable candidate APs by the STA is a lengthy process, and could last for several hundred milliseconds. Moreover, STA behavior is not well-specified and the duration of the measurement process can vary largely with different implementations chosen by the manufacturers.

[0008] In order to avoid noticeable service interruption by the user, for example during a VoIP call, the handover process needs to be executed quickly (the service interruption time should typically not exceed several tens to a few hundred milliseconds). In addition, the process of STA measuring and identifying neighbor candidate APs should not impact the performance of the ongoing service in any noticeable manner.

[0009] Therefore, there is a need to improve the efficiency of the passive scanning mode to enable use of the passive scanning mode while guaranteeing service continuity and seamless handover, especially for VoIP. WO-2004/054283-A describes a handoff method in a wireless local area network where a plurality of access points are provided with a nearest-neighbor table including records identifying a nearest neighbor access point and its channel of operation. The table is transmitted to associated stations, which perform a prioritized search to locate at least one candidate access point to form a new association with in the handoff.

[0010] EP-886453-A2 describes a mobile station method for identifying base stations in a cellular network. Frame timing difference data for neighbour base stations are transmitted from the serving base station. Reception times for the neighbour base stations are determined in the mobile station based on the frame timing differences to identify neighbour base stations.

[0011] US-6728540-B1 describes a mobile handover method including transmitting information regarding potential handover candidates to the mobile in its current cell. The candidates are determined based on stored adjacency information and are restricted to cells contiguous with the current cell. The information includes frequency and time slot information associated with a beacon, determined to be observable by the mobile.

SUMMARY

[0012] The scope of the invention is defined by the appended independent claims. The present invention includes methods, signaling mechanisms, and timing information regarding transmission intervals and schedules of neighbor candidate APs. The AP sends timing information about the neighbor candidate APs to the STA, then the STA uses the timing information to schedule its tuning to the target frequency and execute identification and measurement of the target AP in a minimum amount of time.

[0013] Timing information on neighbor candidate APs can be sent to STAs using broadcast/multicast-type frames (for example included in a beacon frame) or unicast type Medium Access Control (MAC) frames. Furthermore, information elements (IE) containing timing information can be sent in MAC management frames or can be piggybacked onto MAC control or data frames.

[0014] A method for neighbor scanning in a WLAN having a STA, a first AP to which the STA is associated, and a second AP begins by generating timing information regarding a beacon signal sent by the second AP. The timing information is reported from the first AP to the STA. The STA schedules a time, based on the timing information, to listen for the beacon signal transmitted by the second AP.

[0015] A system for neighbor scanning in a WLAN includes a STA, a first AP to which the STA is associated, and a second AP. The STA includes a first timing information device, a scheduling device configured to receive timing information from the first timing information device, and a receiver for receiving communication signals and capable of being controlled by the scheduling device. The first AP includes a second timing information device, which sends timing information to the first timing information device in the STA. The second AP includes a beacon transmission device for transmitting a beacon signal, wherein the timing information relates to the beacon signal.

BRIEF DESCRIPTION OF THE DRAWINGS

[0016] A more detailed understanding of the invention may be had from the following description of a preferred embodiment, given by way of example, and to be understood in conjunction with the accompanying drawings, wherein:

Figure 1 is a flow diagram of a method for communicating timing information between a STA, an AP associated to the STA, and a candidate AP;

Figure 2 is a diagram illustrating the timing for scanning one candidate AP;

Figure 3 is a diagram illustrating the timing for scanning N channels; and

Figure 4 is a diagram of a system for communicating timing information between a STA, an AP to which the STA is associated, and a candidate AP.

DETAILED DESCRIPTION OF THE PREFERRED EMBODIMENTS

[0017] Hereafter, the term "station" (STA) includes, but is not limited to, a wireless transmit/receive unit, a user equipment, a mobile station, a fixed or mobile subscriber unit, a pager, or any other type of device capable of operating in a wireless environment. When referred to hereafter, the term "access point" (AP) includes, but is not limited to, a base station, a Node B, a site controller, or any other type of interfacing device in a wireless environment.

[0018] The present invention includes methods where timing information regarding transmission intervals of neighbor candidate APs, typically beacon frame transmit times, are sent to a STA to improve the efficiency of the passive scanning mode.

[0019] The AP sends timing information about the neighbor candidate APs to the STA. The STA then can use the timing information to schedule its tuning to the target frequency and execute identification and measurement of the target AP in a minimum amount of time.

[0020] Figure 1 is a flow diagram of a method 100 for communicating timing information between a STA 102, an AP (AP1) 104 to which the STA 102 is associated, and a candidate AP (AP2) 106. As optional first steps, the STA 102 requests timing information for the candidate AP2 106 from AP1 104 (step 110), which then requests timing information from AP2 106 (step 112). AP2 106 reports its timing information to AP1 (step 114). This step is required only if AP1 has not already obtained AP2's timing information beforehand; there are additional means for AP1 to obtain the timing information (discussed below). AP1 reports the timing information for AP2 to the STA 102 (step 116). The STA 102 then schedules time to tune to AP2's frequency to hear AP2's beacon (step 118).

[0021] Timing information of neighbor candidate APs can include, for example: beacon intervals (the periodicity of occurrence of beacon frames), a targeted beacon frame transmit time, or contention-free and contention-based periods. Timing information about a neighbor candidate AP can be communicated to the STA in form of an absolute time reference (e.g., a time stamp such as, "neighbor beacon frame will occur at time xyz"), or a relative time difference to a known reference (such as indicating the number of time units difference from the frame where the timing information was sent from AP1 to the STA or from AP1's previous or current beacon frame).

[0022] Because the timing of the transmission of the next beacon frame is not known to a precision of more than a few milliseconds due to the requirement for devices to wait for the end of any on-going transmission/reception before transmitting a beacon, the AP signals to the STA an interval of time for the estimated reception (or equivalently, a target time plus an uncertainty margin).

[0023] Timing information supplied to STAs can always be supplemented by uncertainty periods, or by a specified rule allowing the STA to derive the timing information and/or the uncertainty period. Generally, the current AP would not only inform the STA that the beacon frame of the candidate AP will occur N time units earlier than the current AP's beacon frame, but would also inform the STA that, due to uncertainties, the beacon frame of the candidate AP will occur within M time units before and L time units after the indicated time or time interval. Another possibility is that the uncertainty period, instead of being specified every time the AP provides timing information, is signaled separately (through the beacon, for example) or is a specified fixed value. Both of these approaches would save signaling bandwidth.

[0024] Timing information on neighbor candidate APs can be sent to STAs using solicited and/or unsolicited broadcast/multicast-type frames (for example, included in a beacon frame), or solicited and/or unsolicited unicast-type MAC frames (for example, in Association Response frames, Reassociation Response frames, or Probe Response frames). Information elements (IEs) containing timing information can be sent in (or as part of) MAC management frames or can be piggybacked onto MAC control or data frames. Communicating timing information to STAs can also include using inter-layer service primitives (such as MAC↔physical layer (PHY)↔STA management entity (SME)) to initiate, confirm, and report on actions, including sending MAC signaling frames, measurement actions, etc.

[0025] The timing information of neighbor candidate APs can be generated in a particular AP by several methods, including: the AP uses network side signaling to retrieve timing information of neighboring APs, the AP uses its own measurements of neighbor APs, the AP uses reports from STA measurements, or the AP uses a generic timing device on the network.

[0026] In network side signaling, the APs exchange information about the transmission time of their beacons through the distribution system connecting the APs together. There are several possible implementations for network side signaling, such as: an AP broadcasts information about the timing of its beacon transmissions to all APs over the distribution system, or an AP requests beacon timing information from another AP which responds through the distribution system. Alternatively, the AP can query a network timing database, such as advantageously realized as part of a central remote or local network management entity to obtain current timing information about its neighboring APs.

[0027] When the AP uses its own measurements of neighbor APs, the measuring AP listens to the beacons of other APs and measures the transmission time of the beacons. Based on the beacon transmission interval, the measuring AP can infer approximate future transmission times. This method is useful when neighboring APs use the same frequency channel as the measuring AP. Otherwise, this method would require the measuring AP to tune to other frequency channels from time to time so that it can listen to the beacons, which is a less attractive solution.

[0028] For the AP to use reports from STA measurements, STAs report to the coordinating AP the time(s) at which they heard a beacon from neighboring AP(s) along with beacon transmission intervals, the identity of the neighboring APs, and a timestamp of the neighboring AP. The coordinating AP can use this combination of absolute and relative time references to derive the timing information. The coordinating AP stores this information in memory and infers approximate future transmission times of the beacon for these APs.

[0029] When a STA enters a BSS, it can set a flag in the Association Request frame, in the Reassociation Request frame, or in the Probe Request frame. The flag is used to indicate that the STA wants to receive a neighbor report element in the corresponding Association Response frame, Reassociation Response frame, or Probe Response frame. The flag can be implemented in various ways, for example as a simple bit flag or as an IE containing multiple values indicating the type of information the STA desires to retrieve from the AP. The neighbor report element can include a timing synchronization function (TSF) information field, which includes a TSF offset value and a beacon interval value for the neighbor AP. The TSF offset value is expressed in timing units (TUs), which are for example and without loss of generality one microsecond in length, and is the timing offset between the coordinating AP and the neighbor AP expressed in TUs relative to the coordinating AP. The beacon interval value can in one advantageous embodiment and without loss of generality be expressed as a target beacon transmission time (TBTT), which has a typical default value of 100ms.

[0030] Timing information regarding neighbor candidate APs can be stored, accessed, or configured in an AP management information base (MIB). The MIB may be either a MAC layer MIB or a PHY layer MIB.

[0031] Two scenarios are shown in Figures 2 and 3. In Figure 2, when the STA knows the approximate time of arrival of the beacon frame for the neighbor candidate AP, the scanning time during which a STA needs to dwell on a given frequency to hear a particular AP is typically around several milliseconds if the timing information is known, down from one full beacon interval (typically 100 ms), if the timing information is not known.

[0032] In Figure 3, the gain of the proposed method when scanning several APs on different frequencies is illustrated. Typically, when using timing information, the STA can establish a schedule based on the occurrence of the beacon frames and measure all of them in a single or few number of beacon intervals, whereas it would require several beacon intervals if timing information was not used. The "uncertainty interval" shown in Figure 3 refers to the uncertainty regarding the exact time of transmission of the beacon due to the need to defer to other transmissions.

[0033] The methods described above are applicable to IEEE 802.11-based WLANs, and in particular to WLANs based on: 802.11r (Fast BSS Transition), 802.11s (Extended Service Set (ESS) Mesh), 802.11k Radio Resource Measurement, and 802.11n (High-Throughput WLAN). The methods are also applicable to other wireless network types.

[0034] Figure 4 is a diagram of a system 400 for communicating timing information between a STA 402, an AP (AP1) 404 to which the STA 402 is associated, and a candidate AP (AP2) 406. The system 400 can be used when timing information is passed from AP2 to AP1 via the distribution network. The STA 402 includes a timing information device 410, a scheduling device 412, a receiver 414, and an antenna 416. AP1404 includes a timing information device 420. AP2 includes a timing information device 430, a beacon transmission device 432, and an antenna 434.

[0035] The system 400 operates as follows. STA 402 requests timing information about AP2 406 by sending a request from timing information device 410 to the timing information device 420 at AP1404. AP1 404 receives the timing information regarding AP2 406 through timing information device 420 and timing information device 430, respectively. As described above in connection with Figure 1, AP1 404 can receive the timing information regarding AP2 406 in a variety of ways.

[0036] In AP2 406, the beacon transmission device 432 transmits its beacon via antenna 434 and communicates the timing information for transmitting the beacon to the timing information device 430. The timing information is sent from the timing information device 430 to the timing information device 420 in AP1 404. AP1 404 sends the timing information for AP2 406 from the timing information device 420 to the timing information device 410 in the STA 402.

[0037] Once the STA 402 receives the timing information for AP2 406, the timing information is passed from the timing information device 410 to the scheduling device 412. The scheduling device 412 determines when the STA 402 will adjust its receiver 414 to scan and receive the beacon transmission from AP2 406.

REFERENCES CITED IN THE DESCRIPTION

This list of references cited by the applicant is for the reader's convenience only. It does not form part of the European patent document. Even though great care has been taken in compiling the references, errors or omissions cannot be excluded and the EPO disclaims all liability in this regard.

Patent documents cited in the description

- [WO2004054283A \[0009\]](#)
- [EP086453A2 \[0010\]](#)
- [US6728540E1 \[0011\]](#)

P A T E N T K R A V

1. Fremgangsmåde til naboscanning i et trådløst lokalt netværk, der har en station, et første adgangspunkt, AP, til hvilken stationen er tilknyttet, og et andet AP, hvor fremgangsmåden omfatter:
 - 5 at modtage (110) en tidspunktsinformationsanmodning fra stationen ved det første AP;
 - at modtage (114) tidspunktsinformation, som vedrører et pejlingssignal, der er sendt af det andet AP, hvor
 - 10 tidspunktsinformationen indbefatter en tidsforskel i forhold til en kendt referencetid for transmission af et pejlingssignal fra den første AP, og
 - tidsforskellen er en forskydning i tidsenheder;
 - at rapportere (116) tidspunktsinformationen fra det første AP til stationen for, ved stationen, at muliggøre planlægning (118) af et tidspunkt, hvor stationen skal lytte efter pejlingssignalet, der er sendt af det andet AP, hvilken planlægning baseres på
 - 15 tidspunktsinformationen.
2. Fremgangsmåde ifølge krav 1, hvor modtagelsen (114) af tidspunktsinformationen indbefatter at modtage tidspunktsinformationen fra det andet AP gennem netværkssidesignalering.
3. Fremgangsmåde ifølge krav 1, hvor rapporteringen (116) indbefatter at sende tidspunktsinformationen i hvilken som helst af: en pejlingsdatablok, en sonderingsresponsdatablok, en associationsresponsdatablok, en reassociationsresponsdatablok, eller et informationselement i en medieadgangsstyrings-, MAC-, datablok.
- 20 4. Fremgangsmåde ifølge krav 3, hvor MAC-datablokken er af en management-undertype.
5. Fremgangsmåde ifølge krav 1, hvor anmodningen er del af en hvilken som helst af: en sonderingsanmodning, en associationsanmodning eller en reassociationsanmodning.
6. Fremgangsmåde ifølge krav 1, hvor fremgangsmåden yderligere omfatter at anmode om pejlingsmålinger fra stationer, der er tilknyttet det første AP, hvor pejlingsmålingerne indbefatter tidspunktsinformation.
- 30 7. Station, der omfatter det følgende til at opnå naboscanning i et trådløst lokalt netværk:
 - en tidspunktsinformationsindretning (410), som er indrettet til:
 - at sende en tidspunktsinformationsanmodning fra stationen til et første adgangspunkt, AP; og
 - 35 at modtage en tidspunktsinformationsrapport fra det første AP, hvor tidspunktsinformationsrapporten indbefatter tidspunktsinformation for et pejlingssignal, der er sendt af det andet AP, hvor tidspunktsinformationen indbefatter en tidsforskel i forhold til en kendt referencetid for transmission af pejlingssignalet fra det første AP,
 - 40 og tidsforskellen er en forskydning i tidsenheder;

- en planlægningsindretning (412), der er i forbindelse med tidspunktsinformationsindretningen, hvilken planlægningsindretning er indrettet til at planlægge et tidspunkt, hvor stationen skal lytte efter pejlingssignalet, der er sendt af det andet AP, hvor planlægningen er baseret på tidspunktsinformationsrapporten.
- 5 8. Station ifølge krav 7, hvor tidspunktsinformationsindretningen (410) er indrettet til at modtage tidspunktsinformationsrapporten i et informationselement i en medieadgangsstyringsdatablok.
9. Adgangspunkt, AP, der omfatter det følgende for at opnå naboscanning i et trådløst lokalt netværk:
- 10 en sender, der er indrettet til at sende signaler;
en modtager, der er indrettet til at modtage signaler; og
en tidspunktsinformationsindretning (430), der er indrettet til:
at modtage en tidspunktsinformationsanmodning fra en station, som er tilknyttet til AP'et;
- 15 at modtage tidspunktsinformation for et pejlingssignal, der er sendt af det andet AP, hvor tidspunktsinformationen indbefatter en tidsforskel i forhold til en kendt referencetid for transmission af et pejlingssignal fra AP'et, og hvor tidsforskellen er en forskydning i tidsenheder; og
at rapportere tidspunktsinformationen til stationen.
- 20 10. AP ifølge krav 9, hvor tidspunktsinformationen rapporteres til stationen i en hvilken som helst af: en pejlingsdatablok, en sonderingsresponsdatablok, en associationsresponsdatablok, en reassociationsresponsdatablok, eller et informationselement i en medieadgangsstyrings-, MAC-, datablok.
11. AP ifølge krav 10, hvor MAC-datablokken er af en management-undertype.
- 25 12. AP ifølge krav 9, hvor tidspunktsinformationsindretningen (430) er yderligere indrettet til:
at modtage tidspunktsinformation; og
at sende tidspunktsinformationen som respons på anmodningen.
13. AP ifølge krav 9, hvor tidspunktsinformationsanmodningen er del af en hvilken som helst af: en sonderingsanmodning, en associationsanmodning eller en reassociationsanmodning.
- 30 14. AP ifølge krav 9, hvor tidspunktsinformationen modtages fra det andet AP gennem netværkssidesignalering.
15. AP ifølge krav 9, hvor tidspunktsinformationsindretningen (430) er yderligere indrettet til at anmode om pejlingsmålinger fra andre stationer, der er tilknyttet til AP'et, hvor pejlingsmålingerne indbefatter tidspunktsinformation.
- 35

DRAWINGS

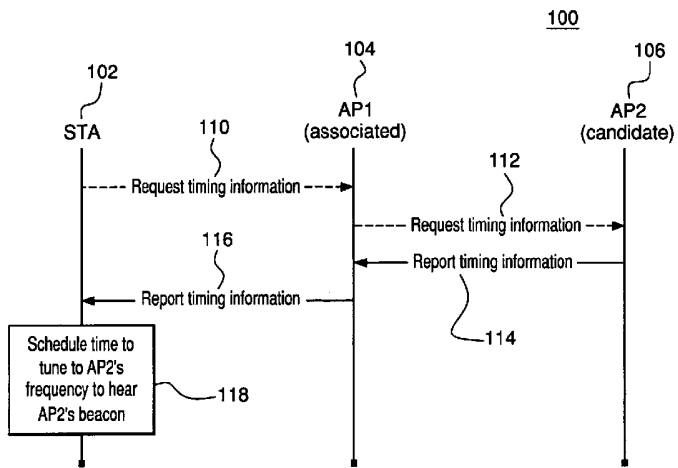

FIG. 1

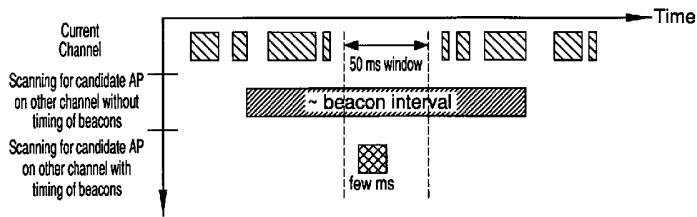

FIG. 2

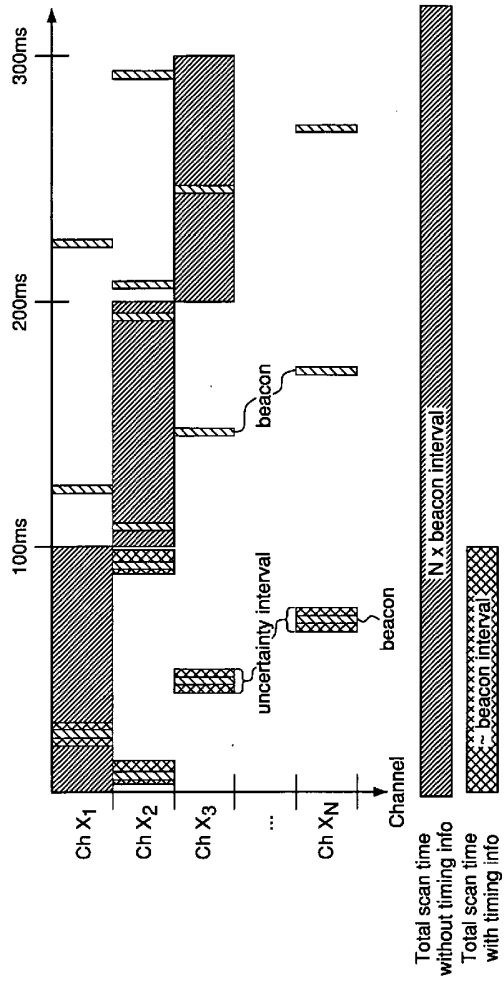

FIG. 3

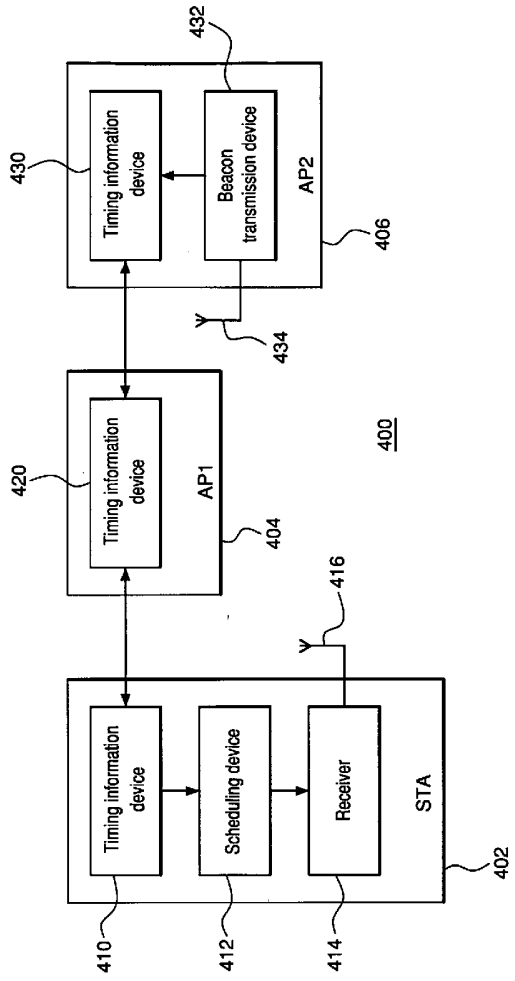

FIG. 4