

(No Model.)

2 Sheets—Sheet 1.

C. F. LITTLEJOHN. SEWING MACHINE.

No. 521,377.

Patented June 12, 1894.

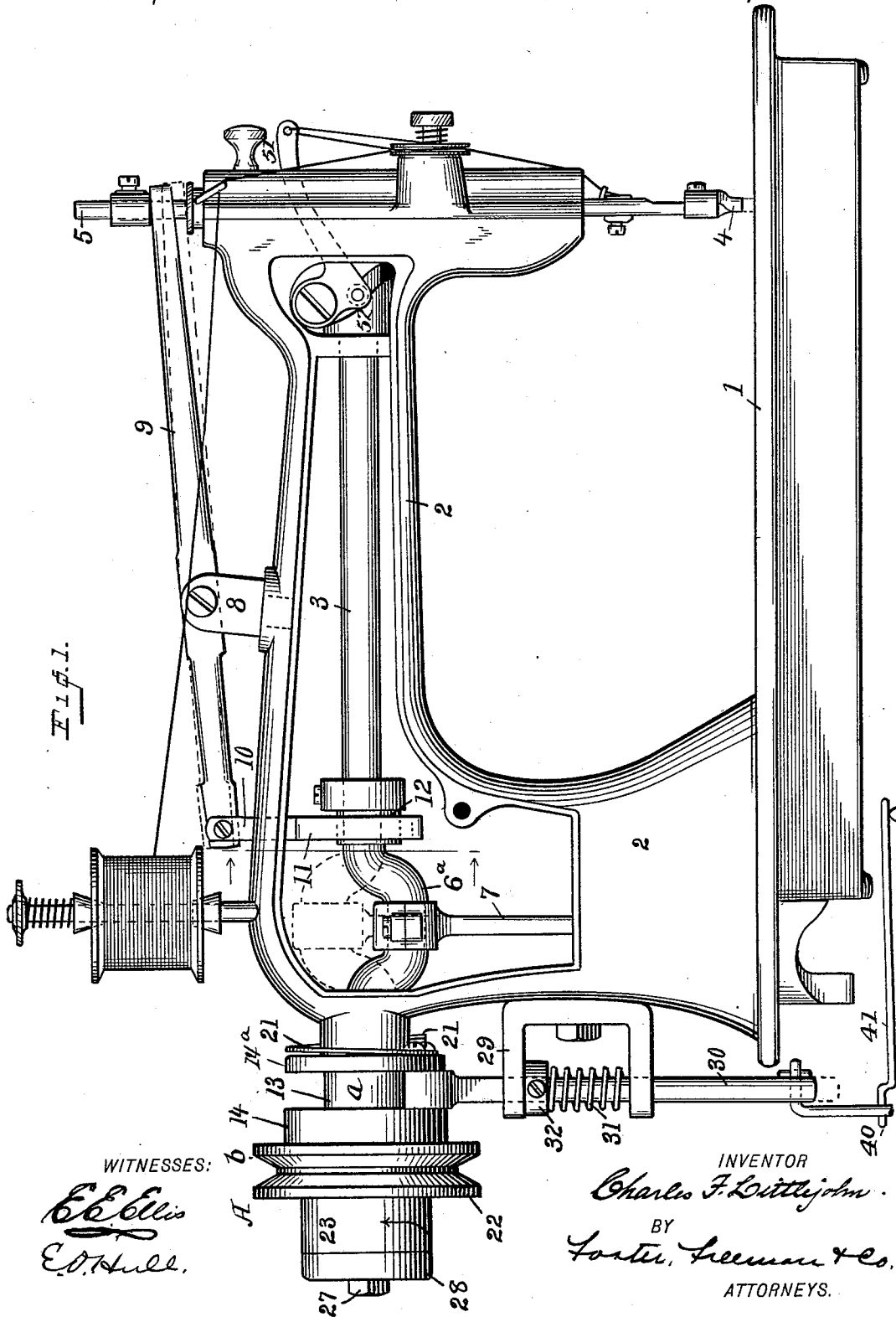

E. L. L.

WITNESSES:

E. L. L.
E. D. Hull.

INVENTOR

Charles F. Littlejohn.

BY

Forster, Freeman & Co.

ATTORNEYS.

C. F. LITTLEJOHN.
SEWING MACHINE.

No. 521,377.

Patented June 12, 1894.

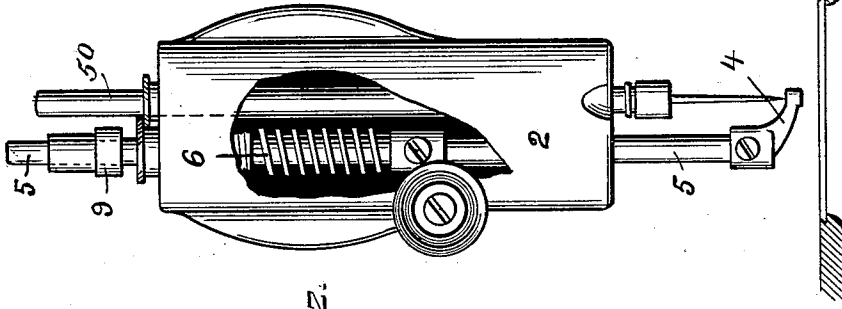

Fig. 2.

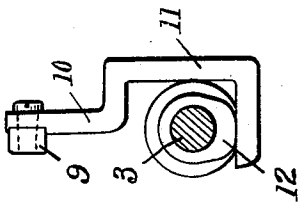

Fig. 4.

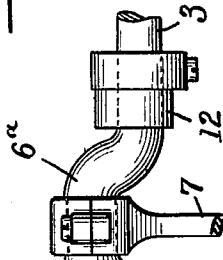

Fig. 5.

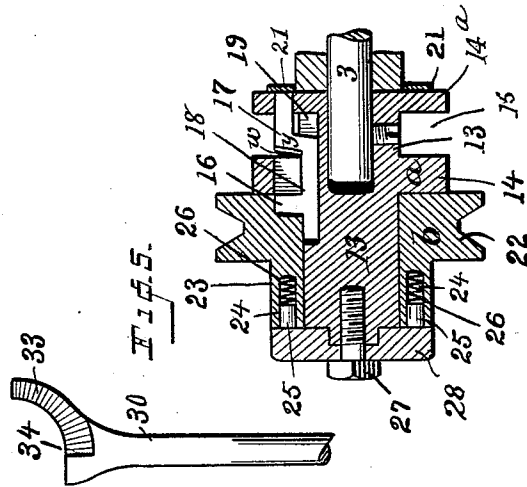

Fig. 6.

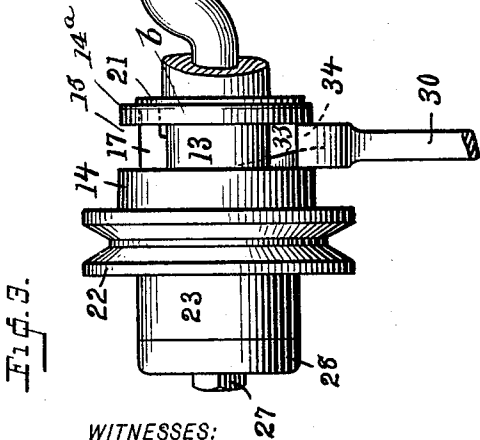

Fig. 3.

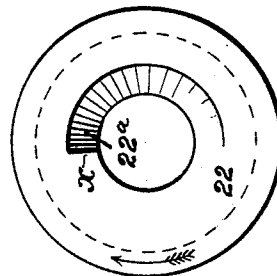

Fig. 7.

WITNESSES:

E. E. Ellis
E. O. Hull,

Charles F. Littlejohn
INVENTOR

BY
Forster, Freeman & Co
ATTORNEYS.

UNITED STATES PATENT OFFICE.

CHARLES F. LITTLEJOHN, OF BRIDGEPORT, CONNECTICUT.

SEWING-MACHINE.

SPECIFICATION forming part of Letters Patent No. 521,377, dated June 12, 1894.

Application filed March 2, 1893. Serial No. 464,440. (No model.)

To all whom it may concern:

Be it known that I, CHARLES F. LITTLEJOHN, a citizen of the United States, residing at Bridgeport, in the county of Fairfield and State of Connecticut, have invented a new and useful Improvement in Sewing-Machines, of which the following is a specification.

My invention relates to that class of sewing machines by which the "flossing" or ornamental stitching of fabrics of various kinds is effected, for instance, on corsets, vests, suspenders, &c., and my invention consists in means fully set forth hereinafter whereby the machine may be arrested at any time by the operator with the presser foot in an elevated position, but without any shock or noise, and whereby the sewing operations may be resumed when required, to which end and also for the purpose of securing other advantages, I construct the machine as fully set forth hereinafter and as illustrated in the accompanying drawings, in which—

Figure 1 represents an elevation of a sewing machine having my improvements embodied in connection therewith, the said view being taken from the side opposite that on which the operator sits, and having the covering plate of the inclosing case or shell removed, so as to more clearly indicate the interior disposition of the operating shaft and its several connections. Fig. 2 is an end elevation of the machine with a part of the shell or casing cut out so as to show the usual arrangement of spring which surrounds the presser foot rod and against which said rod works whenever the presser foot is elevated. Fig. 3 is an enlarged detail view representing a portion of the main operating shaft, together with the clutch and driving pulley in elevation. Fig. 4 is a view in detail representing the main shaft in section, and the cam and yoke, which co-operate with the lifting devices, in elevation. Fig. 5 is a sectional detail taken longitudinally through the clutch and stop devices, to more clearly indicate the arrangement and operation of the devices for effecting the engagement and release of the parts during operation. Fig. 6 is a view in detail to more clearly indicate the construction of the upper end of the rod which automatically effects engagement and disengagement of the clutch and stop mechanisms. Fig.

7 is an inner face view of the driving pulley, showing the construction by which the same is caused to be engaged by the clutch devices.

My improvement may be embodied in machines of different characters and I have shown the same in connection with an ordinary form of machine in which there is a base or bed, 1, inclosing the usual shuttle mechanism not shown, an overhanging arm, 2, a needle bar 50, and a presser foot bar 5, supporting a presser foot 4, with a spring 6, which tends to throw down the presser foot bar. In the construction shown, there is a main driving shaft, 3, which is supported in bearings in the overhanging arm and is provided with a crank 6^a connected by a rod 7 with the shuttle mechanism. There is also a thread controlling lever, 51, operated by a cam, 52, upon the shaft 3. In this character of machine, where ornamental stitching is produced, it is of course necessary that the operator shall be enabled to stop the machine at a moment when the presser foot is off of the cloth, so that the latter may be moved prior to starting the machine again; and it is extremely desirable to have these operations under absolute control, free from any uncertainty, and it is also extremely desirable to stop and start the machine without any jerks, abrupt movements, or noise. To this end, and further to insure simplicity of construction and economy in manufacture, as well as other advantages, I combine with the parts already described or similar parts in other machines of different constructions, means for lifting the presser foot at each revolution of the shaft, and means for arresting the shaft in the position which it occupies when the presser foot is elevated, together with means for stopping and starting the shaft at any moment as desired by the operator without shock.

The elevation of the presser foot at each operation is effected through the medium of connections between the shaft 3 and the presser foot bar 5, as for instance, a lever 9, pivoted to a bracket, 8, at the top of the arm 2, connected at its forward end with the bar 5, and at its rear end with a frame, 10, having a step or foot, 11, which extends under a cam 12 upon the shaft 3, which cam is so arranged as at each revolution to bear upon the said

foot, depress the frame and elevate the front end of the arm 9 and the bar 5.

The cam 52, or other device for operating the take up 51, is so arranged as to effect the requisite draft upon the thread at the proper moments in time with the movements of the other parts.

In order that when the machine is stopped by the operator it shall be arrested with the presser foot 4 in an elevated position, I make use of a clutch device A, which is arranged upon the main shaft 3, so that the clutch device, the crank, the means for operating the presser foot bar and for operating the needle bar, and the thread controller are all carried by the shaft 3 in line with each other upon the overhanging arm, access can be had to all of said parts readily, complication and expense of construction are avoided and friction is reduced to a minimum.

As shown, the shaft carries one part *a* of the clutch device, which part is a hub, 13, having an annular groove 15 near one end and two annular flanges, 14, 14^a with the groove 15 between them, said part *a* being clamped firmly to or forming a part of the shaft 3. The other part *b* of the clutch device is the driving wheel 22, having a V-shaped groove to receive the driving belt, operated from any suitable source, the said driving wheel turning upon the hub, 13, and independently of the latter except when the shaft 3 is to be operated.

In order to connect the two parts *a* and *b* of the clutch together and to disconnect them, I make use of any suitable bolt, as for instance, a sliding bolt, 18, having two bits, 16, 17 and an intermediate radial shoulder *y*, the bit 17, extending through an opening in the flange 14^a; a spring, 21 connected to the end of the part *a* bearing on the end of the bolt and tending to force it toward the left, Fig. 5. The bolt 18 slides in a longitudinal slot 19, in the clutch, so that when it is forward, the bit 16 will not engage the shoulder *x* of the part *b*. It will be observed that the said bit 17, is slightly inclined away from the bit 16, this construction forming a space *w*, between the bit and the inner edge of flange 14 into which space the end of the wedge is received when the latter is caused to be elevated. The said bolt is located in a groove 19, formed in the hub portion of the part *a*, of the clutch and is permitted to work back and forth therein in the manner and for the purpose stated. The end of the bolt projecting through the flange 14^a, is that part against which the spring 21, bears. In the face of the driving wheel 22, constituting the part *b* of the clutch is a curved groove 22^a of gradually increasing depth, extending around the central opening of said part *b*, for about one-half the distance and terminating in an abrupt shoulder *x*. When the driving wheel 22 is turned in the direction of the arrow, Fig. 7, and the bolt or slide 18 is in the position shown in Fig. 5, the bolt and the hub, 13 and the shaft

3 are all carried with the driving wheel, and the sewing operations of the machine are effected. When it is necessary to arrest the operations of the machine with the presser foot elevated from the fabric, this may be done by shifting the bolt 18 to the right, so as to carry the bit 16, away from the shoulder *x*. Different appliances may be used for enabling the operator to thus shift the bolt as required, and to shift it so that the machine will cease its operations with the foot in its elevated position. The means shown consists of a movable curved wedge 33, which is carried by a rod 30, and which rod has an abrupt shoulder 34 at the point of intersection thereof with the wedge, the outer or straight face of latter normally lying against the inner face of the flange 14 of part *a*, and best shown in Fig. 3; but when the machine is in operation the rod 30 and the wedge are lowered, as shown in Fig. 3, so that the rotation of the driving wheel and connected parts does not bring the bolt into contact with the wedge. When, however, the machine is to be arrested, the rod 30 is elevated so that at the next revolution of the parts, the sharp edge of the wedge 33 will enter the space *w* between the shoulder *y* of the bolt and the inner edge or face of the flange 14 of part *a*, and as the revolution is continued, the shoulder *y* bearing on the inclined face of the wedge will cause the bolt to be thrown to the right until the bit, 16 is carried away from the shoulder *x*, and the driving wheel or part *b* of the clutch can revolve without carrying with it the hub, 13 and the shaft 3.

It will be evident that it would be impossible, to insure any absolute precision of movement so as to cause the shaft 3 to cease its operations with the presser foot up by merely depending upon disconnecting the bit 16 and the shoulder *x*. I therefore provide a shoulder 34 of the wedge 33 in such position that the bit 17 of the bolt will strike the shoulder 34, when the shaft 3 is in such position that the presser foot 4 is elevated from the fabric, but the parts are so arranged that the bit, 16 will be carried away from the shoulder *x* before the bit 17 strikes the shoulder 34, so that the bolt is not driven with the full power of the driving wheel against the shoulder, and an abrupt movement and a sudden shock are prevented. In order that the part *a*, of the clutch will be carried around with absolute certainty to engage the shoulder or stop 34, as the wedge is moved up to separate the part *b*, from said part *a*, I provide for a frictional contact or bearing between the driver or part *b*, and the parts driven thereby, to wit, the part *a*, and the driving shaft; the construction and operation of such frictional devices being presently explained. Different frictional connections between these parts may be provided as will be evident to any skilled mechanic, thus, in the hub 23 of the driving wheel 22, I make recesses in which are placed springs 26, and pins 25, the ends of which bear upon a disk

or cap 28 on the end of the hub 13 with greater or less pressure accordingly as the cap is carried nearer to or farther from the end of the hub by means of a bolt 27, an angular projection on the hub 13 extending into a recess in the cap and preventing the latter from turning, with respect to the part *b*. It should be remarked that the friction produced by the wedge entering between the bit 17 and side of flange 14, tends in a measure to check the speed of the main-shaft, and sometimes the bit 16, is carried away from shoulder *a*, before the bit 17, is brought against the shoulder 34, of the wedge. It will therefore be evident from the construction described that while the bit 16 is carried away from the shoulder *a* before the bit 17 is brought against the shoulder 34, there still will be sufficient frictional connection between the driving wheel and the hub 13 to cause the latter to revolve and overcome the retarding tendency of the wedge and presser-foot mechanism and thereby bring the bit 17 against the shoulder 34, but without the shock which would otherwise result. Further, the frictional contact between the driving wheel and the driven part of the clutch will prevent the spring 6 from throwing down the presser foot which otherwise might result if the shaft and its hub were entirely disconnected from the driving wheel before the bit 17 was brought against the shoulder 34.

Any suitable means may be employed for raising and lowering the wedge 33 at the will of the operator. As shown the rod 30 slides in a bracket 29 carried by the arm 2 of the machine, and a spring 31 bearing upon the bracket and on the shoulder 32 upon the rod 30 serves to normally elevate the part, while a rod 40 may extend to a treadle 41 or to any other suitable device for enabling the operator, to depress the rod.

When operations are to be renewed, the wedge 33 is lowered when the spring 21 will push out the bolt to the left and its bit 16 will bear on the inclined face of the recess 22^a gradually moving outward until it strikes the shoulder *a*, the friction between the end of the bit and the inclined face causing the parts to be carried to a certain extent with the part *b* of the clutch thereby lessening the shock of the contact between the bit and shoulder.

Having thus fully described my invention, what I claim, and desire to secure by Letters Patent, is—

1. In a sewing machine of the character described, the combination of the main shaft and its driving mechanism, the presser-foot and needle bar, and their operating mechanisms, and connections between the driving mechanism and the main shaft so constructed and arranged relatively to the presser-foot and needle bar mechanisms as to automatically and positively arrest the needle-bar and presser-foot in an elevated position on the

stopping of the machine at any stage in the operation of stitching, as set forth.

2. In a sewing machine, the combination of the presser foot and its bar, the needle-bar, operating shaft and connections, means for elevating said presser-foot and needle-bar at each revolution of the shaft, and a driving pulley and a clutch device between the pulley and shaft comprising independent frictional connections between the driving part of the clutch device and the said shaft, substantially as described.

3. In a sewing machine, the combination of the presser-foot bar, means for lifting the foot at each revolution of the shaft, operating shaft and connections, and a driving pulley and a clutch device between the pulley and shaft, comprising independent frictional connections between the driving part of the clutch device and the said shaft, substantially as described.

4. In a sewing machine, the combination of the main shaft, the presser foot and its bar, a lever and the connection from the shaft for operating said presser foot and the bar to lift the same at each revolution of the shaft, and a clutch device between the driver and the main shaft, consisting of two parts and a bolt, means for disengaging the clutch parts, and independent frictional driving connections between the driving part of said clutch and the main shaft to advance the latter a predetermined distance after the clutch parts have been disconnected, substantially as described.

5. In a sewing machine the combination of the main shaft and means for operating the same, the presser foot and its bar, a lever for operating said presser foot and bar to lift the same at each revolution of the shaft, a yoke operating said lever from the shaft, means on the shaft for operating the yoke, and a clutch device between the driver and the main shaft, consisting of two parts and an intermediate bolt, and means for shifting said bolt to disconnect it from one of the parts and means for elevating the presser foot after the shifting of said bolt, and as the machine stops, substantially as described.

6. In a sewing machine, the combination with the main shaft and means for operating the same, the presser foot and its bar, a lever and connections from the shaft for operating said presser-foot and bar at regular intervals, and a clutch between the main-shaft driver and main shaft consisting of two parts and a bolt, means for shifting the bolt, and a shoulder or bearing arranged to be struck by the bolt as the presser foot reaches its elevated position, substantially as described.

7. The combination of the shaft-driver, presser-foot and connections and means for driving the same, of a clutch device between the driver and shaft having a part *a* carrying a bolt, a part *b* and means for driving the latter, frictional connections between said driver and shaft, and means for shifting the bolt im-

mediately before the presser-foot is elevated, substantially as set forth.

8. The combination of the shaft-driver, presser-foot and means for operating the same to lift it at each revolution, and a clutch between the driver and main shaft consisting of the parts *a*, *b*, and bolt having a shoulder, and a movable wedge having a shoulder 34, and means for shifting the position of the wedge to engage the bolt immediately before the presser-foot reaches its elevated position, substantially as described.

9. In a sewing machine of the character described, the combination of the main shaft and its driving mechanism, the presser foot and its rod, a lever and connections for operating said presser foot and rod to lift the same at each revolution of the main shaft, the needle bar and its operating mechanism, and connections between the driving mechanism and the main shaft so arranged relatively to the presser foot and needle bar mechanisms, as to automatically and positively arrest the needle bar and presser foot in an elevated position, substantially as set forth.

10. In a sewing machine of the character described, the combination with the main shaft and means for operating the same, the presser-foot and its bar, and a lever for operating said foot and bar, connections between said lever and the main shaft for vibrating the same, of the clutch ring, the bolt or slide

18 working therein and formed with the bits 16 and 17, the spring plate attached to the side of said clutch ring and normally pressing the bolt inward, the drive pulley having the inclined groove or recess on its inner side, and the spring-actuated rod 30 having its upper portion beveled or inclined and formed with the "stop" or shoulder, the said rod being normally maintained upward, substantially as described.

11. In a sewing machine of the character described, the combination of the main shaft, presser-foot and bar, and operating lever, connections between said lever and main shaft for vibrating the same, of the clutch and stop mechanism consisting of the hub formed or provided with the clutch ring, the drive pulley, the spring cushion or cap bearing against said drive pulley, and adjustable with respect thereto, the spring bolt working in said hub, and the spring-actuated rod 30 formed at its upper portion with a curved and beveled member and constructed with the stop 34, substantially as described.

In testimony whereof I have signed my name to this specification in the presence of two subscribing witnesses.

CHARLES F. LITTLEJOHN.

Witnesses:

EDWARD E. ELLIS,
ELBERT O. HULL.