

(No Model.)

3 Sheets—Sheet 1.

A. LEE.  
MAGAZINE GUN.

No. 522,605.

Patented July 10, 1894.

Fig. 1.

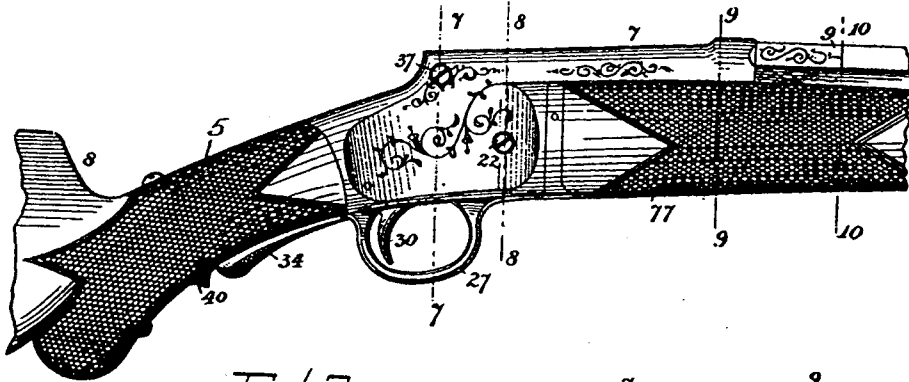

Fig. 2.

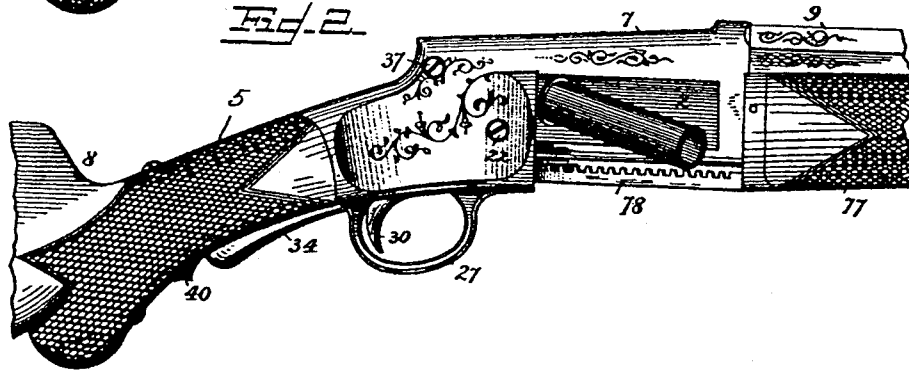
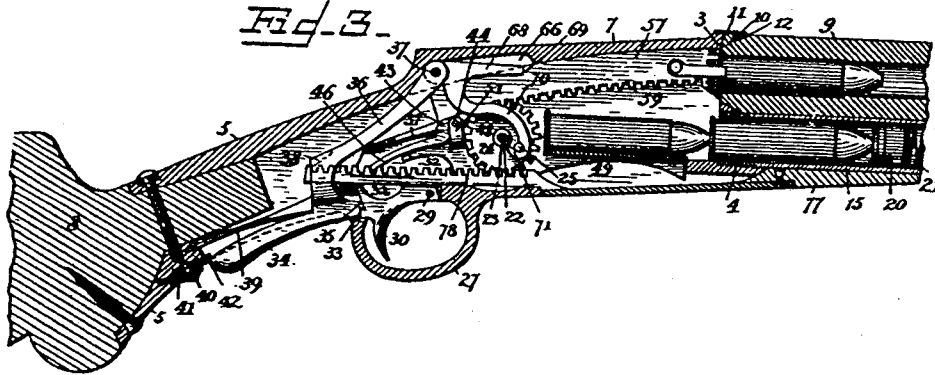

Fig. 3.



Inventor

A. Lee

Witnesses

Chas. H. Curand  
S. B. Wheeler.

By his Attorneys.

Chas. H. Curand & Co.

(No Model.)

3 Sheets—Sheet 2.

A. LEE.  
MAGAZINE GUN.

No. 522,605.

Patented July 10, 1894.

Fig. 4.

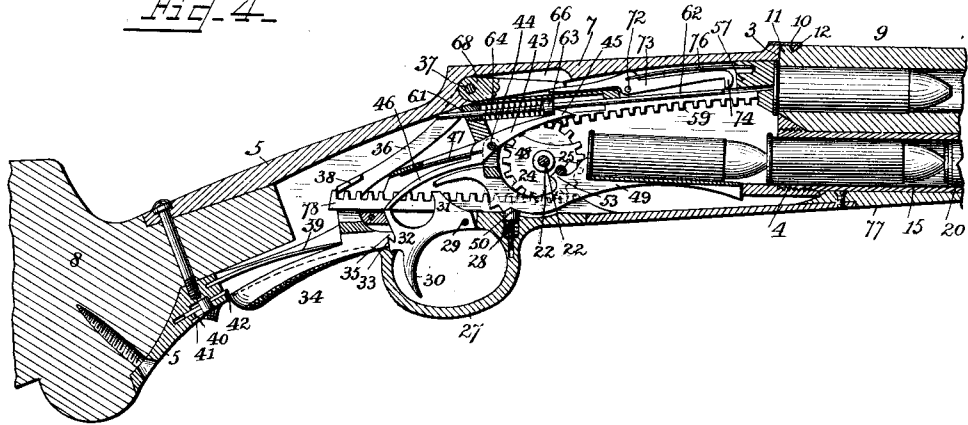

Fig. 5.

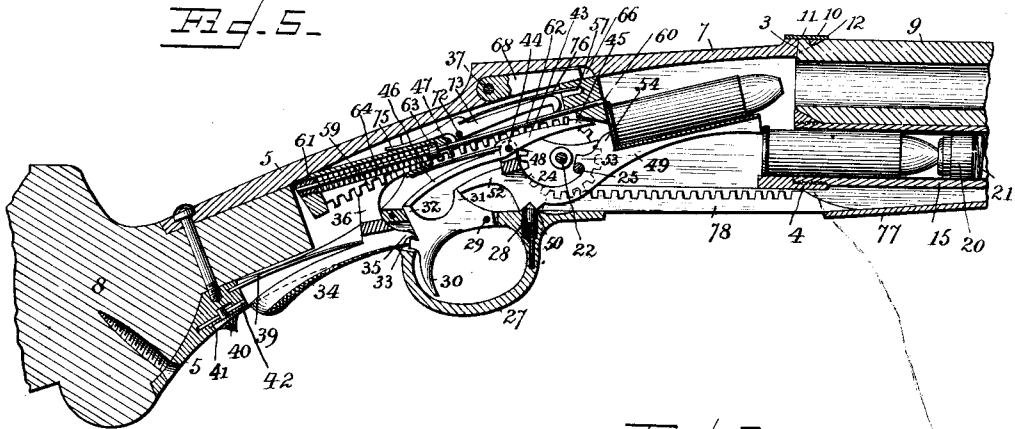
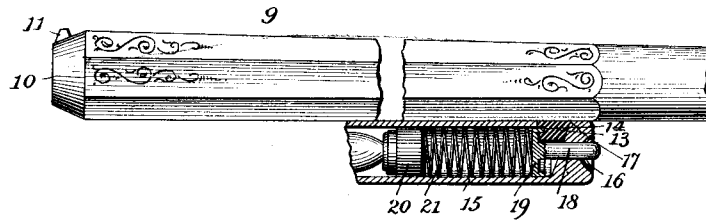

Fig. 6.



Inventor

Witnesses

Chas. H. Ourand  
S. O. Holhaender.

By his Attorneys,

A. Lee

C. Snow & Co.

(No Model.)

3 Sheets—Sheet 3.

A. LEE.  
MAGAZINE GUN.

No. 522,605.

Patented July 10, 1894.

Fig. 7.

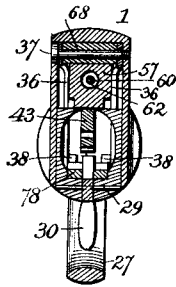

Fig. 8.

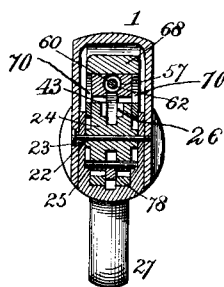

Fig. 9.

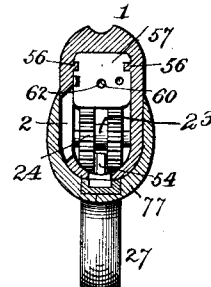

Fig. 10.

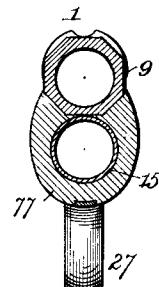

Fig. 11.

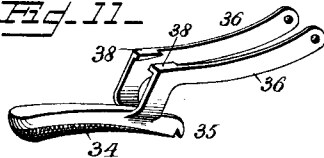

Fig. 12.

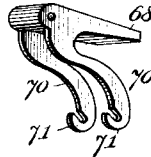

Fig. 13.

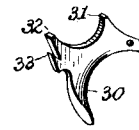

Fig. 14.

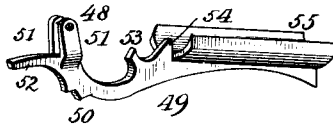

Fig. 15.

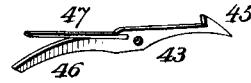

Fig. 16.

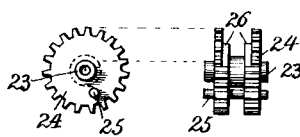

Fig. 17.

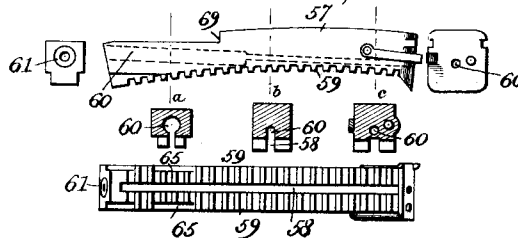

Fig. 18.



Inventor

A. Lee

Witnesses

Chas. H. Ourand  
D. O. Halhauser

By his Attorneys.

C. Snow & Co.

# UNITED STATES PATENT OFFICE.

ALFRED LEE, OF NEW WHATCOM, WASHINGTON.

## MAGAZINE-GUN.

SPECIFICATION forming part of Letters Patent No. 522,605, dated July 10, 1894.

Application filed February 7, 1894. Serial No. 499,400. (No model.)

*To all whom it may concern:*

Be it known that I, ALFRED LEE, a citizen of the United States, residing at New Whatcom, in the county of Whatcom and State of Washington, have invented a new and useful Magazine-Firearm, of which the following is a specification.

My invention relates to magazine fire-arms of that particular class wherein a movable fore-arm is employed for the purpose of elevating from the magazine cartridges and withdrawing for ejection the unexploded shells.

The objects of my invention are to improve the general construction of such arms, and to produce a hammerless arm adapted for rapid action, that consists of few parts of simple construction and assemblage, and which is absolutely safe against accidental or premature discharge.

Other objects and advantages of the invention will appear in the following description, and the novel features thereof will be particularly pointed out in the claims.

Referring to the drawings:—Figure 1 is a side elevation of a portion of an arm embodying my invention. Fig. 2 is a similar view, the arm being in position as when fired and in the act of discharging a shell. Fig. 3 is a longitudinal sectional view at one side of the center, the arm being ready for firing. Fig. 4 is a similar view to Fig. 3, the section being through the center. Fig. 5 is a view similar to Fig. 4, the arm having been fired and in the act of elevating a cartridge from the magazine to the barrel. Fig. 6 is a detail elevation partly in section of a part of the barrel with the magazine attached. Fig. 7 is a cross section on the line 7—7 of Fig. 1. Fig. 8 is a similar view on the line 8—8 of Fig. 1. Fig. 9 is a similar view on the line 9—9 of Fig. 1. Fig. 10 is a similar view on the line 10—10 of Fig. 1. Fig. 11 is a detail in perspective of the safety lever. Fig. 12 is a detail in perspective of the locking lever. Fig. 13 is a detail in perspective of the trigger. Fig. 14 is a detail in perspective of the cartridge carrier. Fig. 15 is a detail in perspective of the sear. Fig. 16 is a detail elevation and projection of the pair of pinions. Fig. 17 is a series of elevations, sections, and plan views of the breech-bolt. Fig. 18 is a detail in perspective of the fore-arm rack bar.

Like numerals of reference indicate like parts in all the figures of the drawings.

The receiver 1 is bored laterally, as is usual, and has one of its side walls and a portion of its bottom wall agreeing therewith removed, forming an opening 2. The opposite side wall and the entire upper side of the receiver are closed, and hence the admission of moisture to the receiver when the arm is in ordinary use and position is avoided. The receiver at its front end is provided at its upper side with a concaved seat 3, and below the same with a threaded socket 4. The rear end of the receiver is extended to form the usual grip-embracing straps 5, and the same are secured to the stock or butt 8 in the usual manner.

The barrel 9 has its rear end provided with a conical or reduced portion 10, the same being adapted to fit snugly yet removably into the concaved seat 3 with which the receiver is provided. This conical portion 10 also has formed upon it a tenon 11 which projects from its upper side, and the same engages with a hook or mortise 12 formed on the front end at the upper side of the receiver. The under side of the barrel is provided with a depending lug 13, the back edge of which has a notch 14 formed therein. Arranged below the barrel is the tubular magazine 15, the same being bored from its rear end to a point near its front end. The rear end of the magazine is externally threaded into the threaded socket 4. The outer end of the magazine is concaved and provided with a perforation 16, and the upper side of the magazine is provided with an opening or slot 17, into which the lug 13, which by reason of the notch 14 is L-shaped, passes. A locking-pin 18 is mounted loosely in the perforation 16 at the front end of the magazine, and is provided at its inner end with a flanged locking-head or disk 19. In advance of the locking-pin a follower 20 is arranged in the magazine, and a coiled magazine spring 21 is interposed between the follower and the locking-head or disk 19, the tendency of the spring being to throw the pin to the front and hence cause the flanged locking-head to engage with the notch 14 of the L-shaped lug 13. By such an arrangement it will be seen that to remove the barrel for any purpose, as for cleaning, repair, or for the substitution of another bar-

rel, it is simply necessary to press the pin 18 to the rear so as to disengage its flanged locking-head or disk with the notch 14 of the L-shaped lug 13, and afterward elevate the front end of the barrel so as to disengage the tenon with the mortise 12 of the receiver. To replace the barrel the operation is simply reversed; the tenon is first engaged with the mortise, the barrel being disposed at an angle to the receiver during such engagement, after which by lowering the front end of the barrel into parallelism with the receiver and upon the same, the lug 13 will pass into the opening 17 of the magazine, and the locking-disk engage with the said lug.

Extending transversely through the receiver is the shaft or pin 22, and located rotatably thereupon is the hub 23, upon which are located the pinions 24, the same being spaced a short distance apart. A transverse pin 25 passes eccentrically through the two pinions and extends slightly beyond their outer faces, and each of said pinions has its inner side segmentally cut away or recessed as at 26.

Secured to the under side of the receiver is the trigger-guard 27, and the same is arranged under the usual trigger-opening of the receiver, and in advance of said opening is provided with a spring-detent 26, whose upper conical end extends into the receiver. Pivoted at 29 within the trigger-opening of the receiver is the trigger 30, and the same is provided in rear of its pivot with the projections 31 and 32 and with the notch 33 in rear of said projections. In rear of the trigger-guard the receiver is provided with an opening or slot in its under side, and arranged therein is the finger-plate 34 of the safety-lever. This finger-plate has formed on its front end a beveled finger 35, and in rear of the same there extends upward and forward from said plate a pair of bell-crank levers 36 which are parallel to each other and have their front ends or extremities perforated and pivoted by a pin 37 within the receiver. At their angles these levers 36 are provided at their inner sides with inwardly disposed beveled locking-lugs 38 spaced a short distance apart. A spring 39 is arranged in the rear end of the receiver and bears at its free end upon the finger-plate of the safety-lever so as to normally depress said rear end and the finger 35 into the notch 33 at the rear end of the trigger and abut against said trigger preventing the latter from being pulled until the finger-plate of the safety-lever has been pressed upward by the pressure of the fingers upon the stock.

For the purpose of preventing children and other irresponsible persons from accidentally pressing the safety-lever upward and for obviating any accident while transporting the gun or handling the same carelessly, I prefer to employ a sliding catch 40, locating the same in a slot or recess 41 in the rear end of the receiver and adapting it to be moved for-

ward so as to engage its catch pin 42 above the rear end of the plate 34. When this is done the finger-plate cannot be elevated so as to unlock the piece, nor is it likely to be accidentally moved by any handling which the arm may receive.

Located in the recesses 26 of the pinions 24 is the front end of a sear 43, which as shown, is pivoted by a transverse pin 44 in rear and above the axes of the pinions. The sear is provided at its front end upon its upper side with a beveled shoulder 45 and in rear of the pivot with the tail or extension 46. The usual sear-spring 47 is engaged under the sear-catch and serves to normally depress the rear or tail portion of the sear and elevate the front end. The rear end of the sear rests upon the projection 32 of the trigger, and hence any elevation of the trigger, as thus engaged with the rear end of the sear, will cause an elevation of the rear end of the sear and a lowering of the front end thereof.

In rear of the pinion there is pivoted at 48 on the pin 44 the carrier 49. The carrier consists of the curved arm, having upon its under side below its pivot an angular indentation 50, which when the carrier is elevated engages with the detent 28 and is temporarily locked in its elevated position. The arm of the carrier is provided with a pair of lugs 51, which engage loosely with the transverse pin 44 at 48, and in rear of the same with an extension or finger 52, whose extremity is beveled and which rests against the projection 31 of the trigger. In front of the lugs 51 the arm of the carrier is curved upward and is provided with a hook or catch 53. Beyond this point the arm is provided with a stop-shoulder 54, and beyond this is provided with the curved carrier-plate 55 which forms the rest for the cartridge. The arm of the carrier, it will be understood, passes between the two pinions, and the hook 53 of the arm lies in the path of that portion of the transverse-pin 25 that passes through the pinions, that is between said pinions and hooks, so that when the pinions revolve the hook of the carrier-arm is engaged by this pin 25 and the arm elevated so as to raise cartridges from the magazine to the breech of the barrel.

The opposite walls of the receiver are, near their upper edges, provided with the horizontal guide-ribs 56, and the same form the ways upon which moves the breech-bolt 57. This breech-bolt 57 has its under side provided with a central slot 58, which extends nearly from end to end of the bolt, and at opposite sides of said slot is provided with teeth 59, thus forming a rack-bar. At its front end the bolt is provided with ordinary extractors, adapted to engage the flange of the shell; and said bolt is furthermore provided with a longitudinal bore 60 throughout its length but which is slightly reduced at its forward half. This bore communicates with the slot 58, and arranged within the slot is the beveled shoulder 45 of the sear, the same being yieldingly

pressed upward into the bore. The rear end of the bore of the breech-bolt is provided with a threaded plug 61, the same having a perforation concentric with that of the bore. Arranged within the bore is the firing-pin 62, the same extending throughout the bore and adapted to pass rearward through the perforation in the threaded plug 61. The firing-pin is provided at an intermediate point with an annular shoulder 63, and in rear of the same there is located a coiled spring 64, the rear end of which bears against the threaded plug. The office of this threaded plug is to permit of the introduction into the bore of the firing-pin and the coiled spring, and retain the latter in position. The tendency of the spring, of course is to throw the firing-pin to the front, its travel being arrested by the abutting of the stop 63 against the annular wall formed within the bore by the contraction of the front portion thereof.

It will be obvious that by a forward movement of the breech-bolt the annular shoulder 63 will engage with the beveled shoulder of the sear and a continued movement of the breech-bolt may take place while the firing-pin will remain stationary until liberated by a withdrawal of the sear through the medium of the trigger and a consequent throwing of the firing-pin against the cartridge.

It will be observed that each of the rack-bars 59 is in engagement with a pinion 24, and that as shown each of said rack-bars is provided near its rear end upon its outer side with a plain or untoothed portion 65.

In line with the pinions and above the breech-bolt the roof or upper side of the receiver is provided with a chamber 66, and pivoted within the chamber by a pin 67 is a locking-lever 68, which extends forwardly and is adapted to drop into the path of a shoulder 69 formed on the upper side of the breech-bolt by a reduction of the latter. This locking-lever is of bell-crank shape, that is to say it is provided with a pair of depending, in the present instance compoundly curved, arms or branches 70 whose lower extremities embrace the outer sides of the pinions and at their inner edges are provided with terminal hooks 71 that lie in the paths of the ends of the transverse trip-pin 25.

The upper side of the breech-bolt is recessed longitudinally, and arranged within the recess and pivoted intermediately by a transverse-pin 72 is a catch 73 whose front end terminates in a depending hook 74, and whose rear end forms a trip-finger 75 that extends beyond the shoulder 69 on the upper side of the breech-bolt and into the path of the free end of the locking-lever 68. When the locking-lever is raised the catch 73 is depressed by the spring 76 so that its front end takes into the path of the firing-pin and prevents the latter from being accidentally thrown forward and causing any premature explosion.

The sliding-plate or fore-arm 77 embraces and slides upon the magazine, and is adapted

when in its rearmost position, to close the opening 2 at the side and bottom of the receiver. The rear end of the fore-arm has attached thereto in any suitable rigid manner a rack-bar 78, whose teeth are formed upon its upper side and which meshes with the teeth of the pinions 24 under which it passes. The rack-bar furthermore passes under the beveled lugs 38 of the bell-crank arms of the safety-lever, and such passage is not impeded when the rack-bar moves to the rear. Any attempt, however, to move the rack-bar to the front is opposed by the lugs 38, in that the latter engage with the rear tooth of the rack-bar and the latter cannot be moved until the safety-lever is elevated so as to remove the lugs from their engagements.

This completes the construction of my improved fire-arm, which it will be seen comprises but few parts and they of simple construction, easy of assemblage, and strong.

The operation will at once be obvious from the foregoing description, but in order to avoid any mistake thereof I will briefly state it as follows:

Presuming that the magazine is filled with cartridges and that a cartridge is in the barrel and the parts are in the position shown in Fig. 4, the piece or arm is gripped in a manner that is usual, the fingers of the right-hand passing under the finger-plate of the locking-lever and hence elevating the same so as to liberate the trigger. The left hand grasps the fore-arm 77, and the piece being brought to the shoulder, the trigger is pressed. The pressure upon the trigger causes the rear or tail end of the sear to raise and withdraws the shoulder of the sear from engagement with the stop or shoulder of the firing-pin, permitting the latter to be thrown by its spring against the cartridge, and by its impact exploding the same. Having fired the piece it is desirable to discharge the exploded shell and elevate a new cartridge to the barrel, which is accomplished as follows: The mechanism for accomplishing this is operated, or set in operation, by a forward movement upon the part of the fore-arm, and the recoil of the piece when discharged will cause the shoulder of the person firing the piece and against which the butt thereof rests, to swing backward slightly, which facilitates or aids an opening of the chamber by a rearward pull of the piece in contradistinction to the operation of the fore-arm by the left-hand of the operator, so that the operator does not have to move his left hand the entire distance necessary to open the piece, but, as will be obvious, as he moves the left hand forward the right hand moving with the shoulder that swings backward to the recoil of the piece, draws the piece with it. This movement of the fore-arm of the piece and the left hand of the operator is insufficient to disconcert the aim of the person firing and may be accomplished in an instant. The movement of the fore-arm causes the rack-bar 78, which en-

gages with the pinions, to rotate the same, and such rotation will necessarily cause the teeth of the pinions to operate in the teeth of the breech-bolt and thus retract the latter. Such retraction is permitted so far as the locking-lever 68 is concerned, in that the ends of the pins 25 serve, through the medium of the bell-crank arms 70 of said locking-lever, to elevate the same, and it is to permit of this elevation previous to the retraction of the breech-bolt that the recesses 65 in the rack-bars of the breech-bolt are provided, whereby, as will be obvious, the pinions can then travel a short distance, namely, enough to elevate the locking-bolt before the teeth of the pinions operate in the teeth of the rack-bars of the breech-bolt. The instant that the locking-lever 68 is raised the catch 73 drops into the path of the firing-pin and prevents any accidental explosion, if, for instance, it should be desired to withdraw an undischarged cartridge. This forward movement of the fore-arm also causes the intermediate portion of the pin 25 to engage with the hook 53 of the arm of the carrier and causes said arm to rise together with the carrier, and thus deliver or hoist the cartridge to a point in rear of the breech of the barrel. The line of the cartridges within the magazine is arrested by abutting against the front end of the arm of the carrier. The cartridge is forced into the breech by the forward movement of the breech-bolt, as is usual. Immediately that the fore-arm is returned to its former or closed position a reverse operation or rotation of the pinion takes place, and the carrier is forced to its lowermost position, where a fresh cartridge is forced upon it from the magazine. The teeth of the pinions engaging with those of the breech-bolt serve to actuate the breech-bolt in a forward direction, and the latter pushes the cartridge snugly into the breech of the barrel, after which the pin 25 engaging with the hooks 71 of the arms 70 of the locking-lever, draws the same down into position so as to lock the bolt against rebound by the explosion and elevates the locking catch 73 out of its operative location with reference to the firing pin, so that all that is necessary to be done to discharge the piece is to repeat the operation first described.

As before stated, the rebound of the piece when discharged of course causes the shoulder of the person firing to swing backward, and thus as before explained, aids in the operating of the parts, so as to expel the exploded shell. The natural movement of the shoulder to regain its former position, together with a short rearward movement of the left hand of the operator, serves to close the fore-arm over the opening in the receiver and accomplish the second portion of the described operation, namely, the elevation of the fresh cartridge to the breech of the barrel and the forcing of the same into the barrel by the breech-bolt.

From the foregoing description in connection with the accompanying drawings, it will

be seen that I have provided a fire-arm that consists of very few parts, the same being durable, readily removed, and positive in their operations, and that by their movements I produce an arm that is rapid in its action and in whose handling the possibility of accidents is reduced to a minimum.

I have shown my invention as adapted for a rifle, but it will be obvious that it may be applied with equal success to a shot-gun.

I do not limit my invention to the precise details of construction herein shown and described, but hold that I may vary the same to any degree and extent within the knowledge of the skilled mechanic.

Having described my invention, what I claim is—

1. In a fire-arm, the combination with a receiver terminating at its front end in a concaved seat, of a magazine secured to the receiver below the seat and extending in front thereof and provided with a slot, a barrel having a rear conical end adapted to fit the seat, a lug or tenon arranged on the end of the barrel, a mortise for engaging said lug formed in the receiver, a lug on the barrel extending into the magazine and provided with a recess, and a reciprocating-pin mounted in the end of the magazine and adapted at its inner end for engaging the recess in the lug of the barrel, substantially as specified.

2. In a fire-arm, the combination with a receiver, terminating at its front end in a conical seat and above the same provided with a mortise, and a magazine arranged in the front end of the receiver below the seat and extending in front of the same, said magazine having a concaved forward end provided with a perforation and upon its upper side provided with a slot, a pin arranged in the perforation and extending into the concavity, a flanged disk or head at the inner end of the pin, a follower-block arranged in the magazine, and a coiled spring interposed between the follower-block and the head or disk, of a barrel having a conical rear end provided with a tenon for engaging the mortise in the receiver and upon its under side with a depending L-shaped lug for engaging the flanged disk or head of the locking-pin of the magazine, substantially as specified.

3. In a fire-arm, the combination with a firing-mechanism comprising a pivoted trigger having the rear notch 33, of the safety-lever loosely pivoted and arranged in rear of the trigger and having at its forward end the beveled finger 35 for engaging the notch and means for temporarily locking the safety-lever in engagement with the trigger, substantially as specified.

4. In a fire-arm, the combination with the firing-mechanism comprising the pivoted trigger having the rear notch 33, of the safety-lever loosely pivoted and arranged in rear of the trigger and having at its forward end the beveled finger 35 for engaging the notch, and the sliding catch 41 arranged for movement

in the receiver and adapted to engage a cavity in the rear end of the safety-lever, substantially as specified.

5. In a fire-arm, the combination with the receiver, the barrel, the magazine, and the reciprocating fore-arm, of the longitudinally movable breech-bolt carrying the firing-pin and provided with rack-teeth upon its under side, the toothed bar connected with the fore-arm, the pinion rotatably mounted between the teeth of the bar and bolt and engaging the two, the carrier arranged between the bolt and bar and a connection between the pinion and carrier to provide for actuating the latter by the rotation of the former, substantially as specified.

6. In a fire-arm, the combination with the receiver, the barrel, the magazine, the reciprocating fore-arm, the breech-bolt having teeth and carrying the firing-pin, and the rack-bar carried by the fore-arm, of the intermediate rotatable pinion engaging the teeth of the rack-bar and the bolt, a shoulder formed on the bolt, a bell-crank lever pivoted in rear of the shoulder above the bolt and having its terminals arranged at the sides of the pinion, and a trip-pin carried by the pinion for engaging the said terminal, substantially as specified.

7. In a fire-arm, the combination with the receiver, the barrel, the magazine, and the reciprocating fore-arm, of the rack-bar carried by the fore-arm, the toothed pinion meshing with the rack-bar, the reciprocating pin-carrying bolt arranged above the pinion and provided with teeth engaged by the pinion, of a shoulder on the upper side of the bar, a bell-crank lever pivoted in rear of the shoulder and adapted at one branch to form a stop for the same and having its opposite branch comprising divergent parts terminating in hooks, a pin arranged upon the pinion and adapted to engage the hooks for actuating the bell-crank lever and a carrier having a hook also adapted to be engaged by the pin carried by the pinion, substantially as specified.

8. In a fire-arm, the combination with the receiver, the barrel, the magazine, and the reciprocating fore-arm, of a reciprocating bored breech-bolt, the spring-actuated pin arranged therein, a spring actuated lever arranged upon the breech-bolt and having its front end normally depressed and terminating in a stop for the pin, the rear end of the lever extending through and beyond a shoulder formed on the bolt, of a rack-bar operated by the fore-arm, an intermediate pinion engaging teeth on the rack-bar and on the bolt so that a movement of the latter causes a movement of the former, a locking lever pivoted in rear of the locking shoulder on the bolt and adapted to engage therewith, arms extending downward from the locking-lever and embracing the pinion, pins extending from the pinion into and engaging the arms and adapted to actuate the same, substantially as specified.

9. In a fire-arm, the combination with the receiver, the barrel, the magazine, and the fore-arm, of the breech-bolt provided with a bore and upon its under side with a slot extending nearly from end to end thereof and at opposite sides of said slot with teeth, a pinion arranged below the bolt, actuating devices between the pinion and fore-arm, a sear having its front end provided with a beveled shoulder spring-pressed into the slot and extending into the bore, a spring-actuated firing-pin arranged in the bore and having a shoulder for engaging that of the sear, and a trigger for operating the same, substantially as specified.

10. In a fire-arm, the combination with the receiver, the barrel, the magazine, and the reciprocating fore-arm, of a rotatable pinion having a trip pin, a reciprocating breech-bolt carrying a firing-pin and having teeth meshing with the pinion, a toothed rack-bar connected with the fore-arm and engaging with the teeth of the pinion, the locking lever adapted to be engaged by said trip pin, and the carrier 49, also adapted to be engaged by said trip pin substantially as specified.

11. In a fire-arm, the combination with the receiver, the barrel, the magazine, and the fore-arm, of the rotatable pinion having pins extending therefrom, the rack-bar extending from the fore-arm and engaging the teeth of the pinion, the curved carrier-arm having a hook 53 in the path of a pin on the pinion and provided at its front end with a cartridge-supporting plate, substantially as specified.

12. In a fire-arm, the combination with the receiver, the barrel, the magazine, and the sliding fore-arm, of the toothed pinion, the rack-bar extending from the fore-arm and engaging said teeth, the transverse pin extending from the pinion, the carrier-arm pivoted adjacent to the pinion and having a hook 53 arranged in the path of the pin and provided in rear of its pivot with the extension 52, the trigger 30 pivoted in the bottom of the receiver and having the projections 31 and 32, the former arranged in the path of the extension 52, the sear having its rear end extending to and resting upon the projection 32 of the trigger, the spring for actuating the sear, the beveled shoulder at the front end of the sear, the slotted reciprocating breech-bolt, the slot of which receives the beveled end of the sear, the firing-pin having a shoulder for engagement by the sear, and means for moving the breech-bolt, substantially as specified.

13. In a fire-arm, the combination with the receiver, the trigger, the safety-lever arranged in rear and adapted to lock the trigger and having the upwardly disposed bell-crank arms provided at their angles with the inwardly disposed beveled lugs, the rack-bar connected with the fore-arm and adapted to move under the beveled lugs, a spring for depressing the safety-lever, a breech-bolt, a pinion for operating the same actuated by the rack-bars, a

firing-pin, and devices between the pin and trigger for liberating the former, substantially as specified.

14. In a fire-arm, the combination with the receiver, the barrel, the magazine, the reciprocating fore-arm, the trigger, the rack-bar secured to the fore-arm, the breech-bolt carrying the firing-pin and having a bore and below the same a communicating slot, and at the opposite side of the slot and upon its under side provided with teeth, of the transverse shaft arranged between the bolt and the rack-bar, the hub located loosely on the shaft, the opposite pinions arranged upon the hub and spaced apart, the transverse pin extending through the pinions and beyond the same, the said pinions having their inner sides at opposite points provided with recesses, the sear pivoted in rear of the pinions and having a forward beveled end extending through the slot of the breech-bolt into the bore thereof, the spring actuated shouldered firing-pin arranged in the bore, the spring for depressing the sear at its rear end, the carrier-arm pivoted in rear of the pinions and passing between the same and having the hook

adapted to be engaged by the pin of the pinions, substantially as specified.

15. In a fire-arm, the combination with the receiver, the barrel, the magazine, and the reciprocating fore-arm, the rack-bar connected with the fore-arm, and the pinion arranged above the rack-bar, of the superimposed reciprocating firing-pin-carrying breech-bolt having a shoulder, a locking-lever pivoted in rear of the shoulder above the bolt in a cavity in the receiver and adapted to drop into the path of said shoulder, said breech-bolt being provided upon its under side with teeth for the pinion and having a plain or un-toothed portion, devices between the pinion and locking-lever for operating the latter by revolution of the former, a carrier, and means for operating the same, substantially as specified.

In testimony that I claim the foregoing as my own I have hereto affixed my signature in the presence of two witnesses.

ALFRED LEE.

Witnesses:

D. W. FREEMAN,  
V. E. CODE.