



Europäisches Patentamt
European Patent Office
Office européen des brevets



(11) **EP 0 924 040 A1**

(12) **EUROPEAN PATENT APPLICATION**

(43) Date of publication:
23.06.1999 Bulletin 1999/25

(51) Int. Cl.⁶: **B28C 1/00, B28C 7/02**

(21) Application number: **97830681.9**

(22) Date of filing: **17.12.1997**

(84) Designated Contracting States:
**AT BE CH DE DK ES FI FR GB GR IE IT LI LU MC
NL PT SE**
Designated Extension States:
AL LT LV MK RO SI

(72) Inventors:
• **Casolari, Ivan**
41100 Modena (IT)
• **Fondriest, Gianni Pietro**
47030 Sogliano al Rubicone (Forlì) (IT)

(71) Applicant:
Esi Elettrosistemi S.r.l.
41100 Modena (MO) (IT)

(74) Representative: **Gotra, Stefano**
BUGNION S.p.A.
No. 25, Via Emilia Est
41100 Modena (IT)

(54) **A device for gauging the consistency of a mixture during mixing in a rotary recipient**

(57) A device (1) for gauging the consistency of a mixture being mixed inside a rotating recipient is usefully employed in particular with concrete mixtures in a mixer, and comprises a sensor (5) destined in use to be fixed to an internal wall of a rotating mixer body. During rotation of the body, the sensor (5) contacts the mixture and is thus subject to a deformation which is measured by a dynamometer, which then sends a signal corresponding to the deformation to a radio wave transmitter (10), through an amplifier-integrator (19). A radio-wave receiver (11), external of the rotating recipient (4), provides an operator with a reading on a display (20); after which the operator can add a desired quantity of water or another material to the mixture, up until a desired consistency of the mixture is reached.

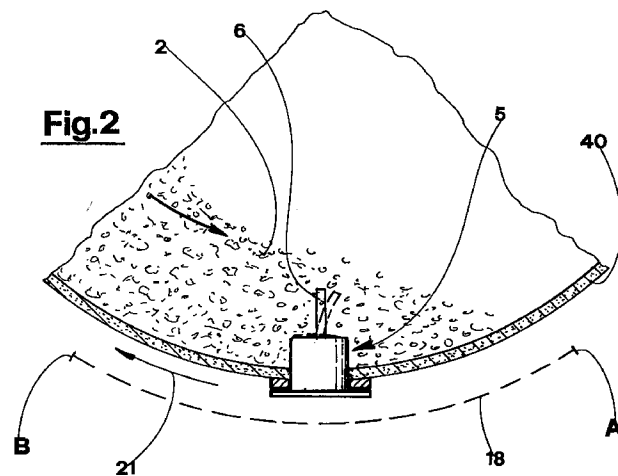

EP 0 924 040 A1

Description

[0001] The invention relates specifically, though not exclusively, to a device for gauging the consistency of concrete while it is being mixed in a mixer. This is often called the "slump" measurement, i.e. the workability of the mixture. In the following, reference will be made to this special type of use of the device, though its ambit of use is considerably more general.

[0002] During the preparation of concrete, the rotating drum of a mixer is filled with the basic ingredients (generally speaking, gravel, sand, crushed aggregate, cement and water), after which the ingredients are stirred by the rotation of the drum up until the correct mixture is obtained. Usually this preparation is done in two phases: firstly the various ingredients are introduced into the drum with only a small quantity of water, and mixed up until a fairly stiff concrete mixture is obtained. Then controlled quantities of water are added until the mixture is correct.

[0003] Obtaining this correct dosage of water can only be done by knowing the exact consistency of the mixture in the drum during the mixing phase.

[0004] At present this is achieved by gauging the oil pressure in the hydraulic motor circuit driving the drum. The greater or lesser pressure of this oil is considered a measure of the consistency of the mixture, and a greater or smaller quantity of water is accordingly added up until the pressure reaches an empirically predetermined correct consistency.

[0005] In reality, the consistency is only very approximately and imprecisely arrived-at, as the oil pressure depends not only on the consistency of the concrete but also on various other parameters, whose influence on the oil pressure is not at all easy to evaluate. These parameters comprise primarily the state of wear of the stirring paddles inside the drum, but the temperature of the hydraulic circuit oil itself is important, as are the quantity of concrete in the drum and the rotation speed of the drum, to mention only a few.

[0006] The main aim of the present invention is to obviate the abovementioned drawbacks in the prior art by providing a device for gauging the consistency of a mixture inside a rotating recipient. The device must be constructionally simple and economical, and must also be relatively precise and reliable.

[0007] One advantage of the invention is that it provides a device which measures the slump consistency and can be mounted rapidly and simply on a typical mixer of types already in use.

[0008] A further advantage of the invention is to enable an immediate reading of the consistency to be taken and to permit an automatic or semiautomatic correction of the dose of water to be added.

[0009] Further, advantageously the device does not exhibit mechanical connections between moving on-board mixer elements and fixed external elements of the mixer.

[0010] A further advantage is that the invention guarantees good precision over a high range of mixture consistency values. In the case of concrete, since the consistency depends mostly on the weight percentage of the various ingredients, the device is useful for all types of concrete, i.e. for whatever the desired dosing of the various ingredients.

[0011] These aims and advantages and more besides are all attained by the device of the invention, as it is characterised in the appended claims.

[0012] Further characteristics and advantages of the present invention will better emerge from the detailed description that follows of some preferred but non-exclusive embodiments of the invention, illustrated purely by way of non-limiting examples in the accompanying figures of the drawings, in which:

figure 1 is a schematic lateral view in vertical elevation, with some parts removed better to evidence others, of a truck mixer fitted with the object of the invention;

figure 2 is an enlarged-scale detail of the section made according to line II-II of figure 1;

figure 3 is a block diagram of the device;

figure 4 is an enlarged-scale drawing of a detail of figure 2;

figure 5 shows a view from below of figure 4;

figure 6 is a plan view from above of a sensor element, in a first embodiment;

figure 7 is a broken section according to line VII-VII of figure 6;

figure 8 is a plan view from above of a sensor element, in a second embodiment;

figure 9 is a broken view from below of figure 8;

figure 10 is a plan view from above of a sensor element, in a third embodiment;

figure 11 is a broken section made according to line XI-XI of figure 10;

figure 12 is a plan view from above of a sensor element in a fourth embodiment;

figure 13 is a broken section, made according to line XIII-XIII of figure 12;

figure 14 is a schematic section view of a detail of a further embodiment of the device;

figure 15 is a view from above of figure 14;

figure 16 is a detail of figure 15, sectioned according to line XVI-XVI.

[0013] With reference to the abovementioned figures of the drawings, 1 denotes in its totality a device for gauging the consistency of a mixture inside a rotating container, in particular destined for use in combination with a mixer 3 having a rotating drum 4, with an inclined rotation axis, in which a mass of concrete 2 is mixed. Figure 1 shows a mixer truck; the device 1 is, however, applicable to any other type of mixer provided with a rotating recipient

[0014] According to the invention, the device 1 com-

prises a sensor element 5, made of a metallic material (for example steel) and destined during use to be fixed to a wall 40 of the rotating recipient 4 of the mixer 3. The sensor 5, once mounted on the recipient 4, exhibits a projecting part 6 which extends internally of the recipient 4 and which, during rotation of the latter, comes into contact with the concrete mixture 2 inside the recipient 4, and is deformed thereby.

[0015] In the present embodiment, the sensor 5 is mounted on the recipient 4 through a hole made in the wall 40 of said recipient 4. It would also be possible to apply the sensor 5 on the inspection hatch normally present on a rotating recipient of a mixer, with no need to drill holes.

[0016] The projecting part 6 has the shape of a flat rectangular sheet, though other shapes could be chosen. The projecting part 6, which projects practically radially with respect to the rotation axis of the recipient 4, is solidly connected, indeed is of a single piece, with a circular plate part 12, perpendicular to the projecting part 6, having a first face 13 which faces internalwards of the recipient 4, and a second face 14, opposite to the first, in which two grooves 22 are cut, which are parallel to the projecting part 6 and situated on opposite sides with respect to said projecting part 6. These grooves 22 house dynamometrical means for sensing deformation in the sensor 5 during its interaction with the concrete mix 2, and of generating a signal resulting therefrom. The dynamometrical means are preferably constituted by a plurality of deformeters 17, of known type and here represented schematically.

[0017] The peripheral edge of the plate part 12 is made in a single piece with a hollow cylindrical part 7 having an axis which is perpendicular to the plate part 12.

[0018] The cylindrical part 7 passes through an aperture on the wall 40 of the rotating recipient 4 and terminates in a flanged part 23. A flange 24, fixed to the outside of the wall 40 of the rotating recipient 4 is coupled by means of fixing screws 27 to the flanged part 23. The flanged part 23 can be fixed to the flange 24 in a plurality of different positions, reachable by rotating the cylindrical part 7 about its axis. This means that the projecting part 6 of the sensor 5 can be positioned so that it presents its front face 50 (with reference to the direction 21 of rotation of the recipient 4) according to an inclination chosen from a plurality of possible inclinations.

[0019] Figure 3 schematically shows the device 1 which comprises, mounted solidly with the sensor 5 at the edge of the recipient 4, an amplifier-integrator 19 (of known type) of the signal provided by the dynamometer and a transmitter of radio waves 10 (or other radio magnetic waves) connected thereto. Both the amplifier-integrator 19 and the transmitter 10 are situated in the cavity of the cylindrical part 7 of the sensor 5, internally of which a battery 28 for current supply is housed. The cavity is inferiorly closed by a cover 29 which also func-

tions as a transmission antenna of the radio waves. In the internal cavity of the cylindrical part 7 is housed a battery charger of known type and not illustrated, for recharging the battery 28 by exploiting the rotation movement of the recipient 4. The automatic recharging means might be, for example, a spring motor of the sort used in automatic wrist watches, connected through a small dynamo to the battery 28.

[0020] The device 1 further comprises a measuring unit 9, fixed and external of the mixer 3. The measuring unit 9 comprises: a radio wave receiver 11 for receiving the radio signal (corresponding to the deformation of the sensor) emitted by the transmitter 10; and a display 20 for visualizing a measurement according to the signal received. The external measuring unit is advantageously structured and dimensioned so as to realise a portable and/or pocket-sized remote control unit.

[0021] The device 1 further comprises means (constituted for example by a gravimetric switch 16, possibly a mercury type, arranged internally of the cylindrical part 7) for activating the device according to the inclination of the sensor with respect to the vertical, so as to measure the deformation of the sensor only when it is in a lower tract 18 of its rotary course, during the rotation of the mixer recipient 4. This allows the sensor deformation to be measured only when its projecting part 6 is immersed in the mixture of concrete 2 and is in contact therewith.

[0022] In use, while the recipient 4 of the mixer 3 rotates in the direction of arrow 21, the projecting part 6 of the sensor 5 interacts with the concrete mixture and is accordingly deformed, consequently deforming the plate part 12 bearing the deformeters 17. In figure 2 the broken line (not in real scale) shows the deformation the sensor 5 is subjected to in use. The gravimetric switch 16 activates the device 1 when the sensor 5 enters the lower tract 18 of its circular pathway, i.e. at start point A of figure 2, and deactivates it at stop point B.

[0023] Thanks to the fact that the measurement of deformation is taken only when the sensor 5 passes through the lower tract 18, the dynamometers provide a continuous signal even when the recipient 4 is not completely full.

[0024] Should the consistency of the concrete be so stiff as to cause deformations which go beyond of the deformer measurement range, the deformation limit can be modified, simply by repositioning the sensor 5 by means of a rotation of the flanged part 23 on itself. In this way the direction of the impact between the front face 50 of the sensor 5 and the mass of concrete and thus the relative impact deformation are changed. Advantageously an automatic or operator radio-controlled motorised sensor rotation system can be provided for this purpose.

[0025] Through the chain of transmission constituted by the amplifier-integrator 19, the transmitter 10 and the receiver 11, the deformation signal read off by the deformer is visualised on the display, where it can be

read by an operator who, according to the value indicated by the display, adds one or more ingredients to the concrete mixture in the recipient 4 until the desired consistency is reached. As has been mentioned, a water-poor mixture is advisable at the start of the process, with water then being added until the value the display shows that a predetermined sample value has been reached, corresponding to the optimal consistency. This sample value, which can be predetermined empirically, obviously depends on various parameters, among which are the type of concrete to be obtained and the velocity of the recipient drum during the mixing phase.

[0026] During mixing the gravimetric switch 16 can measure the mixer drum velocity, simply by timing its own passage between two consecutive apertures of the switch itself through point A.

[0027] The device can function automatically, using, for example, a computer containing empirically-obtained memorized reference data, which computer receives the deformation signal, processes it according to said memorized data and the rotation velocity of the recipient 4, and consequently commands a known device to introduce dosed quantities of water (or another ingredient) into the mixer recipient 4.

[0028] Figures 8 and 9 show a sensor 25 provided with a projecting part 26 which is solid to a plate-shaped part 32 and which exhibits, in proximity of the connection zone with said plate-shaped part 32, two parallel grooves 31, situated on opposite sides of the projecting part 26 and destined to house dynamometers able to measure the deformation of the projecting part 26 (for example deformeters).

[0029] The two sensors shown in figures from 10 to 13 and indicated respectively by 35 and 45 are provided with a projecting part, respectively 36 and 46, slightly arched and thus exhibiting a concave surface, respectively 15 and 30, which is destined to interact with the concrete mixture 2 and which faces forwards with reference to the advancement direction (arrow 21) of the sensor with respect to the concrete mixture 2 during the rotation of the recipient 4. 41 and 42 denote the plate-shaped parts made in a single piece with the projecting parts 36 and 46 and perpendicular thereto, while 37 and 47 respectively denote the grooves which house one or more deformeters.

[0030] Some of the preferred arrangements of the deformeters are indicated on the sensor. Other arrangements, however, could be made.

[0031] The arched shape of the projecting parts 36 and 46 advantageously enables accurate sensor deformation measurements, giving good concrete consistency references, without its being necessary for the mixture in the mixer to be perfectly mixed. As it is possible to know the concrete consistency before the mixture reaches its optimal mixture degree, concrete mixing time is reduced.

[0032] In figures from 14 to 16 a sensor 55 is shown

which corresponds to the diagram mapped in figure 3, apart from the substitution of the sensor 5 with sensor 55, which will be described herein below.

[0033] The sensor 55 exhibits a projecting part 56 which projects internally of the recipient 4 to which it is applied, and which during the recipient rotation, interacts with the mixture being mixed and so is subject to deformation.

[0034] The projecting part 56 is externally cylinder-shaped and projects in more or less radial direction with respect to the recipient 4 rotation axis. The projecting part 56 is mounted by means of a screw connection 62 on a hollow support 57 made solid to the wall 40 of the recipient 4. The sensor 56 comprises an external mantle 57, which in the illustrating example is cylindrical and made in two parts 58a and 58b. The mantle 58 internally defines a cavity housing an internal nucleus 59, also being a part of the projecting part 56 of the sensor 56.

[0035] A first part 58b of the mantle 58, which has the shape of an internally hollow cylindrical sleeve, is situated inferiorly to and in contact with an upper flat surface of the support 57. The nucleus 59 is inserted in the cavity of the first part 58b. A second part 58a of the mantle, which is located superiorly to the first part 58b, inferiorly exhibits a recess housing the upper part of the nucleus 59. The external mantle 58 and the internal nucleus 59 are made reciprocally solid, for example by means of a screw connection 64 which joins the nucleus 59 to the second, upper part 58a of the mantle. The external mantle 58 and the internal nucleus 59 can thus interact with one another.

[0036] Dynamometers sensitive to the deformation of the nucleus are associated to the nucleus 59. These dynamometers preferably comprise deformeters. The nucleus 59 is internally provided with a central cavity 60 in part occupied by a relatively slim diaphragm 61, constrained to the nucleus 59 and indeed, in the illustrated example, made in a single piece therewith. The deformeters are preferably applied to the diaphragm 61 and thus specifically measure the deformation of the diaphragm itself.

[0037] During use, the deformations undergone by the mantle 58, which interacts directly with the mixture during the mixing phase, are transmitted to the nucleus 59 and thus to the diaphragm 61 which is internal and solidly connected to the nucleus 59. The deformeters measure the entity of the deformations and send a signal to the amplifier-integrator housed in the internal cavity of the support 57, after which the signal transmission chain is the same as in the preceding examples. The deformeters can be connected to the amplifier-integrator through connection wires 63 which pass through a hole made coaxially internally of the screw connection 62.

[0038] The device of the invention can be powered by solar batteries applied to the cover of the cavity itself; which faces externally of the recipient 4. This is shown

in figures 14 to 16.

[0039] In an embodiment of the device, not illustrated in the figures, dynamometers can be used which measure the deformations undergone by the sensor in at least two predetermined and different directions, which are preferably, though not necessarily, coplanar and reciprocally perpendicular. The measurement of the deformations in at least two directions, rather than in one alone, means that the degree of workability of the mixture can be gauged with considerable precision, whatever the kind of rotating recipient used.

Claims

1. A device (1) for gauging the consistency of a mixture (2) being mixed inside a rotating recipient (4), characterised in that it comprises:
 - a sensor (5, 25, 35, 45, 55) destined in use to be constrained to a wall (40) of said recipient (4), and exhibiting at least one projecting part (6, 26, 36, 46, 56) which projects internalwise of the recipient (4) and which during a rotation of said recipient (4) can interact with the mixture (2) in such a way that said interaction causes a deformation of said sensor (5, 25, 35, 45, 55);
 - a dynamometer for measuring the deformation of said sensor (5, 25, 35, 45, 55) and able to provide a signal which corresponds to said deformation;
 - means for transmitting said deformation signal provided by the dynamometer to a measuring unit (9) which is external of the rotating recipient (4).
2. The device of claim 1, characterised in that said means for transmitting comprise a radio wave transmitter (10) connected to the sensor (5) and connected to a radio wave receiver (11) associated to the measuring unit (9).
3. The device of claim 1 or 2, characterised in that it comprises means for activating said dynamometer according to an inclination of the sensor (5) with respect to the vertical, in such a way as to measure a deformation of the sensor (5) only when said sensor (5), during a rotation of the recipient (4) to which it is constrained, is located in a lower tract (18) of a full rotation revolution, said means for activating preferably comprising a gravimetric switch (16).
4. The device of any of the preceding claims, characterised in that said dynamometer comprises at least one deformer (17) applied to the sensor (5).
5. The device of any one of the preceding claims, characterised in that the sensor (5) comprises a plate-shaped part (12), solidly constrained to the projecting part (6) and transversal thereto, having a first face (13) comprising said projecting part (6) and a second face (14), opposite to said first face (13), to which said dynamometer is associated, preferably at a connection zone with a plate-shaped part (32, 42) transversal to the projecting part (26, 46) and solidly connected thereto.
6. The device of any one of the preceding claims, characterised in that the sensor (5) is positionable on the wall (40) of the recipient (4) in such a way that the projecting part (6) can selectively assume a plurality of inclinations with respect to a impact direction of said sensor (5) with said mixture (2).
7. The device of any one of the preceding claims, characterised in that it comprises, solidly constrained to the sensor (5): a battery (28) for supplying said dynamometer and said means for transmitting associated to the sensor(5); and means for recharging said battery (28), exploiting the rotation of the recipient (4).
8. The device of any one of the preceding claims, characterised in that the projecting part (36, 46) exhibits a concave surface (15, 30) destined to interact with the mixture (2) and facing forwards with reference to an advancement direction (21) of the sensor (5) with respect to the mixture (2) during a rotation of the recipient (4).
9. The device of any one of the preceding claims, characterised in that the projecting part (56) comprises a external mantle (58) which can interact with an internal nucleus (59), to which nucleus (59) the dynamometer is associated, which dynamometer preferably measures the deformations of a diaphragm (61) made solid to the nucleus (59).
10. The device of any one of the preceding claims, characterised in that the dynamometer measures the deformations that the sensor undergoes in at least two directions.
11. The device of any one of the preceding claims, characterised in that said mixture is concrete.

Fig.1

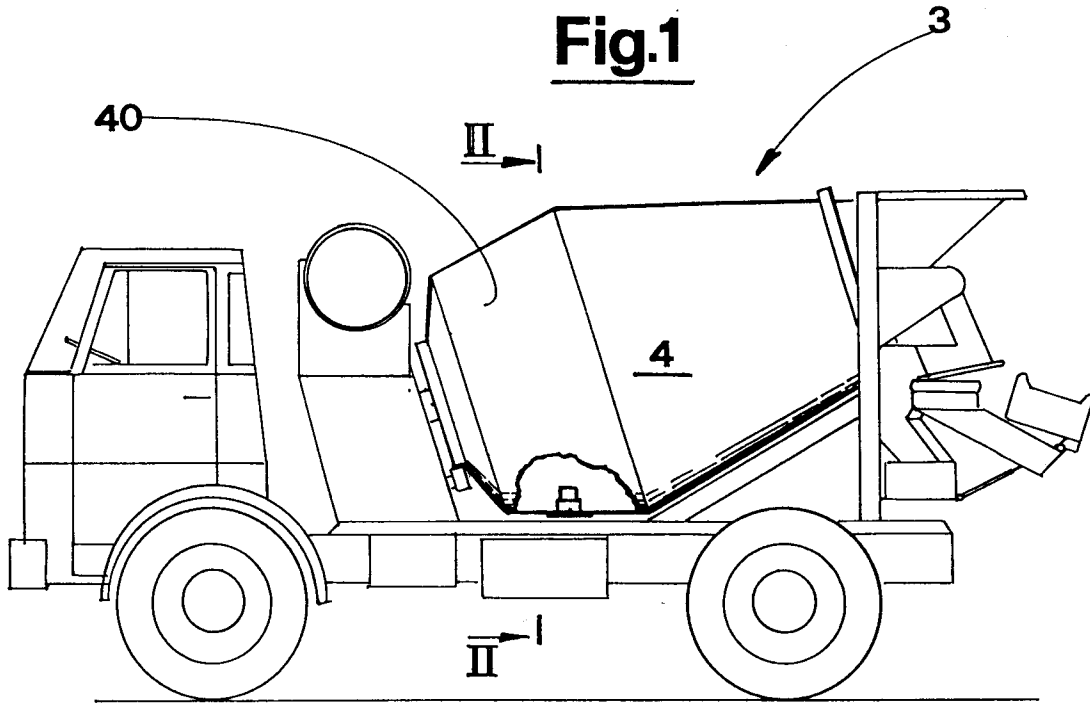
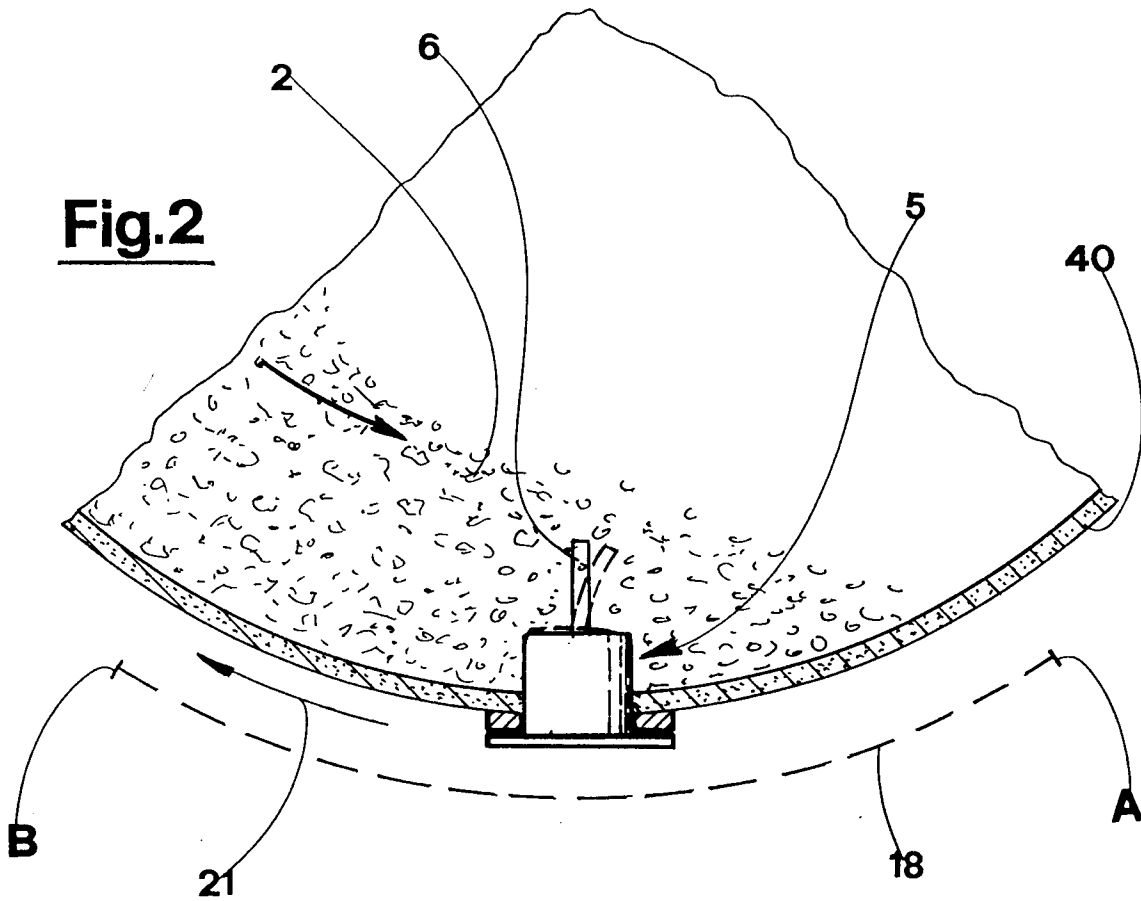

Fig.2



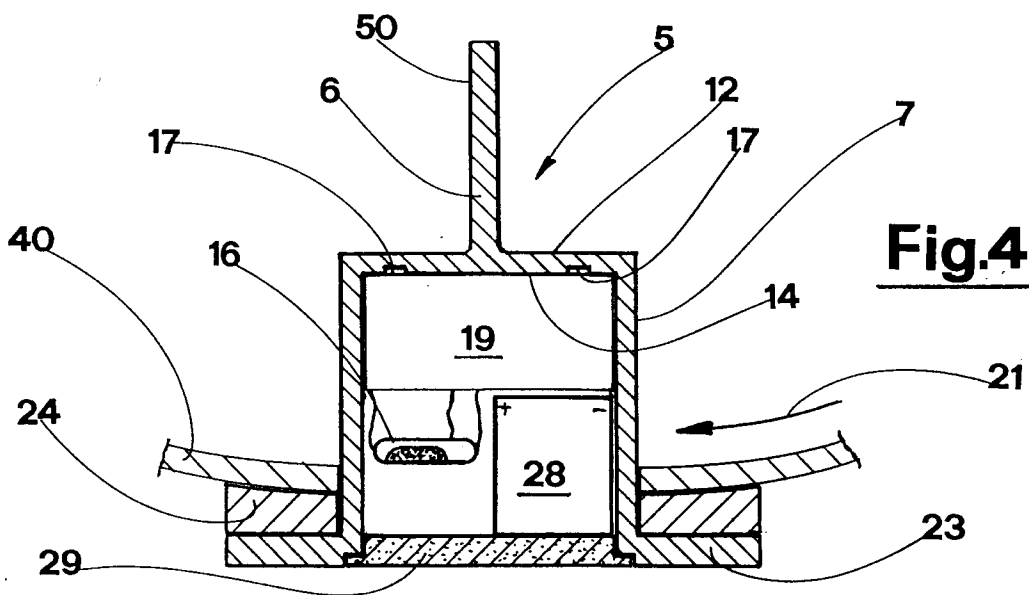
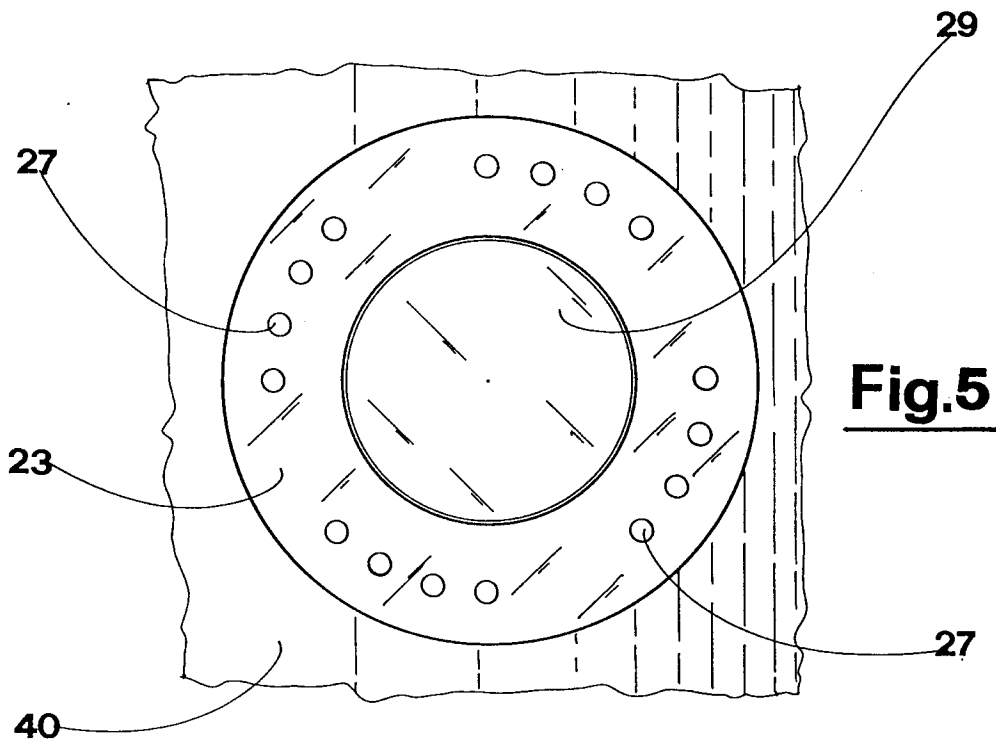
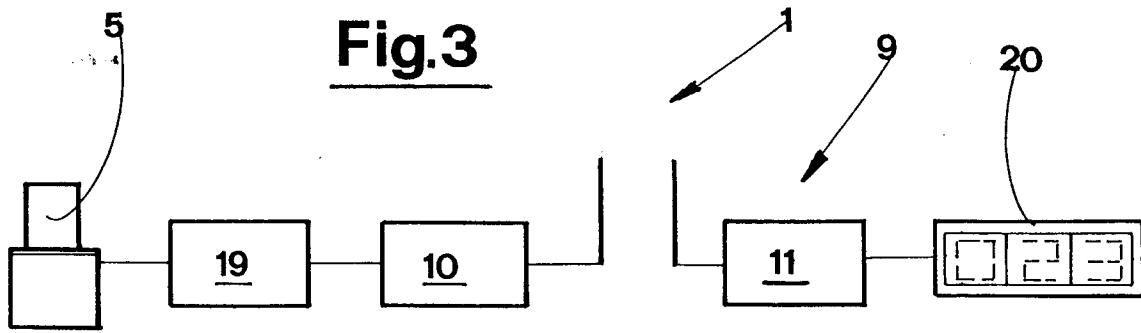

Fig.9

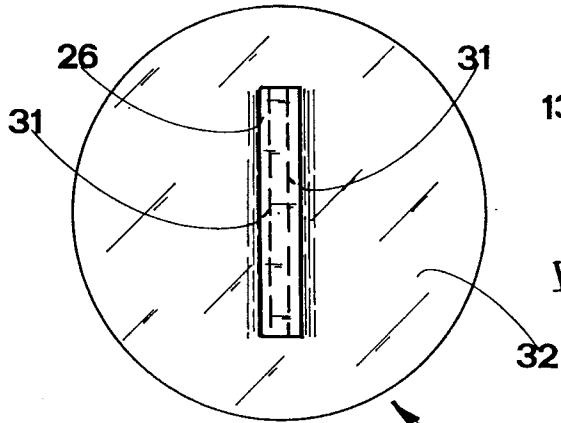
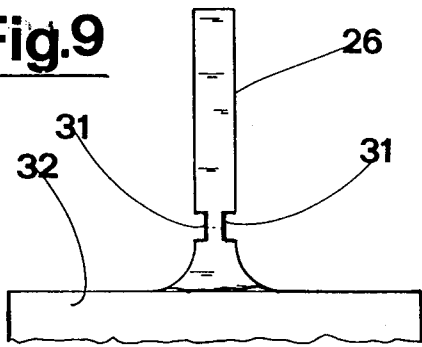

Fig.8

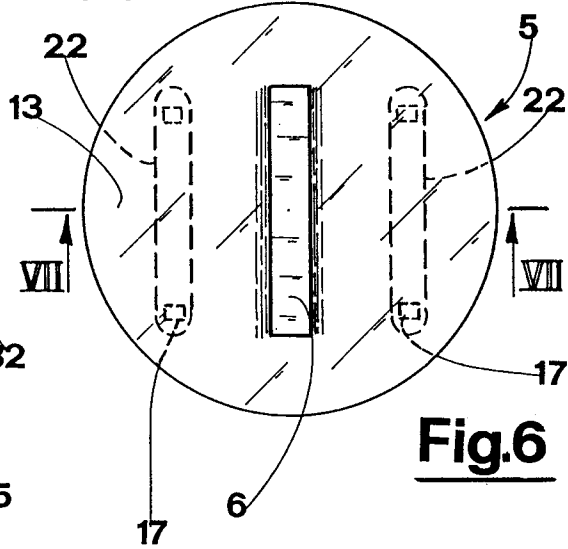
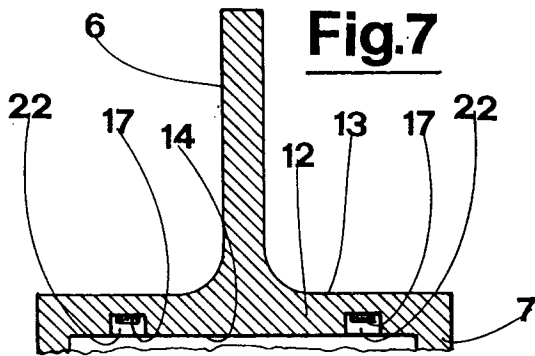

Fig.6

Fig.13

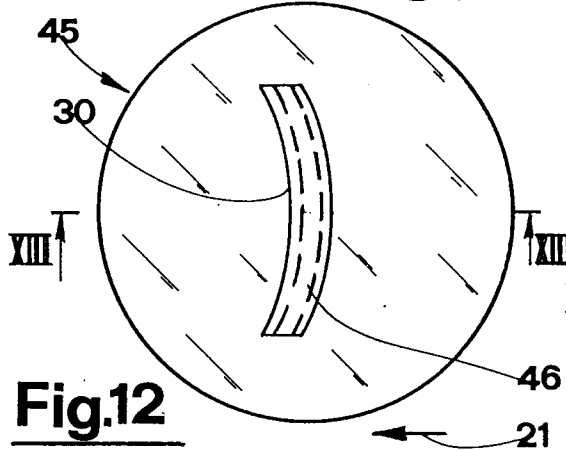
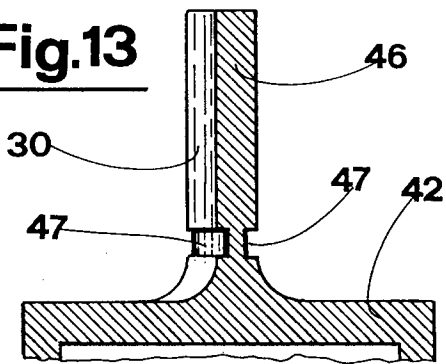

Fig.12

Fig.11

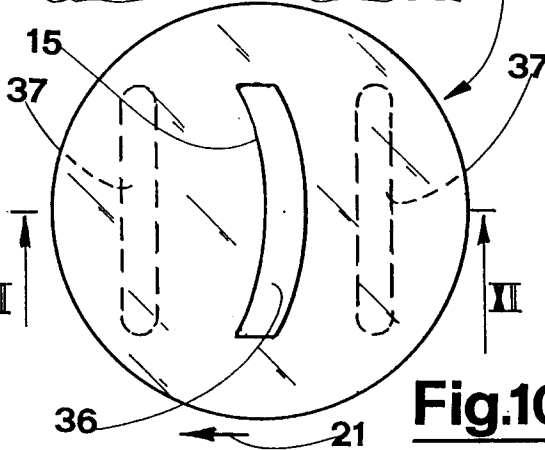
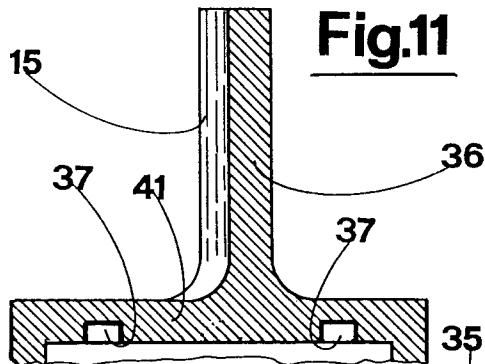

Fig.10

Fig.16

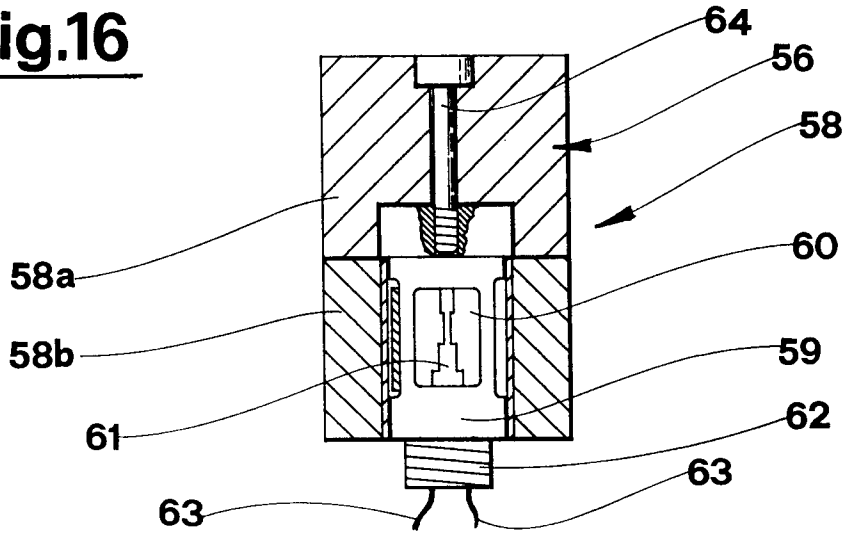

Fig.15

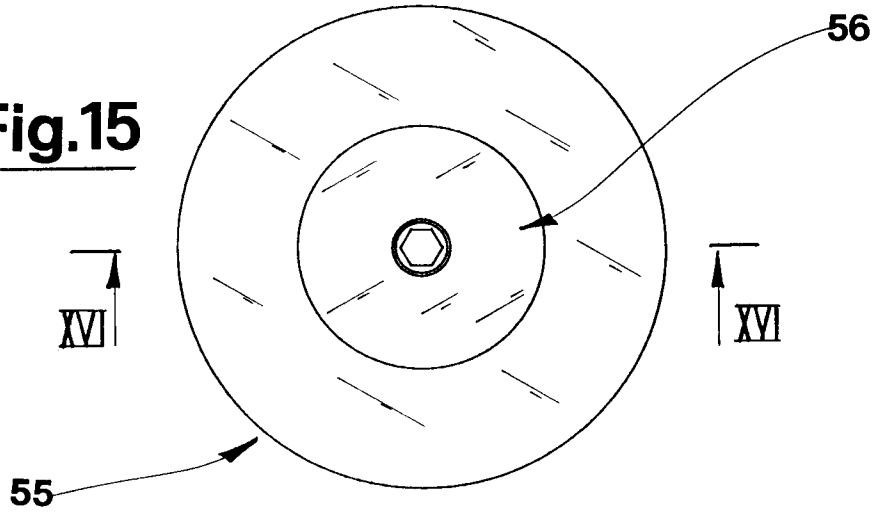
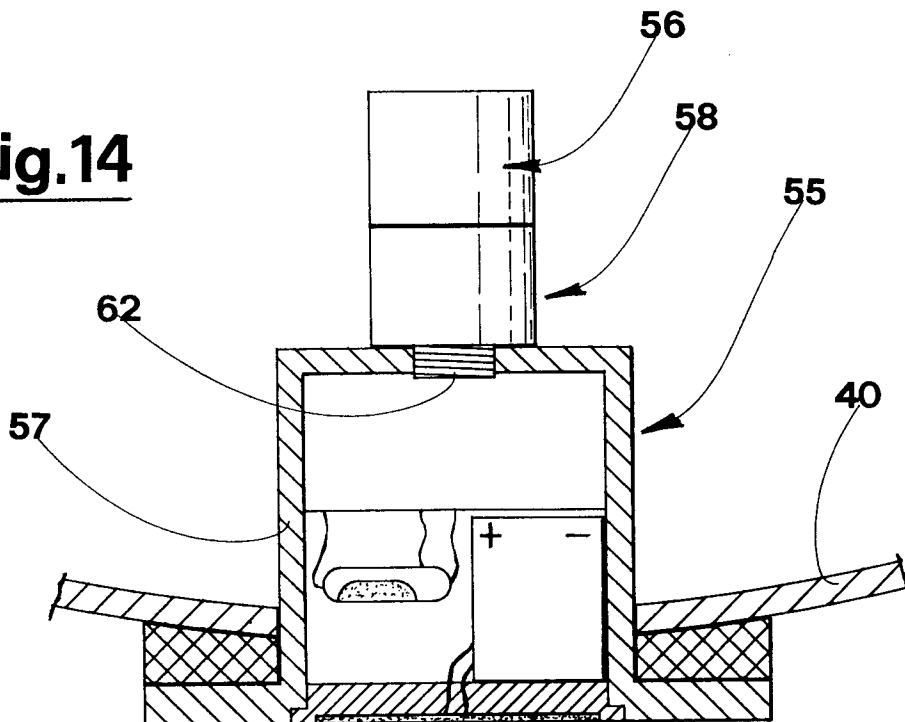

Fig.14





European Patent Office

EUROPEAN SEARCH REPORT

Application Number
EP 97 83 0681

DOCUMENTS CONSIDERED TO BE RELEVANT			
Category	Citation of document with indication, where appropriate, of relevant passages	Relevant to claim	CLASSIFICATION OF THE APPLICATION (Int.Cl.6)
X	US 4 900 154 A (WAITZINGER FRANZ ET AL) 13 February 1990	1-11	B28C1/00 B28C7/02
Y	* abstract; claims; figures * * column 1, line 46 - column 3, line 2 * * column 6, line 4 - column 6, line 48 *	6	
Y	WO 92 15437 A (ASSH DANIEL) 17 September 1992 * abstract; claims 1-10; figures * * page 6, line 11 - page 10, line 11 *	1-11	
Y	US 4 332 158 A (OSBORNE HOWARD S) 1 June 1982 * abstract; figures; examples * * column 1 *	1-11	
T	US 5 713 663 A (BRIEDIS HUSSEIN ET AL) 3 February 1998 * abstract; claims; figures * * column 1 *	1-11	
A	WO 95 19221 A (STEWART & STEVENSON SERVICES I) 20 July 1995 * abstract; claim 1; figure 1 *	1-11	TECHNICAL FIELDS SEARCHED (Int.Cl.6) B28C B01F
The present search report has been drawn up for all claims			
Place of search THE HAGUE		Date of completion of the search 4 June 1998	Examiner Dugdale, G
<p>CATEGORY OF CITED DOCUMENTS</p> <p>X : particularly relevant if taken alone Y : particularly relevant if combined with another document of the same category A : technological background O : non-written disclosure P : intermediate document</p> <p>T : theory or principle underlying the invention E : earlier patent document, but published on, or after the filing date D : document cited in the application L : document cited for other reasons</p> <p>& : member of the same patent family, corresponding document</p>			

EPO FORM 1503 03.82 (P04C01)