

C. E. PERSON.
SIGNAL VALVE.

APPLICATION FILED JUNE 7, 1909.

949,840.

Patented Feb. 22, 1910.

FIG. 1.

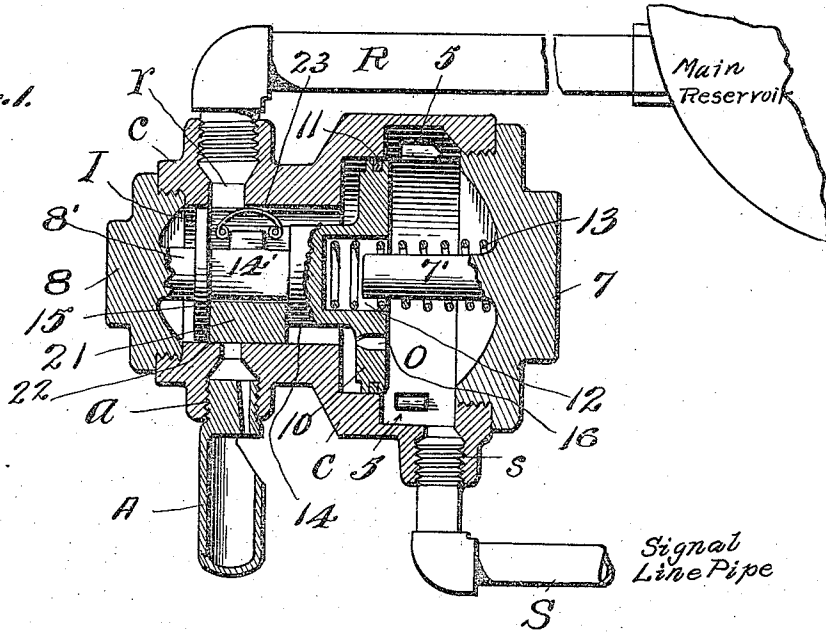

FIG. 2.

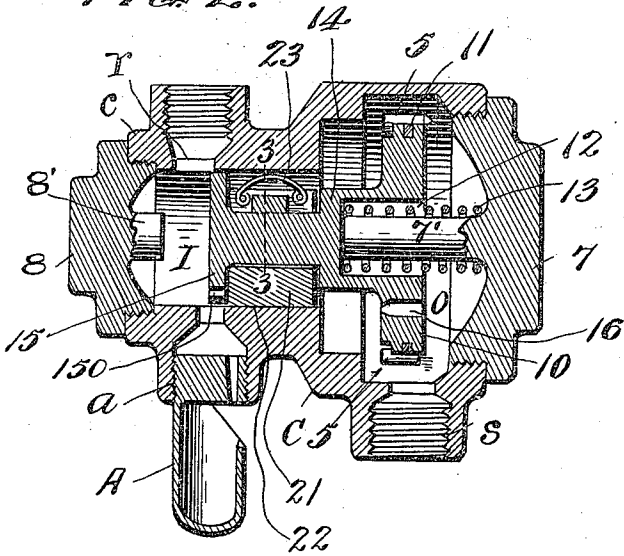
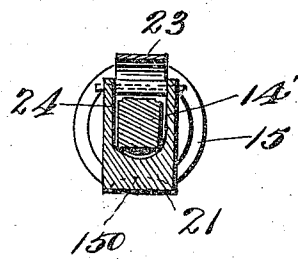

FIG. 3.



WITNESSES:

Chas. T. Davies,
Edith L. Smith

INVENTOR:

Carl E. Person,
by Ina C. Graham, Attorney

UNITED STATES PATENT OFFICE.

CARL E. PERSON, OF CLINTON, ILLINOIS.

SIGNAL-VALVE.

949,840.

Specification of Letters Patent. Patented Feb. 22, 1910.

Application filed June 7, 1909. Serial No. 500,779.

To all whom it may concern:

Be it known that I, CARL E. PERSON, a citizen of the United States, and resident of Clinton, in the county of Dewitt and State of Illinois, have invented certain new and useful Improvements in Signal-Valves, of which the following is a specification.

This invention relates to railway brakes employing fluid pressure, and more especially to the engineer signals used in connection with such brake systems and by which he may be signaled from any point in the train by a train hand who reduces the pressure in the signal line; and the object of the same is to produce an improved signal valve possessing the combined attributes of durability, compactness, efficiency, and accessibility, and especially one in which no reducing valve is necessarily employed.

To this end the invention consists in the structure hereinafter described whereby a reduction of pressure in the signal line permits the reservoir pressure to move the valve and connect its inlet with the signal, the parts being restored to their normal closed position as soon as the pressure in the signal line becomes again equal to that in the reservoir.

In the accompanying drawings—Figure 1 is a vertical section through the casing and its parts, showing the valve as closed; Fig. 2 is a similar section showing the valve as open; and Fig. 3 is a section on the line 3—3 of Fig. 2.

Referring to the drawings, the letter C designates the casing of this valve which is preferably round in contour and reduced at one end as at *c*, and at its upper side this reduced portion is tapped as at *r* for the reception of the inlet pipe R leading from the main reservoir usually located on a locomotive; and substantially opposite the inlet *r* (which in this case would be in the bottom of said reduced portion) the same is tapped as at *a* for an outlet to the alarm or signal A which may be a whistle as shown. At some point in the larger end of the casing (here shown in the bottom thereof) the same is tapped as at *s* for reception of the signal line pipe S which extends throughout the train and has valves at intervals for manipulation by the train hands as will be understood. By preference the ends of the casing are closed by removable caps 7 and 8 screwed into the casing as shown whereby

its interior is readily accessible at all times, and these caps have inwardly projecting studs 7' and 8' preferably standing along the axis of the casing. The latter in the interior wall of its larger part is provided with by-pass openings 5 arranged about as shown with reference to the outlet *s* to the signal line.

Within the larger part of the casing moves a piston 10 fitted therein by a packing ring 11 and cupped at its center as at 12 to receive the stud 7' and an expansive spring 13 which is coiled around the same, and the stem 14 of this piston is reduced exteriorly so that its diameter is smaller than the internal diameter of the small end of the casing, then further reduced as at 14', and finally provided with a flat head 15 remote from the piston and which is adapted to be forced into contact with the stud 8' by the expansion of the spring 13. This structure of the piston and its stem produces an inlet chamber I at one side of the piston and around said stem and an outlet chamber O at the other side of the piston and in communication with the signal line; and these two chambers are in constant communication by a fine port 16 through the piston, open at all times and by means of which the pressure from the reservoir makes up for leakage in the signal line.

While the signal valve proper may be of any approved type, I have herein shown it as consisting of a slide valve 21 mounted over the outlet *a* to the alarm and pressed onto the flat face or seat 22 surrounding the same by means of a spring 23 at the top of the valve which makes contact with the interior of the small end of the casing at the opposite side. The piston stem 14 is reduced and flattened as at 14' to permit the valve 21 to straddle the same as at 24. It is obvious that the inlet of pressure through the port *r* (being opposite the port *a*) will tend to assist in holding this valve upon its seat 22, or might alone be sufficient if the spring 23 were omitted. The head 15 holds the arms of this valve in place as perhaps best illustrated in Figs. 1 and 2.

With the parts standing as in Fig. 1, pressure from the main reservoir is admitted to the chamber I and through the fine port 16 to the pipe S so as to overcome leaks therein and equalize the pressure on opposite sides of the piston. When a train man

desires to signal the engineer, he opens some valve within the pipe S which reduces the pressure in chamber O and the reservoir pressure on the opposite side of the piston then overcomes the force of spring 13 and moves the parts to the position shown in Fig. 2. This simultaneously opens the by-pass ports 5 and direct connection between the inlet port *r* and the alarm A, and the latter is sounded. In a short time the pressure flowing through the by-pass ports will equalize itself on both sides of the piston and will make up for what pressure was exhausted from the pipe S, after which the spring will restore the parts to the position of Fig. 1 whereby the slide valve 21 cuts off the flow of pressure from the reservoir to the alarm.

Thus it will be seen that this invention obviates the necessity for a reducing valve, thereby economizing considerably in the cost of production and in the size of the whole. The device will work either upright or horizontal, and by preference it hangs between the main reservoir pipe and the signal line and on account of its size can be placed in the cab and quite near the engineer. This also produces a saving in piping and obviates the necessity for a loud signal or for further complication which would be expensive. The head 15 is cut away as shown at 150 for the purpose of allowing air to pass under the stem and over the valve 21, in which case the spring 23 could be omitted entirely if desired although I prefer to employ it.

What is claimed as new is:

1. In a signal valve for air brake systems, the combination with a casing, a signal whose outlet port communicates therewith, and a slide valve movable across and controlling said port; of the main reservoir, an inlet pipe leading thence into the casing at a point opposite said port, a signal line pipe leading into the casing at a remote point, a piston movable within the casing between and at right angles to said pipes, and connections between said piston and valve.

2. In a signal valve for air brake systems, the combination with a casing having its bore reduced at one end, a signal whose outlet port communicates with the bottom of the reduced portion, and a slide valve movable horizontally across said port; of the main reservoir, an inlet pipe leading thence into the top of the casing at a point opposite said port, a signal line pipe leading into the larger portion of the casing, a piston movable within said larger portion between said pipes and having a stem projecting loosely into the smaller portion, and connections between said stem and valve.

3. In a signal valve for air brake systems, the combination with a casing having its bore reduced at one end and flattened on

the bottom to form a valve seat, a signal whose inlet port communicates with the casing through said seat, a slide valve moving on the latter to control the port, and means for pressing the valve to its seat; of the main reservoir, an inlet pipe leading thence into the top of the casing at a point opposite said port, a signal line pipe leading into the larger portion of the casing, a piston movable within said larger portion between said pipes and having a stem projecting loosely into the smaller portion, and connections between said stem and valve.

4. In a signal valve for air brake systems, the combination with a casing having its bore reduced at one end and flattened on the bottom to form a valve seat, a signal whose inlet port communicates with the casing through said seat, a slide valve moving on the latter to control the port, and means for pressing the valve to its seat; of the main reservoir, an inlet pipe leading thence into the top of the casing at a point opposite said port, a signal line pipe leading into the larger portion of the casing, a piston movable within said larger portion between said pipe and having a stem projecting loosely into the smaller portion and flattened therein, the valve being forked and standing astride the flattened portion, and a head at the extremity of the stem beyond said valve.

5. In a signal valve for air brake systems, the combination with a casing having substantially opposite inlet and outlet ports near one end, connections between the former and the main reservoir, a signal connected with the outlet port, and a slide valve controlling said port; of a signal line pipe leading into the casing at a remote point, studs projecting inward from the ends of the casing, a piston between said studs within the casing, the latter having by-pass ports adapted to bridge the piston when at one extreme of its movement, a spring surrounding one of said studs and compressed when the piston stands at this extreme, and connections between said piston and valve.

6. In a signal valve for air brake systems, the combination with a casing having substantially opposite inlet and outlet ports near one end, connections between the former and the main reservoir, a signal connected with the outlet port, and a slide valve controlling said port; of a signal line pipe leading into the casing at a remote point, studs projecting inward from the ends of the casing, a piston movable between said studs within the casing, the latter having by-pass ports adapted to bridge the piston when at one extreme of its movement, a spring surrounding one of said studs and compressed when the piston stands at this extreme, a stem projecting from the opposite side of the piston and adapted to contact

with the other stud when the piston is at the opposite extreme of its movement, and connections between said valve and stem.

5 7. In a signal valve for air brake systems, the combination with a casing whose bore is reduced at one end and flattened at its bottom to form a valve seat and whose inner wall is cored with by-pass ports in its larger portion, a signal whose outlet port leads 10 through said seat, a slide valve controlling this port, and a main reservoir whose inlet pipe leads through the casing substantially opposite said outlet port; of studs projecting axially inward into the larger and smaller 15 portions of the casing, a coiled expansive spring surrounding the former stud, a piston in the larger portion of the casing cupped to receive said stud and spring and having a stem projecting into the smaller 20 portion and adapted to contact with the opposite stud, the slide valve being forked and mounted loosely on said stem, and the piston being provided with a fine hole, all for the purpose set forth.

25 8. In a signal valve for air brake systems, the combination with a casing whose bore is reduced at one end and flattened at its bottom to form a valve seat and whose inner

wall is cored with by-pass ports in its larger portion, a signal whose outlet port leads 30 through said seat, a slide valve controlling this port, and a main reservoir whose inlet pipe leads through the casing substantially opposite said outlet; of removable caps closing the ends of said casing and having 35 studs projecting axially inward into the larger and smaller portions of the casing, a coiled expansive spring surrounding the former stud, a piston in the larger portion of the casing cupped to receive said stud 40 and spring and having a stem projecting into the smaller portion and provided at its extremity with a head guided therein and adapted to contact with the opposite stud, the slide valve being forked and mounted 45 loosely on said stem behind the head, and the piston being provided with a fine hole, all for the purpose set forth.

In testimony whereof I sign my name in the presence of two subscribing witnesses, 50 this the 1st day of June, 1909.

CARL E. PERSON.

Witnesses:

E. B. MITCHELL,
CHAS. M. FULLER.