

(19) **DANMARK**

(10) **DK/EP 3218536 T3**



(12)

Oversættelse af
europæisk patentskrift

Patent- og
Varemærkestyrelsen

-
- (51) Int.Cl.: **D 01 D 5/00 (2006.01)**
- (45) Oversættelsen bekendtgjort den: **2019-08-19**
- (80) Dato for Den Europæiske Patentmyndigheds bekendtgørelse om meddelelse af patentet: **2019-05-15**
- (86) Europæisk ansøgning nr.: **15859271.7**
- (86) Europæisk indleveringsdag: **2015-11-10**
- (87) Den europæiske ansøgnings publiceringsdag: **2017-09-20**
- (86) International ansøgning nr.: **IL2015051086**
- (87) Internationalt publikationsnr.: **WO2016075688**
- (30) Prioritet: **2014-11-11 US 201462077916 P**
- (84) Designerede stater: **AL AT BE BG CH CY CZ DE DK EE ES FI FR GB GR HR HU IE IS IT LI LT LU LV MC MK MT NL NO PL PT RO RS SE SI SK SM TR**
- (73) Patenthaver: **Nanomedic Technologies Ltd., 2 Yodfat St., Global Park, Northern Industrial Zone, Lod, Israel**
- (72) Opfinder: **DUBSON, Alexander, 15 Mota Gur St., 76634 Rehovot, Israel**
- (74) Fuldmægtig i Danmark: **RWS Group, Europa House, Chiltern Park, Chiltern Hill, Chalfont St Peter, Bucks SL9 9FG, Storbritannien**
- (54) Benævnelse: **BÆRBAR ANORDNING TIL ELEKTROSPINNING**
- (56) Fremdragne publikationer:
WO-A2-2014/118585
CN-U- 202 968 788
CN-U- 203 754 859

DESCRIPTION

FIELD OF THE INVENTION

[0001] The present invention relates to an electrospinning device and, more particularly, to a portable electrospinning device useful in providing dressing -like coatings on wounds and the like.

BACKGROUND OF THE INVENTION

[0002] Electrospinning is a simple and effective method for producing fibers from tens of nanometers to micrometers. In the electrospinning process, a polymer solution from a reservoir is ejected to a small opening of a capillary by means of Coulomb repulsion of charges that are accumulated at the tip of a pendant droplet as soon as an electrical potential applied between the capillary and a collecting device increases beyond a critical value. As the charged jet travels to the collector, it readily dries out, forming nonwoven fibrous mats depositing on the collector. Due to the ability of fibrous mats and their porous nature, electrospun fibrous webs could be excellent functional wound dressing materials. The porous nature of these mats is highly suitable for the drainage of the wound exudates and, allows appropriate permeation of atmospheric oxygen to the wound. They can be specially made to prevent wounds from attacks of microbes, thus to refrain the wound from possible infections, which would ultimately result in delayed healing.

[0003] WO/2010/059127 discloses a portable electrospinning apparatus for generating fibres comprising: at least one reservoir for holding at least one electrospinning medium; an outlet for dispensing the electrospun fibres; a grounded electrode for contacting a surface onto which the fibres are deposited; and a hollow elongate device adapted to connect to the outlet, the hollow elongate device being capable of directing the dispensed fibres towards a pre-determined direction. The present invention also provides a construct for grounding at least one surface, wherein the construct is flexible to substantially conform to the shape of the at least one surface.

[0004] US 6753454 discloses a novel fiber comprising a substantially homogeneous mixture of a hydrophilic polymer and a polymer which is at least weakly hydrophobic. The fiber optionally contains a pH adjusting compound. A method of making the fiber comprises electrospinning fibers of the substantially homogeneous polymer solution. A method of treating a wound or other area of a patient requiring protection from contamination comprises electrospinning the substantially homogeneous polymer solution to form a dressing. An apparatus for electrospinning a wound dressing is disclosed.

[0005] US 7794219 discloses an electrospinning device for generating a coat from a liquefied

polymer. The device comprises: (a) a dispenser for dispensing the liquefied polymer; (b) a cavity having a longitudinal axis, comprising a first system of electrodes; the dispenser and the first system of electrodes being constructed and design such that the liquefied polymer is dispensed from the dispenser and forms a plurality of polymer fibers moving along the longitudinal axis; and (c) a mechanism for relocating the polymer fibers out of the cavity, in a direction of an object, so as to generate a coat on the object.

[0006] Shi-Cong Xu et al (Nanoscale, 2015, 7, 12351) describes an electrospinning apparatus (BOEA) based on miniaturization and integration. The device gets liberated from the conventional heavy power supply, achieves the tight integration of functional parts and can be operated by a single hand due to its small volume ($10.5 \times 5 \times 3 \text{ cm}^3$) and light weight (about 120 g). Different polymers such as polyvinylpyrrolidone (PVP), polycaprolactone (PCL), polystyrene (PS), poly(lactic acid) (PLA) and poly(vinylidene fluoride) (PVDF) were electrospun into fibers successfully, which confirms the stable performance and good real-time control capability of the apparatus. These results demonstrate that the BOEA could be potentially applied in many fields, especially in biomedical fields such as skin damage, wound healing, rapid hemostasis, etc.

[0007] Pierre-Alexis Mouthuy (Biotechnol Lett (2015) 37:1107-1116) reports about a small, battery-operated electrospinning apparatus which enables control over the voltage and the flow rate of the polymer solution via a microcontroller. It can be used to electrospin a range of commonly used polymers including poly(ϵ -caprolactone), poly(p -dioxanone), poly(lactic-co-glycolic acid), poly(3-hydroxybutyrate), poly(ethylene oxide), poly(vinyl alcohol) and poly(vinyl butyral). Moreover, electrospun meshes are produced with a quality comparable to a benchtop machine. It is shown that the portable apparatus is able to electro spray beads and microparticles. Finally, we highlight the potential of the device for wound healing applications by demonstrating the possibility of electrospinning onto pig and human skins. Portable electrospinning devices are still at an early stage of development but they could soon become an attractive alternative to benchtop machines, in particular for uses that require mobility and a higher degree of flexibility, such as for wound healing applications.

[0008] An electrospinning device for producing a polymer dressing for protecting wound can be very useful in the field environment. The prior art documents disclose electrostatic portable devices operable only in case of grounding a surface of fiber deposition. Effective grounding of a specific patient's skin area is a complicated technical problem. Hence, there is a long-felt and unmet need to provide a handheld device for producing electrospun fiber dressing operable in case of natural grounding of the patient's body. Additionally, the aforesaid handheld device should be enabled to modify features of an obtained coating by means of reconfiguring an applied electrostatic field.

SUMMARY OF THE INVENTION

[0009] It is hence one object of the invention to disclose a handheld device for producing

electrospun fiber dressing. The aforesaid device comprises: (a) a housing configured to be handheld by a user; (b) a container accommodating at least one electrospinning medium; (c) at least one nozzle in fluid communication with said container; (d) a mechanism dispensing said medium from said container via said nozzle; (e) an auxiliary electrode surrounding said nozzle; and a power supply having providing electric potentials to said nozzle and said auxiliary electrode.

[0010] It is a core purpose of the invention to provide the housing comprising an electrically conductive portion configured to be gripped by said user during operation; said electrically conductive portion is connected to said power supply.

[0011] Another object of the invention is to disclose the auxiliary electrode which is displaceable along said nozzle.

[0012] A further object of the invention is to disclose the auxiliary electrode having a shape selected from a group consisting of: a circular barrel; an oval barrel, a sphere, an ellipsoid and any combination thereof.

[0013] A further object of the invention is to disclose the dispensing mechanism comprising a piston insertable into said container for out squeezing said electrospinning medium via said nozzle.

[0014] A further object of the invention is to disclose the container which is a carpule, a syringe, a barrel and any combination thereof.

[0015] A further object of the invention is to disclose the container and said nozzle integrated into a single element.

[0016] A further object of the invention is to disclose at least one of said container and said nozzle which is disposable.

[0017] A further object of the invention is to disclose the dispensing mechanism comprising a container bed configured for receiving said container when said electrospinning medium is squeezed from said container by said piston.

[0018] A further object of the invention is to disclose the container mechanically deformable such that said electrospinning medium is squeezed out from said container.

[0019] A further object of the invention is to disclose the container which is at least partially made of a material pierceable by said nozzle when exerted by said piston to establish a fluid communication between said container and nozzle.

[0020] A further object of the invention is to disclose the container comprising at least two sealed compartments successively pierceable by said nozzle to successively feed content of

said compartments to said nozzle.

[0021] A further object of the invention is to disclose the power supply is of a unipolar type.

[0022] A further object of the invention is to disclose the unipolar power supply is configured for providing a potential selected from the group consisting of a positive potential, a negative potential and alternatively positive and negative potentials.

[0023] A further object of the invention is to disclose the power supply provided with two spaced apart start buttons such that said device is gripped by both hands of an operator during operation thereof.

[0024] A further object of the invention is to disclose the device comprising at least two laser light sources emitting light beam meeting at a predetermined distance for producing an electrospun fiber dressing.

[0025] A further object of the invention is to disclose a method of producing electrospun fiber dressing. The aforesaid method comprises the steps of: (a) providing a handheld device for producing electrospun fiber dressing; said device comprising: (i) a housing configured to be handheld by a user; (ii) a container accommodating at least one electrospinning medium; (iii) at least one nozzle in fluid communication with said container; (iv) a mechanism dispensing said medium from said container via said nozzle; (v) an auxiliary electrode surrounding said nozzle; (vi) a power supply providing an electric potential to said nozzle and said auxiliary electrode; said housing comprises an electrically conductive portion configured to be gripped by said user during operation; said electrically conductive portion is connected to said power supply ; (b) gripping said device by a health care provider; (c) directing said device to location to be dressed; (d) applying electric potentials to said nozzle and said auxiliary electrode relative to said conductive portion; (e) electrospinning said medium.

[0026] A further object of the invention is to disclose the method comprising a step of displacing said auxiliary electrode along said nozzle to control a dimension and structure of an obtained fiber dressing.

[0027] A further object of the invention is to disclose the method comprising a step of outqueezing said electrospinning medium via said nozzle by said dispensing mechanism; said dispensing mechanism comprises a piston insertable into said container.

[0028] A further object of the invention is to disclose the method comprising a step of receiving said container into a container bed of said dispensing mechanism when said electrospinning medium is squeezed from said container by said piston.

[0029] A further object of the invention is to disclose the method comprising a step of mechanically deforming said container such that said electrospinning medium is outqueezed from said container.

[0030] A further object of the invention is to disclose the method comprising a step of piercing said container at least partially made of a material pierceable by said nozzle when exerted by said piston to establish a fluid communication between said container and nozzle.

[0031] A further object of the invention is to disclose the method comprising a step of successive piercing said container comprising at least two sealed compartments to successively feed content of said compartments to said nozzle.

[0032] A further object of the invention is to disclose the step of applying electric potentials is performed by a unipolar power supply.

[0033] A further object of the invention is to disclose the step of applying electric potentials comprising applying a potential selected from the group consisting of a positive potential, a negative potential and alternatively positive and negative potentials.

[0034] A further object of the invention is to disclose the method comprising a step of activating said power supply by two spaced-apart start buttons such that said device is gripped by both hands of an operator during operation thereof.

[0035] A further object of the invention is to disclose method comprising a step of positioning said device by means of at least two laser light sources emitting light beam meeting at a predetermined distance for producing an electrospun fiber dressing.

BRIEF DESCRIPTION OF THE DRAWINGS

[0036] In order to understand the invention and to see how it may be implemented in practice, a plurality of embodiments is adapted to now be described, by way of non-limiting example only, with reference to the accompanying drawings, in which

Fig. 1 is a schematic diagram of a handheld device for producing electrospun fiber dressing;

Fig. 2 is a cross-sectional view of a dispensing mechanism with a multi-compartmental container.

Fig. 3A is a cross-sectional view of an auxiliary electrode;

Figs. 3B - 3D are exemplary embodiments of an auxiliary electrode; and

Figs. 4A - 4C are exemplary graphs of output voltage generated by a unipolar power supply.

DETAILED DESCRIPTION OF THE INVENTION

[0037] The following description is provided, so as to enable any person skilled in the art to make use of said invention and sets forth the best modes contemplated by the inventor of carrying out this invention. Various modifications, however, are adapted to remain apparent to those skilled in the art, since the generic principles of the present invention have been defined specifically to provide a handheld device for producing electrospun fiber dressing and a method of using the same.

[0038] Electrospinning process is characterized by establishing a closed electric circuit including an air span between a high voltage electrode and a surface to be coated. For purpose of the present invention, it is implied that the surface to be coated is healthy or damaged skin, any kind of wounds having any location on the patient's body.

[0039] The electrospinning process is operable on condition that an electric current arises within the abovementioned air span. The electric current across the air span includes two main components:

1. a. a current originated from transferring charges carried by elemental fibers onto the surface to be coated; the elemental fibers are charged due to induction (contact) charging; charging brought about by collision with air ions within a corona discharge field;
2. b. a current of air ions which is relatively low, but can rise with increase in electric field intensity stemming from increase in applied voltage, shortening the air span and ignition/progressing of the corona discharge.

[0040] As mentioned above, the electrospinning device is operable if its electric circuit is closed. The closed electric circuit is provided by means of concurrent grounding a high voltage power supply and a surface to be coated (patient's body).

[0041] It should be appreciated that a total value of charge transfer current is in a range between 10^{-7} and 10^{-8} A and voltage of 30 kV. It follows thence that the resistance of the electric circuit should not exceed 10^{12} - 10^{11} Ω . It is believed that internal resistance of the human body is real and has a value of 500 - 700 Ω . Electric impedance of an external skin layer (epidermis) is characterized by real and capacitive components connected in parallel. Assuming that an area of the electrode located a handle of a hand-held electrospinning device (the handle is grippable by the user's hand) is several square cm, impedance value of operator-spinning device interconnection can be estimated as 10^{10} k Ω .

[0042] Thus, grounding resistance (ratio of voltage at the grounded electrospinning device to operational current) is sufficiently low to provide reliable operability for an electrospinning device not including direct electrical connection (by electric wire) to the surface to be covered as known in the art. According to the present invention, the electric circuit is closed via an

electrode located on the handle of the electrospinning device and bodies of the patient and the electrospinning device operator.

[0043] At an end of the needle electrode, polymer solution acquires an electric charge. Then, when a force of electrostatic repulsion is stronger than a surface tension force, particles of the semiliquid substance are originated.

[0044] Neoformed polymer fibers are charge carriers and move within the air span from the needle electrode to the surface to be coated under the electrostatic force F_C given by the following expression:

$$F_C = qE,$$

where q is an electric charge and E is electric field intensity.

[0045] Also, the gravity, inertial, aerodynamic and electrostatic repulsion forces should be taken into account. In the vicinity of the coated surface, there are forces which can be interpreted as Coulomb forces originated from fictive mirror charges located behind the coated surface.

[0046] Practically, electrostatic forces define dimension and configuration of the originated polymer jet pass and, consequently, geometry of the obtained electrospun coating.

[0047] Generally, change in distance between the needle electrode and the surface to be coated results in alteration of area of the obtained coating and its thickness and porosity in the case of constant time of electrospinning. For example, polymer fibers flying along a longer distance between the needle electrode and the surface to be coated lose more solvent by means of evaporation, and the resultant coating is characterized by higher density (lower porosity). In other words, area, thickness and porosity of the obtained coating can be modified according to specific needs by means of reconfiguring the applied electrostatic field. Additionally, the coating density depends on kinetic energy of the flying polymer fibers which is a function of applied voltage and the distance between the needle electrode and the surface to be coated.

[0048] An arrangement of the handheld electrospinning device having a needle high voltage electrode and a patient's body surface can be described as a needle-plane configuration which is characterized by the conic jet pass and coating profile is similar to the jet pass geometry. In case of constant flow rate of the polymer solution, change in a distance between the needle electrode and the patient's body surface results in change in coating thickness. Thicker coating characterized lower apparent density (higher porosity) corresponds to shorter distance between the needle electrode and patient's body surface. The shorter distance brings about higher rate of thickness growth and higher solvent content within the coating.

[0049] Thus, coating thickness can be controlled by means of changing the distance between the needle electrode and patient's body surface. It should be emphasized that a range of available thicknesses is limited by concomitant changes in coating density and fiber diameter.

[0050] It should be emphasized that an area of the obtained coating can be controlled also by means of introducing an auxiliary focusing electrode (deflector) into the electrostatic field in proximity of the needle electrode.

[0051] Reference is now made to Fig. 1, presenting a schematic diagram of a handheld device for producing electrospun fiber dressing 10. An electrical circuit comprises a battery energizing a high voltage power supply 70. One terminal of the high voltage power supply 70 is connected to by a wire 80 to a needle electrode 50 and an auxiliary electrode 60. According to one embodiment of the present invention, the electrodes 50 and 60 are at equal electric potentials and the resultant electrostatic field moving the polymer fiber from the needle electrode 50 to a surface to be coated 160 is characterized as a superposition of electric fields generated by the needle and auxiliary electrodes 50 and 60, respectively. Another terminal of the power supply 70 is connected to a conductive portion 110 of a device handle 120. The conductive portion 110 is configured to be gripped by a hand of an operator (not shown). The impedance value corresponding operator-spinning device interconnection was estimated above. A mechanical arrangement comprises a housing 100 having at least one portion 120 configured to be handheld by a user; a container 40 accommodating at least one electrospinning medium; a nozzle (needle electrode) 50 in fluid communication with the container 40; a motor 20 and a piston 30 driven by the motor 20. The piston 30 exerts the container such that the accommodated electrospinning medium is squeezed out the nozzle (needle electrode) 50.

[0052] According to the present invention, an exemplary embodiment of the auxiliary electrode 60 has a toroid shape; thereat the needle electrode 50 is coaxially nested within the toroid auxiliary electrode 60. Any position of the needle electrode 50 relative to the auxiliary electrode 60 including a projecting position and a recessed position and mutual electrode movability are in the scope of the present invention.

[0053] The aforesaid needle electrode 50 and auxiliary electrode 60 are made of a conductive material. An electric field configuration created by the electrodes 50 and 60 depends on their relative position (projecting/ recessed position) and a circumferential gap between the needle electrode 50 and an inner surface of the auxiliary electrode 60.

[0054] A deeper position of the needle electrode 50 within the auxiliary electrode 60 and a small circumferential gap result in reduction in an area of the obtained coating.

[0055] To prevent an operator from electric shock, device 10 is provided with two spaced apart start buttons 130. An operator can actuate device 10 only if he/she grips device by both hands. Specifically, one button 130 is located on a handle 120 and another on front surface under auxiliary electrode 60.

[0056] It is known in the art that properties of a produced dressing depend on a distance between a needle electrode 50 and an object 160 to be dressed (distance between electrodes). Device 10 is provided with two laser light sources 140 which assist in positioning

device 10 relative to object 160. Laser beams 150 are arranged such that their point of intersection is at a predetermined distance of forming an optimal dressing by flow of charged polymer fibers 55. Thus, positioning device 10 constitutes placing the intersection point onto a surface of object 160.

[0057] Reference is now made to Fig. 2, presenting a dispensing mechanism with an exemplar container 40a comprising three compartments 47. The container is disposed into container bed 45. Needle 49 is protruded into barrel such that, when container 40a is pressed by piston 30 against container bed 45, compartments 47 are successively pierced by nozzle 50 and content of aforesaid compartments is fed to needle electrode 50 via needle 49. Use of compartmented container 40a provides an opportunity of producing multilayer dressings without replacement of container 40 during operation of device 10. A device comprising a plurality of nozzles fed by one container is also in the scope of the invention. The device of the present invention can include also a plurality nozzles individually connected to containers accommodating materials to be electrospun.

[0058] Reference is now made to Fig. 3A, presenting a cross-sectional view of a needle electrode 50 - auxiliary electrode 60 arrangement. A collar member 75 is disposed between the needle electrode 50 and auxiliary electrode 60 and provides mutual coaxial movability of the electrodes 50 and 60.

[0059] Reference is now made to Figs 3B-3D, presenting alternative embodiments of the auxiliary electrode 60.

[0060] Polymer fibers originated during electrospinning process are characterized by high electric resistance of 10^{-12} - 10^{-15} Ω ·cm. On the one hand, high electric resistance of the polymer fibers enables containment of the fibers on a surface to be coated by means of Coulombian forces. Initially, the surface to be coated can be considered as a grounded surface charged opposite to a charge of the needle/auxiliary electrode. Then, especially in case of a low conductive coating substrate, the polymer fibers deposited on the surface to be coated form a surface charge. In other words, like-charge polymer fibers repel each other by the Coulombian forces.

[0061] Coating a surface having a deep profile is also attributed to a complicated technical problem. The patient's body also can be characterized as a combination of bulged and recessed areas. It should be appreciated that motion path of the charged fibers is according to electrostatic lines of force closing on projecting parts. The recessed areas can be interpreted as potential wells where the charged polymer fibers cannot pass through. Thus, the recess areas remain not coated.

[0062] More uniform coating can be provided by a pulse mode of the electrospinning process. Specifically, the high voltage power supply applies a train of alternative (negative and positive) potentials to needle/auxiliary electrodes arrangement at frequency ranging between 0.1 and 10 Hz. In this case, the motion path of the charged fibers is defined not only by electrode

potentials, but also by interaction between charges carried by the coating which has been already formed and the fibers flying across the air gap between the electrodes arrangement and the coating. The pulse mode conveys polymer fibers to the areas which were inaccessible for the conventional electrospinning technology due to coating surface charge. In the case of the pulse mode, elemental coating layers obtained during single voltage pulses electrically neutralize each other. As result, the coating surface becomes electrically neutral.

[0063] Reference is now made to Figs 4A-4B, presenting graphs of exemplar trains of electric voltage pulses applied to the electrode arrangement.

[0064] Fig. 4A shows a preferable form of an output voltage generated by the unipolar power supply. The output voltage is characterized by a train of square voltage pulses. The polymer fibers are accelerated in the electrostatic field and continue flying to the surface to be coated due to kinetic energy which has been gained before in the electrostatic field. Inertial motion of the flying polymer fibers with no electrostatic field can be interpreted as motion of a particle within a potential well, when the particle achieves a well bottom.

[0065] An achievable form of the output voltage generated by the unipolar power supply is presented in Fig. 4B. Square voltage pulses are smoothed due to reactive impedance of power supply circuitry.

[0066] According to one embodiment of the present invention, a coating of increased thickness can be obtained by means of electrospinning process with a form of the output voltage presented in Fig. 4C. The charge which is accumulated on the surface to be coated in case of the continuous unipolar electrospinning process is neutralized by means of alternating polarity of the voltage applied to needle and auxiliary electrodes.

REFERENCES CITED IN THE DESCRIPTION

This list of references cited by the applicant is for the reader's convenience only. It does not form part of the European patent document. Even though great care has been taken in compiling the references, errors or omissions cannot be excluded and the EPO disclaims all liability in this regard.

Patent documents cited in the description

- [WO2010059127A](#) **[0003]**
- [US6753454B](#) **[0004]**
- [US7794219B](#) **[0005]**

Non-patent literature cited in the description

- **SHI-CONG XU et al.** *Nanoscale*, 2015, vol. 7, 12351- [\[0006\]](#)
- **PIERRE-ALEXIS MOUTHUY** *Biotechnol Lett*, 2015, vol. 37, 1107-1116 [\[0007\]](#)

Patentkrav

1. Håndholdt anordning (10) til at fremstille elektrospundne fiberforbindinger; idet anordningen omfatter:
 - 5 a. et hus (100), der har mindst én del (120), der er konfigureret til, at en bruger holder den i hånden;
 - b. en beholder (40), hvor der er plads til mindst ét elektrospundet medie;
 - c. mindst én dyse (50), der er i væskedommunikation med
10 beholderen (40);
 - d. en mekanisme, der dispenserer mediet fra beholderen (40) via dysen (50);
 - e. en hjælpeelektrode (60), der omgiver dysen (50);
 - f. en strømforsyning (70), der tilvejebringer elektrisk
15 spænding til dysen (50) og hjælpeelektroden (60);hvor huset (100) omfatter en elektrisk ledende del (110), der er konfigureret til, at brugeren tager fat i den under anvendelse; idet den elektrisk ledende del (110) er forbundet til strømforsyningen (70).
20
2. Anordningen ifølge krav 1, hvor mindst ét af følgende er sandt:
 - a. hjælpeelektroden kan forskydes langs dysen;
 - b. hjælpeelektroden har en form, der er udvalgt fra en gruppe,
25 som består af: en rund tromle; en oval tromle, en kugle, en ellipsoide og enhver kombination af disse;
 - c. dispenseringsmekanismen omfatter et stempel, der bruger beholderen til at presse det elektrospundne medie ud via dysen;
 - 30 d. beholderen er udvalgt fra gruppen, der består af en carpule, en sprøjte, en tromle og enhver kombination af disse.
3. Anordningen ifølge krav 1, hvor mindst ét af følgende er sandt:
 - 35 a. beholderen og dysen er bygget sammen til ét enkelt element;
 - b. mindst én af beholderen og dysen er til engangsbrug.
4. Anordningen ifølge krav 1, hvor dispenseringsmekanismen

tilvejebringer en beholderbund, der er konfigureret til, at beholderen kan monteres der, når elektrospinningmediet presses ud af beholderen ved hjælp af stemplet.

5 5. Anordningen ifølge krav 4, hvor beholderen kan deformeres mekanisk, således at elektrospinningmediet presses ud af beholderen.

6. Anordningen ifølge krav 5, hvor beholderen mindst delvist
10 er lavet af et materiale, der kan perforeres af dysen, når det påføres af stemplet for at etablere en væskekommunikation mellem beholderen og dysen.

7. Anordningen ifølge krav 6, hvor beholderen omfatter
15 mindst to forseglede rum, der kan perforeres efter hinanden af dysen for at føre indhold fra rummene til dysen.

8. Anordningen ifølge krav 1, hvor mindst ét af følgende er sandt:

20 a. strømforsyningen er af en enpolet type;

b. strømforsyningen er konfigureret til at tilvejebringe en spænding, der er udvalgt fra gruppen, der består af en positiv spænding, en negativ spænding og skiftevis positive og negative spændinger;

25 c. strømforsyningen er tilvejebragt med to startknapper med mellemrum imellem, således at der tages fat i anordningen med begge en operatørs hænder under betjening af denne.

9. Anordningen ifølge krav 1, der omfatter et middel til
30 anbringelse af anordningen i forhold til en placering af en elektrospundet fiberforbinding, der skal fremstilles.

10. Anordningen ifølge krav 9, hvor midlet til anbringelse omfatter mindst to laserlyskilder, der udsender en lysstråle,
35 som mødes ved en forudbestemt afstand for at fremstille en elektrospundet fiberforbinding.

11. Fremgangsmåde til at fremstille elektrospundet

fiberforbinding; idet fremgangsmåden omfatter følgende trin:

a. tilvejebringelse af en håndholdt anordning (10) til at fremstille elektrospundne fiberforbindinger; idet anordningen omfatter:

- 5 i. et hus (100), der er konfigureret til, at en bruger holder den i hånden;
- ii. en beholder (40), hvor der er plads til mindst ét elektrospundet medie;
- 10 iii. mindst én dyse (50), der er i væskekommunikation med beholderen (40);
- iv. en mekanisme, der dispenserer mediet fra beholderen (40) via dysen (50);
- v. en hjælpeelektrode (60), der omgiver dysen (50);
- 15 vi. en strømforsyning (70), der tilvejebringer elektrisk spænding til dysen (50) og hjælpeelektroden (60); idet huset (100) omfatter en elektrisk ledende del (110), der er konfigureret til, at brugeren tager fat i den under anvendelse; idet den elektrisk ledende del (110) er forbundet til strømforsyningen (70);
- 20 b. at en sundhedsmedarbejder griber fat i anordningen (10);
- c. at anordningen (10) føres hen til det sted, der skal forbindes;
- d. at der påføres elektrisk spænding på dysen (50) og hjælpeelektroden (60) i forhold til den ledende del;
- 25 e. elektrospinning af mediet.

12. Fremgangsmåden ifølge krav 11, hvor mindst ét af følgende er sandt:

- 30 a. fremgangsmåden omfatter et trin, hvor hjælpeelektroden forskydes langs dysen for at kontrollere en dimension og struktur af en opnået fiberforbinding;
- b. hjælpeelektroden har en form, der er udvalgt fra en gruppe, som består af: en rund tromle; en oval tromle, en kugle, en ellipsoide og enhver kombination af disse;
- 35 c. fremgangsmåden omfatter et trin, hvor elektrospinningmediet presses ud via dysen med dispenseringsmekanismen; idet dispenseringsmekanismen omfatter et stempel, der kan indføres i beholderen.

13. Fremgangsmåden ifølge krav 11, der omfatter et trin, hvor beholderen monteres i en beholderbund på dispenseringsmekanismen, når elektrospinningmediet presses ud af beholderen med stemplet.

5

14. Fremgangsmåden ifølge krav 13, der omfatter et trin, hvor beholderen deformeres mekanisk, således at elektrospinningmediet presses ud af beholderen.

10

15. Fremgangsmåden ifølge krav 14, der omfatter et trin, hvor beholderen, der mindst delvist er lavet af et materiale, der kan perforeres af dysen, perforeres, når det påføres af stemplet for at etablere en væskekommunikation mellem beholderen og dysen.

15

16. Fremgangsmåden ifølge krav 15, der omfatter et trin, hvor beholderen perforeres i rækkefølge, idet den omfatter mindst to forseglede rum for at føre indhold fra rummene til dysen.

20

17. Fremgangsmåden ifølge krav 11, hvor mindst ét af følgende er sandt:

a. trinnet, hvor der påføres elektrisk spænding, udføres af en enpolet strømforsyning;

25 b. trinnet, hvor der påføres elektriske spændinger, omfatter påføring af en spænding, der er udvalgt fra gruppen, der består af en positiv spænding, en negativ spænding og skiftevis positive og negative spændinger;

30 c. fremgangsmåden omfatter et trin, hvor strømforsyningen aktiveres med to startknapper med mellemrum imellem, således at der tages fat i anordningen med begge en operatørs hænder under betjening af denne.

30

18. Fremgangsmåden ifølge krav 11, hvor mindst ét af følgende er sandt:

35

a. fremgangsmåden omfatter et trin, hvor anordningen anbringes i forhold til en placering af en elektrospundet fiberforbinding, der skal fremstilles;

b. trinnet, hvor anordningen anbringes, udføres ved hjælp af mindst to laserlyskilder, der udsender en lysstråle, som mødes ved en forudbestemt afstand for at fremstille en elektrospundet fiberforbinding.

DRAWINGS

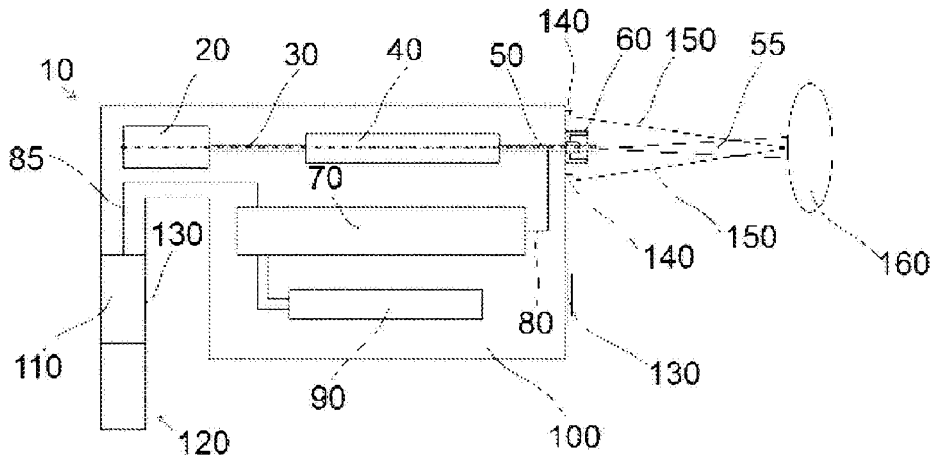

Fig. 1

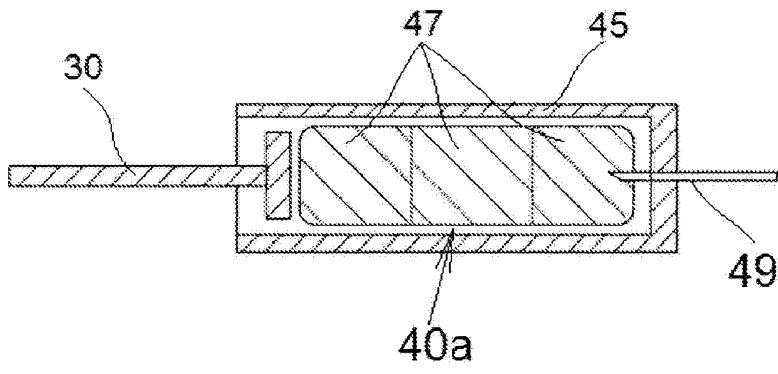

Fig. 2

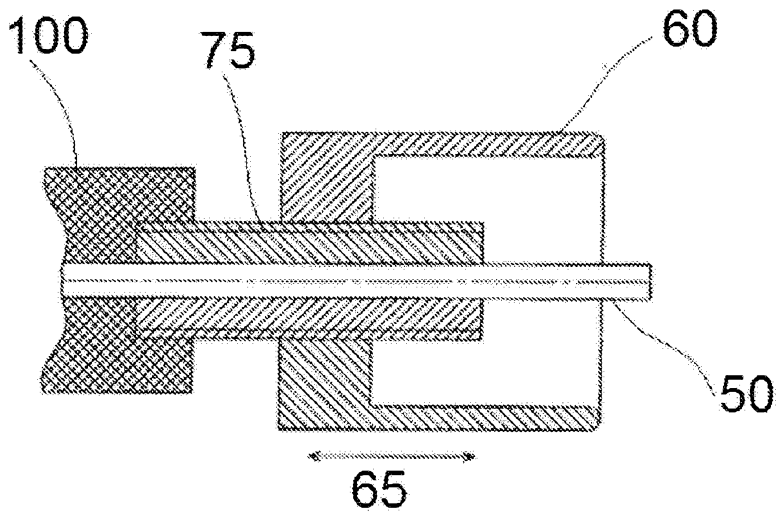

Fig. 3A

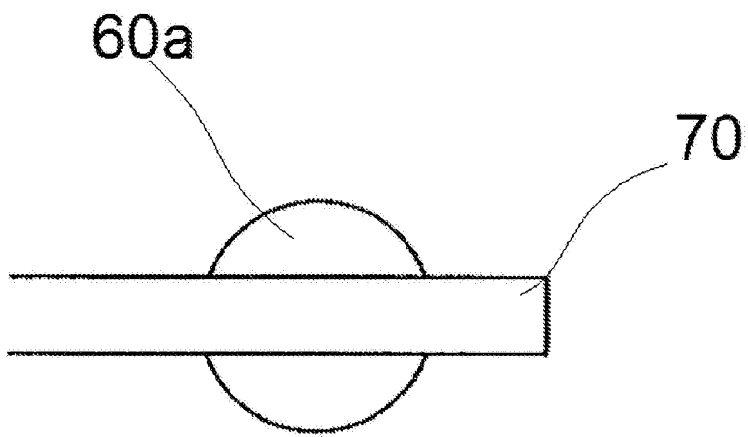

Fig. 3B

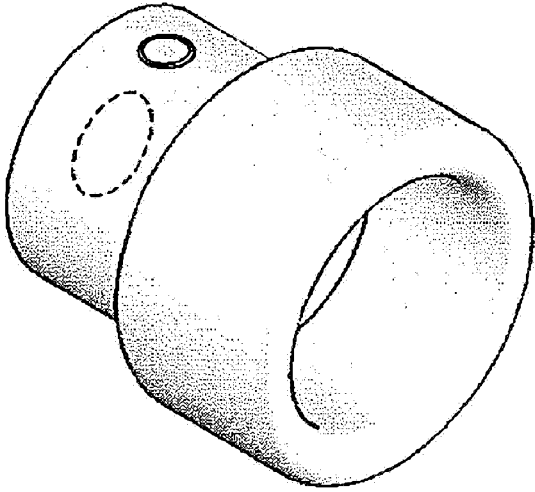

Fig. 3C

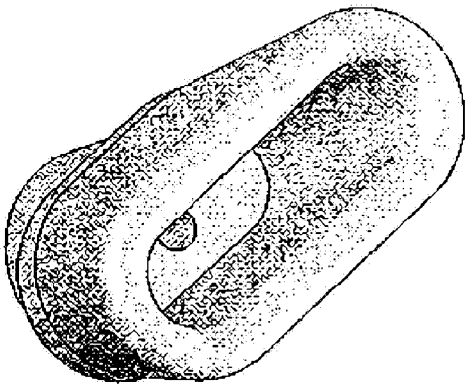

Fig. 3D

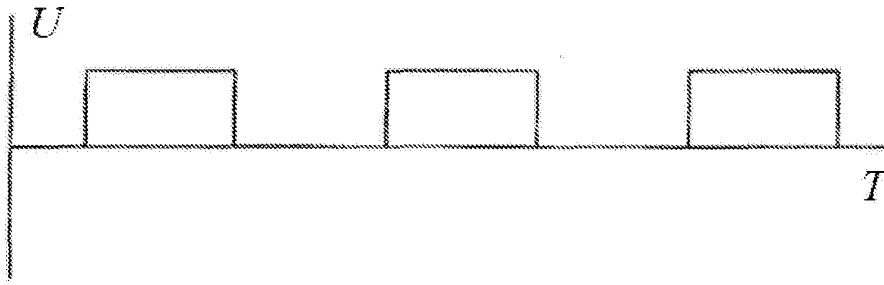

Fig. 4A

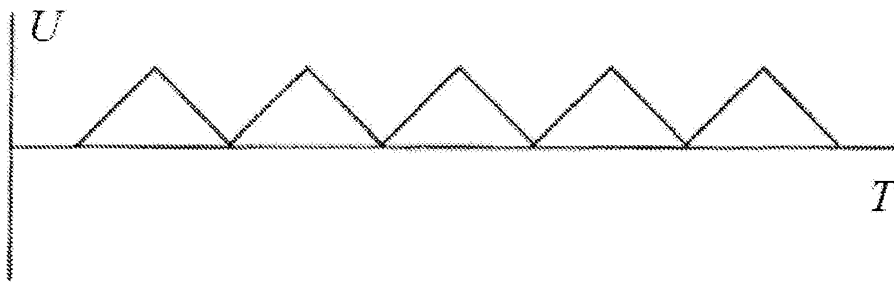

Fig. 4B

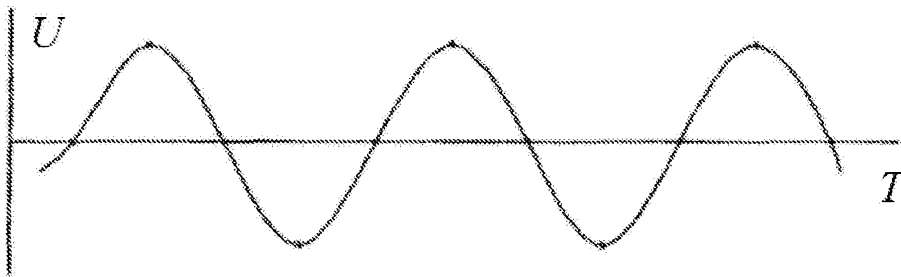

Fig. 4C