



(12) **EUROPEAN PATENT APPLICATION**

(43) Date of publication:
08.06.2005 Bulletin 2005/23

(51) Int Cl.7: **F24J 3/00, F24D 7/00,
F24D 11/00**

(21) Application number: **03104530.5**

(22) Date of filing: **03.12.2003**

(84) Designated Contracting States:
**AT BE BG CH CY CZ DE DK EE ES FI FR GB GR
HU IE IT LI LU MC NL PT RO SE SI SK TR**
Designated Extension States:
AL LT LV MK

(72) Inventors:
• **Sadikovic, Samir
71000, Sarajevo (BA)**
• **Sadikovic, Ahmet
33102, Paderborn (DE)**

(71) Applicant: **Optos Optimale Oszillationstechnik
GmbH
34414 Warburg (DE)**

(74) Representative: **Vernout, Robert et al
Arnold & Siedsma,
Sweelinckplein 1
2517 GK Den Haag (NL)**

(54) **System and method for heating an object**

(57) System for heating an object by a heated liquid, comprising a container for holding an amount of liquid, and a circulation conduit having an inlet and an outlet both connected to said container, the conduit compris-

ing a pump for pumping the liquid through said conduit, wherein the conduit further comprises a kinetic generator comprising means for generating a non-axial movement in the liquid being pumped through the conduit in order to raise the temperature of the liquid.

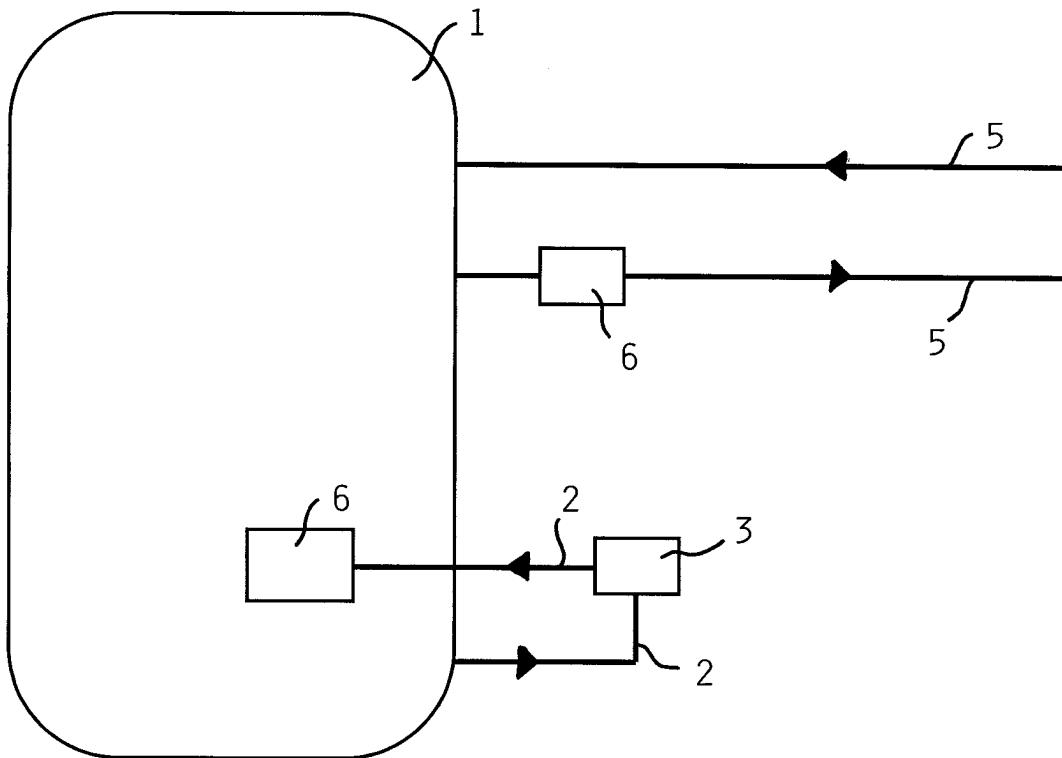

FIG. 1

Description

[0001] The invention relates to a system for heating an object, for instance a room, by a heated liquid, comprising a container for holding an amount of liquid, and a circulation conduit having an inlet and an outlet both connected to said container, the conduit comprising a pump for pumping the liquid through said conduit.

[0002] Such systems are well known in the art. The known systems comprise a container which is usually referred to as a boiler, wherein the liquid, typically water, is stored which is heated by means of burning gas or oil, or by electric or solar heating devices for instance. The heated water can be circulated by the pump through a well known central heating circuit containing radiators, or alternatively through a floor heating conduit.

[0003] These known heating systems thus require means to transfer the heat from a heat source to the circulating liquid. The invention aims at a system which is cheaper to build, install and/or maintain, and/or which is more energy effective in use than previous systems.

[0004] To that end according to the invention the conduit further comprises a kinetic generator comprising means for generating a non-axial movement in the liquid being pumped through the conduit in order to raise the temperature of the liquid. The term "non-axial movement" in this respect means a movement having a component diverting from the axis of the conduit. Said movement can be a micro-level movement or a larger scale movement in the liquid, as will be explained below.

[0005] In a heating system, heating the liquid by causing intense local movement within the liquid has proven to be a very efficient way to raise its temperature, in particular in heating systems wherein the temperature difference needs only to be limited. The amount of the temperature rise depends on the amount of internal movement applied to the liquid, and also on the sort of liquid that is used. Therefore many configurations of the system are possible depending of the intended use of the system. Typically the temperature of the liquid is raised by a few centigrades in this manner. Preferably the kinetic generator is a static object that extends within the axial flow of the liquid in the conduit resulting from the pump. The energy to heat the liquid can thus entirely be supplied by said pump.

[0006] The heating system of the invention can advantageously be used for central heating, but also for heating greenhouses, defrosting roads and bridges, supplying warm water to swimming pools, etcetera.

[0007] Although the temperature of liquid in the system can be raised substantially by recycling the liquid many times, it may be more suitable to use conventional heating means to bring the liquid in the system to a desired temperature level initially. The pump then must have enough capacity to compensate for the heat that is radiated to the object to be heated, such as a room.

[0008] In a first preferred embodiment the kinetic generator comprises deflection means for converting the

axial flow of the liquid through the conduit into a whirling substantially helical flow. Preferably in this embodiment the kinetic generator is connected to the container through a pipe having a length between 0.1 and 1 m, in which the whirling flow will be maintained before it flows into the container, during which time the temperature of the liquid will rise. Preferably said pipe has a diameter between 3 and 10 cm, more preferably between 4 and 7 cm.

[0009] In a second preferred embodiment the kinetic generator comprises a vibrating element which can vibrate at a high frequency, said vibrating movement being transferred to the liquid flow. Preferably the vibration of the vibrating element is generated by the liquid flow, in a manner which is comparable to the vibration of an organ pipe or a flute which is generated by air flowing through it. Thereto a vibration element is placed in the liquid flow, which element has a protruding lip extending in the upstream direction. Preferably in this embodiment the kinetic generator is located near the outlet of the conduit into the container.

[0010] Preferably the pump has a capacity so as to generate a pressure of at least 2 bar, more preferably at least 4 bar, even more preferably at least 5 bar in said conduit, and preferably a flow of at least 3000 l per hour, more preferably between 3800 and 4500 l per hour. The heat generated by the pump itself is preferably used also to heat the liquid.

[0011] Preferably the container is filled with a liquid having a specific weight of at least 1.1 kg/l, more preferably between 1.15 and 1.30 kg/l at 20°C. Although the system will work when plain water is used, having a specific weight of 1 kg/l, it has been proven more effective to use a liquid having a higher specific weight. Such specific weight can for instance be achieved by using oil, polyvalent alcohols, or an aqueous solution comprising at least 15%, more preferably at least 30% by weight of a metallic salt. Good test results have been achieved by using MgCl₂ and/or MgCl₂·6H₂O (crystal water) as main component of the salt, for instance with an aqueous solution containing 23.5% MgCl₂, 25.4% MgCl₂·6H₂O, 0.38% MgSO₄, 0.25% CaSO₄, 0.15% KCl and 0.35% NaCl by weight.

[0012] The system is particularly useful and effective when the means for transferring the heat of the fluid in said container to a room is a floor heating system. In a floor heating system the temperature of the circulating liquid should be not too high, for instance 30°C, and the heating method of the invention is particularly suitable for low temperature gradients. Furthermore, by using the mentioned preferred liquids and a suitably long and narrow circuit, enough heat may be generated without the need for a kinetic generator element in the conduit. This may constitute a separate invention.

[0013] Although it would be possible to place the kinetic generator in the floor heating conduit, preferably the kinetic generator is part of a separate (short) first circulation conduit, and the container is further connect-

ed to a second pump for pumping said fluid through a second conduit, said second conduit being a part of a conventionally controlled floor heating system. In this way it is possible to circulate the liquid through the kinetic generator as many times as necessary to obtain or maintain a required liquid temperature in the container, independent from the circulation speed in the floor heating system. The time necessary to heat the liquid to a required temperature can be regulated by a regulating device well known in the art.

[0014] The container preferably has a capacity between 300 and 3.000 l. If a large container is used, the system can make use of cheap electricity costs during the night, if available, and store the heat in the liquid for use during the day. It may in that case be advantageous to use a liquid containing polyvalent alcohols which have a good heat storing capacity.

[0015] Alternatively the system comprises a heat exchanger and a condenser system for cooling a room, such as in an air conditioning system.

[0016] The invention also relates to a method for heating an object by a heated fluid, wherein fluid is pumped from a container for holding an amount of said fluid through a circulation conduit and back into said container, wherein a non-axial movement is generated in the fluid being pumped through the conduit by kinetic generating means in order to heat the fluid.

[0017] The invention will be illustrated by means of the figures, wherein:

Figure 1 is a schematic view of a heating system; and

Figure 2 is a schematic longitudinal section of a kinetic generator.

[0018] According to Figure 1 a heating system comprises a container 1 wherein an amount of warm liquid is stored. In this embodiment the container has a volume of 300 l, and the liquid is a 1:1 by weight aqueous solution of:

47% MgCl₂
 0.75% MgSO₄
 0.5% CaSO₄
 0.3% KCl
 0.7% NaCl
 50.75% MgCl₂-6H₂O (crystal water)

[0019] The container 1 is connected to a first circuit 2 through which the liquid is pumped at high speed by a pump 3. The width of the conduits of circuit 2 is approximately 5 cm. The capacity of the pump is approximately 4000 l per hour, at a working pressure of 4 bar. The outlet of circuit 2 is located within the container 1, at some distance from the wall of the container 1, and is provided with a kinetic generator 4 for heating the liquid, which will be explained in more detail below. The pump

3 is controlled by a well known temperature control device, which will switch the pump 3 off as soon as the temperature of the liquid reaches an adjustable maximum.

[0020] The container 1 is further connected to a second circuit 5, comprising a second pump 6. This second circuit 5 is for instance a conventional floor heating circuit, or any other conventional central heating circuit, and comprises well known control devices (such as a thermostat) for regulating the temperature of the room to be heated. The materials used in the circuits are chosen such that they are resistant against the salt solution inside the system.

[0021] According to figure 2 the kinetic generator 4 comprises a cylindrical head 7 with an axial inlet channel 8, and two laterally extending outlets 9. From the end wall 10 of the head 7 extends a plate shaped lip 11 having a sharp edge 12 pointing upstream, which lip is dimensioned such that if the liquid flows against it the lip will vibrate at a high frequency, which will cause a raise in the temperature of the liquid. By circulating the liquid content of the container 1 through the circuit 2 a desired temperature raise of the liquid can be obtained.

Claims

1. System for heating an object by a heated liquid, comprising a container (1) for holding an amount of liquid, and a circulation conduit (2) having an inlet and an outlet both connected to said container, the conduit comprising a pump (3) for pumping the liquid through said conduit (2), **characterized in that** the conduit (2) further comprises a kinetic generator (4) comprising means (11) for generating a non-axial movement in the liquid being pumped through the conduit (2) in order to raise the temperature of the liquid.
2. System according to claim 1, wherein the kinetic generator (4) comprises a static object (11) that extends within the axial flow of the liquid through the conduit (2) resulting from the pump (3).
3. System according to claim 1 or 2, wherein the kinetic generator (4) comprises deflection means for converting the axial flow of the liquid through the conduit (2) to a whirling substantially helical flow.
4. System according to claim 3, wherein the kinetic generator (4) is connected to the container (1) through a pipe having a length between 0.1 and 1 m.
5. System according to claim 1 or 2, wherein the kinetic generator (4) comprises a vibrating element (11) which can vibrate at a high frequency, said vibrating movement being transferred to the liquid flow.

6. System according to claim 5, wherein the vibration of the vibrating element (11) is generated by the liquid flow.
7. System according to any of the preceding claims 1 - 6, wherein the pump (4) has a capacity so as to generate a pressure of at least 2 bar, preferably at least 4 bar, more preferably at least 5 bar in said conduit (2). 5
10
8. System according to any of the preceding claims 1 - 7, wherein the container (1) is filled with a liquid having a weight of at least 1.1 kg/l, preferably between 1.15 and 1.30 kg/l at 20°C. 15
9. System according to any of the preceding claims 1 - 8, wherein the container (1) is filled with an aqueous solution comprising at least 15%, preferably at least 30% by weight of a metallic salt. 20
10. System according to claim 9, wherein said aqueous solution comprises $MgCl_2$ and/or $MgCl_2 \cdot 6H_2O$.
11. System according to any of the preceding claims 1 - 10, wherein the system comprises means (5, 6) for transferring the heat of the fluid in said container (1) to a room, preferably by means of a floor heating system. 25
12. System according to any of the preceding claims 1 - 11, wherein the container (1) is connected to a second pump (6) for pumping said fluid through a second conduit (5), said second conduit being a part of a floor heating system. 30
35
13. System according to any of the preceding claims 1 - 12, wherein the system comprises a heat exchanger and a condenser system for cooling a room. 40
14. Method for heating an object by a heated fluid, wherein fluid is pumped from a container (1) for holding an amount of said fluid through a circulation conduit (2) and back into said container (1), **characterized in that** a non-axial movement is generated in the fluid being pumped through the conduit (2) by kinetic generating means (4) in order to heat the fluid. 45
15. Method according to claim 14, wherein said movement is a whirl. 50
16. Method according to claim 14, wherein said movement is a high frequency vibration. 55

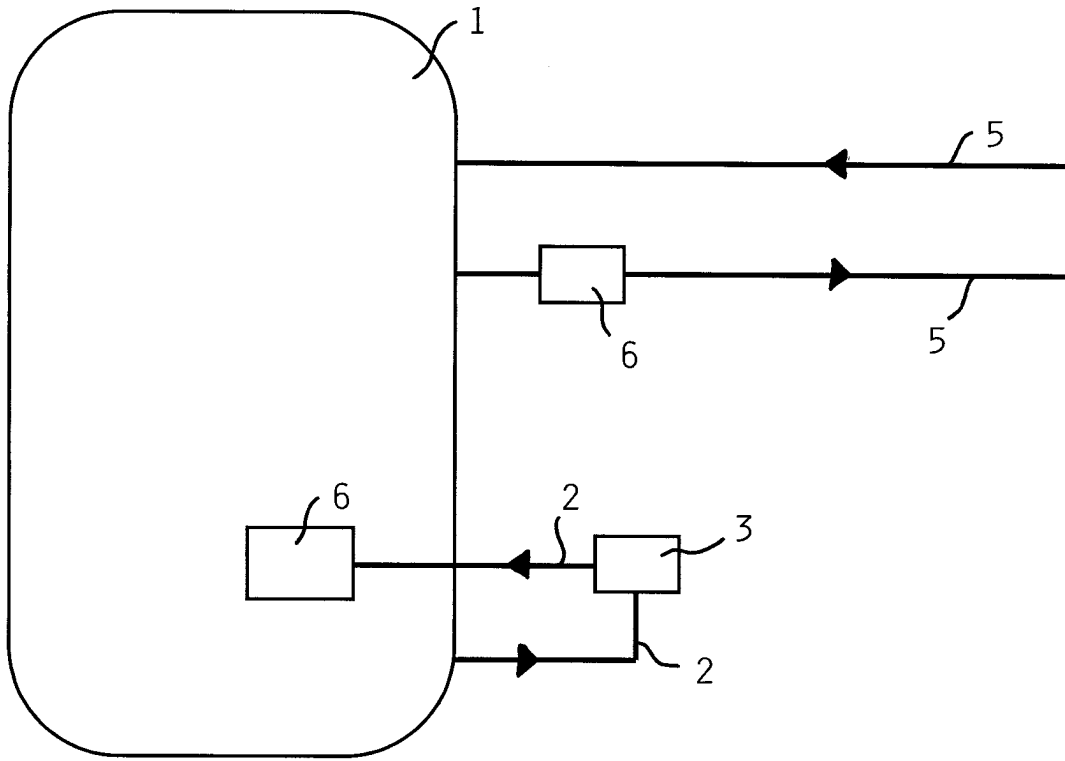

FIG. 1

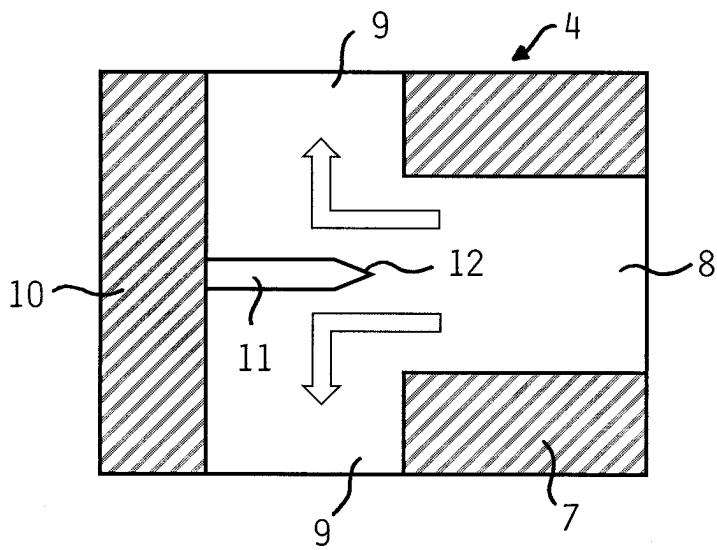

FIG. 2



European Patent
Office

EUROPEAN SEARCH REPORT

Application Number
EP 03 10 4530

DOCUMENTS CONSIDERED TO BE RELEVANT			
Category	Citation of document with indication, where appropriate, of relevant passages	Relevant to claim	CLASSIFICATION OF THE APPLICATION (Int.Cl.7)
X	DE 29 48 244 A (HOELZEMANN RUEDIGER) 4 June 1981 (1981-06-04)	1-5,7, 11,14,15	F24J3/00 F24D7/00
Y	* page 5, paragraph 2 - page 6, paragraph 3; figure 1 *	12,13	F24D11/00

X	US 4 489 678 A (SEHLIN LARS E ET AL) 25 December 1984 (1984-12-25)	1,2,14	
A	* the whole document *	11,12	

X	US 4 344 567 A (HORNE C JAMES ET AL) 17 August 1982 (1982-08-17)	1,2,14	
A	* the whole document *	11,12	

X	EP 0 833 114 A (ADVANCED MOLECULAR TECHNOLOGIE) 1 April 1998 (1998-04-01)	14-16	
A	* page 1, line 28 - line 39 * * page 6, line 15 - line 22 * * tables 1,2 * * figure 1 *	5,6	

Y	DE 295 15 138 U (HY TEC GMBH) 30 January 1997 (1997-01-30)	12	TECHNICAL FIELDS SEARCHED (Int.Cl.7)
	* page 10, paragraph 6 - page 12, paragraph 1; figure 1 *		F24J F24D

Y	EP 0 855 300 A (TOYODA AUTOMATIC LOOM WORKS ;DENSO CORP (JP)) 29 July 1998 (1998-07-29)	13	
	* figure 1; example 1 *		

The present search report has been drawn up for all claims			
Place of search MUNICH		Date of completion of the search 22 April 2004	Examiner Arndt, M
CATEGORY OF CITED DOCUMENTS X : particularly relevant if taken alone Y : particularly relevant if combined with another document of the same category A : technological background O : non-written disclosure P : intermediate document		T : theory or principle underlying the invention E : earlier patent document, but published on, or after the filing date D : document cited in the application L : document cited for other reasons & : member of the same patent family, corresponding document	

1

EPO FORM 1503 03.82 (P04C01)

**ANNEX TO THE EUROPEAN SEARCH REPORT
ON EUROPEAN PATENT APPLICATION NO.**

EP 03 10 4530

This annex lists the patent family members relating to the patent documents cited in the above-mentioned European search report. The members are as contained in the European Patent Office EDP file on the European Patent Office is in no way liable for these particulars which are merely given for the purpose of information.

22-04-2004

Patent document cited in search report		Publication date	Patent family member(s)	Publication date
DE 2948244	A	04-06-1981	DE 2948244 A1	04-06-1981
US 4489678	A	25-12-1984	EP 0093100 A2	02-11-1983
			JP 58190659 A	07-11-1983
			SE 8202474 A	21-10-1983
US 4344567	A	17-08-1982	NONE	
EP 0833114	A	01-04-1998	WO 9633374 A1	24-10-1996
			EP 0833114 A1	01-04-1998
			JP 11503818 T	30-03-1999
			RU 2150055 C1	27-05-2000
			US 6227193 B1	08-05-2001
			US 6016798 A	25-01-2000
DE 29515138	U	30-01-1997	DE 29515138 U1	30-01-1997
EP 0855300	A	29-07-1998	JP 10203143 A	04-08-1998
			CA 2226162 A1	28-07-1998
			DE 69805214 D1	13-06-2002
			DE 69805214 T2	29-08-2002
			EP 0855300 A2	29-07-1998
			US 5897056 A	27-04-1999