

REPUBLIC OF SOUTH AFRICA  
PATENTS ACT, 1978

(To be lodged in duplicate)

## PUBLICATION PARTICULARS AND ABSTRACT

(Section 32(3)(a) - Regulations 22(1)(g) and 31)

REFERENCE: P33200ZA00

OFFICIAL APPLICATION NO.		LOGGING DATE	ACCEPTANCE DATE	
21	01	2006/05	22/23	21 June 2006
			43	2007-09-15

INTERNATIONAL CLASSIFICATION		NOT FOR PUBLICATION
51	G21C	CLASSIFIED BY:

FULL NAME(S) OF APPLICANT(S)	
71	AREVA NP

FULL NAME(S) OF INVENTORS	
72	LABARRIERE, Eric BEATI, Angelo BONNAMOUR, Michel

EARLIEST PRIORITY CLAIMED	COUNTRY	NUMBER	DATE
33	FR	31	22 December 2003
			32

NOTE: The country must be indicated by its International Abbreviation - see Schedule 4 of the Regulations

TITLE OF INVENTION	
54	FUEL ASSEMBLY END CAP COMPRISING A COOLANT-FLOW - ORIENTING NOZZLE AND CORRESPONDING ASSEMBLY

57	ABSTRACT (NOT MORE THAN 150 WORDS)	NUMBER OF PAGES
		30

FOR ABSTRACT SEE THE NEXT SHEET

(12) DEMANDE INTERNATIONALE PUBLIÉE EN VERTU DU TRAITÉ DE COOPÉRATION EN MATIÈRE DE BREVETS (PCT)

(19) Organisation Mondiale de la Propriété Intellectuelle  
Bureau international



(43) Date de la publication internationale  
21 juillet 2005 (21.07.2005)

PCT

(10) Numéro de publication internationale  
WO 2005/066976 A2

- (51) Classification internationale des brevets: G21C 3/33
- (21) Numéro de la demande internationale : PC/FR2004/003299
- (22) Date de dépôt international : 17 décembre 2004 (17.12.2004)
- (25) Langue de dépôt : français
- (26) Langue de publication : français
- (30) Données relatives à la priorité : 0315183 22 décembre 2003 (22.12.2003) FR
- (71) Déposant (pour tous les États désignés sauf US) : FRAM-ATOME ANP [FR/FR], Tour AREVA, 1, place de la Coupole, F-92400 COURBEVOIE (FR)
- (72) Inventeurs; et
- (75) Inventeurs/Déposants (pour US seulement) : LABARRIERE, Eric [FR/FR]; Le Mas Presleu, F-01800 SAINT-ELOI (FR). BEATI, Angelo [FR/FR]; COLI, rue Corneille, F-69003 LYON (FR). BONNAMOUR, Michel [FR/FR]; 9 bis, rue du transvaal, F-69008 LYON (FR).
- (74) Mandataires : DOMENEGO, Bertrand etc.; Cabinet LAVOIX, 2, place d'Estienne d'Orves, F-75441 PARIS CEDEX 09 (FR).
- (81) États désignés (sauf indication contraire pour tout titre de protection nationale disponible) : AE, AG, AL, AM, AT, AU, AZ, BA, BB, BG, BR, BW, BY, BZ, CA, CH, CN, CO, CR, CU, CZ, DE, DK, DM, DZ, EC, EE, EG, ES, FI, GB, GD, GE, GH, GM, HR, HU, ID, IL, IN, IS, JP, KE, KG,

[Suite sur la page suivante]

(54) Title: FUEL ASSEMBLY END CAP COMPRISING A COOLANT-FLOW-ORIENTING NOZZLE AND CORRESPONDING ASSEMBLY

(54) Titre : EMBOUT D'EXTREMITÉ POUR ASSEMBLAGE COMBUSTIBLE A NEZ D'ORIENTATION DE L'ÉCOULEMENT DU FLUIDE RÉFRIGÉRANT ET ASSEMBLAGE CORRESPONDANT

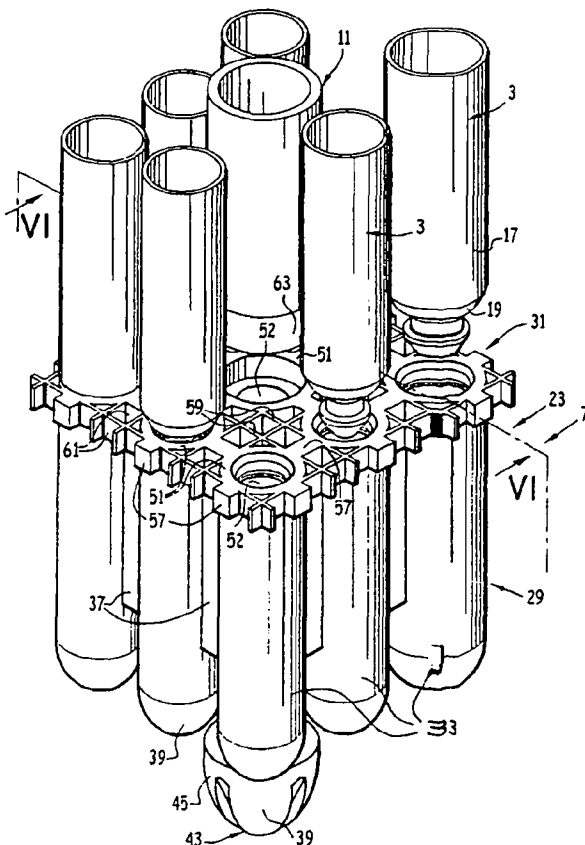

(57) Abstract: The invention relates to an end cap comprising nozzles (39) for orienting the flow of coolant from the reactor along the length of the adjacent longitudinal ends (19) of fuel rods (3) in a fuel assembly. According to the invention, the nozzles (39) are disposed at nodes in the same network as the fuel rods (3) in order to be positioned in the longitudinal extension of at least some of said fuel rods (3) and/or at least some of the connecting elements (11) of the support skeleton.

(57) Abrégé : Cet embout comprend des nez (39) d'orientation de l'écoulement d'un fluide réfrigérant du réacteur le long des extrémités longitudinales adjacentes (19) des crayons de combustible (3) d'un assemblage combustible. Les nez (39) sont disposés en des nœuds du même réseau que les crayons de combustible (3) pour être placés dans le prolongement longitudinal d'au moins certains des crayons de combustible (3) et/ou d'au moins certains des éléments de liaison (11) du squelette de support.

WO 2005/066976 A2

**Terminal end-piece for a fuel assembly having a nose for orientating the flow of coolant fluid and corresponding as sembly**

The present invention relates to a terminal end-piece for a nuclear reactor fuel assembly, the assembly comprising fuel rods and a skeleton for supporting the fuel rods, the fuel rods extending in a longitudinal direction and being arranged at the nodes of a substantially regular network, the support skeleton comprising two terminal end-pieces and elements for connecting the terminal end-pieces, the fuel rods being arranged longitudinally between the terminal end-pieces.

The invention is used in particular for constructing bottom end-pieces of fuel assemblies for pressurised water nuclear reactors (PWR).

EP-537 044 describes a bottom end-piece for such an assembly. That end-piece comprises a horizontal wall which is provided with feet for support on the lower plate of a nuclear reactor core. The elements for connecting the bottom end-piece to the top end-piece are constituted by guide tubes. Those guide tubes are fixed to the horizontal wall of the end-piece. The horizontal wall comprises reinforcement ribs under the lower surface thereof. In each zone of the horizontal wall delimited between the reinforcement ribs, holes for the passage of coolant water are provided so that the horizontal wall constitutes an anti-debris filter.

The coolant water flows in the core of the reactor vertically in an upward direction. More precisely, the water is introduced into the core through the lower core plate, then passes through the bottom end-piece by way of the

above-mentioned holes before coming into contact with the outer surfaces of the fuel rods.

The water flows in the core at a very high ascending rate.

It has been found, during operation of the core, that the fuel rods, and in particular the lower ends thereof, were subjected to vibrations which are liable to damage them.

In greater detail, phenomena involving friction or "fretting" are liable to occur in particular between the lower grid of the support skeleton and the outer claddings of the fuel rods.

These friction phenomena may lead to damage to outer claddings which may bring about a release of fission gas or product in the water of the primary circuit.

An object of the invention is to overcome this problem by limiting the vibrations of the fuel rods of assemblies for a nuclear reactor.

To that end, the invention relates to a terminal end-piece for a nuclear reactor fuel assembly, the assembly comprising fuel rods and a skeleton for supporting the fuel rods, the fuel rods extending in a longitudinal direction and being arranged at the nodes of a substantially regular network, the support skeleton comprising two terminal end-pieces and elements for connecting the terminal end-pieces, the fuel rods being arranged longitudinally between the terminal end-pieces,

characterised in that the end-piece comprises noses for orientating the flow of a coolant fluid of the reactor along the adjacent longitudinal ends of the fuel rods, the noses

being arranged in nodes of the substantially regular network in order to be positioned in a longitudinal continuation of at least some of the fuel rods and/or at least some of the connection elements of the support skeleton.

According to specific embodiments, the end-piece may comprise one or more of the following features, taken in isolation or according to any technically possible combination:

- the noses converge in a direction which is intended to be orientated towards the outer side of the fuel assembly,
- at least some of the noses belong to members for fixing the terminal end-piece to connection elements of the support skeleton or fuel rods,
- the fixing members are screws,
- the end-piece comprises means for laterally maintaining adjacent longitudinal ends of the fuel rods, which maintenance means are arranged in nodes of the substantially regular network,
- the maintenance means comprise housings for receiving the adjacent longitudinal ends of the fuel rods,
- the maintenance means constitute means for longitudinally securing the adjacent longitudinal ends of the fuel rods relative to the terminal end-piece,
- the end-piece comprises two components for clamping between them the adjacent longitudinal ends of the fuel rods,
- the end-piece comprises an anti-debris filter,
- one of the components constitutes the anti-debris filter,
- the end-piece constitutes a bottom end-piece and
- the end-piece comprises feet for support on a lower plate of the nuclear reactor core.

The invention further relates to a fuel assembly for a nuclear reactor, the assembly comprising fuel rods and a skeleton for supporting the fuel rods, the fuel rods extending in a longitudinal direction and being arranged at the nodes of a substantially regular network, the support skeleton comprising two terminal end-pieces and elements for connecting the terminal end-pieces, the fuel rods being arranged longitudinally between the terminal end-pieces, characterised in that at least one end-piece is an end-piece as defined above.

According to specific embodiments, the assembly may comprise one or more of the following features, taken in isolation or according to any technically possible combination:

- the end-piece comprises means for laterally maintaining adjacent longitudinal ends of the fuel rods, which maintenance means are arranged in nodes of the substantially regular network,
- the maintenance means comprise housings which receive the adjacent longitudinal ends of the fuel rods,
- the maintenance means constitute means for longitudinally securing the adjacent longitudinal ends of the fuel rods relative to the terminal end-piece,
- the end-piece comprises two components which clamp between them the adjacent longitudinal ends of the fuel rods,
- the longitudinal securing means comprise projections which are provided on the end-piece and rings which are provided at the adjacent longitudinal ends of the fuel rods and which are fitted to those projections,
- the rings comprise relief portions for abutment against one of the components,

- the adjacent longitudinal ends of the fuel rods comprise widened feet which are clamped between the two components,
- the adjacent longitudinal ends of the fuel rods are expansion-rolled on the end-piece,
- the longitudinal securing means comprise screws which abut the end-piece and which are engaged in the adjacent longitudinal ends of the fuel rods and
- the longitudinal securing means are means for securing by means of snap-fitting.

The invention will be better understood from a reading of the following description given purely by way of example and with reference to the appended drawings, in which:

- Figure 1 is a schematic side view of a fuel assembly according to the prior art,
- Figure 2 is a schematic top view showing the distribution of the fuel rods in the assembly of Figure 1,
- Figure 3 is a schematic bottom view of the bottom end-piece of a fuel assembly according to a first variant of a first embodiment of the invention,
- Figure 4 is a schematic perspective view of the end-piece of Figure 3,
- Figure 5 is a schematic partial, perspective, exploded view showing the connection of the bottom end-piece of Figure 3 to the fuel rods and the guide tubes,
- Figure 6 is a partial, schematic view, sectioned along the plane VI-VI of Figure 5, illustrating the connection between the bottom end-piece, the guide tubes and the fuel rods,
- Figure 7 is a partial, schematic top view illustrating the connection of a foot to the remainder of the bottom end-piece of Figure 3,

- Figure 8 is a schematic partial perspective view illustrating a second variant of the first embodiment of the invention,

- Figure 9 is a schematic, partially sectioned side view showing a first variant of a bottom end-piece according to a second embodiment of the invention and

- Figures 10 to 13 are views similar to Figure 9 illustrating other variants of the second embodiment of the invention.

In order to illustrate the context of the invention, Figure 1 schematically illustrates a nuclear fuel assembly 1 for a pressurised water reactor. Therefore, the water fulfils in that case a coolant and moderating function, that is to say, slowing down the neutrons produced by the nuclear fuel.

The assembly 1 extends vertically and in a rectilinear manner in a longitudinal direction A.

Conventionally, the assembly 1 principally comprises nuclear fuel rods 3 and a structure or skeleton 5 for supporting the rods 3.

The support skeleton 5 conventionally comprises:

- a bottom end-piece 7 and a top end-piece 9 which are arranged at the longitudinal ends of the assembly 1,
- guide tubes 11 which are intended to receive the rods of an assembly (not illustrated) for controlling and stopping the nuclear reactor and
- grids 13 for maintaining the rods 3.

The end-pieces 7 and 9 are fixed to the longitudinal ends of the guide tubes 11.

The rods 3 extend vertically between the end-pieces 7 and 9. The rods 3 are arranged at the nodes of a substantially regular network having a square base, where they are maintained by the grids 13. Some of the nodes of the network are occupied by the guide tubes 11 and optionally by an instrumentation tube 14 which is visible at the centre of Figure 2. In Figure 2, the rods 3 are shown with dashed lines, the guide tubes 11 are shown with solid lines and the instrumentation tube 14 is shown using a solid black circle.

The grids 13 conventionally comprise sets of intersecting plates 15 which together delimit cells which are centred on the nodes of the regular network. Most of the cells are intended to receive a fuel rod 3. 24 cells each receive a guide tube 11 and the central cell receives the instrumentation tube 14.

In the example of Figures 1 and 2, the maintenance grids 13 comprise 17 cells per side and the regular network comprises the same number of nodes per side.

In other variants the number of cells and nodes per side may be different, for example, in the order of 14 x 14 or 15 x 15.

Each rod 3 conventionally comprises an outer cladding 17 which is closed by a lower plug 19 and an upper plug 21 and which contains the nuclear fuel. These are, for example, stacked pellets of fuel, the pellets being supported on the lower plug 19.

A helical maintenance spring (not illustrated) may be arranged in the cladding 17 between the upper pellet and the upper plug 21.

Figures 3 to 7 illustrate a bottom end-piece 7 according to the invention which may be fitted to an assembly 1 as described with reference to Figures 1 and 2. Preferably, the maintenance grids 13 are grids such as those described in documents US-6 542 567 and EP-925 589. In some variants, the end-piece 7 may further be fitted to assemblies which are different from that described above and/or which comprise different maintenance grids.

The end-piece 7 comprises a horizontal wall 23 and feet 25 which extend the wall 23 downwards in order to be supported on the lower plate of the core of the reactor.

The wall 23 is generally of planar parallelepipedal form and the feet 25 are each arranged at a corner of the wall 23. The wall 23 comprises a lower member 29 and an upper plate 31 which covers the member 29.

The lower member 29 comprises a plurality of units 33 which are arranged at the nodes of the same network as the fuel rods 3, the guide tubes 11 and the instrumentation tube 14.

In this manner, as is visible in Figure 3, the member 29 comprises 17 x 17 units 33 of cylindrical shape.

Therefore, each unit 33 is located longitudinally below a fuel rod 3, a guide tube 11 or the instrumentation tube 14, if the assembly 1 comprises them.

The units 33 are connected to each other by reinforcement ribs 37 which form a grid-like square around the lower member 29.

The units 33 which are arranged under the fuel rods 3, that is to say, most of the units 33, have a diameter substantially corresponding to the outer diameter of the rods 3 and are extended downwards by noses 39. Those noses 39 are substantially of ogive-like forms converging downwards. Those noses 39 are integrally formed with the respective units 33.

As can be seen in Figures 3 and 6, the units 33 arranged below the guide tubes 11 and the instrumentation tube 14 do not comprise integrated noses 39, but are instead perforated by vertical holes 41. For each unit 33 arranged under a guide tube 11, the hole 41 is a hole for receiving the shank of a screw 43 for fixing the end-piece 7 to the relevant guide tube 11. It will be appreciated that the head 45 of the screw 43 is substantially of ogive-like form and also constitutes a nose 39 which is arranged under the respective unit 33. It should be noted that the screws 43 have not been illustrated in Figure 3.

The hole 41 of the central unit 33 which is arranged under the instrumentation tube 14 is itself left free in order to allow the introduction of the probe of the instrumentation tube 14.

In this manner, the lower member 29 of the end-piece 7 has a network of noses 39 that is similar to that of the fuel rods 3 and the guide tubes 11.

That network is interrupted only in the region of the instrumentation tube 14. In some variants, the network may also be interrupted locally in the region of that tube 14 in a more significant manner.

In those variants, however, the majority of the rods 3 remain arranged above noses 39.

The units 33 which are arranged below the fuel rods 3 further have blind holes 47 which open in the upper surface of the lower member 29. Those holes 47 have upper portions 49 which diverge upwards.

As illustrated in Figures 5 and 6, the upper plate 31 comprises rings 51 which are arranged at the nodes of the same substantially regular network as the units 33. The internal passages 52 of the rings 51 arranged below the fuel rods 3 have upper portions 53 which diverge upwards and substantially cylindrical lower portions 55 which are arranged in a continuation of the upper divergent portions 49 of the blind holes 47. The outer diameter of those rings 51 is substantially equal to that of the rods 3.

The internal passages 52 of the rings 51 arranged under the guide tubes 11 and the instrumentation tube 14 are, for example, of cylindrical form. The outer diameter of those rings 51 is substantially equal to that of the guide tubes 11 and the instrumentation tube 14.

The rings 51 are connected to each other by reinforcement ribs 57 which are arranged, for example, in grid-like form similar to that of the ribs 37 of the lower member 29.

When the upper plate 31 covers the lower member 29 of the end-piece 7, as can be seen in Figures 5 and 6, the ribs 57 are arranged above the ribs 37 of the member 29, the rings 51 are arranged above the units 33. Therefore, there is longitudinal continuity between the member 29 and the plate 31.

Plates 59, which are finer than the ribs 57, extend between the rings 51 and the ribs 57 in order to delimit, in the plate 31, holes 61 for the passage and filtration of the coolant water. In the example illustrated, the plates 59 are arranged in grid-like form.

In this manner, the upper plate 31 forms an anti-debris filter.

As illustrated in greater detail in Figures 5 and 6, the shanks 62 of the screws 43 for fixing the guide tubes 11 extend through the corresponding holes 41 and are engaged in lower plugs 63 which are fixedly joined to the guide tubes 11. The plugs 63 are then supported on the upper plate 31 and the heads 45 of the screws 43 abut under the lower member 29.

The upper plate 31 and the lower member 29 adjoin each other and the end-piece 7 is fixedly joined to the remainder of the support skeleton 5.

As is visible in Figure 7, the feet 25 have, for example, been fixed to the corners of the lower member 29 by means of fixing screws 65.

It will be appreciated that, in Figure 7, the unit network 33 has been illustrated only partially and the structure thereof has not been shown in detail.

The passages 52 of the rings 51 arranged under the fuel rods 3 and the blind holes 47 of the units 33 arranged below form housings 67 for receiving the lower plugs 19 of the fuel rods 3.

In the example illustrated in Figures 3 to 7, the lower plugs 19 are supported on the upper divergent portions 53 of those passages 67 via regions of complementary shape. The rods 3 are thus all maintained laterally via their lower ends relative to the bottom end-piece 7. The upper ends of the rods 3 are, for example, free as in the prior art and are not maintained by the top end piece 9.

The presence of the noses 39, which are positioned in a continuation of the rods 3 and the guide tubes 11, allows the flow paths to be orientated substantially vertically along the lower ends of the rods 3 and therefore the lateral rates of flow of the water to be reduced.

The vibrations of the lower ends of the rods 3 are thereby reduced during operation of the reactor.

The risks of vibration of the rods 3 are still further reduced because the lower ends of the rods 3 are laterally maintained by the end-piece 7 itself. In this manner, the vibrations of the rods 3 are limited up to such a point that it is possible to dispense with the lower maintenance grid 13.

The risks of damage owing to fretting of the claddings 17 of the fuel rods 3 are therefore limited.

It will be appreciated that the end-piece 7 further has good transparency with respect to the flow of water and therefore does not bring about any great pressure drop.

In general terms, forms other than ogive-like forms may be envisaged for the noses 39 for longitudinally orientating the flow in the region of the lower ends of the rods 3.

Thus, these may be in particular forms which converge towards the bottom, such as conical forms.

Furthermore, the density of the noses 39 may be less than in the example described above, so long as the majority of the rods 3 are arranged above noses 39.

Typically, the bottom end-piece 7 may be constructed from stainless steel or a zirconium alloy.

It can be constructed by any conventional method.

In this manner, the member 29 and the plate 31 can be constructed either by moulding or by a method using abrasive jets of water at a very high pressure (several thousands of bar), the water being able to be loaded with abrasive particles.

As illustrated by the variant of Figure 8, the horizontal wall 23 of the bottom end-piece 7 is not necessarily constituted by two portions.

Thus, in that variant, the anti-debris filter is integrated in the member 29, that is to say that the plates 59 extend between the reinforcement ribs 37.

In the variant of Figure 8, it will also be appreciated that the feet 25 are, similarly to the plates 59, integrally formed with the member 29.

The bottom end-piece 7 is constructed in one piece.

It will also be appreciated that noses 39 arranged in a network substantially corresponding to that of the rods 3 can be used irrespective of the presence on the end-piece 7 of means for maintaining the lower ends of the rods 3.

Conversely, the maintenance of the rods 3 by the bottom end-piece 7 may be more extensive and may include longitudinal securing, as illustrated by the second embodiment of the invention.

The first variant of this embodiment, illustrated in Figure 9, differs from that of Figures 1 to 7 principally in that the units 33 arranged longitudinally below the fuel rods 3 are extended upwards by projections 71 which are bordered by circular grooves 73.

The lower plugs 19 of the rods 3 are extended downwards by substantially cylindrical rings 75. Those rings 75 are split in order to have resiliently deformable tongues 77.

Each ring 75 is deformed in order to have a curved protuberance constituting a circular enlargement 79.

The inner diameter of the ring 75 is slightly smaller than the outer diameter of the projections 71.

In order to assemble the fuel rods 3 at the bottom end-piece 7, it is necessary to proceed as illustrated by the left-hand portion of Figure 9.

The upper plate 31 has been fitted on the fuel rods 3 beforehand by passing the upper ends of the fuel rods 3 into the internal passages 52 of the rings 51.

Subsequently, the rings 75 are fitted on the projections 71, as indicated by the arrow 81 in the left-hand portion of Figure 9.

During that fitting operation, the tongues 77 are slightly resiliently deformed in a laterally outward direction.

Next, the upper plate 31 is lowered until it moves into abutment against the lower member 29, as illustrated by the right-hand portion of Figure 9.

Lower portions 83 of the passages 52 of the rings 51 then move into abutment against the enlargement 79. Those lower portions 83 are, for example, of forms which diverge towards the bottom.

Fixing the bottom end-piece 7 to the guide tubes 11 by means of the screws 43 described above completes the assembly of the support skeleton 5.

The upper plate 31 is then maintained in a state longitudinally abutting the lower member 29 and thereby

longitudinally clamps the lower ends of the rods 3 against the member 29 by means of the enlargements 79.

All the fuel rods 3 are then secured longitudinally and laterally relative to the bottom end-piece 7, thereby bringing about lateral securing of the rods 3 relative to the end-piece 7, which further reduces the risks of vibrations of the fuel rods 3 and damage owing to fretting.

Figure 10 illustrates a second variant of this embodiment.

In this variant, the rings 75 have outer diameters which are reduced further, and are therefore smaller than the outer diameter of the claddings 17 of the fuel rods 3. The rings 75 are connected by shoulders 85 to the lateral surfaces of the lower plugs 19. The central passages 52 of the rings 51 have, in addition to the lower diverging portion 83, an upper portion 87 which diverges towards the top.

The outer diameter of the projections 71 is reduced further than in the first variant of Figure 9.

In order to assemble the fuel rods 3 at the bottom end-piece 7, first the rings 75 are introduced in the passages 52 of the rings 51 of the grid 31, as indicated by the arrow 88 at the left-hand portion of Figure 10. During that introduction operation, the tongues 77 become resiliently deformed laterally towards the inner side until the enlargements 79 are positioned below the frustoconical portions 83 and the shoulders 85 abut the upper surface of the anti-debris grid 31. The lower plugs 19 of the rods 3 are then assembled by being engaged with the upper grid 31.

Subsequently, the upper grid 31 is moved into abutment against the lower unit 29 so that the projections 71 are introduced inside the rings 75. The projections 71 prevent deformation of the plates 77 and therefore the lower plugs 19 from being disengaged from the upper plate 31.

Fixing the bottom end-piece 7 to the guide tubes 11 by means of the screws 43 completes the construction of the support skeleton 5.

In that second variant, the lower ends of the fuel rods 3 are also secured longitudinally and laterally relative to the end-piece 7.

In the third variant of Figure 11, the lower plugs 19 of the fuel rods 3 comprise widened lower feet 89, for example, in the form of discs having a diameter greater than the outer diameter of the external claddings 17.

After fitting the fuel rods 3, by means of the upper ends thereof, in the rings 51 of the grid 31, those feet 89 engage in lower countersinkings 91 which are provided in the rings 51. The feet 89, and therefore the lower ends of the fuel rods 3, are therefore secured longitudinally between the lower member 29 of the end-piece 7 and the upper plate 31, by means of the screws 43 for fixing to the guide tubes 11.

In the variant of Figure 12, the lower plugs 19 of the fuel rods 3 also comprise rings 75 which, however, are not split. Those rings 75 have been introduced in the passages 52 of the rings 51 and fixed to the rings 51 by expansion-rolling.

The lower ends of the fuel rods 3 are therefore secured longitudinally and laterally to the upper plate 31 of the bottom end-piece 7 which is itself fixed, by the screws 43, to the member 29 of the bottom end-piece 7.

Figure 13 illustrates still another variant, in which the securing of the fuel rods 3 to the end-piece 7 is brought about by means of screws 43 similar to those used for fixing to the guide tubes 11.

Thus, each nose 39 arranged below a rod 3 is formed by a head 45 of a screw 43, whose shank 62 extends through the corresponding unit 33 and which is screwed in the lower plug 19 of the corresponding rod 3.

In each of the embodiments and in each of the variants described above, it is possible for the end-piece 7 not to comprise an anti-debris filter.

It will again be appreciated that the presence, in the end-piece 7, of maintenance means, or more preferably means for laterally and/or longitudinally securing all the rods 3, may be envisaged separately from the use of noses 39 for orientating the flow of coolant water along the rods 3 because they independently allow the risks of vibration of the fuel rods 3 to be limited.

In some variants, it is possible for some rods not to be maintained by the end-piece 7, but the majority of the rods remain in a maintained state.

More generally, the principles described above may be used not only for assemblies which are intended for pressurised

water reactors, but also for those intended for boiling water reactors (BWR).

CLAIMS

1. Terminal end-piece (7) for a fuel assembly (1) of a pressurised water nuclear reactor, the assembly (1) comprising fuel rods (3) and a skeleton (5) for supporting the fuel rods (3), the fuel rods (3) extending in a longitudinal direction (A) and being arranged at the nodes of a substantially regular network, the support skeleton (5) comprising two terminal end-pieces (7, 9) and guide tubes (11) which connect the terminal end-pieces, the fuel rods (3) being arranged longitudinally between the terminal end-pieces (7, 9), characterised in that the end-piece comprises noses (39) for orientating the flow of a coolant fluid of the reactor along the adjacent longitudinal ends (19) of the fuel rods (3), the noses (39) being arranged in nodes of the substantially regular network in order to be positioned in a longitudinal continuation of at least some of the fuel rods (3) and/or at least some of the guide tubes (11) of the support skeleton (5).
2. End-piece according to claim 1, characterised in that the noses (39) converge in a direction which is intended to be orientated towards the outer side of the fuel assembly (1).
3. End-piece according to claim 1 or 2, characterised in that at least some of the noses (39) belong to members (43) for fixing the terminal end-piece (7) to guide tubes (11) of the support skeleton (5) or fuel rods (3).
4. End-piece according to claim 3, characterised in that the fixing members are screws (43).

5. End-piece according to any one of the preceding claims, characterised in that it comprises means (67; 71, 83; 91; 51; 43) for laterally maintaining adjacent longitudinal ends (19) of the fuel rods (3), which maintenance means are arranged in nodes of the substantially regular network.
6. End-piece according to claim 5, characterised in that the maintenance means comprise housings (67) for receiving the adjacent longitudinal ends (19) of the fuel rods (3).
7. End-piece according to claim 5 or 6, characterised in that the maintenance means constitute means for longitudinally securing the adjacent longitudinal ends (19) of the fuel rods (3) relative to the terminal end-piece (7).
8. End-piece according to claim 7, characterised in that the end-piece comprises two components (29, 31) for clamping between them the adjacent longitudinal ends (19) of the fuel rods (3).
9. End-piece according to any one of the preceding claims, characterised in that it comprises an anti-debris filter (31).
10. End-piece according to claims 8 and 9 taken together, characterised in that one of the components constitutes the anti-debris filter (31).
11. End-piece according to any one of the preceding claims, characterised in that it constitutes a bottom end-piece.
12. End-piece according to claim 11, characterised in that it comprises feet (25) for support on a lower plate of the nuclear reactor core.

13. Fuel assembly (1) for a pressurised water nuclear reactor, the assembly (1) comprising fuel rods (3) and a skeleton (5) for supporting the fuel rods (3), the fuel rods (3) extending in a longitudinal direction (A) and being arranged at the nodes of a substantially regular network, the support skeleton (5) comprising two terminal end-pieces (7, 9) and guide tubes (11) which connect the terminal end-pieces, the fuel rods (3) being arranged longitudinally between the terminal end-pieces (7, 9), characterised in that at least one end-piece (7) is an end-piece according to any one of the preceding claims.

14. Assembly according to claim 13, characterised in that the end-piece (7) comprises means (67; 71, 83; 51; 43) for laterally maintaining adjacent longitudinal ends (19) of the fuel rods (3), which maintenance means are arranged in nodes of the substantially regular network.

15. Assembly according to claim 14, characterised in that the maintenance means comprise housings (67) which receive the adjacent longitudinal ends (19) of the fuel rods (3).

16. Assembly according to claim 14 or 15, characterised in that the maintenance means constitute means for longitudinally securing the adjacent longitudinal ends (19) of the fuel rods (3) relative to the terminal end-piece (7).

17. Assembly according to claim 16, characterised in that the end-piece (7) comprises two components (29, 31) which clamp between them the adjacent longitudinal ends (19) of the fuel rods (3).

18. Assembly according to claim 17, characterised in that the longitudinal securing means comprise projections (71) which are provided on the end-piece (7) and rings (75) which are provided at the adjacent longitudinal ends (19) of the fuel rods (3) and which are fitted to those projections (71) .

19. Assembly according to claims 17 and 18 taken together, characterised in that the rings (75) comprise relief portions (79) for abutment against one of the components (29, 31) .

20. Assembly according to claim 17, characterised in that the adjacent longitudinal ends (19) of the fuel rods (3) comprise widened feet (89) which are clamped between the two components (29, 31) .

21. Assembly according to claim 16, characterised in that the adjacent longitudinal ends (19) of the fuel rods (3) are expansion-rolled on the end-piece (7) .

22. Assembly according to any one of claims 16 to 20, characterised in that the longitudinal securing means comprise screws (43) which abut the end-piece (7) and which are engaged in the adjacent longitudinal ends (19) of the fuel rods (3) .

23. Assembly according to any one of claims 16 to 20, characterised in that the longitudinal securing means are means for securing by means of snap-fitting (Figure 10) .