

G. MARSHALL.
Railway-Car Brake.

No. 213,915.

Patented April 1, 1879.

Fig. 1

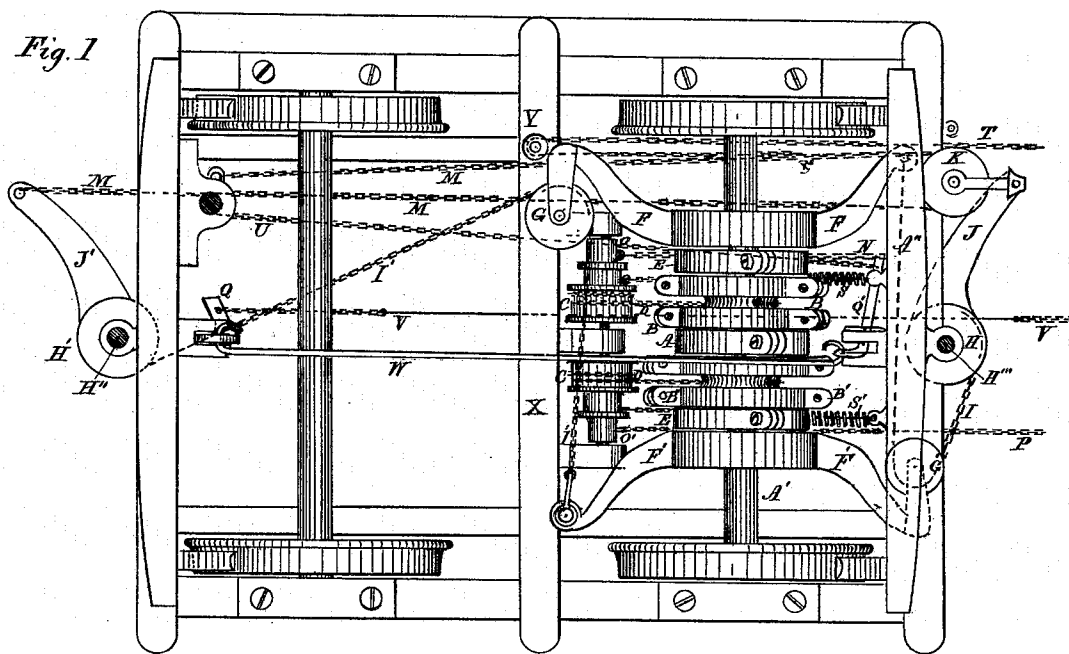
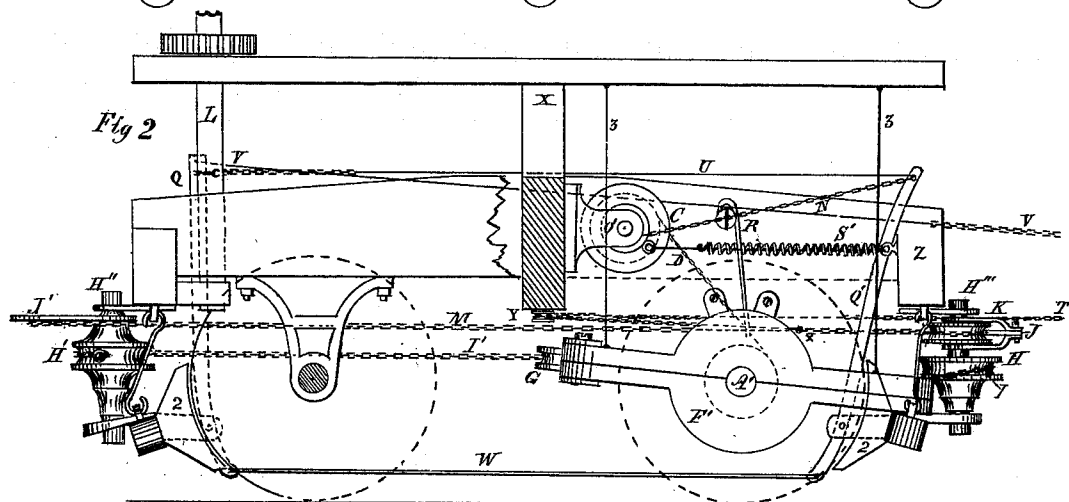

Fig 2



Witnesses

W. M. Leishman
[Signature]

Inventor.

Gavin Marshall
 By *[Signature]*
 His att'y.

G. MARSHALL.
Railway-Car Brake.

No. 213,915.

Patented April 1, 1879.

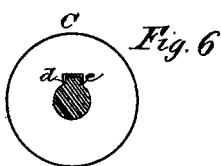
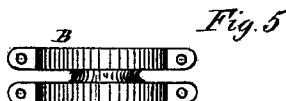
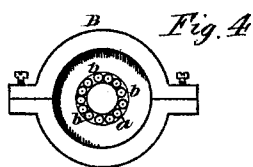
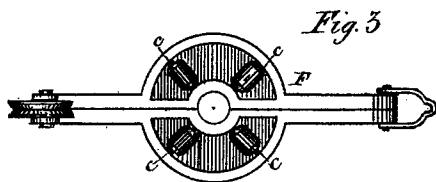

Witnesses

W. M. Leishman
W. H. Casser

Inventor:

Garin Marshall
By W. Bruce
His Att'y.

UNITED STATES PATENT OFFICE.

GAVIN MARSHALL, OF HAMILTON, ONTARIO, CANADA.

IMPROVEMENT IN RAILWAY-CAR BRAKES.

Specification forming part of Letters Patent No. **213,915**, dated April 1, 1879; application filed January 3, 1879.

To all whom it may concern:

Be it known that I, GAVIN MARSHALL, of the city of Hamilton, in the county of Wentworth, in the Province of Ontario, Dominion of Canada, wool-grader, have invented certain new and useful Improvements in Railway-Car Brakes; and I do hereby declare that the following is a full, clear, and exact description of the construction and operation of the same, reference being had to the accompanying drawings, forming part of this specification.

The invention relates to a very useful, economical, and effective device, attached to each truck of a car, and so constructed and arranged that the brakes can be applied to a whole train simultaneously by the engine-driver on the locomotive, or separately by a brakeman, who, if he is in the last car, can brake the entire train at once.

The brakes can be regulated so as to equalize the pressure on each car, and, when exerted from the engine, can brake the last car first, which will prevent concussion of the cars, as they will not come in sudden forcible contact, as they do with the ordinary method of applying the brakes. If absolute necessity requires, in cases of imminent danger, &c., the brakes can be applied simultaneously from both ends of the train, giving double pressure, with such power exerted on the car-wheels as to stop a train in a very short distance while running at a high rate of speed. An enormous pressure can be exerted on the brake-levers at the ends of each car—more than a car-truck can stand; but I obviate the danger of too much pressure by regulating-pulleys having a chain attached to each, which counteracts the pressure when too much is applied, and prevents the wheels from sliding on the rails.

The construction of my invention is such that when attached to the cars of a train it will not interfere with any existing parts of the present common system of brakes. It is durable, safe, effective, and economical. The whole cost of putting it on a passenger-car would not exceed twenty-five dollars, (\$25,) and on freight-cars, say, thirteen dollars, (\$13.)

Another great advantage it possesses is: it is impossible for a train to break loose without the brakes being applied, for this reason,

that when the cars part, the connecting-rods tighten and the brakes are applied to a whole train at once, with less danger of getting out of order and breaking than with other brakes now in use.

In my improved car-brake mechanism a central friction-wheel is secured stationary to one axle of each truck. On each side of said wheel is a loose grooved pulley on the same axle, and on each side of said loose pulley is a sliding pulley, the two last being so constructed that they move slightly back and forth on a line with the car-axle, the use of which will be more fully explained hereinafter.

On the same axle above mentioned are placed two axle-levers, one on each side of the respective pulleys, each being provided with a pulley, respectively, from which chains are made to pass to other pulleys and levers at the end of a car, so that when pressure is brought to bear on said chains the axle-levers and pulleys on the shaft act upon the shaft to bind it and retard its revolution; at the same time the brakes are pressed on the wheels in the usual way.

I construct a series of separate pulleys on a shaft attached to the center truck-beam, having chains passing from the central and largest ones to the central and loose pulleys opposite them on the axle, for the purpose of tightening the latter on the axle when the brakes are applied.

I construct at either end of a car a pulley, secured to a vertical spindle journaled in proper bearings attached to the car-frame and brake-beam. Also, a brake-beam lever is attached to same vertical spindle at each end, respectively, to one of which levers a pulley is attached for a chain to pass easily around.

Chains and connecting-rods pass from one device to the other to transmit power from them to the brakes, and, while not disturbing the brakes used at present on railway-cars, I merely add my device, and connect them in such a manner that they can be operated from the existing brake-wheel.

Figure 1 represents a plan view of the under side of a car-truck. Fig. 2 is a side view of the same. Fig. 3 is an inside view of one of the axle-levers. Fig. 4 is a side view of one of

the grooved friction-pulleys on the axle. Fig. 5 is a top view of same.

Fig. 1 is only one truck of a car, viewed on the under side, which causes the connecting-chains to appear at first sight slightly complicated; but it will be observed that the brake device is attached to both trucks of a car, and the end pulleys and levers at the extreme end of each car, so that the said Fig. 1 will represent an entire car.

A is a metallic friction-wheel, securely fastened to the axle A', the use of which is to assist to revolve the two friction-pulleys, which will be described hereinafter.

B B' are grooved friction-pulleys, placed one on each side of the said friction-wheel A, loose upon the axle A'. They are provided each with a recess, *a*, on the side, and also a series of small anti-friction rollers, *b*, surrounding the axle A', as shown in Fig. 4, Sheet 2. The operation of these pulleys will be more fully explained hereinafter.

C C' are two pulleys, placed opposite the said pulleys B B', and are attached to pulley-shafts O O', secured in bearings to the center truck-beam, X. Chains D D pass from said pulleys B B' to said pulleys C C', the use of which will be explained hereinafter.

E E' are two friction-wheels on the axle A', one on each side of the pulleys B and B'. They are provided with a square groove, *c*, Fig. 6, cut in their inner portion next the axle, the axle also being provided with a corresponding projection, *d*, so as to allow the said wheels to move back and forth longitudinally on the shaft when pressed or released by the other pulleys and devices on each side of them.

F F' are two metallic axle-levers, placed on the said axle A', one on each side, respectively, of all pulleys on the said axle. Each is provided on the inner face with four small anti-friction rollers, *c c c c*, as shown in Fig. 3, Sheet 2, for the purpose of allowing the wheels E and E' to play more easily. Each of the said axle-levers F F' has attached to one arm, respectively, a pulley, G and G', for the lever-chains to work through.

H H' are brake-beam pulleys, fastened to vertical shafts H'' and H''', attached to the brake-beam and truck-beam at each end of a car, and are for the purpose of carrying the axle-lever chains I I', which act to tighten the friction-wheels B B' and E E' all together.

J J' are brake-beam levers, secured to the vertical shafts H'' and H''', respectively. One of the said levers has a pulley, K, attached, which is for the purpose of carrying the brake-beam pulley-chain M, which passes first from the lever J' to pulley K on the end of lever J, and thence to the brake-stem L.

N is a short connection-chain, passing from shaft O to the brake-beam lever Q.

P is a chain fastened to the shaft O', (which moves independent of shaft O,) and passes to the brake-stem chain of the next car, and is

for the purpose of operating on the brake-beams and brakes when pressure is put upon it by the pulley C.

Q Q' are the ordinary brake-levers at present in use, and which I do not alter.

R is one of two axle-lever springs, attached to the truck-beam, and is for the purpose of keeping the axle-levers F F' from the friction-wheels E E' when the brakes are off. I may use an equivalent device for the same purpose.

S S' are two chains, the former being fastened at one end to the shaft O, and the other end to a strong spiral spring, which, in turn, is secured to the brake-beam A'', the chain, however, also passing through the center of the spring to its termination, and secured to the truck-beam, as shown. The latter chain, S', is fastened on the other side at O', and the other end to a similar spiral spring, described, and arranged and secured the same way to the truck-beam A''. The said chains are for the purpose of counteracting the pressure of the chains on the pulleys C C'.

T is a rod and chain which connects the locomotive to every car of a train. It passes around a pulley, Y, attached to the center beam, X, of the last truck. It is fastened to the brake-stem pulley-chain M at the point *x'*, and its object is to operate the brakes on the last car from the locomotive, which, when done, puts the brakes on all the cars of a train at the same time.

U is a chain passing from the brake-stem L to the inside lever, Q, and forms what is called the "short connection," and is for the purpose of applying the brakes to the wheels on each truck. V is what is called the "long connection-rod," passing from the brake-lever Q to a similar lever on the next truck of the same car. W is the lower connection-rod, passing from the lower part of the lever Q to the lever Q', and is for the purpose of applying the brakes. X is the center truck-beam, and Y a pulley fastened thereto, for the chain T to pass around only on the last car.

The operation of the device is as follows: By turning the brake-stem L by means of the brake-wheel on its upper end the chain M, which is attached to the truck-beam pulley-lever J, pulls on the chains I I', which tighten the axle-levers F F' against the friction-wheels E E' and B B', which grasp the axle, and motion is given to the pulleys C C' by means of the pulley-chains D D, which are fastened to each, respectively, and, when tightened, revolve the axles O and O'. The chain N, attached to the shaft O, puts the brakes on the same truck to which the device is attached, and the chain P, attached to the shaft O', puts the brakes on the next car, an extra pressure on the chains of the pulleys C C' being counteracted by the chain and springs S and S'.

It will be observed that pulley H' could be placed on the center truck-beam, X, which would shorten the chains and equalize the pressure on the friction-wheels; and it will also

be observed that the pulley G on the arm of the axle-lever F could, without disadvantage, be placed on the arm of the axle-lever F', which would have a tendency to equalize the power on the friction-wheels on the axle.

The axle-levers F and F' are kept in their horizontal position by means of a rod, 3, attached to each arm and to the bottom of the car, which prevents them from oscillating.

What I claim as my invention is—

1. In combination with a car-wheel axle, the brake-levers F F', provided with anti-friction rollers c, said levers also being provided with pulleys G G' and the chain I, passing from the arm of the lever F around the pulley G', and secured to the pulley H, and the chain I', passing from one arm of the lever F' to pulley G on the opposite lever, F, substantially as and for the purpose specified.

2. In combination with a car-axle, a stationary central wheel, A, the pulleys E E', and the grooved pulleys B B', the latter being provided with anti-friction rollers b next the axle, to prevent wear, as specified.

3. The combination, with the car-axle, of the pulleys C C', chains D D, friction-pulleys B B', chains N P, connected to the brakes, the friction-pulleys E E', moving longitudinally on the axle, and suitable means for operating said pulleys, substantially as described, and for the purpose set forth.

4. In combination with a car-truck, the levers J J', secured to shafts H'' H''', pulleys H H', chains I, passing through suitable guides, the levers F F', and the friction-wheels, con-

nected by suitable intermediate mechanism with the devices operating the car-brakes, substantially as described.

5. The combination, with the axles O O', of pulleys C C', chains D D, connected to friction-pulleys B B, and chains N P, connected to the car-wheel brakes, the chains and springs S S' having each one end fixed and the other end attached to said axles, respectively, substantially as described, and for the purpose set forth.

6. The combination, with the car-brake-mechanism-operating chain M, of the chain T, adapted for connection with a suitable operating device upon a locomotive, substantially as and for the purpose described.

7. The combination, with the brake mechanism of a car, of the axle O', connected with and operating simultaneously with said mechanism, and the chain P, having one end connected to said axle, and the other end connected to brake mechanism of the preceding car in a train, substantially as and for the purpose set forth.

8. The combination of the pulleys C C' B' E E', wheel A, brake-levers F F', chains D D I I' M T P S S' N, to brake the axle in addition to the putting the brakes on the wheels, as specified.

Dated at Hamilton, Ontario, Canada, this 20th day of December, A. D. 1878.

GAVIN MARSHALL.

In presence of—

WM. BRUCE,
HAMILTON GARRETT.