

(19) World Intellectual Property Organization
International Bureau



(43) International Publication Date
26 May 2011 (26.05.2011)

PCT

(10) International Publication Number
WO 2011/063214 A1

(51) International Patent Classification:
G02B 6/00 (2006.01) F21V 8/00 (2006.01)
G02B 6/02 (2006.01)

(74) Agent: SHORT, Svetlana, Z.; Corning Incorporated, SP-Ti-3-1, Intellectual Property Department, Corning, NY 14831 (US).

(21) International Application Number:
PCT/US2010/057395

(81) Designated States (unless otherwise indicated, for every kind of national protection available): AE, AG, AL, AM, AO, AT, AU, AZ, BA, BB, BG, BH, BR, BW, BY, BZ, CA, CH, CL, CN, CO, CR, CU, CZ, DE, DK, DM, DO, DZ, EC, EE, EG, ES, FI, GB, GD, GE, GH, GM, GT, HN, HR, HU, ID, IL, IN, IS, JP, KE, KG, KM, KN, KP, KR, KZ, LA, LC, LK, LR, LS, LT, LU, LY, MA, MD, ME, MG, MK, MN, MW, MX, MY, MZ, NA, NG, NI, NO, NZ, OM, PE, PG, PH, PL, PT, RO, RS, RU, SC, SD, SE, SG, SK, SL, SM, ST, SV, SY, TH, TJ, TM, TN, TR, TT, TZ, UA, UG, US, UZ, VC, VN, ZA, ZM, ZW.

(22) International Filing Date:
19 November 2010 (19.11.2010)

(25) Filing Language: English

(26) Publication Language: English

(30) Priority Data:
61/263,023 20 November 2009 (20.11.2009) US

(71) Applicant (for all designated States except US): CORNING INCORPORATED [US/US]; 1 Riverfront Plaza, Corning, NY 14831 (US).

(84) Designated States (unless otherwise indicated, for every kind of regional protection available): ARIPO (BW, GH, GM, KE, LR, LS, MW, MZ, NA, SD, SL, SZ, TZ, UG, ZM, ZW), Eurasian (AM, AZ, BY, KG, KZ, MD, RU, TJ, TM), European (AL, AT, BE, BG, CH, CY, CZ, DE, DK, EE, ES, FI, FR, GB, GR, HR, HU, IE, IS, IT, LT, LU, LV, MC, MK, MT, NL, NO, PL, PT, RO, RS, SE, SI, SK, SM, TR), OAPI (BF, BJ, CF, CG, CI, CM, GA, GN, GQ, GW, ML, MR, NE, SN, TD, TG).

(72) Inventors; and

(75) Inventors/Applicants (for US only): BICKHAM, Scott, R. [US/US]; 69 E. 4th Street, Corning, NY 14830 (US). BOOKBINDER, Dana, C. [US/US]; 2675 Davis Road, Corning, NY 14830 (US). FEWKES, Edward, J. [US/US]; 330 West Avenue, Horseheads, NY 14845 (US). LOGUNOV, Stephan, L. [US/US]; 2780 Pinewood Circle, Corning, NY 14830 (US).

Published:

— with international search report (Art. 21(3))

[Continued on next page]

(54) Title: ILLUMINATION SYSTEM WITH SIDE - EMITTING OPTICAL PHOTONIC FIBRE AND MANUFACTURING METHOD THEREOF

FIG. 2

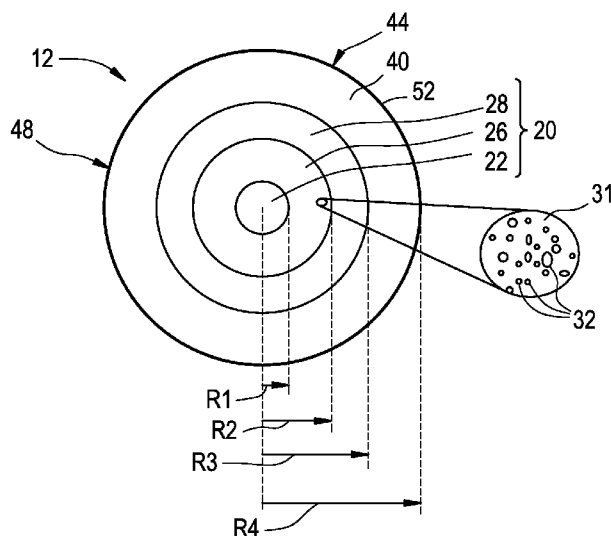

(57) Abstract: An illumination system generating light having a light source at at least one wavelength within 200 nm and an optical fiber (12) with a plurality of nano-sized structures (32) (e.g., voids). The optical fiber coupled to the light source. The light diffusing optical fiber has a core (12) and a cladding (40). The plurality of nano-sized structures is situated either within said core or at a core-cladding boundary. The optical fiber also includes an outer surface (48). The optical fiber is configured to scatter guided light via the nano-sized structures away from the core and through the outer surface, to form a light-source fiber portion having a length that emits substantially uniform radiation over its length, said fiber having a scattering-induced attenuation greater than 50 dB/km for the wavelength (s) within 200 nm to 2000nm range.



WO 2011/063214 A1

- *before the expiration of the time limit for amending the claims and to be republished in the event of receipt of amendments (Rule 48.2(h))*

ILLUMINATION SYSTEM WITH SIDE-EMITTING OPTICAL PHOTONIC FIBRE AND
MANUFACTURING METHOD THEREOF

BACKGROUND

[0001] This application claims the benefit of priority under 35 USC 119(e) of US Provisional Application Serial No. 61/263,023 filed November 20, 2009.

FIELD

[0002] The present invention relates generally to light diffusing optical fibers having a region with nano-sized structures, and in particular to illumination systems and methods that employ such fibers for different applications including bioreactors, signage and special lighting applications.

TECHNICAL BACKGROUND

[0003] Optical fibers are used for a variety of applications where light needs to be delivered from a light source to a remote location. Optical telecommunication systems, for example, rely on a network of optical fibers to transmit light from a service provider to system end-users.

[0004] Telecommunication optical fibers are designed to operate at near-infrared wavelengths in the range from 800 nm to 1675 nm where there are only relatively low levels of attenuation due to absorption and scattering. This allows most of the light injected into one end of the fiber to exit the opposite end of the fiber with only insubstantial amounts exiting peripherally through the sides of the fiber.

[0005] Recently, there has been a growing need to have optical fibers that are less sensitive to bending than conventional fibers. This is because more and more telecommunication systems are being deployed in configurations that require the optical fiber to be bent tightly. This need has led to the development of optical fibers that utilize a ring of small non-periodically disposed voids that surround the core region. The void containing ring serves to increase the bend insensitivity—that is to say, the fiber can have a smaller bend radius without suffering a significant change in the attenuation of the optical signal passing through. In these fibers the void containing ring region is placed in the cladding of the optical fiber some

distance from the core in order to minimize amount of the light propagation through void containing ring region, since it could increase optical loss.

[0006] Because optical fibers are typically designed to efficiently deliver light from one end of the fiber to the other end of the fiber over long distances, very little light escapes from the sides of the typical fiber, and, therefore optical fibers are not considered to be well-suited for use in forming an extended illumination source. Yet, there are a number of applications such as special lighting, signage, or biological applications, including bacteria growth and the production of photo-bioenergy and biomass fuels, where select amounts of light need to be provided in an efficient manner to the specified areas. For biomass growth there is a need to develop processes that convert light energy into biomass-based fuels. For special lighting the light source needs to be thin, flexible, and easily modified to variety of different shapes.

SUMMARY OF THE INVENTION

[0007] According to some embodiments, first aspect of the invention is an illumination system that generates light having at least one wavelength (λ) within the 200 nm to 2000 nm range. The system includes a light source and at least one light diffusing optical fiber. The light diffusing optical fiber has a core and a cladding. A plurality of nano-sized structures is situated either within said core or at a core-cladding boundary. The optical fiber also includes an outer surface, and an end optically coupled to the light source. The optical fiber is configured to scatter guided light via said nano-sized structures away from the core and through the outer surface, to form a light-source fiber portion having a length that emits substantially uniform radiation over its length, said fiber having a scattering-induced attenuation of greater than 50 dB/km for said wavelength. According to some embodiments the light source coupled to the fiber generates light in 200 nm to 500 nm wavelength range and fluorescent material in the fiber coating generates either white, green, red, or NIR (near infrared) light.

[0008] According to some embodiments, the illumination system includes a single light diffusing fiber. According to other embodiments the illumination system includes a plurality of light diffusing fibers. These light diffusing fibers may be utilized in a straight configuration, or may be bent.

[0009] According to some exemplary embodiments the illumination system may be used for a biological growth system, and may further include a biological chamber with an interior configured to contain biological material. In these embodiments a light source generates light

having a wavelength to which the biological material is sensitive. The fiber may have a plurality of bends formed therein so as to scatter guided light away from the central axis, out of the core, and through the outer surface to form a light-source fiber portion having a length that emits substantially uniform radiation over its length.

[0010] Additional features and advantages of the invention will be set forth in the detailed description which follows, and in part will be readily apparent to those skilled in the art from that description or recognized by practicing the invention as described herein, including the detailed description which follows, the claims, as well as the appended drawings.

[0011] Thus, one advantageous feature of at least some embodiments of the present invention is that the illumination systems and methods that utilize the optical fibers' ability to efficiently deliver light to remote locations and that such fibers will scatter light relatively uniformly even when deployed in different shapes (e.g., bent, coiled or straight) to match the needs of application. In addition, one advantageous feature of some embodiments of the present invention is that the light diffusing fibers according to at least some of the exemplary embodiments of the present invention are capable of providing illumination with a weak wavelength dependence, wherein the scattering loss L_s within the 200 nm to 2000 nm wavelength range is proportional to λ^{-p} , where p is greater or equal to 0 and less than 2, preferably less than 1, and more preferably less than 0.5 or even more preferably less than 0.3. Another advantageous feature of at least some embodiments of the present invention is the capability of having substantially uniform scattering along the length (e.g., less than 50% and more preferably less than 30% variation from the maximum), and in angular space away from the axis of the fiber, such that forward, 90 degrees (from axis of the fiber) and backward scattering intensities are almost the same (e.g., within 30% of each other, and preferably within 20% of each other).

[0012] In at least some embodiments, the variation of the integrated light intensity coming through sides of the optical fiber (i.e., the intensity variation of the diffused or scattered light) at the illumination wavelength is less than 30% for the target length of the optical fiber.

[0013] In at least some embodiments, the average scattering loss of the fiber is greater than 50 dB/km, and the scattering loss does not vary more than 30% (i.e., the scattering loss is within $\pm 30\%$ of the average scattering loss) over any given fiber segment of 0.2 m length. According to at least some embodiments, the average scattering loss of the fiber is greater than 50 dB/km, and the scattering loss does not vary more than 30% over the fiber segments

of less than 0.05 m length. According to at least some embodiments, the average scattering loss of the fiber is greater than 50 dB/km, and the scattering loss does not vary more than 30% (i.e., $\pm 30\%$) over the fiber segments 0.01 m length.

[0014] One advantageous feature of the fibers according to some embodiments of the present invention and of the illumination system utilising such fibers, is that the fiber acts as a light source, and illuminates the desired medium by uniformly scattering light through the sides of the fiber rather than delivering an intense and localized beam of light from the end of the fiber. Furthermore, in some embodiments, the use of fiber advantageously allows the electrically driven light source to remain distant from the point(s) of light delivery. This fact would be most beneficial in aqueous or potentially explosive environments where the electrical components could be located a safe distance from the conductive or reactive environment.

[0015] It is to be understood that both the foregoing general description and the following detailed description represent embodiments of the invention, and are intended to provide an overview or framework for understanding the nature and character of the invention as it is claimed. The accompanying drawings are included to provide a further understanding of the invention, and are incorporated into and constitute a part of this specification. The drawings illustrate various embodiments of the invention and together with the description serve to explain the principles and operations of the invention.

BRIEF DESCRIPTION OF THE DRAWINGS

[0016] **FIG. 1** is a schematic side view of a section of an example embodiment of light-diffusing optical fiber;

[0017] **FIG. 2** is a schematic cross-section of the optical fiber of **FIG. 1** as viewed along the direction **2-2**;

[0018] **FIG. 3A** is a schematic illustration of relative refractive index plot versus fiber radius for an exemplary embodiment of light diffusing fiber;

[0019] **FIG. 3B** is a schematic illustration of relative refractive index plot versus fiber radius for another exemplary embodiment of light diffusing fiber;

[0020] **FIG. 3C** illustrates another exemplary embodiment of a light diffusing fiber;

[0021] **FIGS. 4A** and **4B** depict fiber attenuation (loss) in dB/m versus wavelength (nm);

[0022] FIG. 5 illustrates a fiber deployment that utilizes two light passes within a single fiber;

[0023] FIG 6A illustrates the intensity distribution along the fiber when the fiber made with uniform tension (example A) and variable tension (example B);

[0024] FIG. 6B illustrates the scattering distribution function with white ink and without ink;

[0025] FIG. 7 illustrates scattering for fiber shown in FIG. 5 (with reflective mirror at coupled to the rear end of the fiber), and also for a fiber utilizing white ink in its coating;

[0026] FIG. 8A illustrates an exemplary embodiment of illumination system;

[0027] FIG. 8B illustrates an example embodiment of illumination system as used in combination with a biological chamber in the form of a flask;

[0028] Additional features and advantages of the invention will be set forth in the detailed description which follows and will be apparent to those skilled in the art from the description or recognized by practicing the invention as described in the following description together with the claims and appended drawings.

DETAILED DESCRIPTION

[0029] Reference is now made in detail to the present preferred embodiments of the invention, examples of which are illustrated in the accompanying drawings. Whenever possible, like or similar reference numerals are used throughout the drawings to refer to like or similar parts. It should be understood that the embodiments disclosed herein are merely examples, each incorporating certain benefits of the present invention.

[0030] Various modifications and alterations may be made to the following examples within the scope of the present invention, and aspects of the different examples may be mixed in different ways to achieve yet further examples. Accordingly, the true scope of the invention is to be understood from the entirety of the present disclosure, in view of but not limited to the embodiments described herein.

Definitions

[0031] Terms such as “horizontal,” “vertical,” “front,” “back,” etc., and the use of Cartesian Coordinates are for the sake of reference in the drawings and for ease of description and are

not intended to be strictly limiting either in the description or in the claims as to an absolute orientation and/or direction.

[0032] In the description of the invention below, the following terms and phrases are used in connection to light diffusing fibers having nano-sized structures.

[0033] The “refractive index profile” is the relationship between the refractive index or the relative refractive index and the waveguide (fiber) radius.

[0034] The “relative refractive index percent” is defined as

$$\Delta(r)\% = 100 \times [n(r)^2 - n_{\text{REF}}^2] / 2n(r)^2,$$

where $n(r)$ is the refractive index at radius r , unless otherwise specified. The relative refractive index percent is defined at 850 nm unless otherwise specified. In one aspect, the reference index n_{REF} is silica glass with the refractive index of 1.452498 at 850 nm, in another aspect is the maximum refractive index of the cladding glass at 850 nm. As used herein, the relative refractive index is represented by Δ and its values are given in units of “%”, unless otherwise specified. In cases where the refractive index of a region is less than the reference index n_{REF} , the relative index percent is negative and is referred to as having a depressed region or depressed-index, and the minimum relative refractive index is calculated at the point at which the relative index is most negative unless otherwise specified. In cases where the refractive index of a region is greater than the reference index n_{REF} , the relative index percent is positive and the region can be said to be raised or to have a positive index.

[0035] An “updopant” is herein considered to be a dopant which has a propensity to raise the refractive index relative to pure undoped SiO_2 . A “downdopant” is herein considered to be a dopant which has a propensity to lower the refractive index relative to pure undoped SiO_2 . An updopant may be present in a region of an optical fiber having a negative relative refractive index when accompanied by one or more other dopants which are not updopants. Likewise, one or more other dopants which are not updopants may be present in a region of an optical fiber having a positive relative refractive index. A downdopant may be present in a region of an optical fiber having a positive relative refractive index when accompanied by one or more other dopants which are not downdopants.

[0036] Likewise, one or more other dopants which are not downdopants may be present in a region of an optical fiber having a negative relative refractive index.

[0037] The term “ α -profile” or “alpha profile” refers to a relative refractive index profile, expressed in terms of $\Delta(r)$ which is in units of “%”, where r is radius, which follows the equation,

$$\Delta(r) = \Delta(r_0)(1 - [|r-r_0| / (r_1-r_0)]^\alpha),$$

where r_0 is the point at which $\Delta(r)$ is maximum, r_1 is the point at which $\Delta(r)\%$ is zero, and r is in the range $r_i \leq r \leq r_f$, where Δ is defined above, r_i is the initial point of the α -profile, r_f is the final point of the α -profile, and α is an exponent which is a real number.

[0038] As used herein, the term “parabolic” therefore includes substantially parabolically shaped refractive index profiles which may vary slightly from an α value of 2.0 at one or more points in the core, as well as profiles with minor variations and/or a centerline dip. In some exemplary embodiments, α is greater than 1.5 and less than 2.5, more preferably greater than 1.7 and 2.3 and even more preferably between 1.8 and 2.3 as measured at 850 nm. In other embodiments, one or more segments of the refractive index profile have a substantially step index shape with an α value greater than 8, more preferably greater than 10 even more preferably greater than 20 as measured at 850 nm.

[0039] The term “nano-structured fiber region” describes the fiber having a region or area with a large number (greater than 50) of gas filled voids, or other nano-sized structures, e.g., more than 50, more than 100, or more than 200 voids in the cross-section of the fiber. The gas filled voids may contain, for example, SO_2 , Kr, Ar, CO_2 , N_2 , O_2 , or mixture thereof. The cross-sectional size (e.g., diameter) of nano-sized structures (e.g., voids) as described herein may vary from 10 nm to 1 μm (for example, 50 nm-500 nm), and the length may vary from 1 millimeter to 50 meters (e.g., 2 mm to 5 meters, or 5 mm to 1 m range).

[0040] In standard single mode or multimode optical fibers, the losses at wavelengths less than 1300 nm are dominated by Rayleigh scattering. These Rayleigh scattering loss L_s is determined by the properties of the material and are typically about 20 dB/km for visible wavelengths (400-700 nm). Rayleigh scattering losses also have a strong wavelength dependence (i.e., $L_s \propto 1/\lambda^4$, see FIG 4B, comparative fiber A), which means that at least about 1 km to 2 km of the fiber is needed to dissipate more than 95% of the input light. Shorter lengths of such fiber would result in lower illumination efficiency, while using long lengths (1 km to 2 km, or more) can be more costly and can be difficult to manage. The long lengths of fiber, when used in a bioreactor or other illumination system may be cumbersome to install.

[0041] In certain configurations of lighting applications it is desirable to use shorter lengths of fiber, for example, 1-100 meters. This requires an increase of scattering loss from the fiber, while being able to maintain good angular scattering properties (uniform dissipation of light away from the axis of the fiber) and good bending performance to avoid bright spots at fiber bends. A desirable attribute of at least some of the embodiments of present invention described herein is uniform and high illumination along the length of the fiber illuminator. Because the optical fiber is flexible, it allows a wide variety of the illumination shapes to be deployed. It is preferable to have no bright spots (due to elevated bend losses) at the bending points of the fiber, such that the illumination provided by the fiber does not vary by more than 30%, preferably less than 20% and more preferably less than 10%. For example, in at least some embodiments, the average scattering loss of the fiber is greater than 50 dB/km, and the scattering loss does not vary more than 30% (i.e., the scattering loss is within $\pm 30\%$ of the average scattering loss) over any given fiber segment of 0.2 m length. According to at least some embodiments, the average scattering loss of the fiber is greater than 50 dB/km, and the scattering loss does not vary more than 30% over the fiber segments of less than 0.05 m length. According to at least some embodiments, the average scattering loss of the fiber is greater than 50 dB/km, and the scattering loss does not vary more than 30% (i.e., $\pm 30\%$) over the fiber segments 0.01 m length. According to at least some embodiments, the average scattering loss of the fiber is greater than 50 dB/km, and the scattering loss does not vary more than 20% (i.e., $\pm 20\%$) and preferably by not more than 10% (i.e., $\pm 10\%$) over the fiber segments 0.01 m length.

[0042] In at least some embodiments, the intensity variation of the integrated (diffused) light intensity coming through sides of the fiber at the illumination wavelength is less than 30% for target length of the fiber, which can be, for example, 0.02- 100 m length. It is noted that the intensity of integrated light intensity through sides of the fiber at a specified illumination wavelength can be varied by incorporating fluorescence material in the cladding or coating. The wavelength of the light scattering by the fluorescent material is different from the wavelength of the light propagating in the fiber.

[0043] In some the following exemplary embodiments we describe fiber designs with a nano-structured fiber region (region with nano-sized structures) placed in the core area of the fiber, or very close to core. Some of the fiber embodiments have scattering losses in excess of 50 dB/km (for example, greater than 100 dB/km, greater than 200 dB/km, greater than 500

dB/km, greater than 1000 dB/km, greater than 3000 dB/km, greater than 5000 dB/km), the scattering loss (and thus illumination, or light radiated by these fibers) is uniform in angular space.

[0044] In order to reduce or to eliminate bright spots as bends in the fiber, it is desirable that the increase in attenuation at a 90° bend in the fiber is less than 5 dB/turn (for example, less than 3 dB/turn, less than 2 dB/turn, less than 1 dB/turn) when the bend diameter is less than 50 mm. In exemplary embodiment, these low bend losses are achieved at even smaller bend diameters, for example, less than 20 mm, less than 10 mm, and even less than 5 mm.

Preferably, the total increase in attenuation is less than 1 dB per 90 degree turn at a bend radius of 5 mm.

[0045] Preferably, according to some embodiments, the bending loss is equal to or is lower than intrinsic scattering loss from the core of the straight fiber. The intrinsic scattering is predominantly due to scattering from the nano-sized structures. Thus, according to at least the bend insensitive embodiments of optical fiber, the bend loss does not exceed the intrinsic scattering for the fiber. However, because the scattering level is a function of bending diameter, the bending deployment of the fiber depends on its scattering level. For example, in some of the embodiments, the fiber has a bend loss less than 3 dB/turn, preferably less than 2 dB/turn, and the fiber can be bent in an arc with a radius as small as 5 mm radius without forming bright spots.

[0046] **FIG. 1** is a schematic side view of a section of an example embodiment of a light diffusing fiber with a plurality of voids in the core of the light diffusing optical fiber (hereinafter “fiber”) **12** having a central axis (“centerline”) **16**. **FIG. 2** is a schematic cross-section of light diffusing optical fiber **12** as viewed along the direction **2-2** in **FIG. 1**. Light diffusing fiber **12** can be, for example, any one of the various types of optical fiber with a nano-structured fiber region having periodic or non-periodic nano-sized structures **32** (for example voids). In an example embodiment, fiber **12** includes a core **20** divided into three sections or regions. These core regions are: a solid central portion **22**, a nano-structured ring portion (inner annular core region) **26**, and outer, solid portion **28** surrounding the inner annular core region **26**. A cladding region **40** (“cladding”) surrounds the annular core **20** and has an outer surface. The cladding **40** may have low refractive index to provide a high numerical aperture (NA). The cladding **40** can be, for example, a low index polymer such as UV or thermally curable fluoroacrylate or silicone.

[0047] An optional coating **44** surrounds the cladding **40**. Coating **44** may include a low modulus primary coating layer and a high modulus secondary coating layer. In at least some embodiments, coating layer **44** comprises a polymer coating such as an acrylate-based or silicone based polymer. In at least some embodiments, the coating has a constant diameter along the length of the fiber.

[0048] In other exemplary embodiments described below, coating **44** is designed to enhance the distribution and/or the nature of “radiated light” that passes from core **20** through cladding **40**. The outer surface of the cladding **40** or the of the outer of optional coating **44** represents the “sides” **48** of fiber **12** through which light traveling in the fiber is made to exit via scattering, as described herein.

[0049] A protective cover or sheath (not shown) optionally covers cladding **40**. Fiber **12** may include a fluorinated cladding **40**, but the fluorinated cladding is not needed if the fibers are to be used in short-length applications where leakage losses do not degrade the illumination properties.

[0050] In some exemplary embodiments, the core region **26** of light diffusing fiber **12** comprises a glass matrix (“glass”) **31** with a plurality of non-periodically disposed nano-sized structures (e.g., “voids”) **32** situated therein, such as the example voids shown in detail in the magnified inset of **FIG. 2**. In another example embodiment, voids **32** may be periodically disposed, such as in a photonic crystal optical fiber, wherein the voids typically have diameters between about 1×10^{-6} m and 1×10^{-5} m. Voids **32** may also be non-periodically or randomly disposed. In some exemplary embodiment, glass **31** in region **26** is fluorine-doped silica, while in other embodiment the glass is undoped pure silica. Preferably the diameters of the voids are at least 10 nm.

[0051] The nano-sized structures **32** scatter the light away from the core **20** and toward the outer surface of the fiber. The scattered light is then “diffused” through of the outer surface of the fiber **12** to provide the desired illumination. That is, most of the light is diffused (via scattering) through the sides of the fiber **12**, along the fiber length. Preferably, the fiber emits substantially uniform radiation over its length, and the fiber has a scattering-induced attenuation of greater than 50 dB/km in the wavelength(s) of the emitted radiation (illumination wavelength). Preferably, the scattering-induced attenuation is greater than 100 dB/km for this wavelength. In some embodiments, the scattering-induced attenuation is greater than 500 dB/km for this wavelength, and in some embodiments is 1000 dB/km, greater

than 2000 dB/km, and greater than 5000 dB/km. These high scattering losses are about 2.5 to 250 times higher than the Rayleigh scattering losses in standard single mode and multimode optical fibers.

[0052] Glass in core regions **22** and **28** may include up dopants, such as Ge, Al, and/or P. By “non-periodically disposed” or “non-periodic distribution,” it is meant that when one takes a cross-section of the optical fiber (such as shown in **FIG. 2**), the voids **32** are randomly or non-periodically distributed across a portion of the fiber. Similar cross sections taken at different points along the length of the fiber will reveal different cross-sectional void patterns, i.e., various cross sections will have different voids patterns, wherein the distributions of voids and sizes of voids do not match. That is, the voids are non-periodic, i.e., they are not periodically disposed within the fiber structure. These voids are stretched (elongated) along the length (i.e. parallel to the longitudinal axis) of the optical fiber, but do not extend the entire length of the entire fiber for typical lengths of transmission fiber. While not wishing to be bound by theory, it is believed that the voids extend less than 10 meters, and in many cases less than 1 meter along the length of the fiber.

[0053] The light diffusing fiber **12** as used herein in the illumination system discussed below can be made by methods which utilize preform consolidation conditions which result in a significant amount of gases being trapped in the consolidated glass blank, thereby causing the formation of voids in the consolidated glass optical fiber preform. Rather than taking steps to remove these voids, the resultant preform is used to form an optical fiber with voids, or nano-sized structures, therein. The resultant fiber’s nano-sized structures or voids are utilized to scatter or guide the light out of the fiber, via its sides, along the fiber length. That is, the light is guided away from the core **20**, through the outer surface of the fiber, to provide the desired illumination.

[0054] As used herein, the diameter of a nano-sized structure such as void is the longest line segment whose endpoints a) when the optical fiber is viewed in perpendicular cross-section transverse to the longitudinal axis of the fiber. Method of making optical fibers with nano-sized voids is described, for example, in U.S. Patent Application Serial No. 11/583,098, which is incorporated herein by reference.

[0055] As described above, in some embodiments of fiber **12**, core sections **22** and **28** comprise silica doped with germanium, i.e., germania-doped silica. Dopants other than germanium, singly or in combination, may be employed within the core, and particularly at or

near the centerline **16**, of the optical fiber to obtain the desired refractive index and density. In at least some embodiments, the relative refractive index profile of the optical fiber disclosed herein is non-negative in sections **22** and **28**. These dopants may be, for example, Al, Ti, P, Ge, or a combination thereof. In at least some embodiments, the optical fiber contains no index-decreasing dopants in the core. In some embodiments, the relative refractive index profile of the optical fiber disclosed herein is non-negative in sections **22**, **24** and **28**.

[0056] In some examples of fiber **12** as used herein, the core **20** comprises pure silica. In one embodiment, a preferred attribute of the fiber is the ability to scatter light out of the fiber (to diffuse light) in the desired spectral range to which biological material is sensitive. In another embodiment, the scattered light may be used for decorative accents and white light applications. The amount of the loss via scattering can be increased by changing the properties of the glass in the fiber, the width of the nano-structured region **26**, and the size and the density of the nano-sized structures.

[0057] In some examples of fiber **12** as used herein, core **20** is a graded-index core, and preferably, the refractive index profile of the core has a parabolic (or substantially parabolic) shape; for example, in some embodiments, the refractive index profile of core **20** has an α -shape with an α value of about 2, preferably between 1.8 and 2.3 as measured at 850 nm. In other embodiments, one or more segments of the refractive index profile have a substantially step index shape with an α value greater than 8, more preferably greater than 10 even more preferably greater than 20 as measured at 850 nm. In some embodiments, the refractive index of the core may have a centerline dip, wherein the maximum refractive index of the core, and the maximum refractive index of the entire optical fiber, is located a small distance away from centerline **16**, but in other embodiments the refractive index of the core has no centerline dip, and the maximum refractive index of the core, and the maximum refractive index of the entire optical fiber, is located at the centerline.

[0058] In an exemplary embodiment, fiber **12** has a silica-based core **20** and depressed index (relative to silica) polymer cladding **40**. The low index polymer cladding **40** preferably has a relative refractive index that is negative, more preferably less than -0.5% and even more preferably less than -1% . In some exemplary embodiments cladding **40** has thickness of 20 μm or more. In some exemplary embodiments cladding **40** has a lowered refractive index than the core, and a thickness of 10 μm or more (e.g., 20 μm or more). In some exemplary embodiments, the cladding has an outer diameter 2 times R_{max} , e.g., of about 125 μm (e.g.,

120 μm to 130 μm , or 123 μm to 128 μm). In other embodiments the cladding has the diameter that is less than 120 μm , for example 60 or 80 μm . In other embodiments the outer diameter of the cladding is greater than 200 μm , greater than 300 μm , or greater than 500 μm . In some embodiments, the outer diameter of the cladding has a constant diameter along the length of fiber **12**. In some embodiments, the refractive index of fiber **12** has radial symmetry. Preferably, the outer diameter **2R3** of core **20** is constant along the length of the fiber.

Preferably the outer diameters of core sections **22**, **26**, **28** are also constant along the length of the fiber. By constant, we mean that the variations in the diameter with respect to the mean value are less than 10%, preferably less than 5% and more preferably less than 2%. **FIG. 3A** is a plot of the exemplary relative refractive index Δ versus fiber radius for an example fiber **12** shown in **FIG. 2** (solid line). The core **20** may also have a graded core profile, with α -profile having, for example, α -value between 1.8 and 2.3 (e.g., 1.8 to 2.1).

[0059] **FIG. 3A** is a plot of the exemplary relative refractive index Δ versus fiber radius for an example fiber **12** shown in **FIG. 2** (solid line). The core **20** may also have a graded core profile, characterized, for example, by an α -value between 1.7 and 2.3 (e.g., 1.8 to 2.3). An alternative exemplary refractive index profile is illustrated by the dashed lines. Core region **22** extends radially outwardly from the centerline to its outer radius, **R1**, and has a relative refractive index profile $\Delta_1(r)$ corresponding to a maximum refractive index n_1 (and relative refractive index percent $\Delta_{1\text{MAX}}$). In this embodiment, the reference index n_{REF} is the refractive index at the cladding. The second core region (nano-structured region) **26** has minimum refractive index n_2 , a relative refractive index profile $\Delta_2(r)$, a maximum relative refractive index $\Delta_{2\text{MAX}}$, and a minimum relative refractive index $\Delta_{2\text{MIN}}$, where in some embodiments $\Delta_{2\text{MAX}} = \Delta_{2\text{MIN}}$. The third core region **28** has a maximum refractive index n_3 , a relative refractive index profile $\Delta_3(r)$ with a maximum relative refractive index $\Delta_{3\text{MAX}}$ and a minimum relative refractive index $\Delta_{3\text{MIN}}$, where in some embodiments $\Delta_{3\text{MAX}} = \Delta_{3\text{MIN}}$. In this embodiment the annular cladding **40** has a refractive index n_4 , a relative refractive index profile $\Delta_4(r)$ with a maximum relative refractive index $\Delta_{4\text{MAX}}$, and a minimum relative refractive index $\Delta_{4\text{MIN}}$. In some embodiments $\Delta_{4\text{MAX}} = \Delta_{4\text{MIN}}$. In some embodiments, $\Delta_{1\text{MAX}} > \Delta_{4\text{MAX}}$ and $\Delta_{3\text{MAX}} > \Delta_{4\text{MAX}}$. In some embodiments $\Delta_{2\text{MIN}} > \Delta_{4\text{MAX}}$. In the embodiment shown in **FIGs. 2** and **3A**, $\Delta_{1\text{MAX}} > \Delta_{3\text{MAX}} > \Delta_{2\text{MAX}} > \Delta_{4\text{MAX}}$. In this embodiment the refractive indices of the regions have the following relationship $n_1 > n_3 > n_2 > n_4$.

[0060] In some embodiments, core regions **22**, **28** have a substantially constant refractive index profile, as shown in **FIG. 3A** with a constant $\Delta 1(r)$ and $\Delta 3(r)$. In some of these embodiments, $\Delta 2(r)$ is either slightly positive ($0 < \Delta 2(r) < 0.1\%$), negative ($-0.1\% < \Delta 2(r) < 0$), or 0% . In some embodiments the absolute magnitude of $\Delta 2(r)$ is less than 0.1% , preferably less than 0.05% . In some embodiments, the outer cladding region **40** has a substantially constant refractive index profile, as shown in **FIG. 3A** with a constant $\Delta 4(r)$. In some of these embodiments, $\Delta 4(r) = 0\%$. The core section **22** has a refractive index where $\Delta 1(r) \geq 0\%$. In some embodiments, the void-filled region **26** has a relative refractive index profile $\Delta 2(r)$ having a negative refractive index with absolute magnitude less than 0.05% , and $\Delta 3(r)$ of the core region **28** can be, for example, positive or zero. In at least some embodiments, $n_1 > n_2$ and $n_3 > n_4$.

[0061] In some embodiments the cladding **40** has a refractive index $-0.05\% < \Delta 4(r) < 0.05\%$. In other embodiments, the cladding **40** and the core portions portion **20**, **26**, and **28** may comprise pure (undoped) silica.

[0062] In some embodiments, the cladding **40** comprises pure or F-doped silica. In some embodiments, the cladding **40** comprises pure low index polymer. In some embodiments, nano-structured region **26** comprises pure silica comprising a plurality of voids **32**. Preferably, the minimum relative refractive index and the average effective relative refractive index, taking into account the presence of any voids, of nano-structured region **26** are both less than -0.1% . The voids or voids **32** may contain one or more gases, such as argon, nitrogen, oxygen, krypton, or SO_2 or can contain a vacuum with substantially no gas. However, regardless of the presence or absence of any gas, the average refractive index in nano-structured region **26** is lowered due to the presence of voids **32**. Voids **32** can be randomly or non-periodically disposed in the nano-structured region **26**, and in other embodiments, the voids are disposed periodically therein.

[0063] In some embodiments, the plurality of voids **32** comprises a plurality of non-periodically disposed voids and a plurality of periodically disposed voids.

[0064] In example embodiments, core section **22** comprises germania doped silica, core inner annular region **28** comprises pure silica, and the cladding annular region **40** comprises a glass or a low index polymer. In some of these embodiments, nano-structured region **26** comprises a plurality of voids **32** in pure silica; and in yet others of these embodiments, nano-structured region **26** comprises a plurality of voids **32** in fluorine-doped silica.

[0065] In some embodiments, the outer radius, R_c , of core is greater than 10 μm and less than 600 μm . In some embodiments, the outer radius R_c of core is greater than 30 μm and/or less than 400 μm . For example, R_c may be 125 μm to 300 μm . In other embodiments, the outer radius R_c of the core **20** (please note that in the embodiment shown in **FIG. 3A**, $R_c = R_3$) is larger than 50 μm and less than 250 μm . The central portion **22** of the core **20** has a radius in the range $0.1R_c \leq R_1 \leq 0.9R_c$, preferably $0.5R_c \leq R_1 \leq 0.9R_c$. The width W_2 of the nano-structured ring region **26** is preferably $0.05R_c \leq W_2 \leq 0.9R_c$, preferably $0.1R_c \leq W_2 \leq 0.9R_c$, and in some embodiments $0.5R_c \leq W_2 \leq 0.9R_c$ (a wider nano-structured region gives a higher scattering-induced attenuation, for the same density of nano-sized structures). The solid glass core region **28** has a width $W_s = W_3$ such that $0.1R_c > W_3 > 0.9R_c$. Each section of the core **20** comprises silica based glass. The radial width W_2 of nano-structured region **26** is preferably greater than 1 μm . For example, W_2 may be 5 μm to 300 μm , and preferably 200 μm or less. In some embodiments, W_2 is greater than 2 μm and less than 100 μm . In other embodiments, W_2 is greater than 2 μm and less than 50 μm . In other embodiments, W_2 is greater than 2 μm and less than 20 μm . In some embodiments, W_2 is at least 7 μm . In other embodiments, W_2 is greater than 2 μm and less than 12 μm . The width W_3 of core region **28** is $(R_3 - R_2)$ and its midpoint $R_{3\text{MID}}$ is $(R_2 + R_3)/2$. In some embodiments, W_3 is greater than 1 μm and less than 100 μm .

[0066] The numerical aperture (NA) of fiber **12** is preferably equal to or greater than the NA of a light source directing light into the fiber. Preferably the numerical aperture (NA) of fiber **12** is greater than 0.2, in some embodiments greater than 0.3, and even more preferably greater than 0.4.

[0067] In some embodiments, the core outer radius R_1 of the first core region **22** is preferably not less than 24 μm and not more than 50 μm , i.e. the core diameter is between about 48 and 100 μm . In other embodiments, $R_1 > 24$ microns; in still other embodiments, $R_1 > 30$ microns; in yet other embodiments, $R_1 > 40$ microns.

[0068] In some embodiments, $|\Delta_2(r)| < 0.025\%$ for more than 50% of the radial width of the annular inner portion **26**, and in other embodiments $|\Delta_2(r)| < 0.01\%$ for more than 50% of the radial width of region **26**. The depressed-index annular portion **26** begins where the relative refractive index of the cladding first reaches a value of less than -0.05%, going radially outwardly from the centerline. In some embodiments, the cladding **40** has a relative refractive index profile $\Delta_4(r)$ having a maximum absolute magnitude less than 0.1%, and in this

embodiment $\Delta 4_{\text{MAX}} < 0.05\%$ and $\Delta 4_{\text{MIN}} > -0.05\%$, and the depressed-index annular portion **26** ends where the outermost void is found.

[0069] Cladding structure **40** extends to a radius **R4**, which is also the outermost periphery of the optical fiber. In some embodiments, the width of the cladding, R4-R3, is greater than 20 μm ; in other embodiments R4-R3 is at least 50 μm , and in some embodiments, R4-R3 is at least 70 μm .

[0070] In another embodiment, the entire core **20** is nano-structured (filled with voids, for example), and the core **20** is surrounded by the cladding **40**. The core **20** may have a “step” refractive index delta, or may have a graded core profile, with α -profile having, for example, α -value between 1.8 and 2.3.

[0071] Preparation of optical preform and fibers for examples shown in **Figures 3C, 4A and 6-8** were as follows: In this exemplary embodiment, 470 grams of SiO_2 (0.5 g/cc density) soot were deposited via outside vapor deposition (OVD) onto a fully consolidated 1 meter long, 20 mm diameter pure silica void-free core cane, resulting in a preform assembly (sometimes referred to as a preform, or an optical preform) comprising a consolidated void-free silica core region which was surrounded by a soot silica region. The soot cladding of this preform assembly was then sintered as follows. The preform assembly was first dried for 2 hours in an atmosphere comprising helium and 3 percent chlorine (all percent gases by volume) at 1100°C in the upper-zone part of the furnace, followed by down driving at 200 mm/min (corresponding to approximately a 100°C/min temperature increase for the outside of the soot preform during the downdrive process) through a hot zone set at approximately 1500°C in a 100 percent SO_2 (by volume) sintering atmosphere. The preform assembly was then down driven again (i.e., a second time) through the hot zone at the rate of 100 mm/min (corresponding to an approximately 50°C/min temperature increase for the outside of the soot preform during the downdrive process). The preform assembly was then down driven again (i.e., a third time) through the hot zone at the rate of 50 mm/min (corresponding to an approximately 25°C/min temperature increase for the outside of the soot preform during the downdrive process). The preform assembly was then down driven again (i.e., a fourth time) through the hot zone at the rate of 25 mm/min (corresponding to an approximately 12.5°C/min temperature increase for the outside of the soot preform during the downdrive process), then finally sintered at 6 mm/min (approximately 3°C/min heat up rate) in order to sinter the soot into an SO_2 -seeded silica overlaid preform. Following each downdrive step, the preform

assembly was updriven at 200 mm/min into the upper-zone part of the furnace (which remained set at 1100°C). The first series of higher downfeed rate are employed to glaze the outside of the optical fiber preform, which facilitates trapping of the gases in the preform. The preform was then placed for 24 hours in an argon purged holding oven set at 1000°C to outgas any remaining helium in the preform. This preform was then redrawn in an argon atmosphere on a conventional graphite redraw furnace set at approximately 1700°C into void-free SiO₂ core, SO₂-seeded (i.e., containing the non-periodically located voids containing SO₂ gas) silica overclad canes which were 10 mm in diameter and 1 meter long.

[0072] One of the 10 mm canes was placed back in a lathe where about 190 grams of additional SiO₂ (0.52 g/cc density) soot was deposited via OVD. The soot of this cladding (which may be called overcladding) for this assembly was then sintered as follows. The assembly was first dried for 2 hours in an atmosphere consisting of helium and 3 percent chlorine at 1100°C followed by down driving at 5 mm/min through a hot zone set at 1500°C in a 100 % helium (by volume) atmosphere in order to sinter the soot to a germania containing void-free silica core, silica SO₂-seeded ring (i.e. silica with voids containing SO₂), and void-free overclad preform. The preform was placed for 24 hours in an argon purged holding oven set at 1000°C to outgas any remaining helium from the preform. The optical fiber preform was drawn to 3 km lengths of 125 micron diameter optical fiber at approximately 1900°C to 2000°C in a helium atmosphere on a graphite resistance furnace. The temperature of the optical preform was controlled by monitoring and controlling the optical fiber tension; in this embodiment the fiber tension was held at one value between 30 and 600 grams during each portion (e.g., 3 km lengths) of a fiber draw run. The fiber was coated with a low index silicon based coating during the draw process.

[0073] Another 10 mm void-free silica core SO₂-seeded silica overclad canes described above (i.e., a second cane) was utilized to manufacture the optical preform and fibers for examples shown in **Figure 4B**. More specifically, the second 10 mm void-free silica core SO₂-seeded silica overclad cane was placed back in a lathe where about 3750 grams of additional SiO₂ (0.67 g/cc density) soot are deposited via OVD. The soot of this cladding (which may be called overcladding for this assembly) was then sintered as follows. The assembly was first dried for 2 hours in an atmosphere comprising of helium and 3 percent chlorine at 1100°C, followed by down driving at 5 mm/min through a hot zone set at 1500°C in a 100 % helium (by volume) atmosphere in order to sinter the soot so as to produce

preform comprising germania containing void-free silica core, silica SO₂-seeded ring (i.e. silica with voids containing SO₂), and void-free overclad. The resultant optical fiber preform was placed for 24 hours in an argon purged holding oven set at 1000°C to outgas any remaining helium from the preform. Finally, the optical fiber preform was drawn to 5 km lengths of 125 micron diameter optical fiber and coated with the low index polymer as described above.

[0074] FIG. 3B illustrates schematically yet another exemplary embodiment of light diffusing fiber 12. The fiber of FIG. 3B includes a core 20 with a relative refractive index Δ_1 , a nano-structured region 26' situated over and surrounding the core 20. The core 20 may have a "step" index profile, or a graded core profile, with α -profile having, for example, α -value between 1.8 and 2.3.

[0075] In this exemplary embodiment (see Fig. 3B) the nano-structured region 26' is an annular ring with a plurality of voids 32. In this embodiment, the width of region 26' can be as small as 1-2 μm , and may have a negative average relative refractive index Δ_2 . Cladding 40 surrounds the nano-structured region 26'. The (radial) width of cladding 40 may be as small as 1 μm , and the cladding may have either a negative, a positive or 0% relative refractive index, (relative to pure silica). The main difference between examples in FIGs. 3A and 3B is that nano-structured region in shown in FIG. 3A is located in the core 20 of the light diffusing fiber 12, and in FIG. 3B it is located at the core/clad interface. The depressed-index annular portion 26' begins where the relative refractive index of the core first reaches a value of less than -0.05%, going radially outwardly from the centerline. In the embodiment of FIG. 3B, the cladding 40 has a relative refractive index profile $\Delta_3(r)$ having a maximum absolute magnitude less than 0.1%, and in this embodiment $\Delta_{3\text{MAX}} < 0.05\%$ and $\Delta_{3\text{MIN}} > -0.05\%$, and the depressed-index annular portion 26 ends where the outmost void occurs in the void-filled region.

[0076] In the embodiment shown in FIG. 3B the index of refraction of the core 20 is greater than the index of refraction n_2 of the annular region 26', and the index of refraction n_1 of the cladding 40 is also greater than the index of refraction n_2 .

FIG. 3C illustrates a core 20 of one embodiment of an optical fiber 12 that has been made. This fiber has a first core region 22 with an outer radius R_1 of about 33.4 μm , a nano-structured region 26 with an outer radius $R_2 = 42.8 \mu\text{m}$, a third core region 28 with an outer radius $R_3 = 62.5 \mu\text{m}$, and a polymer cladding 40 with an outer radius R_4 (not shown) of 82.5 μm . In this embodiment, the material of the core is pure silica (undoped silica), the material

for cladding was low index polymer (e.g., UV curable silicone having a refractive index of 1.413 available from Dow-Corning of Midland, Michigan under product name Q3-6696) which, in conjunction with the glass core, resulted in fiber NA of 0.3. The optical fiber **12** had a relatively flat (weak) dependence on wavelength, compared to standard single-mode transmission fiber, such as for example SMF-28e^R fiber, **FIG. 4B**. In standard single mode (such as SMF-28^R) or multimode optical fibers, the losses at wavelengths less than 1300 nm are dominated by Rayleigh scattering. These Rayleigh scattering losses are determined by the properties of the material and are typically about 20 dB/km for visible wavelengths (400-700 nm). The wavelength dependence of Rayleigh scattering losses is proportional to λ^{-p} with $p \approx 4$. The exponent of the wavelength dependent scattering losses in the fiber comprising at least one nanostructured region is less than 2, preferably less than 1 over at least 80% (for example greater than 90%) in the 400 nm-1100 nm wavelength range. The average spectral attenuation from 400 nm to 1100 nm was about 0.4 dB/m when the fiber was drawn with at 40 g tension and was about 0.1 dB/m when the fiber **12** was drawn at 90 g tension. In this embodiment, the nano-sized structures contain SO₂ gas. Applicants found that filled SO₂ voids in the nano-structured ring greatly contribute to scattering. Furthermore, when SO₂ gas was used to form the nano-structures, it has been discovered that this gas allows a thermally reversible loss to be obtained, i.e., below 600 °C the nano-structured fiber scatters light, but above 600 °C the same fiber will guide light. This unique behavior that SO₂ imparts is also reversible, in that upon cooling the same fiber below 600 °C, the fiber **12** will act as light diffusing fiber and will again generate an observable scattering effect.

[0077] In preferred embodiments, the uniformity of illumination along the fiber length is controlled such that the minimum scattering illumination intensity is not less than 0.7 of the maximum scattering illumination intensity, by controlling fiber tension during the draw process.

[0078] The presence of the nano-sized structures in the light diffusing fiber **12** creates losses due to optical scattering, and the light scattering through the outer surface of the fiber can be used for illumination purposes. **FIG. 4A** is a plot of the attenuation (loss) in dB/m versus wavelength (nm) for the fiber of **FIG. 3C** (fiber with SO₂ gas filled voids). **FIG. 4A** illustrates that (i) light diffusing fibers **12** can achieve very large scattering losses (and thus can provide high illumination intensity) in the visible wavelength range. The scattering losses of the optical fiber **12** also have weak wavelength dependence (L_s is proportional to $1/\lambda^p$, where p is less

than 2, preferably less than 1, and even more preferably less than 0.5), as compared to regular 125 μm graded index core multi mode comparative fiber A (fiber A is a step index multimode fiber without the nano-structured region) which has Rayleigh scattering losses of about 0.02 dB/m in the visible wavelength range, or about 20 dB/km at the wavelength of 500 nm and relatively strong wavelength dependence of $1/\lambda^4$). The effect of the tension for the fibers **12** is also illustrated in **FIGs. 4A-4B**. More specifically **FIGs. 4A-4B** illustrate that the higher fiber draw tension results in lower scattering losses, and that lower fiber draw tension results in a fiber section with higher scattering loss, i.e., stronger illumination). **Fig. 4A** depicts attenuation as function of wavelength for light diffusing fiber **12** (with voids in the core) drawn at different fiber tensions of 90 and 400 g. **Fig. 4B** depicts attenuation as function of wavelength for different light diffusing fiber **12** (with voids in the core) drawn at different fiber tension, 90 and 40 g, a comparative multi mode fiber (fiber A) with normalized loss, and a theoretical fiber with $1/\lambda$ loss dependence. (Note, **Fig. 4B** graph describes wavelength dependence of the loss. In this example, in order to compare the slope of the scattering for the light fiber **12** and fiber A, the loss of low loss fiber (fiber A) was multiplied by a factor of 20, so that the two plots can be easily shown on the same figure.) Without being bound to any particular theory, it is believed that the increase in the scattering losses when the draw tension decreases, for example from 90g to 40g, is due to an increase in the average diameter of the nanostructures. Therefore, this effect of fiber tension could be used to produce constant attenuation (illumination intensity) along the length of the fiber by varying the fiber tension during the draw process. For example, a first fiber segment drawn at high tension, T_1 , with a loss of α_1 dB/m and length, L_1 , will attenuate the optical power from an input level P_0 to $P_0 \exp(-\alpha_1 * L_1 / 4.343)$. A second fiber segment optically coupled to the first fiber segment and drawn at lower tension T_2 with a loss of α_2 dB/m and length L_2 will further attenuate the optical power from $P_0 \exp(-\alpha_1 * L_1 / 4.343)$ to $P_0 \exp(-\alpha_1 * L_1 / 4.343) \exp(-\alpha_2 * L_2 / 4.343)$. The lengths and attenuations of the first and second fiber segments can be adjusted to provide uniform intensity along the length of the concatenated fiber.

[0079] One of the advantages of light diffusing fibers **12** is their ability to provide uniform illumination along the length of the light diffusing fiber. **FIG. 5** illustrates the arrangement of fiber **12** that results in uniform illumination along the length of the fiber and utilizes two light passes in the single light diffusing fiber **12**. In this arrangement a mirror **M** is placed at the end of the light diffusing fiber **12**. The input light provided by the light source **150** to the light

diffusing fiber **12** propagates along the axis of the light diffusing fiber **12**, and the remaining light is reflected by the mirror and propagates back along the axis of the fiber **12** towards the input. If the attenuation and length of the fiber **12** are chosen properly, the light output power provided back to the light source is less than a 2%-5% percent of the original light power. The scattering loss intensity for fiber with constant loss distribution (see **FIG. 4A**) may be higher in the beginning of the fiber and weaker at the end of the fiber. However, if the light diffusing fiber **12** is drawn with a periodically controlled tension (the tension value is related to the furnace temperature, which may vary from 1800 °C to 2100 °C) such that the scattering losses are lower at the beginning of the fiber, where the intensity is high, and higher at the end, where the intensity is lower, the resulting scattering intensity can be made less variable, or constant (for example, as shown in **FIG. 6A**, example C). The fiber draw tension may be controlled and varied, for example, between 40 g and 400 g, thus providing a wide range of scattering-induced attenuation (e.g., up to 6 times). The mirror M in **FIG. 5** may also be replaced by a second light source with power density output that similar to that of the first light source (within a factor of 2, i.e., in the range of 50% to 200%) to not only create a more uniform illumination, but also to increase the quantity of light scattered by the fiber.

[0080] One aspect of an exemplary embodiment of the bioreactor/illumination system is that the angular distribution of the scattering light intensity is uniform or nearly uniform in angular space. The light scattering axially from the surface of the fiber has a variation relative to the mean scattering intensity that is less than 50%, preferably less than 30%, preferably less than 20% and more preferably less than 10%. The dominant scattering mechanism in conventional silica-based optical fibers without nano-sized structures is Rayleigh scattering, which has a broad angular distribution. Fibers **12** in which there are additional scattering losses due to voids in nano-structured ring may have a strong forward component, as shown in **FIG. 6A** (embodiments a and b) and **FIG. 6B** (embodiment a'). This distribution, however, can be corrected by placing a scattering material on the top of coating of the light diffusing fiber **12**. Light diffusing fibers made with coating containing TiO₂ based white ink (see **FIG. 6B**, embodiment b') provide an angular distribution of scattered light that is significantly less forward biased. With an additional thicker layer of TiO₂ ink (e.g., 1-5 μm) it is possible to further reduce the forward scattering component, thereby increasing the uniformity of the angular intensity distribution. However, as shown in **FIG. 7**, if the illuminator design may utilize fiber(s) optically coupled to a back reflective mirror or additional light source (see **FIG.**

5), so even if the fiber has no TiO₂ based white ink coating layer this configuration provides relatively flat (i.e., very uniform) angular scattering intensity (see **FIG. 6A**). In some embodiments, a controlled variation of the ink coating (either thickness of the ink coating or variation of ink concentration in the coating) along the length of the fiber will provide an additional way of making more uniform variation in the intensity of the light scattered from the fiber at large angles (more than 15 degrees).

[0081] In some embodiments the ink can be a fluorescent material that converts scattered light to a longer wavelength of light. In some embodiments white light can be emitted (diffused out of the outer surface) by the fiber **12** by coupling the light diffusing fiber **12** with such a coating to a UV light source, for example a 405 nm or 445 nm diode laser. The angular distribution of fluorescence white light in the exemplary embodiments is substantially uniform (e.g., 25% to 400%, preferably 50% to 200%, even more preferably 50% to 150%, or 70% to 130%, or 80% to 120% in angular space).

Lighting system configuration

[0082] Efficient coupling to low cost light sources such as light emitting diodes (LEDs) or sunlight requires the fiber to have a high NA and large core diameter. With a design similar to that shown in **FIG. 2** the size of the multimode core **20** can be maximized, and may have a radius up to 500 μm. The cladding thickness may be much smaller, for example, about 15-30 μm (e.g., about 20 μm). For example, according to one embodiment, a plurality of light diffusing fibers **12** may be wound around a support structure, and each light diffusing optical fiber may be optically coupled to either the light source or a plurality of light sources. The plurality of light diffusing optical fibers **12** can be bundled together in at least one of: a ribbon, ribbon stack, or a round bundle. The fiber bundles or ribbons (i.e., collections of multiple fibers) can also be arranged in the shape of the light source in order to increase coupling efficiency. A typical bundle/ ribbon structure can include, for example, 2-36 light diffusing fibers **12**, or may include up to several hundred fibers **12**. Cable designs which are assemblies of multiple fibers are well known and could include ribbons, collections of multiple ribbons, or fibers gathered into a tube. Such fibers may include one or more light diffusing fibers **12**.

Single fibers

[0083] A bright continuous light source coupled into a light diffusing fiber can be utilized for different application such as signs, or display illumination. If the illumination system utilizes a single fiber **12** with core diameter of 125-300 μm, a multimode laser diode could be used as

a light source for providing light into the fiber **12**. An exemplary lighting fixture (bright perimeter illuminator for the display screen) using a single fiber **12** with a reflective coating directing light in one direction is shown in **FIG. 8A**. According to some embodiments, single or multiple fiber illumination with the light diffusing fiber(s) **12** can be utilized in aqueous environments, for example for lighting boat docks, fishing lines or lures, and related applications where the small flexible size of the light diffusing fiber **12** and the ability to be safely immersed in water are highly desirable. The light diffusing fiber **12** may also be useful for exit lighting, illuminating pathways, emitting IR radiation for room detectors, or used a thread in clothing, particularly protective/reflective clothing to further enhance visibility of the wearer. Examples of the use of the light diffusing fiber **12** in decorative illumination are manifold, but a few examples are use in appliance lighting and edge effects, automotive/aircraft illumination, or household and furniture illumination.

[0084] **FIG. 8B** illustrates an example embodiment of a biological growth system **98** and an illumination system **100** as used in the biological growth system, wherein biological chamber **170** is in the form of a flask with an interior **172**. The light source **150** and optical coupling system **160** are configured to couple light from the light source into the input ends of light conducting fiber. The output end of the low-scatter light conducting fiber **12A** is coupled to the input end of the light diffusing fiber **12** (light source fiber). In the embodiment of **FIG. 8B**, the light-source fiber **12** is formed from a single counter-wound fiber. It is noted that the fiber **12** can wound around a support structure to form a light-source fiber portion where guided light is scattered from the fiber outer surface to form an extended light source that emits substantially uniform radiation. The bends in the light-source fiber portion are formed to enhance the amount of scattering in the light diffusing fiber **12**. Counter-winding at least one fiber can increase the uniformity of the radiation by compensating for the effects of decreasing emitted radiation along the length of the light-source fiber portion. Multiple fibers **12** can be wound in sequence around a support structure, with each fiber coupled to the light source, can be used to form a lengthy extended source. The light diffusing fiber **12** can be configured to suit a variety of biological chamber geometries and provides light to the biological material growth of biological material **180**. The biological material **180** may be, for example, algae (e.g., algae colonies, algae blooms) or bacteria (e.g., cyanobacteria). In an example embodiment, biological material **180** may be suspended in a support medium **184** such as water.

Coatings

[0085] In an example embodiment, fiber **12** may include a coating **44** as discussed above in connection with **FIG. 2**. In one exemplary embodiment, coating **44** includes a hydrophilic coating layer such as a UV-cured acrylate coating that provides improved wet adhesion. The coating layer may be UV curable coatings comprising a low modulus primary coating layer (typically <3 MPa) adjacent to the glass and a higher modulus secondary coating layer (typically > 50 MPa). The higher modulus secondary coating layer is adjacent to, and situated over the primary (lower modulus) coating layer. Other, or additional coatings, applied either as a single layer coating or as a layer in a multi-layer coating may also be utilized. Examples of such materials are hydrophilic coating **44A** (not shown) which serves as a cell growth medium or a coating containing a material to provide additional scattering to the escaped light. These coatings may also serve as a protective covering for the fiber **12**.

[0086] Exemplary hydrophilic coatings **44A** for use in coating **44** are those commonly used for improving cell adhesion and growth to surfaces and contain carboxylic acid functionality and amine functionality (e.g. formulations containing acrylic acid or acrylamides). In addition, hydrophilic coatings **44A** may be enhanced by serving as a reservoir for nutrients essential for the growth of biological material.

[0087] In some exemplary embodiments, coating **44** includes fluorescent or ultraviolet absorbing molecules that serve to modify radiated light. Suitable up or down converter molecules may also be included in the coating to produce light of differing wavelengths from that of the input light source. Ink coating layers may also be applied to alter the color or hue of the emitted light. Other coating embodiments include molecules capable of providing additional scattering to the light emitted from the fiber. A further embodiment may be the inclusion of photo-active catalysts onto the coating that may be used to increase the rate of photo-reactions. One example of just such a catalyst is rutile TiO₂, as a photo-catalyst.

[0088] According to some embodiments, light diffusing fibers **12** may be enclosed within a polymeric, metal, or glass covering (or coatings), wherein said the coating or covering has a minimum outer dimension (e.g., diameter) greater than 250 μm. If the fiber(s) has a metal coating, the metal coating may contain open sections, to allow light to be preferentially directed into a given area. These additional coatings or coverings may also contain additional compounds to vary the emitted light or catalyze reactions in the same manner as described above for the coatings coated on the fiber.

[0089] As stated above, the light diffusing fiber **12** may comprise a hydrophilic coating disposed on the outer surface of the optical fiber. Also, fluorescent species (e.g., ultraviolet-absorbing material) may be disposed in the optical fiber coating, as well as molecules capable of providing additional scattering of the emitted light. According to some embodiments the light source coupled to the light diffusing fiber **12** generates light in 200 nm to 500 nm wavelength range and the fluorescent material (fluorescent species) in the fiber coating generates either white, green, red, or NIR (near infrared) light.

[0090] Furthermore, an additional coating layer may be provided on the fiber outer surface. This layer may be configured to modify the radiated light, alter the interaction of the coating materials. Examples of just such a coating would be coatings containing materials such as, but not limited to, poly (2-acrylamido-2-methanesulfonic acid), ortho-nitrobenzyl groups, or azobenzene moieties respectively.

Exemplary illumination system configurations

[0091] Some exemplary embodiments of an illumination system include: (i) a light source that generates light having at least one wavelength λ within the 200 nm to 2000 nm range; and (ii) at least one light diffusing optical fiber **12**. The fiber **12** comprises having a core, cladding, and a plurality of nano-sized structures **32** situated within the core or at a core-cladding boundary. This optical fiber further includes an outer surface, and at least one end optically coupled to the light source. As described above, the light diffusing optical fiber **12** is configured to scatter guided light via the nano-sized structures such as voids away from the core and through the outer surface, to form a light-source fiber portion having a length that emits substantially uniform radiation over its length. The light diffusing optical fiber **12** has a scattering-induced attenuation greater than 50 dB/km for one or more wavelength(s) within the 200 nm to 2000 nm range (e.g. 400-700nm, or 1 μ m to 2 μ m). The fiber **12** may have a plurality of bends formed therein so as to preferentially scatter light via the nano-sized structures **32** away from the core **20** and through the outer surface within specified area(s). Preferably, the deviation of the illumination intensity of scattered light is less than 30% of the maximum scattering illumination intensity along the length. According to some embodiments the scattering-induced attenuation is between 100 dB/km and 6000 dB/km, or higher. In some embodiments, attenuation due to scattering of fiber **12** is 6000 dB/km to 20000 dB/km for the one or more wavelength(s) situated within 200 nm to 2000nm range. According to some embodiments fiber **12** has a length between 0.5 m and 100 m and the scattering-induced

attenuation is between 300 dB/km and 5000 dB/km for the one or more wavelength(s) situated within 200 nm to 2000nm range, and/or is greater than 3dB/length of fiber. In other embodiments, the fiber **12** has a length between 0.1 m and 0.5 m and the scattering-induced attenuation is between 5000 dB/km and 20,000 dB/km for the one or more wavelength(s) situated within 200 nm to 2000nm range. Preferably, the nano-sized structures **32** are gas filled voids (e.g., SO₂ filled voids) with diameter of greater than 10 nm, preferably greater than 50 nm, more preferably greater than 100 nm. Preferably the fiber cladding is either glass, or polymer, and is at least 20 μm thick. The cladding, in combination with said core, provides a NA of 0.2 or greater. As described above, uniformity of illumination along the fiber length (with about 30% from maximum intensity, and preferably within about 20% from maximum intensity, and more preferably within about 10% from maximum intensity) can be accomplished by controlling the fiber tension during the draw process. As previously discussed, the uniformity of the illumination can be further reduced by utilizing a reflector coupled to the end of the fiber that is opposite to the end of the fiber coupled to the optical source.

[0092] Thus, according to some embodiments, the light diffusing fiber **12** includes a core at least partially filled with nanostructures for scattering light, a cladding surrounding the core, and at least one coating surrounding the cladding. For example, the core and cladding may be surrounded by a primary and secondary coating layers, and/or by an ink layer. In some embodiments the ink layer contains pigments to provide additional absorption and modify the spectrum of the light scattered by the fiber (e.g., to provide additional color(s) to the diffused light). In other embodiments, one or more of the coating layers comprises molecules which convert the wavelength of the light propagating through the fiber core such that the light emanating from the fiber coating (light diffused by the fiber) is at a different wavelength. In some embodiments the ink layer and/or the coating layer may comprise phosphor in order to convert the scattered light from the core into light of differing wavelength(s). In some embodiments the phosphor and/or pigments are dispersed in the primary coating. In some embodiments the pigments are dispersed in the secondary coating, in some embodiments the pigments are dispersed in the primary and secondary coatings. In some embodiments the phosphor and/or pigments are dispersed in the polymeric cladding.

[0093] According to some embodiments the optical fiber **12** includes a primary coating, an optional secondary coating surrounding the primary coating and/or an ink layer (for example

located directly on the cladding, or on one of the coatings. The primary and/or the secondary coating may comprise at least one of: pigment, phosphors, fluorescent material, UV absorbing material, hydrophilic material, light modifying material, or a combination thereof.

[0094] The plurality of light diffusing fibers **12** can be bundled together in at least one of: a ribbon, ribbon stack, or a round bundle. The fiber bundles or ribbons (i.e., collections of multiple fibers) can also be arranged in the shape of the light source in order to increase coupling efficiency. A typical bundle/ ribbon structure can include, for example 2 to 36 light diffusing fibers **12**, or, with overstacking of fibers, may include up to several hundreds of fibers **12**.

[0095] As stated above, the optical fiber may comprise a hydrophilic coating disposed on the outer surface of the optical fiber. Alternatively, a hydrophilic coating may be disposed on the outer surface of the fiber ribbon. A ribbon may also be arranged in the shape of the light source, to provide better coupling between the light diffusing fibers **12** and the light source. An advantage derived from the ribbon structure is that winding of the individual fibers may not be necessary, because the ribbons may form bent structures such as waves, helices, or spirals thereby allowing light to scatter into desired areas. Furthermore, the use of multi-fiber ribbons affords the possibility of having large stacks of ribbons. Such ribbon stacks would provide a more concentrated amount of light, and also open the possibility to the use of different light sources, such as red lasers, sunlight, light emitting diodes, or guidance of point light sources. For example, according to one embodiment, a plurality of light diffusing optical fibers **12** may be optically coupled to either a single light source or a plurality of light sources, while the light diffusing optical fibers **12** are bundled together in at least one of: a ribbon, ribbon stack, or a round bundle. Furthermore the bundles or ribbons of light diffusing fibers **12** may be connected to a light source(s) by a transmission fiber capable of directing the light towards the light diffusing fiber with a minimum of loss. This latter configuration can be expected to be very useful for remote lighting applications where light is gathered from a source distant from the area where light is to be delivered.

[0096] It is to be understood that the foregoing description is exemplary of the invention only and is intended to provide an overview for the understanding of the nature and character of the invention as it is defined by the claims. The accompanying drawings are included to provide a further understanding of the invention and are incorporated and constitute part of this specification. The drawings illustrate various features and embodiments of the invention

which, together with their description, serve to explain the principals and operation of the invention. It will become apparent to those skilled in the art that various modifications to the preferred embodiment of the invention as described herein can be made without departing from the spirit or scope of the invention as defined by the appended claims.

What is claimed is:

1. An illumination system, comprising:

a light source that generates light having at least one wavelength between 200 nm and 2000 nm; and

at least one light diffusing optical fiber having a core, primary cladding, and a plurality of nano-sized structures situated within said core or at a core-cladding boundary, said optical fiber further including an outer surface, and an end optically coupled to the light source,

wherein the fiber is configured to scatter guided light via said nano-sized structures away from the core and through the outer surface, to form a light-source fiber portion having a length that emits substantially uniform radiation over its length, said fiber having a scattering-induced attenuation greater than 50 dB/km for said wavelength.

2. The illumination system of claim 1, wherein said fiber has a plurality of bends formed therein to preferentially scatter guided light via said nano-sized structures away from the core and through the outer surface.

3. The illumination system of claim 1, wherein said fiber radiation is substantially uniform, such that the difference between the minimum and maximum scattering illumination intensity is less than 30% of the maximum scattering illumination intensity.

4. The illumination system of claim 1, wherein said fiber having scattering-induced attenuation is 100 to 6000 dB/km for said wavelength.

5. The illumination system of claim 4, wherein said fiber has a length of 0.5 m to 100 m and said fiber scattering-induced attenuation is 300 dB/km to 6000 dB/km for said wavelength.

6. The illumination system of claim 4, wherein said fiber has a length, L , between 0.5 m and 100 m and said fiber attenuation is greater than $3\text{dB}/L$.

7. The illumination system of claim 1, wherein attenuation of the fiber due to scatter is 6000 dB/km to 20000 dB/km for said wavelength.

8. The illumination system of claim 1, comprising a plurality of light diffusing optical fibers, each having a core, cladding, and a plurality of nano-sized structures situated within said core

or at a core-cladding boundary, each of said optical fibers further including an outer surface, and an end optically coupled to the light source,

wherein each of said light diffusing fibers configured to scatter guided light via said nano-sized structures away from the core and through the outer surface, to form a light-source fiber portion having a length that emits substantially uniform radiation over its length, each of said light diffusing fibers having a scattering-induced attenuation greater than 50 dB/km for said wavelength.

9. The illumination system of claim 1 wherein said fiber is a multimode fiber, said fiber core has a diameter greater than 50 μm and less than 500 μm .

10. The illumination system of claim 1 wherein said light diffusing fiber is a multimode fiber, said fiber core having an $\text{NA} > 0.2$.

11. The illumination system of claim 1 wherein the core of said light diffusing fiber comprises silica.

12. The illumination system of claim 1, wherein said nano-sized structures are situated in the core.

13. The illumination system of claim 12, wherein said core has an outer diameter R_c , said core includes: (i) a solid inner core section with an outer diameter R_1 , such that $0.05R_c > R_1 > 0.9R_c$; (ii) nano-structured region having a width W_2 wherein $0.05R_c > W_2 > 0.9R_c$; and (iii) outer solid core region having a width between $0.1R_c > W_s > 0.9R_c$, wherein each section of said core comprised silica glass.

14. The illumination system of claim 13, wherein said core comprises silica doped with at least one of the following dopants: Ge, F.

15. The illumination system of claim 12, wherein the entire core comprises nano-sized structures.

16. The illumination system of claim 1, wherein said cladding comprises either silica based glass or polymer, said cladding being at least 20 μm thick.

17. The illumination system of claim 1, wherein said fiber further includes at least one coating surrounding said cladding.
18. The illumination system of claim 1, wherein said plurality of nano-sized structures is situated at a core-cladding boundary and the nano-structured region including said nano-sized structures has a width of at least 7 μm ; and wherein said cladding diameter is at least 125 μm .
19. The illumination system of claim 1, wherein said nano-sized structures are gas filled voids with diameter of greater than 10 nm.
20. A method of making a light diffusing fiber to control uniformity of illumination along the fiber length wherein the minimum scattering illumination intensity is not less than 0.7 the maximum scattering illumination intensity, by controlling fiber tension during draw process.
21. The illumination system of claim 3, wherein: (i) each light diffusing optical fiber is optically coupled to either the light source or a plurality of light sources, (ii) the plurality of light diffusing optical fibers is bundled together in at least one of: a ribbon, ribbon stack, or a round bundle.
22. The illumination system of claim 1, further comprising fluorescent and/or scattering species disposed in the light diffusing optical fiber coating to provide substantially uniform scattering intensity.
23. The illumination system of claim 22, when said light source generates light in 200-500 nm wavelength range and fluorescent material in said coating generates either white, green, red, or NIR (near infrared) light.
24. The illumination system of any of the preceding claims wherein said fiber has a glass core at least partially filled with nanostructures for scattering light, said core being surrounded by a either polymer or glass cladding, and at last one coating layer surrounding said cladding.
25. The illumination system of claim 24 wherein the cladding is surrounded by a primary and an optional secondary coating, and/or an ink layer.

26. The illumination system of claim 24 or 25 wherein the ink layer comprises: pigments or phosphors, fluorescent material, UV absorbing material, hydrophilic material, light modifying material, or a combination thereof.
27. The illumination system of claim 25 wherein: the cladding, and/or primary coating, and/or the secondary coating comprises at least one of: pigment, phosphors, fluorescent material, UV absorbing material, hydrophilic material, light modifying material, or a combination thereof.
28. A light diffusing optical fiber comprising:
- a core, a cladding, and a plurality of nano-sized structures situated within said core or at a core-cladding boundary, said optical fiber further including an outer surface and is configured to (i) scatter guided light via said nano-sized structures away from the core and through the outer surface, (ii) have a scattering-induced attenuation greater than 50 dB/km at illumination wavelength; and
 - said fiber including at least one coating such that either said cladding or said at least one coating includes phosphor or pigments.
29. The light diffusing fiber of claim 28 wherein the entire core includes nano-sized structures.
30. A light diffusing optical fiber comprising:
- a core, and a plurality of nano-sized structures situated within said core such that the entire core includes nano-structures, said optical fiber further including an outer surface and is configured to (i) scatter guided light via said nano-sized structures away from the core and through the outer surface, (ii) have a scattering-induced attenuation greater than 50 dB/km at illumination wavelength.
31. A light diffusing optical of claim 30, wherein said fiber includes a cladding.
32. A light diffusing optical of claim 30, wherein said fiber includes a coating.
33. A light diffusing optical of claim 30, wherein said fiber does not include cladding.

FIG. 1

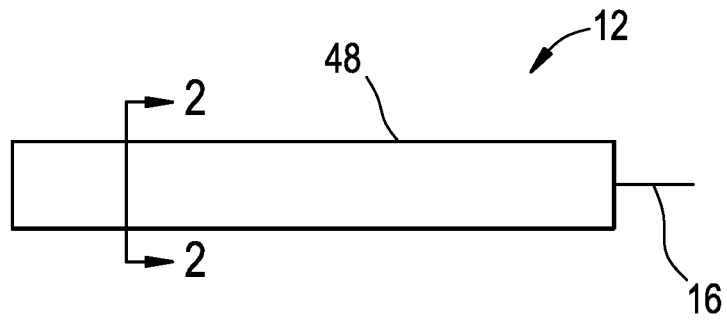

FIG. 2

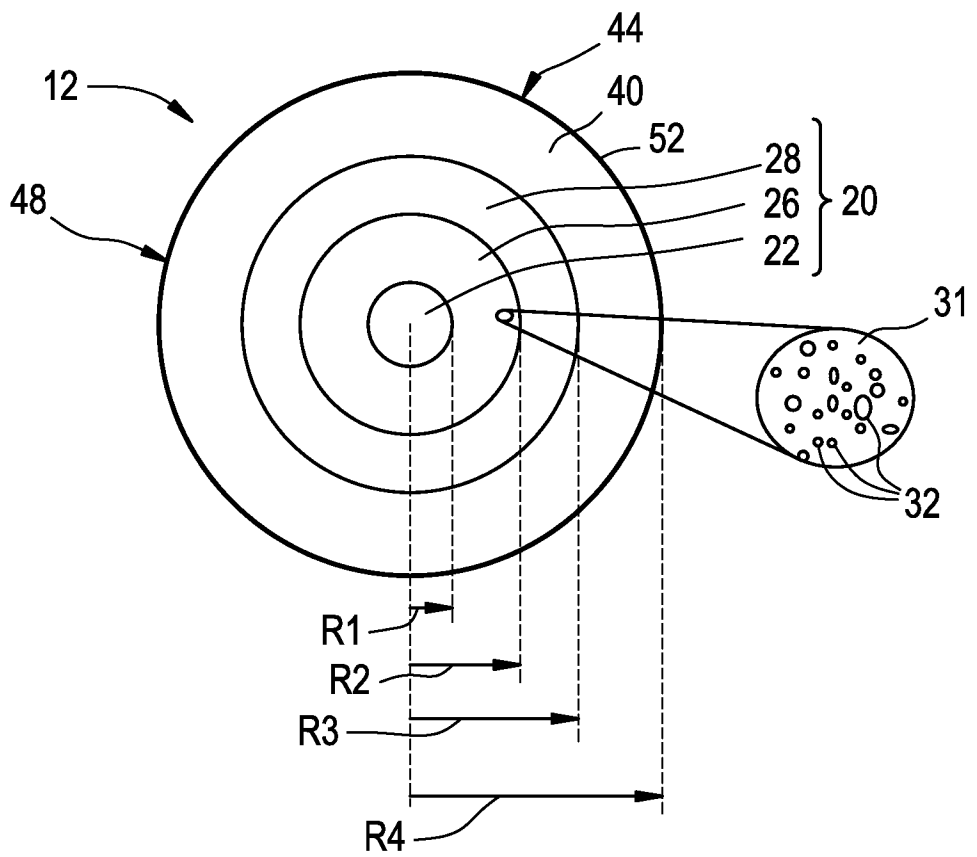

FIG. 3A

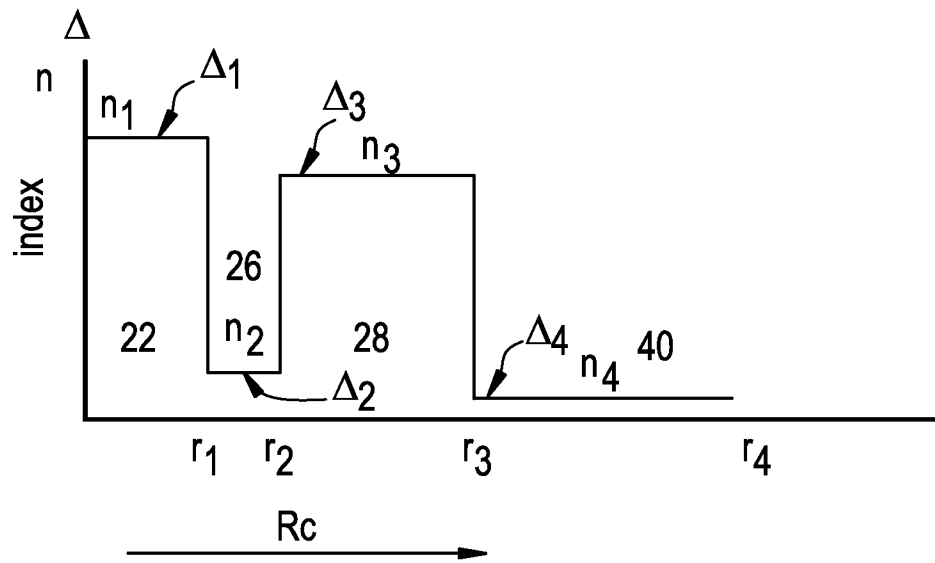

FIG. 3B

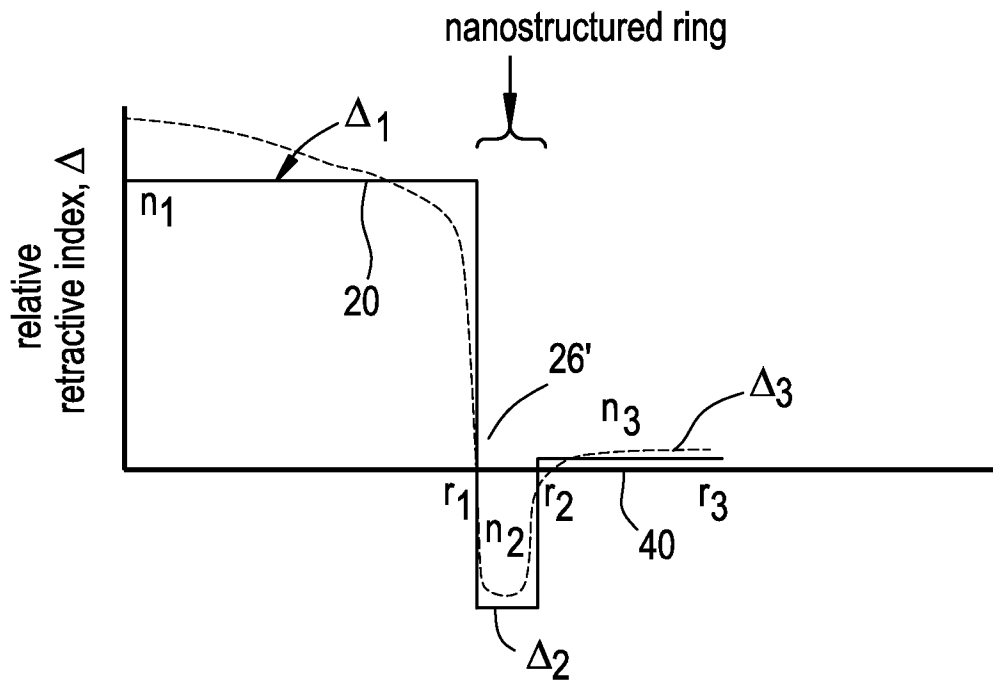

FIG. 3C

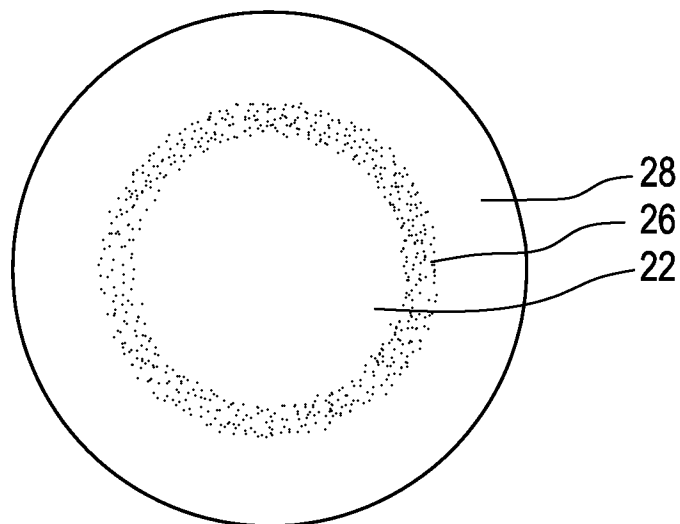

FIG. 4A

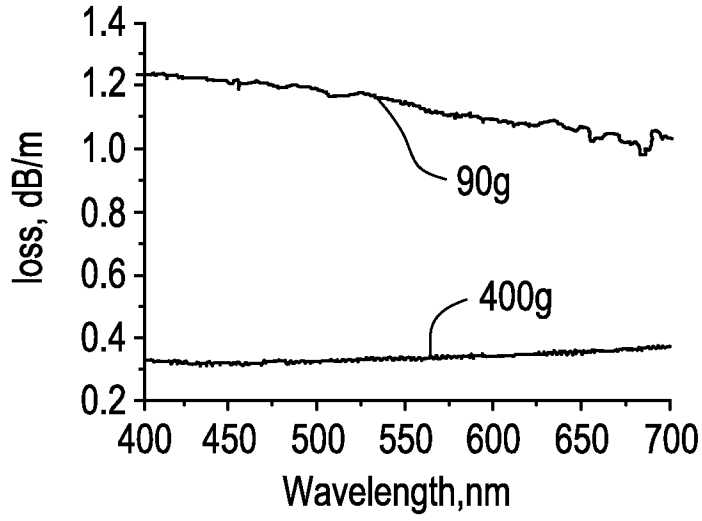

FIG. 4B

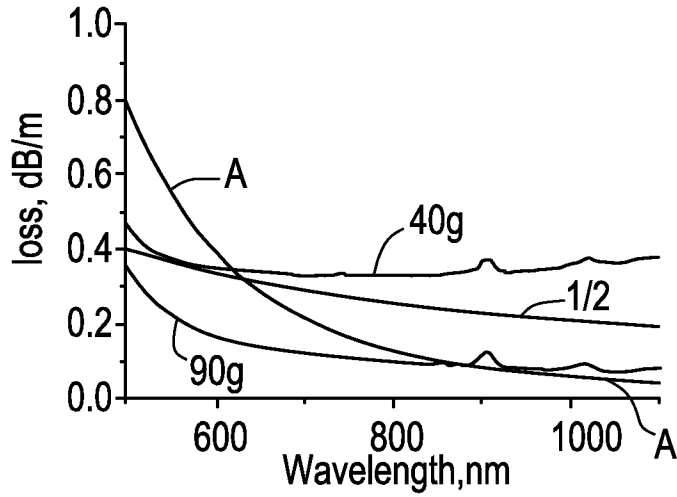

FIG. 5

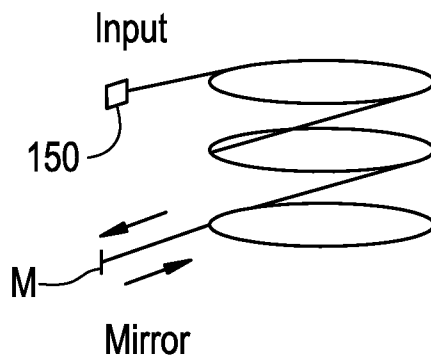

FIG. 6A

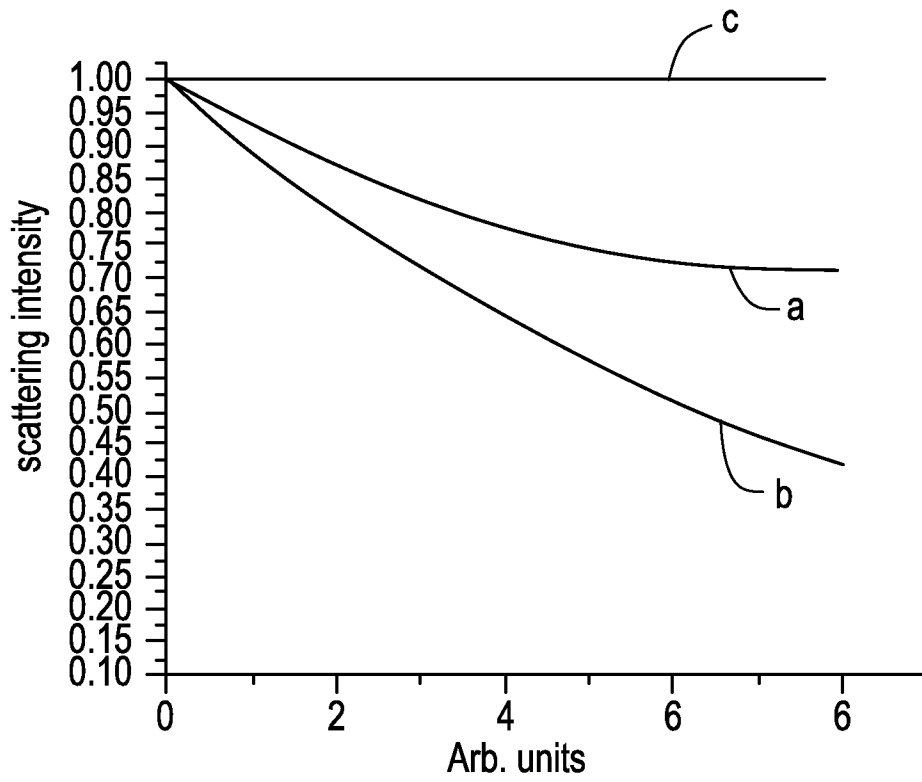

FIG. 6B

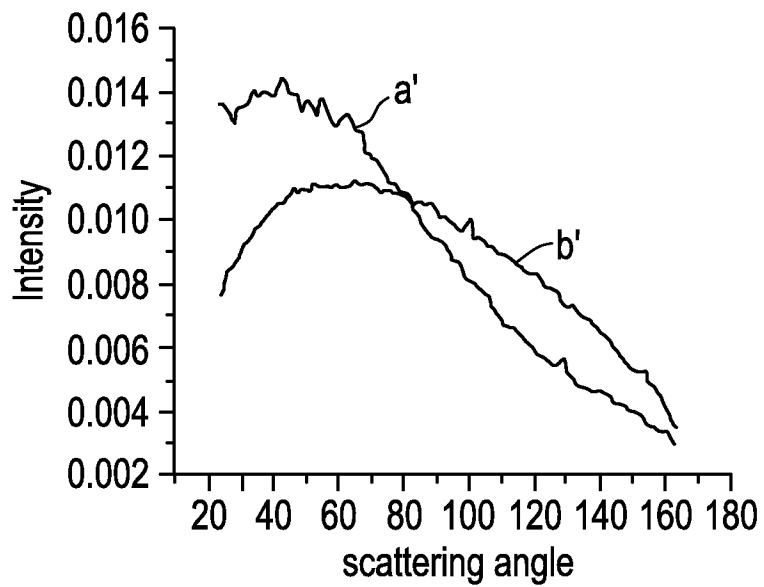

FIG. 7

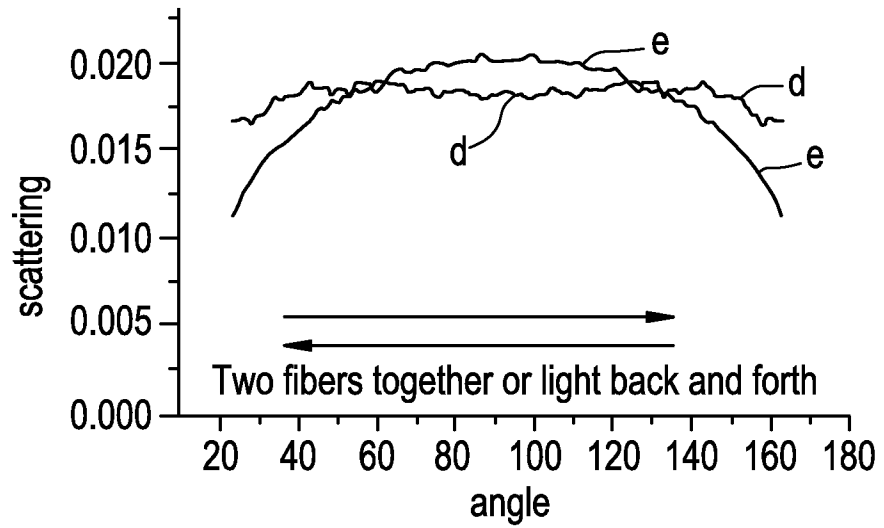

FIG. 8A

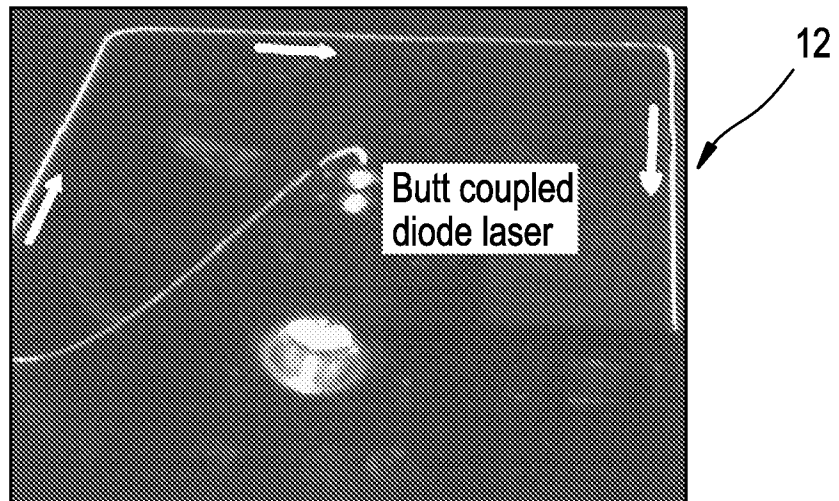
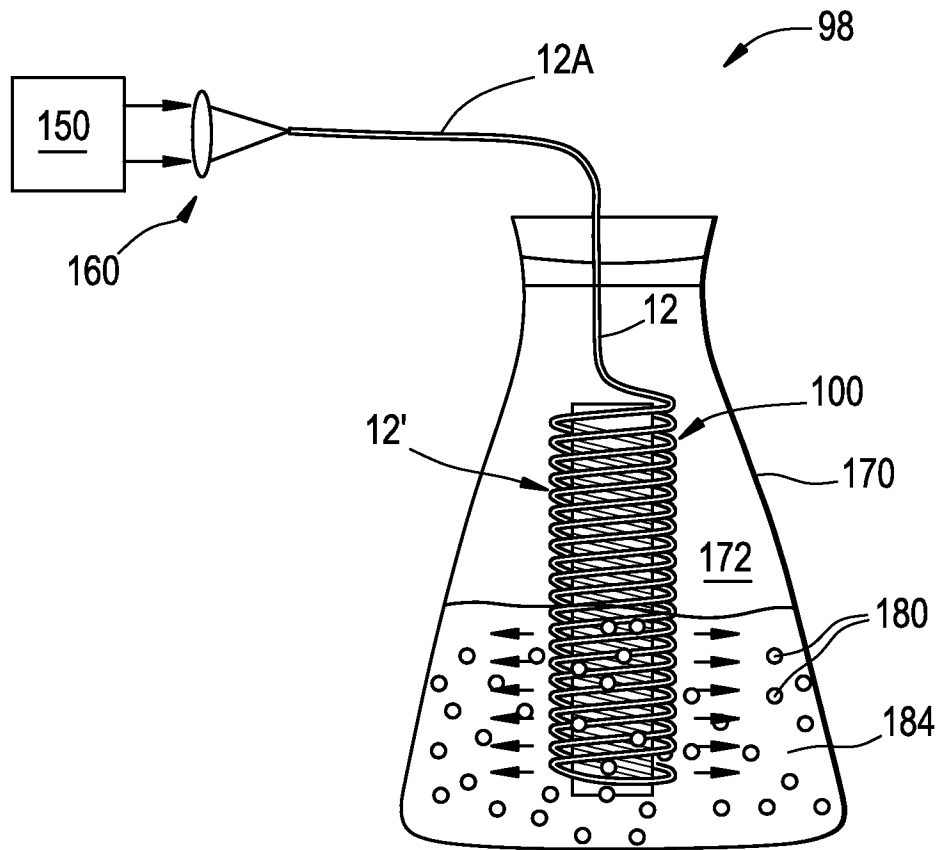

FIG. 8B



INTERNATIONAL SEARCH REPORT

International application No
PCT/US2010/057395

A. CLASSIFICATION OF SUBJECT MATTER
 INV. G02B6/00 G02B6/02 F21V8/00
 ADD.

According to International Patent Classification (IPC) or to both national classification and IPC

B. FIELDS SEARCHED

Minimum documentation searched (classification system followed by classification symbols)
 G02B F21V

Documentation searched other than minimum documentation to the extent that such documents are included in the fields searched

Electronic data base consulted during the international search (name of data base and, where practical, search terms used)
 EPO-Internal, WPI Data

C. DOCUMENTS CONSIDERED TO BE RELEVANT		
Category*	Citation of document, with indication, where appropriate, of the relevant passages	Relevant to claim No.
X	WO 02/095289 A1 (POLY OPTICS AUSTRALIA PTY LTD [AU]; FRANKLIN JAMES BRUCE [AU]; SMITH G) 28 November 2002 (2002-11-28)	1-10,12, 15-18, 21-23, 28-32
A	* abstract; figure 1 page 8, lines 3-10; claim 13 page 10, lines 11-15	20
X	US 6 169 836 B1 (SUGIYAMA HIDEO [JP] ET AL) 2 January 2001 (2001-01-02)	1-10,12, 15-18, 21-23, 28-32
A	column 1, lines 9-35; figures 1-2 column 2, lines 55-63 column 4, lines 11-20 column 5, lines 58-61	20
	----- -/--	

Further documents are listed in the continuation of Box C.

See patent family annex.

* Special categories of cited documents :

<p>"A" document defining the general state of the art which is not considered to be of particular relevance</p> <p>"E" earlier document but published on or after the international filing date</p> <p>"L" document which may throw doubts on priority claim(s) or which is cited to establish the publication date of another citation or other special reason (as specified)</p> <p>"O" document referring to an oral disclosure, use, exhibition or other means</p> <p>"P" document published prior to the international filing date but later than the priority date claimed</p>	<p>"T" later document published after the international filing date or priority date and not in conflict with the application but cited to understand the principle or theory underlying the invention</p> <p>"X" document of particular relevance; the claimed invention cannot be considered novel or cannot be considered to involve an inventive step when the document is taken alone</p> <p>"Y" document of particular relevance; the claimed invention cannot be considered to involve an inventive step when the document is combined with one or more other such documents, such combination being obvious to a person skilled in the art.</p> <p>"&" document member of the same patent family</p>
--	--

Date of the actual completion of the international search 22 March 2011	Date of mailing of the international search report 31/03/2011
Name and mailing address of the ISA/ European Patent Office, P.B. 5818 Patentlaan 2 NL - 2280 HV Rijswijk Tel. (+31-70) 340-2040, Fax: (+31-70) 340-3016	Authorized officer Riblet, Philippe

INTERNATIONAL SEARCH REPORT

International application No.
PCT/US2010/057395

Box No. II Observations where certain claims were found unsearchable (Continuation of item 2 of first sheet)

This international search report has not been established in respect of certain claims under Article 17(2)(a) for the following reasons:

1. Claims Nos.:
because they relate to subject matter not required to be searched by this Authority, namely:

2. Claims Nos.:
because they relate to parts of the international application that do not comply with the prescribed requirements to such an extent that no meaningful international search can be carried out, specifically:

3. Claims Nos.:
because they are dependent claims and are not drafted in accordance with the second and third sentences of Rule 6.4(a).

Box No. III Observations where unity of invention is lacking (Continuation of item 3 of first sheet)

This International Searching Authority found multiple inventions in this international application, as follows:

see additional sheet

1. As all required additional search fees were timely paid by the applicant, this international search report covers all searchable claims.

2. As all searchable claims could be searched without effort justifying an additional fees, this Authority did not invite payment of additional fees.

3. As only some of the required additional search fees were timely paid by the applicant, this international search report covers only those claims for which fees were paid, specifically claims Nos.:

4. No required additional search fees were timely paid by the applicant. Consequently, this international search report is restricted to the invention first mentioned in the claims; it is covered by claims Nos.:

Remark on Protest

- The additional search fees were accompanied by the applicant's protest and, where applicable, the payment of a protest fee.
- The additional search fees were accompanied by the applicant's protest but the applicable protest fee was not paid within the time limit specified in the invitation.
- No protest accompanied the payment of additional search fees.

INTERNATIONAL SEARCH REPORT

International application No
PCT/US2010/057395

C(Continuation). DOCUMENTS CONSIDERED TO BE RELEVANT		
Category*	Citation of document, with indication, where appropriate, of the relevant passages	Relevant to claim No.
X A	US 2008/158905 A1 (CHUANG CHIA-CHENG [TW] ET AL) 3 July 2008 (2008-07-03) * abstract; figures 5-18 paragraphs [0008] - [0016], [0045] - [0046], [0051], [0060] -----	1-18, 21-33 20
X A	US 4 422 719 A (ORCUTT DONALD E [US]) 27 December 1983 (1983-12-27) * abstract; figures 1-6 column 5, lines 8-48 column 2, lines 3-4 -----	1-10,12, 15-19, 21-23, 28-32 20
A	JP 9 222517 A (SHIYUTOKEN MATSUSHITA TECHNICA) 26 August 1997 (1997-08-26) * abstract; figures -----	1-33
A	KR 2002 0066493 A (INST SCIENCE & TECH KWANGJU [KR]; SKC CO LTD [KR]) 19 August 2002 (2002-08-19) * abstract; figures -----	20
A	JP 2008 026814 A (SUMITOMO ELECTRIC INDUSTRIES) 7 February 2008 (2008-02-07) paragraphs [0019] - [0021], [0035]; figures -----	20
A	JP 6 118239 A (MITSUBISHI RAYON CO) 28 April 1994 (1994-04-28) * abstract -----	20
A	US 5 067 831 A (ROBBINS JOHN A [US] ET AL) 26 November 1991 (1991-11-26) * abstract; figures column 13, line 33 - column 14, line 32 -----	20

INTERNATIONAL SEARCH REPORT

Information on patent family members

International application No PCT/US2010/057395

Patent document cited in search report	Publication date	Patent family member(s)	Publication date
WO 02095289	A1	28-11-2002	CA 2486643 A1
			EP 1405008 A1
			JP 2004534966 T
			MX PA03010704 A
			NZ 530328 A
			US 2004196648 A1

US 6169836	B1	02-01-2001	JP 11326644 A

US 2008158905	A1	03-07-2008	NONE

US 4422719	A	27-12-1983	NONE

JP 9222517	A	26-08-1997	NONE

KR 20020066493	A	19-08-2002	NONE

JP 2008026814	A	07-02-2008	NONE

JP 6118239	A	28-04-1994	NONE

US 5067831	A	26-11-1991	NONE

This International Searching Authority found multiple (groups of) inventions in this international application, as follows:

1. claims: 1-19, 21-33

relates to a light diffusing optical fibre having a core, clad and nano-sized structures situated within the core or at the core-clad interface so as to emit from the sides light uniformly along a length of the optical fibre.

The problem to be solved is to provide strong side illumination.

The solution is to design the fibre such that the scattering-induced attenuation is greater than 50 dB/km at the operating wavelength.

2. claim: 20

relates to a method of making a light diffusing fibre.

The problem to be solved is how to make the fibre such that it emits light from the sides uniformly along a length of the optical fibre.

The solution is to control the fibre tension during draw process so that the minimum scattering illumination intensity is not less than 0.7 the maximum scattering illumination intensity.
