

May 7, 1968

B. W. WHITEFORD

3,381,564

AUTOMATIC FEEDING POWER-OPERATED ENVELOPE OPENER

Filed Dec. 8, 1965

2 Sheets-Sheet 1

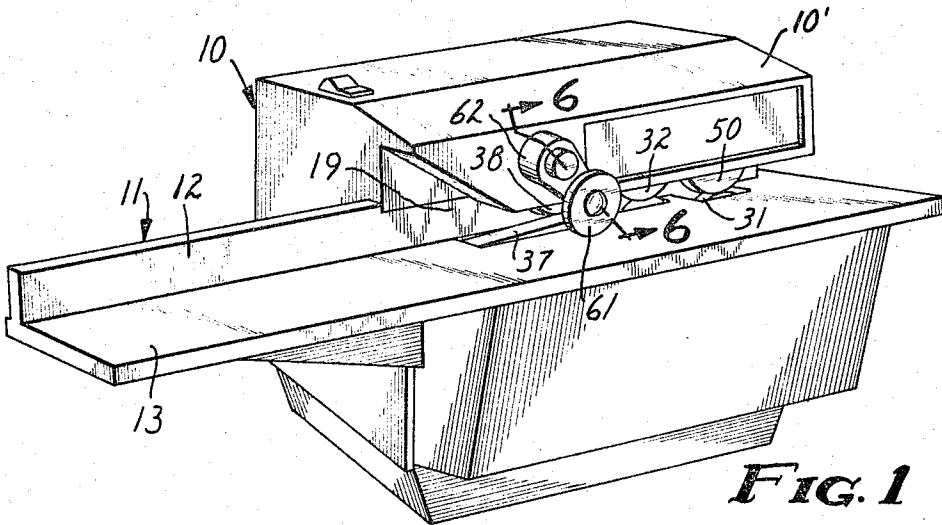

FIG. 1

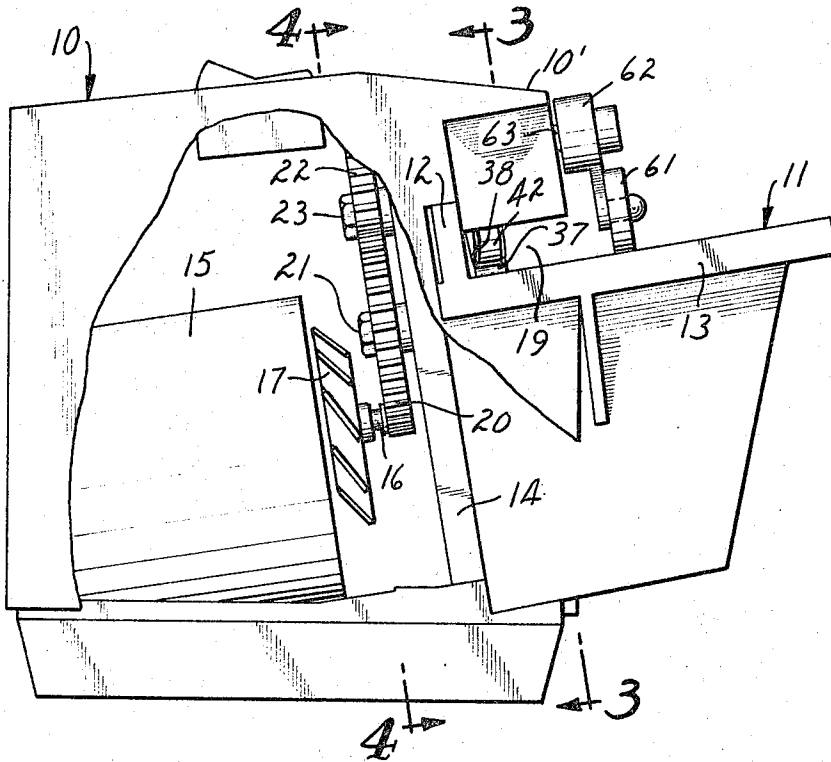

FIG. 2

INVENTOR
BRUCE W. WHITEFORD
BY *Merchant & Gould*
ATTORNEYS

May 7, 1968

B. W. WHITEFORD

3,381,564

AUTOMATIC FEEDING POWER-OPERATED ENVELOPE OPENER

Filed Dec. 8, 1965

2 Sheets-Sheet 2

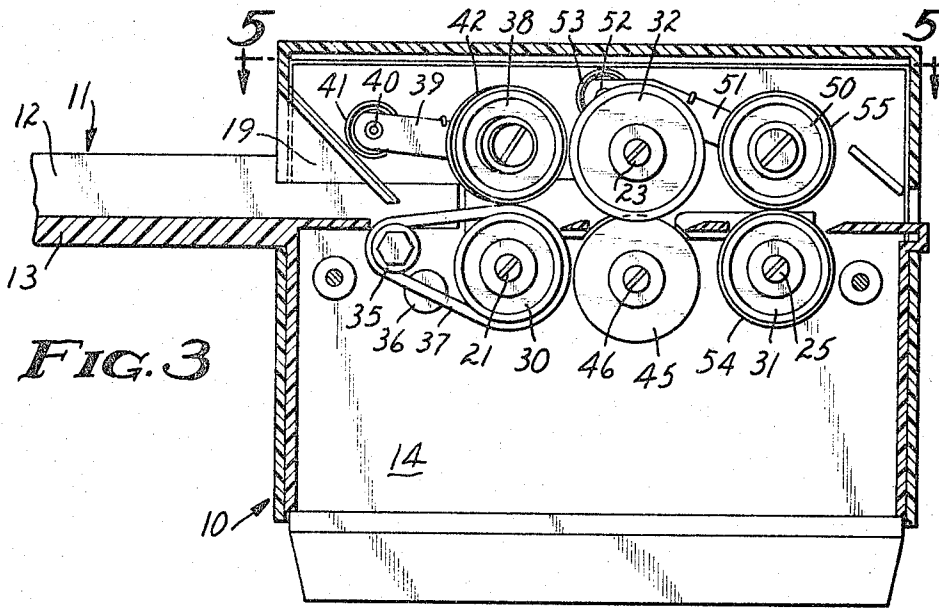

FIG. 3

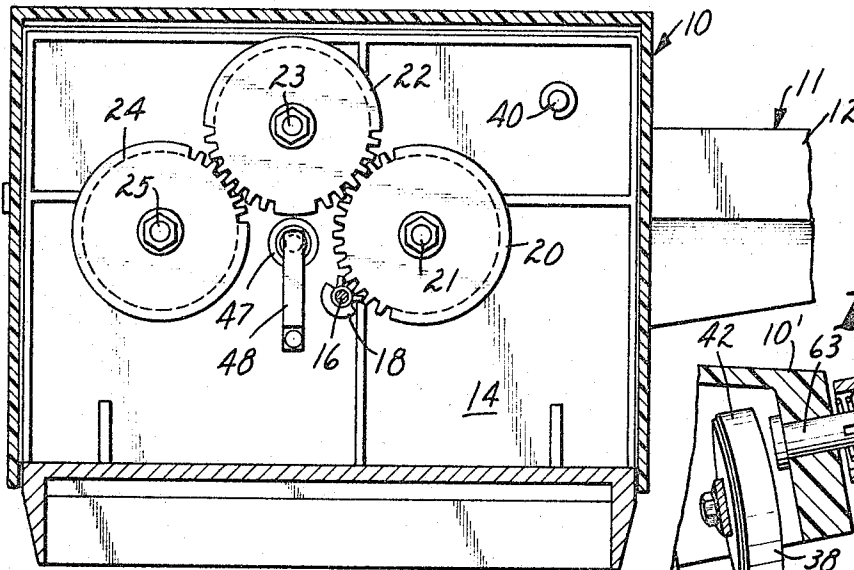

FIG. 4

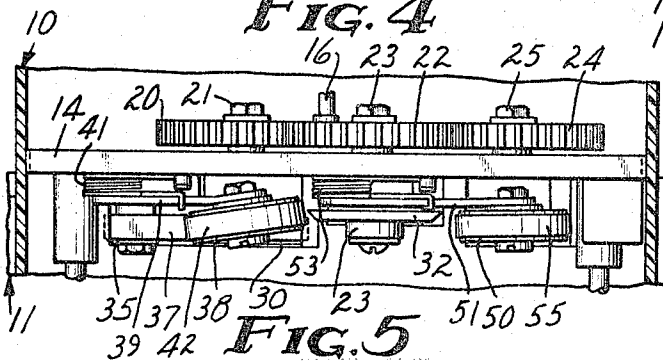

FIG. 5

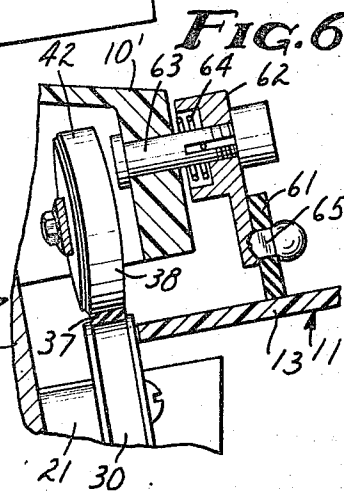

FIG. 6

INVENTOR
BRUCE W. WHITEFORD
BY *Merchant & Gould*
ATTORNEYS

1

2

3,381,564
AUTOMATIC FEEDING POWER-OPERATED
ENVELOPE OPENER

Bruce W. Whiteford, 8024 Northern Drive,
 Minneapolis, Minn. 55427

Filed Dec. 8, 1965, Ser. No. 512,489

3 Claims. (Cl. 83-417)

ABSTRACT OF THE DISCLOSURE

A housing having an envelope receiving horizontal surface and a vertical surface adjacent thereto. An endless belt positioned parallel to the vertical surface and adapted to remove envelopes from a stack and transport them along the horizontal surface. An idler wheel mounted above the belt and at an angle relative thereto such that the envelopes are urged into abutting engagement with the vertical surface. Rotating cutting blades spaced from the vertical surface for removing an edge from the envelopes. A pivotally mounted foot biased against the horizontal surface adjacent the belt to restrict the envelopes passing between the belt and the idler wheel to one at a time. An idler wheel and a driven wheel positioned opposite the cutting blades for removing the opened envelopes from the area of the cutting blades.

The present invention pertains to an automatic envelope opener and more particularly to an envelope opener which automatically removes and cuts an edge from the bottom envelope of a plurality or stack of envelopes placed thereon, after which the remaining envelopes are removed one at a time and opened.

In prior art envelope openers of the present type, individual envelopes must be placed manually in the device, which then removes an edge or otherwise opens the envelope, after which a second envelope may be manually placed in the device. These prior art devices are extremely slow and require the constant attention of an operator.

In the present envelope opener, a plurality of envelopes are stacked and placed on a tray of the device after which each succeeding bottom envelope is removed and opened automatically until the entire stack has been opened. Thus, the present device not only saves a great amount of time, since constant attention by the operator is not required, but also the amount of work by the operator is greatly reduced since individual handling of the envelopes is not required.

It is an object of the present invention to provide a new and improved automatic envelope opener.

It is a further object of the present invention to provide an automatic envelope opener into which a plurality of envelopes may be placed and which will open the envelopes one at a time, automatically.

These and other objects of this invention will become apparent to those skilled in the art upon consideration of the accompanying specification, claims, and drawings.

Referring to the drawings, wherein like characters indicate like parts throughout the figures;

FIG. 1 is a view in perspective of the automatic envelope opener;

FIG. 2 is an enlarged end view, parts thereof broken away;

FIG. 3 is a sectional view as seen from the line 3—3 in FIG. 2;

FIG. 4 is a sectional view as seen from the line 4—4 in FIG. 2;

FIG. 5 is a sectional view as seen from the line 5—5 in FIG. 3, parts thereof broken away; and

FIG. 6 is a sectional view as seen from the line 6—6 in FIG. 1.

In the figures the numeral 10 generally designates a housing having an envelope receiving tray 11 fixedly attached thereto along a front wall 14. The tray 11 has a somewhat L-shaped cross-section with the short arm 12 of the L extending upwardly and the long arm forming an envelope carrying surface 13 which slants upwardly and outwardly from the arm 11 at a slight angle with the horizontal. Thus, envelopes placed on the envelope carrying surface 13 have a tendency to slide inwardly until one edge butts against the upwardly extending arm 11. The tray 11 extends the length of the housing 10 and protrudes a substantial distance outwardly from one end thereof. The protruding portion of the tray 11 is adapted to initially receive a stock of envelopes thereon. A portion 10' of the housing 10 extends outwardly from the front wall 14 over the tray 11 to form an input 19 for the envelopes stacked on the tray 11.

A motor 15 having a shaft 16 and a cooling fan 17 rotatably attached thereto, is mounted within the housing 10 so that the shaft 16 extends toward the front wall 14 thereof and rotates about an axis substantially parallel to a plane containing the surface 13. A drive gear 18 is fixedly attached adjacent the outer end of the shaft 16 for rotation therewith. A first mating gear 20 is fixedly attached to a shaft 21 for rotation therewith. Shaft 21 is rotatably mounted in and extends through the front wall 14 of the housing 10 so that the gear 20 meshes with the gear 18 and the shaft 21 turns with the motor shaft 16 but at a substantially slower speed. A second gear 22, which is approximately the same size as gear 20 is fixedly mounted on a shaft 23. Shaft 23 is mounted in and extends through the front wall 14 of the housing 10 for rotation about an axis parallel with the axis of the shafts 21 and 16 and so that the gear 22 meshes with the gear 20 for rotation therewith. A third gear 24, which is substantially the same size as gears 22 and 20, is fixedly mounted on a shaft 25. Shaft 25 is mounted in and extends through the front wall 14 of the housing 10 for rotation about an axis parallel with the axes of the shafts 23, 21 and 16 so that the gear 24 meshes with the gear 22.

The shafts 21 and 25 each have a roller 30 and 31, respectively, fixedly attached to the outer end thereof. The rollers 30 and 31 and their associated shafts 21 and 25 are positioned below the attached tray 11 so that a small portion of each extends upwardly through a pair of openings in the surface 13. The shaft 23 has a rotary cutting wheel 32 fixedly attached to the outer end thereof which is positioned above the surface 13 so that the surface 13 is approximately tangent with the lower edge thereof. The rollers 30 and 31 and the cutting wheel 32 all lie in a plane which is perpendicular to the surface 13 and approximately parallel with but spaced from the outer surface of the front wall 14 and arm 12 of the tray 11.

A small pulley 35 is attached to the outer surface of the front wall 14 of the housing 10 for rotation about an axis parallel with the axis of the shaft 21 but spaced therefrom toward the input 19. The outer periphery of the roller 30 has a slight depression therein so that an endless belt 37 will be maintained in proper operating position thereon. The endless belt 37 is mounted for rotation about the pulley 35 and the roller 30 so that an upper relatively flat portion thereof lies slightly above the plane of the surface 13. A hub 36 is fixedly attached to the outer surface of the front wall 14 adjacent the belt 37 and between pulley 35 and roller 30 to prevent the belt 37 from running off the pulley 35 or roller 30 for reasons which will become apparent presently.

A roller 38, which is approximately the same size as the rollers 30 and 31, is rotatably mounted at one end of an arm 39. The other end of the arm 39 is rotatably mounted to the front wall 14 of the housing 10 by a shaft 40 which is positioned so that the center of the roller 38 lies approximately vertically above the center of the roller 30. However, the arm 39 has a bend therein so that the axis roller 38 is at an angle to the axis of roller 30. The roller 38 has a coating 42 of material, such as rubber or the like, which frictionally engages the upper surface of envelopes placed in the apparatus. A torsion spring 41 is placed around the shaft 40 and engaged with the arm 39 to provide a torque thereon in a clockwise direction, as viewed in FIG. 3, which forces the roller 38 against belt 37 on the roller 30.

A rotary cutting wheel 45 is fixedly mounted on a shaft 46 which is mounted for rotational and limited longitudinal movement within a bearing 47 fixedly mounted in the front wall 14 of the housing 10. The shaft 46 is positioned vertically below the shaft 23 with a small portion of the edge of the cutting wheel 45 overlapping a portion of the edge of the cutting wheel 32. A leaf spring 48 fixedly attached to the inner surface of the front wall 14 of the housing 10 provides a bias on the shaft 46 tending to force the cutting wheel 45 outwardly from the front wall 14 and maintaining a portion of the outer surface of the cutting wheel 45 in contact with a portion of the inner surface of the cutting wheel 32. The cutting wheel 45 extends through an opening in the surface 13 so that the overlapping portions of the cutting wheels 32 and 45 are substantially at the surface 13 and spaced slightly from the front wall 14 of the housing 10.

A roller 50, which is substantially the same diameter as the rollers 30, 31 and 38, is rotatably mounted on one end of an arm 51. The other end of the arm 51 is attached to a shaft 52 which is rotatably mounted in the front wall 14 of the housing 10. A torsion spring 53 mounted around the shaft 52 and connected to the arm 51 provides a torque on the arm 51 in a clockwise direction, referring to FIG. 3, so that the roller 50 bears against the roller 31. Both of the rollers 31 and 50 have an outer frictional material 54 and 55 respectively, which may be rubber or the like, for gripping the upper and lower surfaces of envelopes as they pass through the apparatus. All of the rollers 30, 31 and 50 and the cutting wheels 32 and 45 lie in approximately the same plane, with the roller 38 lying at a slight angle to that plane. The angle of the roller 38 has a tendency to force an envelope against the front wall 14 of the housing 10, or the arm 12, so that the cutting wheels 32 and 45 remove a substantially even amount of the edge of the envelope.

To prevent injury to an operator the portion 10' of the housing 10 overhangs approximately one-half of the tray 12 and encloses the rollers 38 and 50 and the cutting wheel 32 mounted above the tray 12, except for the input 19 and a longitudinal slot for sliding envelopes there-through. A rubber foot 61, which in this embodiment is a round disk, is fixedly attached to an arm 62 by a shaft 65. Arm 62 is in turn rotatably attached to the outer surface of the overhanging portion 10' of the housing 10 by a shaft 63. A torsion spring 64 biases the arm 62 in a clockwise direction, referring to FIG. 1, so that the foot 61 bears against the upper surface 13 of the tray 12. The foot 61 is positioned so that it lies in a plane parallel with the plane through the rollers 30, 31 and 50 but spaced outwardly from the housing 10 a short distance. The foot 61 drags or slides across envelopes being inserted into the input 19 and prevents more than one envelope from entering the input 19. Shaft 65 is constructed with a plurality of sides, rather than round, so that the foot 61 may be manually rotated as the bottom surface wears to insure a good contact with the envelopes.

Thus, a stack of envelopes is placed on the protruding portion of the tray 12 and the lower envelopes are gently started into the input 19. The endless belt 37

frictionally engages the lower surface of the bottom envelope and pulls it into the rotating knives 32 and 45. The foot 61 prevents the next succeeding envelope from passing between the rotating knives 32 and 45 until the first envelope has emerged from the other side. The rollers 31 and 50 engage the envelope as it passes through the rotating knives 32 and 45 and forces the open envelope out the far side of the housing 10. Each time the bottom envelope is pulled through the apparatus and opened the next succeeding envelope is gripped by the endless belt 37 and forced into the apparatus. This process continues until the entire stack of envelopes has been opened. The rotating knives 32 and 45 are positioned a short distance from the front wall 14 of the housing 10 so that only the extreme edge of the envelope is removed and, thus, the material therein is unharmed.

While I have shown and described a specific embodiment of this invention, further modifications and improvements will occur to those skilled in the art. I desire it to be understood, therefore, that this invention is not limited to the particular form shown and I intend in the appended claims to cover all modifications which do not depart from the spirit and scope of this invention.

What is claimed is:

1. An automatic envelope opener comprising:

- (a) a housing having a first surface adapted to receive a plurality of envelopes thereon in substantially vertical overlying relationship and a generally vertical surface adjacent thereto adapted to receive one edge of the envelope in abutting engagement therewith;
- (b) power means mounted within said housing and adapted to be connected to a suitable source of energy;
- (c) cutting means operatively attached to said power means and mounted on said housing in spaced relationship to said vertical surface for removing an edge of an envelope whereby said envelope is opened and material therein is removable;
- (d) an endless belt operatively attached to said power means for removing envelopes from said plurality of envelopes and supplying the envelopes to said cutting means, said belt being mounted on said housing generally parallel with said vertical surface;
- (e) an idler wheel mounted on said housing in engagement with said belt for rotation therewith about an axis angularly disposed with respect to said surface and said belt such that envelopes passing between said belt and said idler wheel are urged into abutting engagement with said surface; and
- (f) a second idler wheel and a driven wheel operatively attached to said power means and mounted on said housing in operative engagement adjacent said cutting means and opposite said belt for receiving cut envelopes and removing the cut envelopes from the area of said cutting means.

2. An automatic envelope opener as set forth in claim 1 having in addition a pivotally mounted foot means attached to said housing adjacent said belt and biased in a direction to butt against the upper surface of envelopes engaged by said belt and limit the number of envelopes passing between said belt and said idler wheel to one.

3. An automatic envelope opener as set forth in claim 2 wherein the bias on said pivotally mounted foot is variable to compensate for different thicknesses of envelopes.

References Cited

UNITED STATES PATENTS

2,106,191	1/1938	Ryan	83—417	X
2,157,232	5/1939	Dummer et al.	83—912	X
2,168,394	8/1939	Coleman et al.	83—417	
2,393,845	1/1946	Wagner et al.	83—424	X
3,301,116	1/1967	Owen	83—417	X