

(19) World Intellectual Property Organization
International Bureau



(43) International Publication Date
2 July 2009 (02.07.2009)

PCT

(10) International Publication Number
WO 2009/079684 A1

(51) International Patent Classification:
E21D 20/00 (2006.01) *E21D 21/00* (2006.01)
E21D 20/02 (2006.01)

(74) Agent: F B RICE & CO.; Level 23, 44 Market Street,
Sydney, New South Wales 2000 (AU).

(21) International Application Number:
PCT/AU2008/001838

(81) Designated States (unless otherwise indicated, for every kind of national protection available): AE, AG, AL, AM, AO, AT, AU, AZ, BA, BB, BG, BH, BR, BW, BY, BZ, CA, CH, CN, CO, CR, CU, CZ, DE, DK, DM, DO, DZ, EC, EE, EG, ES, FI, GB, GD, GE, GH, GM, GT, HN, HR, HU, ID, IL, IN, IS, JP, KE, KG, KM, KN, KP, KR, KZ, LA, LC, LK, LR, LS, LT, LU, LY, MA, MD, ME, MG, MK, MN, MW, MX, MY, MZ, NA, NG, NI, NO, NZ, OM, PG, PH, PL, PT, RO, RS, RU, SC, SD, SE, SG, SK, SL, SM, ST, SV, SY, TJ, TM, TN, TR, TT, TZ, UA, UG, US, UZ, VC, VN, ZA, ZM, ZW.

(22) International Filing Date:
15 December 2008 (15.12.2008)

(25) Filing Language: English

(26) Publication Language: English

(30) Priority Data:
2007907063 21 December 2007 (21.12.2007) AU

(84) Designated States (unless otherwise indicated, for every kind of regional protection available): ARIPO (BW, GH, GM, KE, LS, MW, MZ, NA, SD, SL, SZ, TZ, UG, ZM, ZW), Eurasian (AM, AZ, BY, KG, KZ, MD, RU, TJ, TM), European (AT, BE, BG, CH, CY, CZ, DE, DK, EE, ES, FI, FR, GB, GR, HR, HU, IE, IS, IT, LT, LU, LV, MC, MT, NL, NO, PL, PT, RO, SE, SI, SK, TR), OAPI (BF, BJ, CF, CG, CI, CM, GA, GN, GQ, GW, ML, MR, NE, SN, TD, TG).

(71) Applicant (for all designated States except US):
ALMINCO PTY LTD [AU/AU]; ACN 001 546 130,
503-505 Princes Highway, Fairy Meadow, NSW 2519
(AU).

(72) Inventor; and

(75) Inventor/Applicant (for US only): RICARDO, Di Pietro
[AU/AU]; 16-18 Hawthorn Street, Tarrawanna, NSW 2518
(AU).

Published:
— with international search report

(54) Title: SELF DRILLING ROCK BOLTING

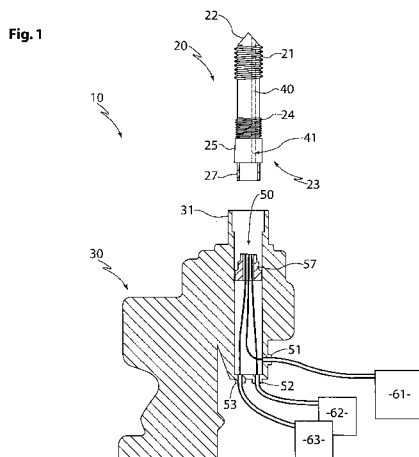

(57) Abstract: The present invention relates to self drilling rock bolting. In particular, the invention concerns both a drilling apparatus for rock bolting, and a rock bolt for use with the drilling apparatus. The drilling apparatus comprises within it a fluid injector having an upper part that mates with a self-drilling rock bolt for boring a hole. The injector includes three fluid inlets, three fluid outlets in the upper part, and three fluid conduits extending from respective inlets to respective outlets. The self drilling rock bolt comprises an elongate body having a leading end with a cutting tip, and around the tip a thread with a coarse pitch. The bolt also has a trailing end with an integral collar for fluid connection to a channel that extends axially through the body of the rock bolt to the leading end. Above the collar is a thread with a fine pitch. In other aspects the invention concerns a system comprising the drilling apparatus in combination with a rock bolt and a method for rock bolting using the system. The invention has application, but not exclusively, to rock bolting to stabilise the roof and walls of underground coal mines.

WO 2009/079684 A1

Title**Self Drilling Rock Bolting****Field of the invention**

5

The present invention relates to self drilling rock bolting. In particular, the invention concerns both a drilling apparatus for rock bolting, and a rock bolt for use with the drilling apparatus. In other aspects the invention concerns a system comprising the drilling apparatus in combination with a rock bolt and a method for rock bolting using the system. The invention has application, but not exclusively, to rock bolting to stabilise the roof and walls of underground coal mines.

10

Background of the Invention

15

Self drilling rock bolts are known for providing a single drilling and securing function. This negates the need to drill a hole, withdraw the drill bit and subsequently insert a bolt into the hole.

20

An existing method of securing a rock bolt to a coal strata is to drill a hole in the coal strata using a drill mast with a drill bit attached thereto. After the hole has been bored and the drill bit retracted, the drill bit is removed from the drill chuck. A rock bolt is then inserted into a drive dolly which forms an adapter between the bolt and a chuck. A resin capsule is then inserted into the bored hole. The bolt is then loaded into the bore hole, and the bolt causes the resin capsule to rupture. The bolt is then rotated to promote mixing and dispersion of the resin. Once the resin has set, a nut on the end of the bolt is rotated and the nut comes into abutment with the collar of the hole. The interaction between the collar of the borehole and the nut places a tensile loading on the stem of the bolt. Accordingly, the strata adjacent to the bolt is compressively loaded, thereby locally stabilising the strata.

30

A disadvantage with the above described bolting method is that it is a multi stage, and is thus time consuming operation. The complicated nature of this bolting installation technique also requires significant manual handling, which results in slow bolt installation cycle times.

35

One known self drilling rock bolting system uses a hollow bar. A passage through the centre of the bar serves as a flow path for water to flush rock cuttings out of the bore hole. The passage is also used for the ingress of a cementitious grout for subsequently securing the bolt to the adjacent wall of the borehole. The cementitious grout is generally
5 supplied in a secondary process. Accordingly, this system also suffers from being time consuming.

A known single stage self drilling rock bolt system is manufactured by Hilti Corporation. This system utilises a hollow bar with a chemical resin capsule housed in the centre of the
10 bar. Water for flushing drill cuttings is also permitted to travel through the inside of the bar in a separate annulus leading to the drill tip. In this system, after the hole boring has been completed, water is injected into the cavity containing the resin capsule. The water ruptures the resin capsule, forcing resin through a hole in the tip of the bar to the bore hole. The resin then sets, bonding the bolt to the rock strata.

15

The equipment used in the Hilti system is based upon conventional drilling equipment, with the addition of the water injection function to disperse the resin. A disadvantage with this system is that the resin capsule may prematurely rupture during transportation, or during the boring process, prior to completion of the boring process. A further
20 disadvantage is that the bolts have a limited shelf life on account of the expiration of the resin capsule.

Other known self drilling rock bolt systems use a mechanical expansion shell, similar to a Dynabolt™. The expansion of the shell is affected by the tightening of a nut, against the
25 collar of a hole. The bored hole is then filled with cementitious grout to prevent corrosion, and to assist in the load transfer of the supported strata. A disadvantage this type of system is that the bolt is grouted in a secondary process, requiring the use of grouting equipment that is separate from the drilling equipment. This increases the installation cycle times and the labour required to install the bolts.

30

Summary of the Invention

In a first aspect the invention is a drilling apparatus for rock bolting with a self-drilling rock bolt, comprising within it a fluid injector having an upper part that mates with a self-

drilling rock bolt inserted into the drilling apparatus for boring a hole. The injector includes three fluid inlets, three fluid outlets in the upper part, and three fluid conduits extending from respective inlets to respective outlets.

- 5 In use water, resin and catalyst are pumped through respective conduits at selected times, and enter a channel in the rock bolt. Mixing of the catalyst and the resin only occurs after they have entered the rock bolt, and as a result there is reduced risk of the drilling apparatus becoming blocked with prematurely hardened resin.
- 10 The system may further comprise a hydraulically driven pump to pump water to a first fluid inlet. It may also comprise pumps to pump resin and catalyst to second and third fluid inlets. The pumps may operate to provide different resin and catalyst flow rates. In addition they may provide precise differential control, to allow different resin catalyst mix ratios for different bolting conditions.

15

The upper part of the injector is insertable within a fixed collar of the rock bolt to make a fluid tight mating between them.

- In a second aspect the invention is a self drilling rock bolt, comprising an elongate body
20 having a leading end with a cutting tip, and around the tip a thread with a coarse pitch. The bolt also has a trailing end with an integral collar to form a fluid connection to a channel that extends axially through the body of the rock bolt to the leading end, and above the collar a thread with a fine pitch. In use a nut is threaded onto the fine pitch and engaged with a drill which operates to drive the nut along the fine pitch thread to abut
25 against the collar during boring. After boring, reversal of the drill drives the nut away from the collar.

The channel within the rock bolt may open in the cutting tip of the bolt.

- 30 The channel within the rock bolt may incorporate a fluid mixer within it. The fluid mixer may comprise a flow restriction.

In another aspect the invention is a rock bolting system comprising a combination of the drilling apparatus and a rock bolt.

In a further aspect the invention is a method of using the system for rock bolting, comprising the steps of:

Attaching a rock bolt to the drilling apparatus for drilling, such that the nut on
5 the rock bolt is secured in the drilling apparatus against rotation, and the upper part of the injector mates with the fluid connection of the rock bolt in a fluid tight manner.

Then operating the drilling apparatus to bore a hole such that rotation of the rock bolt drives the nut against the collar.

And simultaneously pumping water through a first fluid inlet of the injector,
10 through the respective conduit and out, and into the channel in the rock bolt to exit the leading end of the bolt.

When the hole has been completely bored, operation of the drilling apparatus and pumping of the water are ceased before pumping resin and catalyst through respective
15 second and third fluid inlets of the injector, through the respective second and third conduits, out of respective second and third fluid outlets and into the channel in the rock bolt, where they are mixed before exiting the leading end of the bolt. The resin then hardens to bond the rock bolt to the surrounding strata.

A further step in the process then involves operation of the drilling apparatus, in the
20 opposite direction to the direction used to bore the hole, to push the nut into abutment with the opening of the bore hole and to compressively load a local region of strata.

The drilling apparatus is then separated from the rock bolt and removed from the site of
25 the boring and securing operation. The drilling apparatus may then be reloaded with a further bolt and the process is repeated as required.

Brief Description of the Drawings

An example of the present invention will now be described with respect to the
30 accompanying drawings, in which:

Fig.1 is a schematic diagram of a rock bolt installation system in a detached configuration and showing some of the interior detail.

Fig.2 is a schematic diagram of a rock bolt installation system in a use configuration and showing some of the interior detail.

Best Mode of the Invention

Fig. 1 depicts a rock bolt installation system 10 for securing a rock bolt 20 to a strata, such as a coal strata. The system 10 includes hydraulically operated drilling apparatus 30. The drilling apparatus 30 is selectively operable in both clockwise and anticlockwise rotational directions.

The rock bolt 20 has a leading end 21 with a cutting tip 22 and a trailing end 23. The leading end 21 is threaded and has a coarse pitch. Part of the trailing end 23 is also threaded but has a fine pitch 24. The trailing end 23 of the rock bolt 20 also includes a fixed collar 27. A nut 25 is threadingly engageable with the fine pitch 24 of the rock bolt above the collar 27. The nut 25 which has a polygonal profile that mates with the chuck 31 of drill 30.

15

When the nut 25 is rotated toward the trailing end 23, it comes into abutment with the collar 27, as shown in Fig. 1. This abutment prevents the nut 25 from moving further toward the trailing end 23.

The rock bolt 20 has an internal central fluid flow channel 40 formed therein which extends between openings in the leading end 21 and within collar 27 at the trailing end 23. A static mixer is located within the flow channel. The mixer is in the form of a flow restriction 41.

The drilling apparatus 30 includes within it an injector 50. The injector 50 has water inlet 51 to receive water from a water pumping system 61 or water source. Injector 50 also has a resin inlet 52 to receive resin from a resin pumping system 62. And, a catalyst inlet 53 to receive catalyst from a catalyst pumping system 63. The resin pumping system 62 and catalyst pumping system 63 use pumps which are resistant to the aggressive chemical nature of the resin. These pumping systems 62 and 63 permit different resin and catalyst flow rates to be provided, with precise differential control, to allow different resin catalyst mixes for different bolting conditions.

30

The upper end 57 of the injector 50 is insertable within the fixed collar 27 of the rock bolt 20. The connection between the projection 57 and the collar 27, when the projection is inserted into the skirt, is fluid tight.

5 The operation of the system 10 will now be described with reference to Fig. 2. Within drill 30 a water flow conduit 71 carries water between inlet 51 and the upper end 57 of injector 50. Likewise flow conduits 72 and 73 extend from the resin 52 and catalyst 53 inlets to carry resin and catalyst to the upper end of injector 50. Since the resin is unable to harden until it comes into contact with the catalyst, by providing separate fluid flow
10 conduits for the resin and the catalyst, the risk of the injector head becoming blocked with hard resin is significantly reduced.

When a rock bolt 20 is to be installed into a strata, such as a mine roof, the trailing end 23 of the rock bolt 20 is inserted into the chuck 31 of the drill motor 30, such that the nut
15 25 is seated within the chuck and secured thereto. In this position the upper end 57 of the injector 50 is inserted within the collar 27 of the rock bolt 20.

The cutting tip 22 of the rock bolt 20 is then placed against the coal strata 80 and the drill motor 30 is rotated in an anticlockwise direction. The nut 25 abuts against the collar 27
20 preventing the rock bolt 20 from longitudinal movement relative to the chuck. By simultaneously applying anticlockwise rotation and thrust against the coal strata, the cutting tip 22 of the rock bolt 20 starts to bore a hole within the strata.

During the boring operation, the water pumping system 61 or source delivers water into
25 the conduit 71 of the injector 50. The water passes axially through the injector 50 and out of its upper end 51 before entering into the trailing end 23 of the rock bolt 20. The water passes through channel 40 in the rock bolt 20 and exits from the tip 22 where it assists in dispersing drill cuttings away from the cutting tip 22 of the rock bolt 20, and out of the bore hole. The coarse thread 21 adjacent to the tip 22 of the rock bolt 20 assists with
30 clearing of the rock cuttings, and this improves load transfer between the bolt and the strata after bonding.

When the hole has been completely bored rotation of chuck 31 is ceased. The resin and catalyst pumping systems 62 and 63 are then used to deliver the resin through conduit 72

and a catalyst through separate conduit 73. The resin and catalyst pass through injector 50 and enter into the trailing end 23 of the rock bolt 20. While passing through channel 40 the resin and catalyst are no longer separated from each other, and the static mixer 41 interrupts the flow of the resin and the catalyst, thereby promoting mixing of the catalyst and the resin into a single homogeneous fluid .

The homogenous mixture of resin and catalyst then exits from tip 22 and fills the space between the rock bolt 20 and the adjacent strata 80. The resin quickly sets and hardens, bonding the rock bolt 20 to the strata 80.

10

The nut 25 is then rotated clockwise so that it moves axially along the fine thread 24 of the trailing end 23 of the rock bolt 20. This movement separates the nut 25 from collar 27 and pushes nut 25 firmly into abutment against the opening of the bore hole.

15 By further rotating the nut 25 in a clockwise direction, the nut 25 starts to place the rock bolt 20 into tension. Since the rock bolt 20 is now bonded to the strata 80, a local region of the strata is compressively loaded. This loading secures the roof of the mine and reduces the risk of a roof collapse in that area.

20 The chuck 31 is then released from the rock bolt 20 and drill 30 is removed from the site of the boring and securing operation. The drill 30 and chuck 31 are then reloaded with a further bolt 20 and the process is repeated as required.

25 Although the invention has been described with reference to a specific example, it will be appreciated by those skilled in the art that many variations and modifications are possible. For instance, the rock bolt may be secured to the drill in many different ways, such as by using a threaded connection, a frictional interference such as an expanding collet chuck, or another suitable engagement.

30

Also, instead of a static mixer, many other mechanisms could be employed which promotes non-laminar flow of fluids passing therethrough, and hence mixing to create a homogeneous fluid .

Claims

1. A drilling apparatus for rock bolting with a self-drilling rock bolt, comprising
5 within it a fluid injector having an upper part that mates with a self-drilling rock bolt inserted into the drilling apparatus for boring a hole; wherein the injector includes three fluid inlets, three fluid outlets in the upper part, and three fluid conduits extending from respective inlets to respective outlets.
- 10 2. A drilling apparatus according to claim 1 wherein, in use, water, resin and catalyst are pumped through respective conduits at selected times, and enter a channel in the rock bolt.
3. A drilling apparatus according to claim 1, further comprising a pump to pump
15 water to a first fluid inlet, and pumps to pump resin and catalyst to second and third fluid inlets.
4. A drilling apparatus according to claim 3, wherein the pumps operate to provide
20 different resin and catalyst flow rates.
5. A drilling apparatus according to claim 3, wherein the pumps provide precise
differential control, to allow different resin catalyst mix ratios for different bolting
conditions.
- 25 6. A drilling apparatus according to claim 1, wherein the upper part of the injector is insertable within a fixed collar of the trailing end of the rock bolt to make a fluid tight mating between them.
7. A self drilling rock bolt, comprising an elongate body having a leading end with
30 a cutting tip, and around the tip a thread with a coarse pitch; the bolt also has a trailing end with an integral collar for fluid connection to a channel that extends axially through the body of the rock bolt to the leading end, and above the collar a thread with a fine pitch.

8. A self drilling rock bolt according to claim 7, wherein, in use, a nut is threaded onto the fine pitch and engaged with a drill which operates to drive the nut along the fine pitch thread to abut against the collar during boring.
- 5 9. A self drilling rock bolt according to claim 8, wherein after boring, reversal of the drill drives the nut away from the collar.
- 10 10. A self drilling rock bolt according to claim 7, wherein the trailing end of the rock bolt incorporates a collar that, when installed in the chuck makes a fluid tight connection to an upper part of an injector within the drill.
11. A self drilling rock bolt according to claim 7, wherein the channel within the rock bolt opens in the cutting tip of the bolt.
- 15 12. A self drilling rock bolt according to claim 7, wherein the channel within the rock bolt incorporates a fluid mixer within it.
13. A self drilling rock bolt according to claim 12, wherein the fluid mixer comprises a flow restriction.
- 20 14. A rock bolting system comprising:
a drilling apparatus for rock bolting with a self-drilling rock bolt, comprising within it a fluid injector having an upper part that mates with a self-drilling rock bolt inserted into the drilling apparatus for boring a hole; wherein the injector includes three
25 fluid inlets, three fluid outlets in the upper part, and three fluid conduits extending from respective inlets to respective outlets. a combination of the drilling apparatus and a rock bolt; and,
a self drilling rock bolt, comprising an elongate body having a leading end with a cutting tip, and around the tip a thread with a coarse pitch; the bolt also has a trailing end
30 with an integral collar for fluid connection to a channel that extends axially through the body of the rock bolt to the leading end, and above the collar a thread with a fine pitch.
15. A method of using the system for rock bolting according to claim 14, comprising the steps of:

attaching a rock bolt to the drilling apparatus for drilling, such that the nut on the rock bolt is secured in the drilling apparatus against rotation, and the upper part of the injector mates with the fluid connection of the rock bolt in a fluid tight manner;

5 then operating the drilling apparatus to bore a hole such that rotation of the rock bolt drives the nut against the collar;

and simultaneously pumping water through a first fluid inlet of the injector, through the respective conduit and out, and into the channel in the rock bolt to exit the leading end of the bolt.

10 16. A method according to claim 15 wherein, when the hole has been completely bored, operation of the drilling apparatus and pumping of the water are ceased before pumping resin and catalyst through respective second and third fluid inlets of the injector, through the respective second and third conduits, out of respective second and third fluid outlets and into the channel in the rock bolt, where they are mixed before exiting the
15 leading end of the bolt.

17. A method according to claim 15, comprising a further step of operating the drilling apparatus in the opposite direction to the direction used to bore the hole, to push the nut into abutment with the opening of the bore hole and to compressively load a local
20 region of strata.

1 / 2

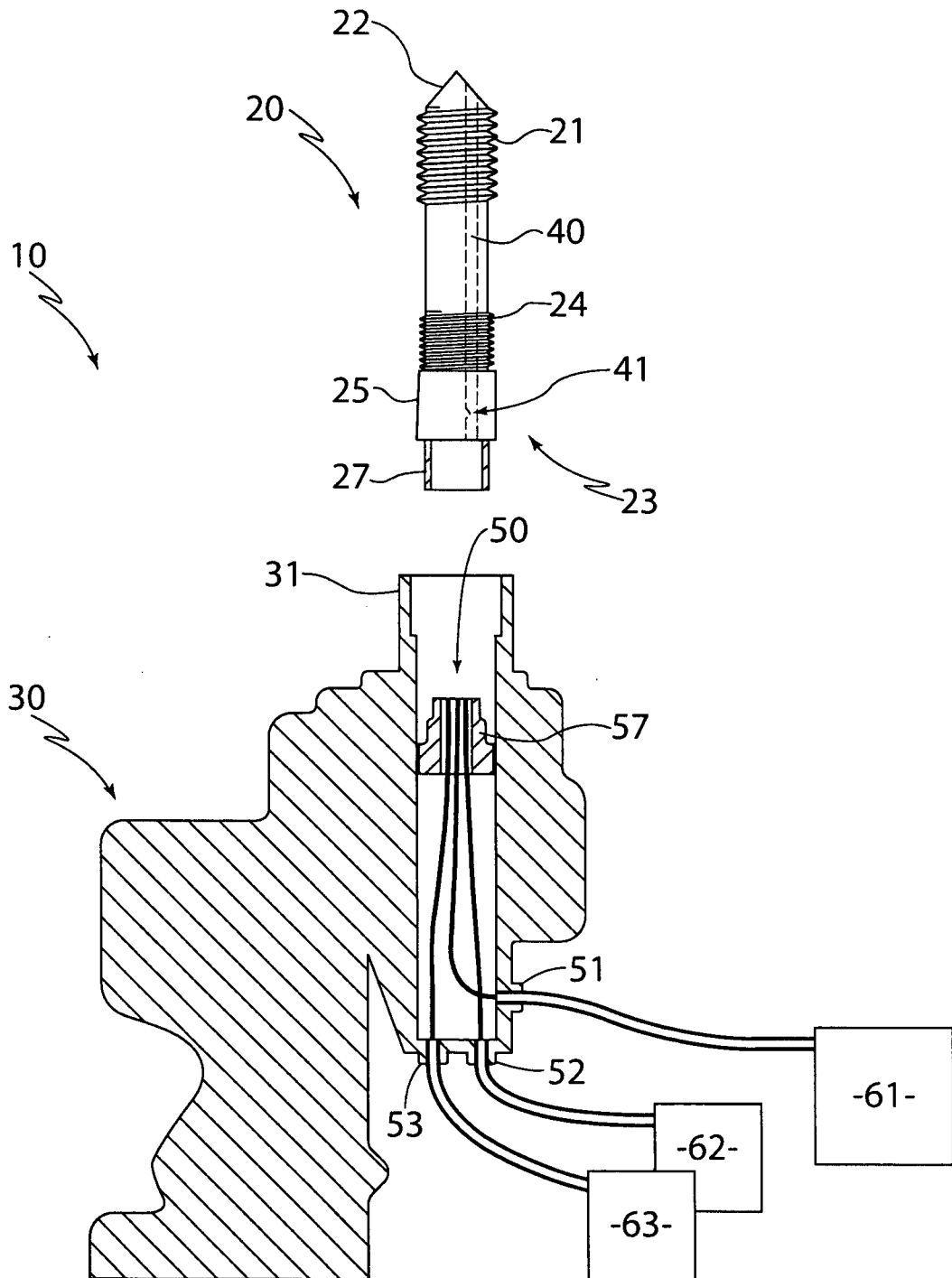

Fig. 1

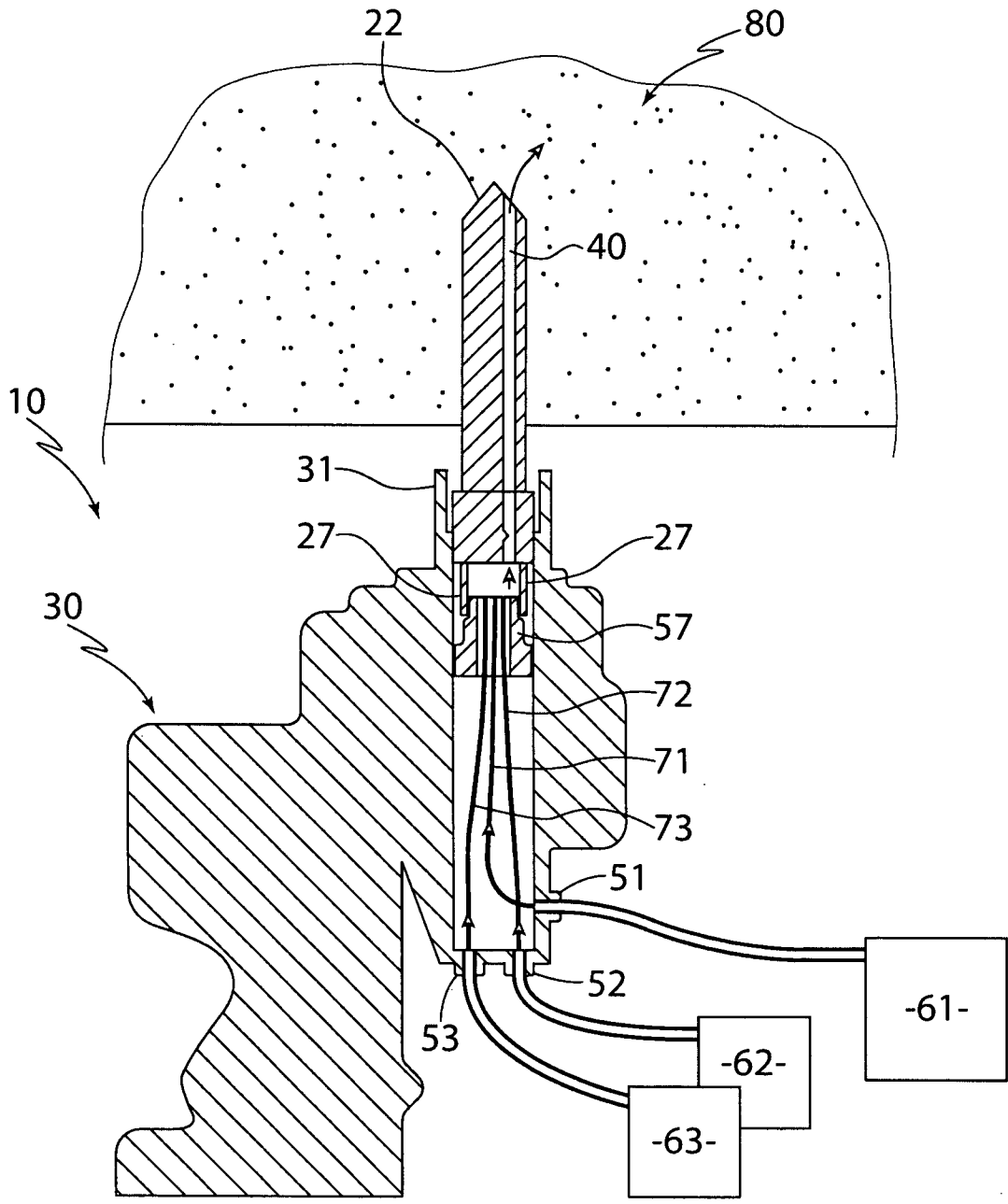

Fig. 2

INTERNATIONAL SEARCH REPORT

International application No.

PCT/AU2008/001838

A. CLASSIFICATION OF SUBJECT MATTER												
Int. Cl.												
<i>E21D 20/00</i> (2006.01) <i>E21D 20/02</i> (2006.01) <i>E21D 21/00</i> (2006.01)												
According to International Patent Classification (IPC) or to both national classification and IPC												
B. FIELDS SEARCHED												
Minimum documentation searched (classification system followed by classification symbols)												
Documentation searched other than minimum documentation to the extent that such documents are included in the fields searched												
Electronic data base consulted during the international search (name of data base and, where practicable, search terms used) WPI, EPODOC <i>E21D 21/00</i> , <i>20/00</i> , <i>20/02</i> key words PUMP+, INJECT+, INLET, FEED+, RESIN+, GROUT+, FLUID, WATER, CATALYST+												
C. DOCUMENTS CONSIDERED TO BE RELEVANT												
Category*	Citation of document, with indication, where appropriate, of the relevant passages	Relevant to claim No.										
A	DE 4024869 A1 (MAGYAR ALUMINIUM [HU]) 14 February 1991 and English abstract retrieved from EPODOC database Abstract and figs 1-7											
A	Patent Abstract of Japan, JP 63035913 A (TOKAI RUBBER IND LTD) 16 February 1988 English abstract retrieved from EPODOC database Abstract											
A	RU 2157454 C2 (CHERNYKH NIKOLAJ GEORGIEVICH) 10 October 2000 and English abstract retrieved from EPODOC database Abstract & fig.											
A	WO 2007/059580 A (GRAY PETER ANDREW) 31 May 2007 Whole document											
<input type="checkbox"/> Further documents are listed in the continuation of Box C <input checked="" type="checkbox"/> See patent family annex												
<p>* Special categories of cited documents:</p> <table border="0"> <tr> <td>"A" document defining the general state of the art which is not considered to be of particular relevance</td> <td>"T" later document published after the international filing date or priority date and not in conflict with the application but cited to understand the principle or theory underlying the invention</td> </tr> <tr> <td>"E" earlier application or patent but published on or after the international filing date</td> <td>"X" document of particular relevance; the claimed invention cannot be considered novel or cannot be considered to involve an inventive step when the document is taken alone</td> </tr> <tr> <td>"L" document which may throw doubts on priority claim(s) or which is cited to establish the publication date of another citation or other special reason (as specified)</td> <td>"Y" document of particular relevance; the claimed invention cannot be considered to involve an inventive step when the document is combined with one or more other such documents, such combination being obvious to a person skilled in the art</td> </tr> <tr> <td>"O" document referring to an oral disclosure, use, exhibition or other means</td> <td>"&" document member of the same patent family</td> </tr> <tr> <td>"P" document published prior to the international filing date but later than the priority date claimed</td> <td></td> </tr> </table>			"A" document defining the general state of the art which is not considered to be of particular relevance	"T" later document published after the international filing date or priority date and not in conflict with the application but cited to understand the principle or theory underlying the invention	"E" earlier application or patent but published on or after the international filing date	"X" document of particular relevance; the claimed invention cannot be considered novel or cannot be considered to involve an inventive step when the document is taken alone	"L" document which may throw doubts on priority claim(s) or which is cited to establish the publication date of another citation or other special reason (as specified)	"Y" document of particular relevance; the claimed invention cannot be considered to involve an inventive step when the document is combined with one or more other such documents, such combination being obvious to a person skilled in the art	"O" document referring to an oral disclosure, use, exhibition or other means	"&" document member of the same patent family	"P" document published prior to the international filing date but later than the priority date claimed	
"A" document defining the general state of the art which is not considered to be of particular relevance	"T" later document published after the international filing date or priority date and not in conflict with the application but cited to understand the principle or theory underlying the invention											
"E" earlier application or patent but published on or after the international filing date	"X" document of particular relevance; the claimed invention cannot be considered novel or cannot be considered to involve an inventive step when the document is taken alone											
"L" document which may throw doubts on priority claim(s) or which is cited to establish the publication date of another citation or other special reason (as specified)	"Y" document of particular relevance; the claimed invention cannot be considered to involve an inventive step when the document is combined with one or more other such documents, such combination being obvious to a person skilled in the art											
"O" document referring to an oral disclosure, use, exhibition or other means	"&" document member of the same patent family											
"P" document published prior to the international filing date but later than the priority date claimed												
Date of the actual completion of the international search 06 March 2009	Date of mailing of the international search report 12 MAR 2009											
Name and mailing address of the ISA/AU AUSTRALIAN PATENT OFFICE PO BOX 200, WODEN ACT 2606, AUSTRALIA E-mail address: pct@ipaustrialia.gov.au Facsimile No. +61 2 6283 7999	Authorized officer SARAVANAMUTHU PONNAMPALAM AUSTRALIAN PATENT OFFICE (ISO 9001 Quality Certified Service) Telephone No : (02) 6283 2070											

INTERNATIONAL SEARCH REPORT

International application No.
PCT/AU2008/001838**Box No. II Observations where certain claims were found unsearchable (Continuation of item 2 of first sheet)**

This international search report has not been established in respect of certain claims under Article 17(2)(a) for the following reasons:

1. Claims Nos.:
because they relate to subject matter not required to be searched by this Authority, namely:

2. Claims Nos.:
because they relate to parts of the international application that do not comply with the prescribed requirements to such an extent that no meaningful international search can be carried out, specifically:

3. Claims Nos.:
because they are dependent claims and are not drafted in accordance with the second and third sentences of Rule 6.4(a)

Box No. III Observations where unity of invention is lacking (Continuation of item 3 of first sheet)

This International Searching Authority found multiple inventions in this international application, as follows:

- (a) Claims 1-6
- (b) Claims 7-13
- (c) Claims 14-17

Please see supplemental sheet.

1. As all required additional search fees were timely paid by the applicant, this international search report covers all searchable claims.
2. As all searchable claims could be searched without effort justifying additional fees, this Authority did not invite payment of additional fees.
3. As only some of the required additional search fees were timely paid by the applicant, this international search report covers only those claims for which fees were paid, specifically claims Nos.:

4. No required additional search fees were timely paid by the applicant. Consequently, this international search report is restricted to the invention first mentioned in the claims; it is covered by claims Nos.:
Claims 1-6 & 14-17

Remark on Protest

- The additional search fees were accompanied by the applicant's protest and, where applicable, the payment of a protest fee.
- The additional search fees were accompanied by the applicant's protest but the applicable protest fee was not paid within the time limit specified in the invitation.
- No protest accompanied the payment of additional search fees.

Supplemental Box

(To be used when the space in any of Boxes I to IV is not sufficient)

Continuation of Box No: III

This International Application does not comply with the requirements of unity of invention because it does not relate to one invention or to a group of inventions so linked as to form a single general inventive concept.

In assessing whether there is more than one invention claimed, I have given consideration to those features which can be considered to potentially distinguish the claimed combination of features from the prior art. Where different claims have different distinguishing features they define different inventions.

This International Searching Authority has found that there are different inventions as follows:

- Claims 1 to 6: It is considered that a drilling apparatus for rock bolting with a self-drilling rock bolt, comprising within it a fluid injector having an upper part that mates with a self-drilling rock bolt inserted into the drilling apparatus for boring a hole; wherein the injector includes three fluid inlets, three fluid outlets in the upper part, and three fluid conduits extending from respective inlets to respective outlets comprises a first distinguishing feature.
- Claims 7 to 13: It is considered that a self-drilling rock bolt, comprising an elongate body having a leading end with a cutting tip, and around the tip a thread with a coarse pitch; the bolt also has a trailing end with an integral collar for fluid connection to a channel that extends axially through the body of the rock bolt to the leading end, and above the collar a thread with a fine pitch comprises a second distinguishing feature.
- Claims 14 to 17: It is considered that rock bolting system and a method of using the system comprising of the drilling apparatus of claims 1 to 6 above and the self-drilling rock bolt of claims 7 to 13 above comprises a third special distinguishing feature

PCT Rule 13.2, first sentence, states that unity of invention is only fulfilled when there is a technical relationship among the claimed inventions involving one or more of the same or corresponding special technical features. PCT Rule 13.2, second sentence, defines a special technical feature as a feature which makes a contribution over the prior art.

The only feature common to all of the claims is a self-drilling rock bolt. However this concept is not novel in the light of your description of the prior art at page 1 lines 15 - 17.

This means that the common feature can not constitute a special technical feature within the meaning of PCT Rule 13.2, second sentence, since it makes no contribution over the prior art.

Because the common feature does not satisfy the requirement for being a special technical feature it follows that it cannot provide the necessary technical relationship between the identified inventions. Therefore the claims do not satisfy the requirement of unity of invention *a posteriori*.

It is possible to search and examine claims 1 to 6 and 14 to 17 without much additional effort, however the additional effort to search and examine the second invention would require additional fees.

INTERNATIONAL SEARCH REPORT

Information on patent family members

International application No.

PCT/AU2008/001838

This Annex lists the known "A" publication level patent family members relating to the patent documents cited in the above-mentioned international search report. The Australian Patent Office is in no way liable for these particulars which are merely given for the purpose of information.

Patent Document Cited in Search Report		Patent Family Member			
DE	4024869	AT	164590	HU	55866
JP	63035913	NONE			
RU	2157454	NONE			
WO	2007059580	AU	2006317519		
Due to data integration issues this family listing may not include 10 digit Australian applications filed since May 2001.					
END OF ANNEX					