



INTERNATIONAL APPLICATION PUBLISHED UNDER THE PATENT COOPERATION TREATY (PCT)

<p>(51) International Patent Classification ⁶ : A46D 1/00</p>	<p>A1</p>	<p>(11) International Publication Number: WO 98/34514 (43) International Publication Date: 13 August 1998 (13.08.98)</p>
<p>(21) International Application Number: PCT/EP98/00718 (22) International Filing Date: 4 February 1998 (04.02.98) (30) Priority Data: 97300797.4 7 February 1997 (07.02.97) EP (34) Countries for which the regional or international application was filed: DE et al. (71) Applicant (for all designated States except US): SMITHKLINE BEECHAM CONSUMER HEALTHCARE GMBH [DE/DE]; Hermannstrasse 7, D-77815 Buhl (DE). (72) Inventor; and (75) Inventor/Applicant (for US only): KRAMER, Hans [DE/DE]; SmithKline Beecham Consumer Healthcare GmbH, Hermannstrasse 7, D-77815 Buhl (DE). (74) Agent: WALKER, Ralph, Francis; SmithKline Beecham, Corporate Intellectual Property, Two New Horizons Court, Brentford, Middlesex TW8 9EP (GB).</p>		<p>(81) Designated States: CA, JP, US, European patent (AT, BE, CH, DE, DK, ES, FI, FR, GB, GR, IE, IT, LU, MC, NL, PT, SE). Published <i>With international search report. Before the expiration of the time limit for amending the claims and to be republished in the event of the receipt of amendments.</i></p>

(54) Title: TOOTHBRUSH BRISTLES

(57) Abstract

A filament having one or more cores of a first polymeric material which is a soft elastomer other than a foamed polyurethane, surrounded by a sheath of a second polymeric material which is harder than the soft elastomer, the core(s) and sheath being bonded together. The filaments are suitable for use as toothbrush bristles.

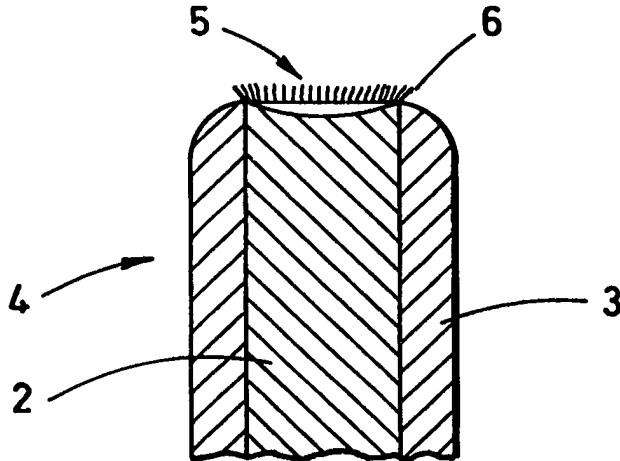

FOR THE PURPOSES OF INFORMATION ONLY

Codes used to identify States party to the PCT on the front pages of pamphlets publishing international applications under the PCT.

AL	Albania	ES	Spain	LS	Lesotho	SI	Slovenia
AM	Armenia	FI	Finland	LT	Lithuania	SK	Slovakia
AT	Austria	FR	France	LU	Luxembourg	SN	Senegal
AU	Australia	GA	Gabon	LV	Latvia	SZ	Swaziland
AZ	Azerbaijan	GB	United Kingdom	MC	Monaco	TD	Chad
BA	Bosnia and Herzegovina	GE	Georgia	MD	Republic of Moldova	TG	Togo
BB	Barbados	GH	Ghana	MG	Madagascar	TJ	Tajikistan
BE	Belgium	GN	Guinea	MK	The former Yugoslav Republic of Macedonia	TM	Turkmenistan
BF	Burkina Faso	GR	Greece	ML	Mali	TR	Turkey
BG	Bulgaria	HU	Hungary	MN	Mongolia	TT	Trinidad and Tobago
BJ	Benin	IE	Ireland	MR	Mauritania	UA	Ukraine
BR	Brazil	IL	Israel	MW	Malawi	UG	Uganda
BY	Belarus	IS	Iceland	MX	Mexico	US	United States of America
CA	Canada	IT	Italy	NE	Niger	UZ	Uzbekistan
CF	Central African Republic	JP	Japan	NL	Netherlands	VN	Viet Nam
CG	Congo	KE	Kenya	NO	Norway	YU	Yugoslavia
CH	Switzerland	KG	Kyrgyzstan	NZ	New Zealand	ZW	Zimbabwe
CI	Côte d'Ivoire	KP	Democratic People's Republic of Korea	PL	Poland		
CM	Cameroon	KR	Republic of Korea	PT	Portugal		
CN	China	KZ	Kazakstan	RO	Romania		
CU	Cuba	LC	Saint Lucia	RU	Russian Federation		
CZ	Czech Republic	LI	Liechtenstein	SD	Sudan		
DE	Germany	LK	Sri Lanka	SE	Sweden		
DK	Denmark	LR	Liberia	SG	Singapore		
EE	Estonia						

TOOTHBRUSH BRISTLES

This invention relates to toothbrushes, in particular to novel materials for toothbrush bristles and toothbrushes which incorporate such bristles.

5 Toothbrushes generally comprise a grip handle and a bristle-bearing head arranged along a longitudinal axis. The head generally has a face from which project bristles. Bristles are generally made of natural bristle materials or more usually in modern times of resilient plastics materials such as nylon. Suitable physical requirements for toothbrush bristle materials are defined in the art, for example in British Standards Institution publication BS 5757:1979 "Specification for toothbrushes". Other
10 publications such as Gerodontics (1988) 4: 45-62 suggest other desirable requirements for toothbrush bristles, such as smooth convex end rounding. Some other materials such as softer rubber fronds have been proposed for use as alternatives to plastics bristle materials, for example as gum massaging elements, e.g. as disclosed in EP 0 360 766 A, or as tooth surface wiper elements as in WO 96/15696.

15 US 3403070 discloses hollow brush filaments which comprise a polyolefin sheath layer with an inner core of a foamed polyurethane, which are made by filling pre-formed hollow filaments with a polyurethane foam. US 3327339 and JP 5123222 discloses brush filaments having an outer sheath of a soft rubber material and a core of a harder plastics material.

20 WO 97/14830 discloses coextruded monofilaments comprising a core material of a first resin and a sheath material of a second resin different from the first resin, with a pocket formed in the end of the monofilament. The monofilaments disclosed therein all comprise cores and sheaths both made of relatively hard polymers.

The booklet "Tynex™ Shapes & Textures Toothbrush Filaments, published by
25 DuPont, discloses filaments for toothbrush bristles having a core of 30% elastomeric polymer with a sheath of the material Tynex™.

There is scope for improvement of toothbrush bristle materials, for example to optimise bristle stiffness, the ability of bristles to transport toothpaste materials to the tooth surfaces of the user, and the softness of the free ends of the bristles. It is an object

of this invention to provide an improved filament material for use as toothbrush bristles, and an improved toothbrush incorporating such bristles.

According to a first aspect of this invention, a filament is provided, comprising one or more cores of a first polymeric material, surrounded by a sheath of a second
5 polymeric material, characterised in that the first polymeric material is a soft elastomer other than a foamed polyurethane, and the second polymeric material is a plastics material which is harder than the soft elastomer, the core(s) and sheath being bonded together.

Preferably there is a single core, generally axially aligned with the filament.

10 The soft elastomeric material may be a known elastomeric material. The term "soft" will be understood in the elastomer art, and generally denotes an elastomeric material softer than the plastics material respectively of the sheath. Typically the hardness of the soft elastomeric material may be 30 Shore A to 60 Shore D, for example 40 Shore A to 95 Shore A.

15 The soft elastomeric material may comprise a single elastomeric material or a mixture, blend or compound of two or more elastomeric materials or of one or more elastomeric materials with other polymeric materials.

Suitable elastomeric materials, particularly for the core of the filaments, include the general class of thermoplastic elastomers, and in particular copolyester block
20 copolymers (such as the known material Hytrel™, supplied by DuPont), polyamide block copolymers such as Pebax™ (supplied by Atochem (FR)), thermoplastic polyurethanes ("TPU") such as Elastollan™ (supplied by Elastogram (DE)), compounds based on styrene block copolymers such as styrene-ethylene-butadiene(or propylene) - styrene ("SEB(or P)S"), or compounds based on styrene-isoprene(or butadiene)-styrene
25 (SI(B)S) such as Thermolast K™ (supplied by Kraiburg Gummiwerk GmbH & Co (DE)), styrene block copolymers such as the Kraton D™ or Kraton G™ series of elastomers (supplied by Shell), polyblends such as ("EPDM/PP") ethylene-propylene-diene monomer / polypropylene such as the Santoprene™ series of elastomers (supplied by AES), soft ethylenevinyl acetate polymers ("EVA") such as Riblene™ (supplied by

EniChem (IT)), ethylene vinyl alcohol polymers ("EVOH") such as Levasint™ (supplied by Bayer (DE)) and soft polyvinyl polymers such as Vinnol™ (supplied by Vinnolit Kunststoff (DE)).

5 A preferred elastomer is the SEBS block copolymer Thermolast K™, being a plasticised modified SEBS polymer compounded with polypropylene, having adhesion toward hard plastics such as polyamides and polyesters.

Suitable plastics materials, for the sheath of the filaments, include polyamides (such as Nylon™, e.g. Nylon 6.12™ and Nylon 6.10™) for example the material commercially available as Tynex™ (supplied by DuPont de Nemours (USA)), linked 10 polyesters such as polyethylene terephthalate ("PET") such as Rynite™ (supplied by DuPont de Nemours (USA)), and polybutyleneterephthalate ("PBT") such as Valox™ (supplied by General Electric Plastics (USA)), polyolefines such as polyethylene e.g. Dowlex™ (supplied by Dow Chemical Corp. (USA)) and polypropylene e.g. Daplen™ (supplied by PCD (AT)), acrylates such as polymethyl methacrylate ("PMMA") such as 15 Lucryl™ (supplied by BASF (DE)), polycarbonates such as Orgalan™ (supplied by Atochem (FR)), polystyrenes such as Polystyrol (supplied by BASF (DE)), polyvinyl polymers such as hard PVC such as Vestolit™ (supplied by Hüls AG (DE)), acrylonitrile butadiene styrene ("ABS") such as Ronfalin™ (supplied by DSM(NL)), styrene acrylonitrile copolymer ("SAN") such as Litac™ (supplied by Mitsui Toatsu Chemicals 20 (JP)) and cellulose esters e.g. cellulose acetate ("CA") such as Tenite™ acetate, cellulose acetate propionate ("CAP") such as Tenite™ propionate, and cellulose acetate butyrate ("CAB") such as Tenite™ butyrate (the latter three supplied by Eastman Chemical Products (US)).

25 It is generally preferred to use respective core and sheath materials which have adhesion toward each other. For example this may be achieved by the use of elastomer and plastics materials which are of similar polarities, e.g. both being polar polymers or both being non polar polymers, so as to facilitate physico-chemical bonding between the core and sheath materials. For example a thermoplastic elastomer such as Hytrel™ may

be used in a filament of this invention as a core, together with a harder plastics material sheath such as a PBT such as Valox™.

5 Additionally or alternatively the elastomeric material and/or the harder plastics material may be chemically modified to encourage these two materials to adhere to each other. With the known classes of elastomeric and plastics materials referred to above, some chemical treatment or modification of the materials may be preferable to achieve bonding between the core and sheath. Such chemical treatment or modification is well within the competence of skilled workers in the elastomer industry, and one suitable treatment or modification to facilitate bonding is for example disclosed in EP 0 393 409
10 A.

For example an EPDM/PP material such as Santoprene™ may be used as a core, together with a polyamide chemically modified with polypropylene e.g. as disclosed in EP 0393409 A. For example a chemically modified thermoplastic elastomer such as a modified SEBS may be used, such as Thermolast K™, as a core, with a polyamide such
15 as Nylon 6.12™ and Nylon 6.10™ especially the material Tynex™.

For *inter alia* this reason, of the above elastomeric materials, thermoplastic elastomers are preferred, and in particular modified compounded styrene block copolymers, especially Thermolast K™, and of the above plastics materials polyamides such as Nylon 6.12™ and Nylon 6.10™ especially the material Tynex™, and polyesters
20 such as polyethylene terephthalate and polybutyleneterephthalate are preferred. A particularly preferred combination of elastomeric material and plastics material is Thermolast K™ and Nylon 6.12™ and Nylon 6.10™, with the elastomeric material as the core.

The filaments may be made by known filament co-extrusion techniques, for
25 example as disclosed in US patent 5313909. The materials of the core and sheath may be of the same colour, or of different colours e.g. to achieve a visual effect. For example the sheath may be transparent or translucent and the core may be coloured or vice versa.

The filaments of the invention, particularly the preferred filaments, have been found to have advantages for use as toothbrush bristle materials.

For use as toothbrush bristles, the filaments may be of circular cross section, although the invention appears to be applicable to filaments of other cross sectional shapes. In a circular section filament there is suitably a single core, preferably also of circular section and coaxial with the filament. However filaments having two or more
5 cores are also within the scope of this invention. Circular section filaments may have a diameter similar to that of presently used toothbrush bristles, although they may in some cases be a little larger in diameter than presently used toothbrush bristles, for example being 0.1 - 0.4 mm, typically around 0.17 - 0.25 mm diameter. The core may for example have a diameter of 10 - 80 % of the overall diameter of the filament, typically 30 - 70 %, preferably 40 - 80 %, more preferably 40 - 70 % of the overall diameter. Toothbrush
10 bristle filaments are typically 8 - 15 mm in length. Suitable proportions of overall diameter, core diameter and length for any desired stiffness of toothbrush bristle, e.g. soft, medium or hard may easily be determined by simple experiment within the competence of those skilled in the art. The filaments may alternatively be of other cross
15 sectional shapes, and the cross sectional shape of the core may be the same as or different to that of the filament itself.

The filaments of the invention may be made into toothbrush bristles by any of the well known methods for making filaments of known types into toothbrush bristles. Toothbrush bristles made from the filaments of the present invention may be fixed into
20 toothbrush heads using any of the well known methods of fixing toothbrush bristles into toothbrush heads, e.g. by using small metal clips jammed into socket holes in the toothbrush head, or by fusing the plastics material of the head around the ends of the bristles. The free ends of bristles made using the filaments of the invention may be subjected to end rounding as is done with conventional toothbrush bristles.

25 Therefore according to a further aspect of this invention there is provided the use of the above-described filaments as toothbrush bristles, toothbrush bristles comprised of the above-described filaments.

According to a further aspect of this invention there is provided a toothbrush characterised in that some or all of its bristles are comprised of the above-described filaments, especially filaments according to the preferred embodiments.

The toothbrush of this aspect of the invention may have all of its bristles made of
5 the filaments of this invention, or alternatively bristles made of the filaments of the invention may be combined in a toothbrush with bristles made of other materials, e.g. conventional, materials, e.g. of polyamides such as Nylon™. In a toothbrush which includes bristles made of the filaments of this invention and bristles made of other
10 materials the different types of filaments may be mixed together in tufts, or alternatively or additionally some tufts may be composed entirely of the filaments of the invention and other tufts may be composed only of bristles of other materials.

An advantage of toothbrush bristles made of the filaments of the invention with an elastomer core is their fatigue characteristics under the wear and tear encountered in use in brushing the teeth. After a period of such use the deformation of the bristle field,
15 e.g. widening, composed of bristles which are made of filaments of this invention, can be much less.

Another advantage of toothbrush bristles made of the filaments of this invention is their better adhesion to the surface of the teeth being brushed, resulting from the friction characteristics of the elastomer core compared with the lower friction surface of
20 the plastics material sheath, and hence a better cleaning effect.

Also it has been found that at the ends of the filaments of this invention, when the core is a softer material than the sheath, particularly when there is good adhesion between the elastomer core and the sheath, as for example when the core is a compounded styrene block copolymer based on SEBS modified to have adhesion to hard
25 plastics, and the plastics material is a polyamide, a small concavity can form in the exposed surface of the core at the free end of the filament, either during manufacture, end rounding or during the wear that occurs during toothbrushing. Also around the rim of this concavity the sheath can fray to surround the concavity with a small fringe of fine fibres of sheath material. These two features are believed to be advantageous, as toothpaste

material can reside in the concavity, and the fine filaments can cause a more gentle brushing action of the bristles on the surfaces of the teeth. In some cases, when there is less adhesion between the core and sheath materials, the sheath material can split and fray away from the core material, so that at the free end of the bristle the sheath material is to a greater extent split longitudinally into fine filaments. This too can be an advantage in giving the bristles soft ends which are gentle on the tooth surfaces.

Other features of the toothbrush of the invention, e.g. the construction and shape of the handle and head etc., may be conventional.

The invention will now be described by way of example only with reference to the accompanying drawings, of which Fig. 1 shows a cross section through a filament of the invention and Fig. 2 shows a longitudinal sectioned view of the end of a toothbrush bristle made of the filaments of the invention, having a concavity at its end.

Referring to Fig. 1, filaments 1 were made, of generally circular cross section, comprising a core 2 also of generally circular cross section, surrounded by a sheath 3. The core 2 is composed of a soft elastomeric, and the sheath 3 is composed of a harder plastics material. The filaments 1 are made by a co-extrusion process by which the core 2 and sheath 3 are bonded together in the filaments 1.

Referring to Fig. 2, the end of a toothbrush bristle 4 is shown in cross sectioned view, having a core 2 and sheath 3, and being made of the filament material described and shown with reference to Fig. 1. At the end of the bristle 4 the free end has been rounded using a conventional bristle end rounding technique. A small concavity 5 has formed at the free end, where the softer elastomer core has become exposed. Around the rim of the concavity 5 the harder plastics material of sheath 3 has split and frayed to form a fringe 6 of small fibres around the core 2 and surrounding the small central concavity 5. The fringe 6 gives the bristle 4 a soft end, and the concavity 5 can accommodate particles (not shown) such as abrasives from a tooth paste material and carry them into close proximity to the surfaces of teeth being cleaned.

Two types of filaments 1 overall were made. In each the core 2 was composed of the soft elastomeric modified SEBS material Thermolast K™ supplied by Gummiwerk

Kraiburg GmbH & Co, and the sheath 3 was composed of the harder plastics material Nylon 6.12™, in the form of Hytrel™. The two types of filaments both had an overall diameter of 0.25 mm, and core diameters of respectively 0.125 mm (type A) and 0.165 mm (type B). The sheath 3 was coloured blue and the core 2 white.

5 In a test, a test toothbrush was made with all of its bristles made of filaments as described above and as shown with respect to Figs. 1 and 2. As a comparison a standard Dr Best Flexible Head Sensitive™ (supplied by SmithKline Beecham Consumer Healthcare GmbH (DE)) was used, and the test toothbrush had a bristle field of identical pattern, bristles of the same length, comparable numbers of bristles per tuft, and a
10 handle identical to the Dr Best™ comparison toothbrush.

The test bristles were subjected to a 4 month intermittent and continuous Ponzini wear test (a testing procedure widely used in the field of toothbrush bristles), and showed excellent non-wear properties.

15 In comparative simulated *in vitro* tooth cleaning tests the test toothbrush showed better cleaning efficiency than the comparison toothbrush, type A with the smaller diameter core proving better than type B after a long period of simulated use.

20 In comparative simulated *in vitro* wear tests the test bristles, both type A and B showed virtually no widening of the bristle field after simulated ca. 5.5 hours of simulated toothbrushing. The comparison Dr Best™ toothbrush showed up to 45% widening of the bristle field as a result of these tests.

Claims:

1. A filament comprising one or more cores of a first polymeric material, surrounded by a sheath of a second polymeric material, characterised in that the first polymeric materials is a soft elastomer other than a foamed polyurethane, and the second
5 polymeric materials is a plastics material which is harder than the soft elastomer, the core(s) and sheath being bonded together.
2. A filament according to claim 1 characterised in that the there is a single core generally axially aligned with the filament.
10
3. A filament according to claim 1 or claim 2 characterised in that the hardness of the soft elastomeric material is 30 Shore A to 60 Shore D.
4. A filament according to any one of claims 1, 2 or 3 characterised in that the
15 elastomeric material for the core of the filaments is a thermoplastic elastomers.
5. A filament according to any one of claims 1 to 4 characterised in that the elastomeric material for the core of the filaments is selected from copolyester block copolymers, polyamide block copolymers, thermoplastic polyurethanes, compounds
20 based on styrene block copolymers, styrene-ethylene-butadiene(or propylene) -styrene, compounds based on styrene-isoprene(or butadiene)-styrene, styrene block copolymers, polyblends of ethylene-propylene-diene monomer / polypropylene, soft ethylenevinyl acetate polymers, ethylene vinyl alcohol polymers, and soft polyvinyl polymers.
- 25 6. A filament according to claim 5 characterised in that the elastomeric material for the core of the filaments is a styrene-ethylene-butadiene -styrene polymer compounded with polypropylene.

7. A filament according to any one of the preceding claims, characterised in that the plastics materials for the sheath of the filaments is selected from polyamides, linked polyesters such as polyethylene terephthalate and polybutyleneterephthalate, polyolefines, acrylates, polycarbonates, polystyrenes, polyvinyllic polymers, ,
5 acrylonitrile butadiene styrene, styrene acrylonitrile copolymer and cellulose esters.
8. A filament according to anyone of the preceding claims characterised in that the respective core and sheath materials have adhesion toward each other.
- 10 9. A filament according to claim 9 characterised in that the elastomer and plastics materials used respectively for the core and sheath are of similar polarities.
10. A filament according to claim 8 characterised in that the elastomeric material and/or the harder plastics material are chemically modified to encourage the elastomeric material and the harder plastics material to adhere to each other.
15
11. A filament according to any one of the preceding claims characterised in that the elastomeric material of the core is a compounded styrene block copolymers, and the plastics material of the sheath is selected from polyamides and polyesters.
20
12. A filament according to any one of the preceding claims characterised in that the core has a diameter of 10 - 80 % of the overall diameter of the filament.
13. A filament according to any one of the preceding claims characterised in that the core has a diameter of 30 - 70 % of the overall diameter of the filament.
25
14. The use of a filaments as claimed in any one of the preceding claims as a toothbrush bristle.

15. A toothbrush bristle comprised of a filament as claimed in any one of claims 1 to 13..

16. A toothbrush bristle according to claim 15 characterised by a concavity in the
5 exposed surface of the core at the free end of the filament.

17. A toothbrush characterised in that some or all of its bristles are bristles as claimed in claim 15 or 16.

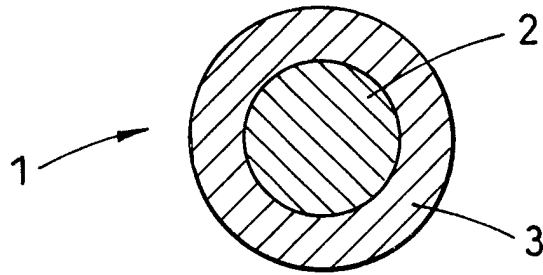

Fig. 1

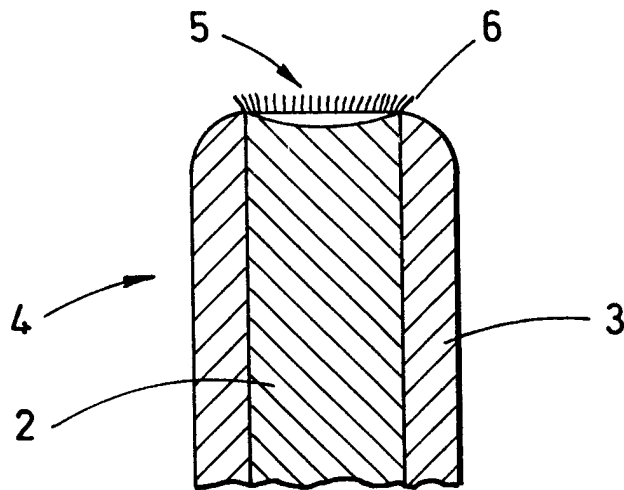

Fig. 2

INTERNATIONAL SEARCH REPORT

International Application No
PCT/EP 98/00718

A. CLASSIFICATION OF SUBJECT MATTER IPC 6 A46D1/00				
According to International Patent Classification(IPC) or to both national classification and IPC				
B. FIELDS SEARCHED				
Minimum documentation searched (classification system followed by classification symbols) IPC 6 A46D				
Documentation searched other than minimum documentation to the extent that such documents are included in the fields searched				
Electronic data base consulted during the international search (name of data base and, where practical, search terms used)				
C. DOCUMENTS CONSIDERED TO BE RELEVANT				
Category °	Citation of document, with indication, where appropriate, of the relevant passages	Relevant to claim No.		
X,P	WO 97 14830 A (DU PONT) 24 April 1997 cited in the application see page 2, line 29 - page 5, line 14; figures ---	1-17		
X A	FR 1 286 226 A (SYNTHÈSE FRANCE) 20 July 1962 see the whole document ---	1-5,8, 12-15,17 6,7,9-11		
A	DE 10 73 434 B (DIETSCHE) 21 January 1960 see column 1, line 1 - column 2, line 47; figures ---	1-17		
--- -/--				
<input checked="" type="checkbox"/> Further documents are listed in the continuation of box C.				
<input checked="" type="checkbox"/> Patent family members are listed in annex.				
° Special categories of cited documents :				
<table style="width: 100%; border: none;"> <tr> <td style="width: 50%; border: none; vertical-align: top;"> "A" document defining the general state of the art which is not considered to be of particular relevance "E" earlier document but published on or after the international filing date "L" document which may throw doubts on priority claim(s) or which is cited to establish the publication date of another citation or other special reason (as specified) "O" document referring to an oral disclosure, use, exhibition or other means "P" document published prior to the international filing date but later than the priority date claimed </td> <td style="width: 50%; border: none; vertical-align: top;"> "T" later document published after the international filing date or priority date and not in conflict with the application but cited to understand the principle or theory underlying the invention "X" document of particular relevance; the claimed invention cannot be considered novel or cannot be considered to involve an inventive step when the document is taken alone "Y" document of particular relevance; the claimed invention cannot be considered to involve an inventive step when the document is combined with one or more other such documents, such combination being obvious to a person skilled in the art. "&" document member of the same patent family </td> </tr> </table>			"A" document defining the general state of the art which is not considered to be of particular relevance "E" earlier document but published on or after the international filing date "L" document which may throw doubts on priority claim(s) or which is cited to establish the publication date of another citation or other special reason (as specified) "O" document referring to an oral disclosure, use, exhibition or other means "P" document published prior to the international filing date but later than the priority date claimed	"T" later document published after the international filing date or priority date and not in conflict with the application but cited to understand the principle or theory underlying the invention "X" document of particular relevance; the claimed invention cannot be considered novel or cannot be considered to involve an inventive step when the document is taken alone "Y" document of particular relevance; the claimed invention cannot be considered to involve an inventive step when the document is combined with one or more other such documents, such combination being obvious to a person skilled in the art. "&" document member of the same patent family
"A" document defining the general state of the art which is not considered to be of particular relevance "E" earlier document but published on or after the international filing date "L" document which may throw doubts on priority claim(s) or which is cited to establish the publication date of another citation or other special reason (as specified) "O" document referring to an oral disclosure, use, exhibition or other means "P" document published prior to the international filing date but later than the priority date claimed	"T" later document published after the international filing date or priority date and not in conflict with the application but cited to understand the principle or theory underlying the invention "X" document of particular relevance; the claimed invention cannot be considered novel or cannot be considered to involve an inventive step when the document is taken alone "Y" document of particular relevance; the claimed invention cannot be considered to involve an inventive step when the document is combined with one or more other such documents, such combination being obvious to a person skilled in the art. "&" document member of the same patent family			
Date of the actual completion of the international search <div style="text-align: center; font-size: 1.2em;">12 June 1998</div>		Date of mailing of the international search report <div style="text-align: center; font-size: 1.2em;">23/06/1998</div>		
Name and mailing address of the ISA European Patent Office, P.B. 5818 Patentlaan 2 NL - 2280 HV Rijswijk Tel. (+31-70) 340-2040, Tx. 31 651 epo nl, Fax: (+31-70) 340-3016		Authorized officer <div style="text-align: center; font-size: 1.2em;">Triantaphillou, P</div>		

INTERNATIONAL SEARCH REPORT

International Application No
PCT/EP 98/00718

C.(Continuation) DOCUMENTS CONSIDERED TO BE RELEVANT		
Category	Citation of document, with indication where appropriate, of the relevant passages	Relevant to claim No.
A	EP 0 303 202 A (GILLETTE CANADA) 15 February 1989 see page 3, line 53 - page 5, line 16; figures & US 5 313 909 A cited in the application ---	1-17
A	PATENT ABSTRACTS OF JAPAN vol. 017, no. 482 (C-1105), 2 September 1993 & JP 05 123222 A (TAKUTO HAYASAKA), 21 May 1993, cited in the application see abstract -----	1-17

INTERNATIONAL SEARCH REPORT

Information on patent family members

International Application No

PCT/EP 98/00718

Patent document cited in search report		Publication date	Patent family member(s)	Publication date
WO 9714830	A	24-04-1997	NONE	
FR 1286226	A	20-07-1962	NONE	
DE 1073434	B		NONE	
EP 0303202	A	15-02-1989	US 4802255 A CA 1297241 A DE 3864950 A	07-02-1989 17-03-1992 24-10-1991