

(19)
(12)

(KR)
(Y1)

(51) 。 Int. Cl. ⁷
B60C 19/08

(45)
(11)
(24)

2001 10 18
20 - 0242585
2001 08 01

(21) 20 - 2001 - 0008527
(22) 2001 03 27

(73) 4 123/10

(72) 4 123/10

:

가 :

(54)

(5)

(6)(6)

(5')

(10)

가

가

1

, , , ,

- 1 가 ,
- 2 ,
- 3 .

2: 5:

10,10':

(事象)

가 .

가

가

가

가

가

가

가

1 2 (6) (5)
(5) (6)(6) (5) (5') (10)

(10)

(10') (5) (5')

8 (5) (6) (10)
(5)

1 (2) (5) (10)

(5) (6)(6) (5') (5') (10)

(5) (10) (5)가 1
가

(10) (5) (10) (5) (10)

가

(57)

1.

(6) (5)
(5) (6)(6) (5) (5') (10)

2.

1 , (10') (5) (5')

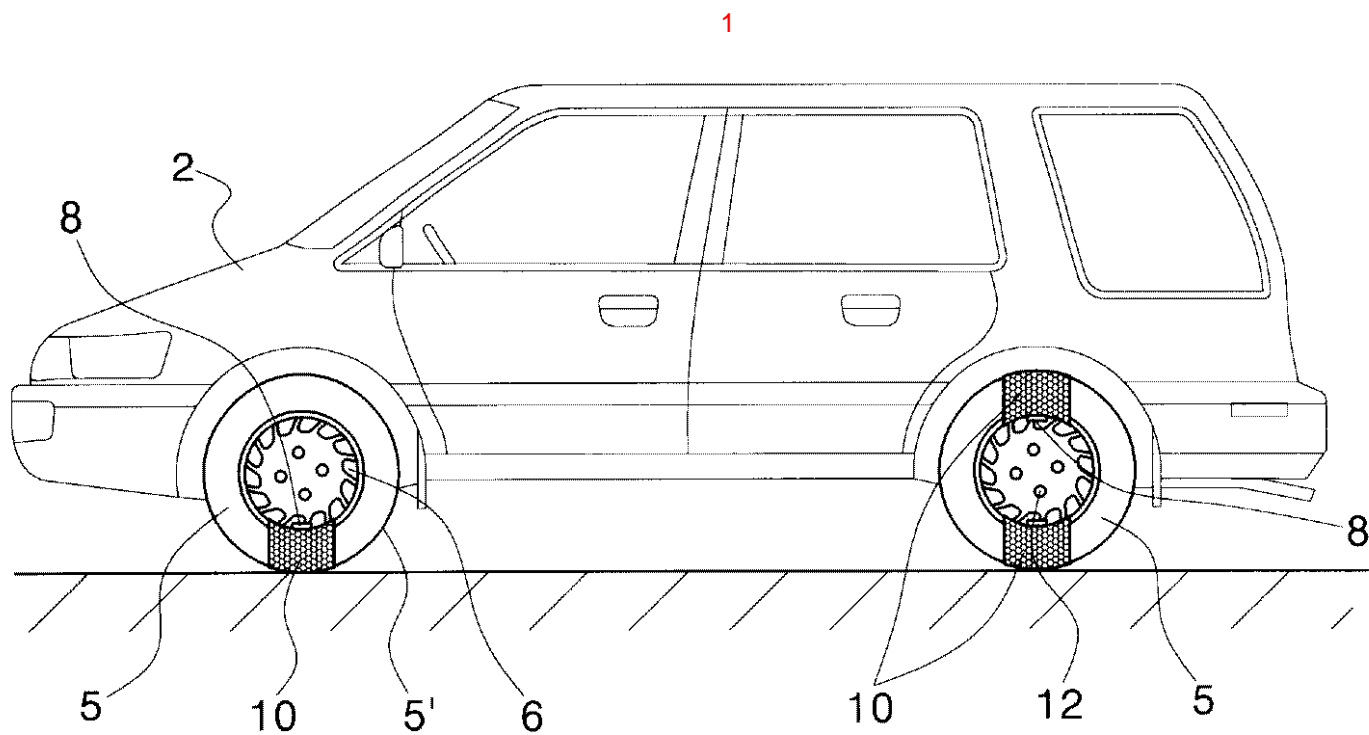

2

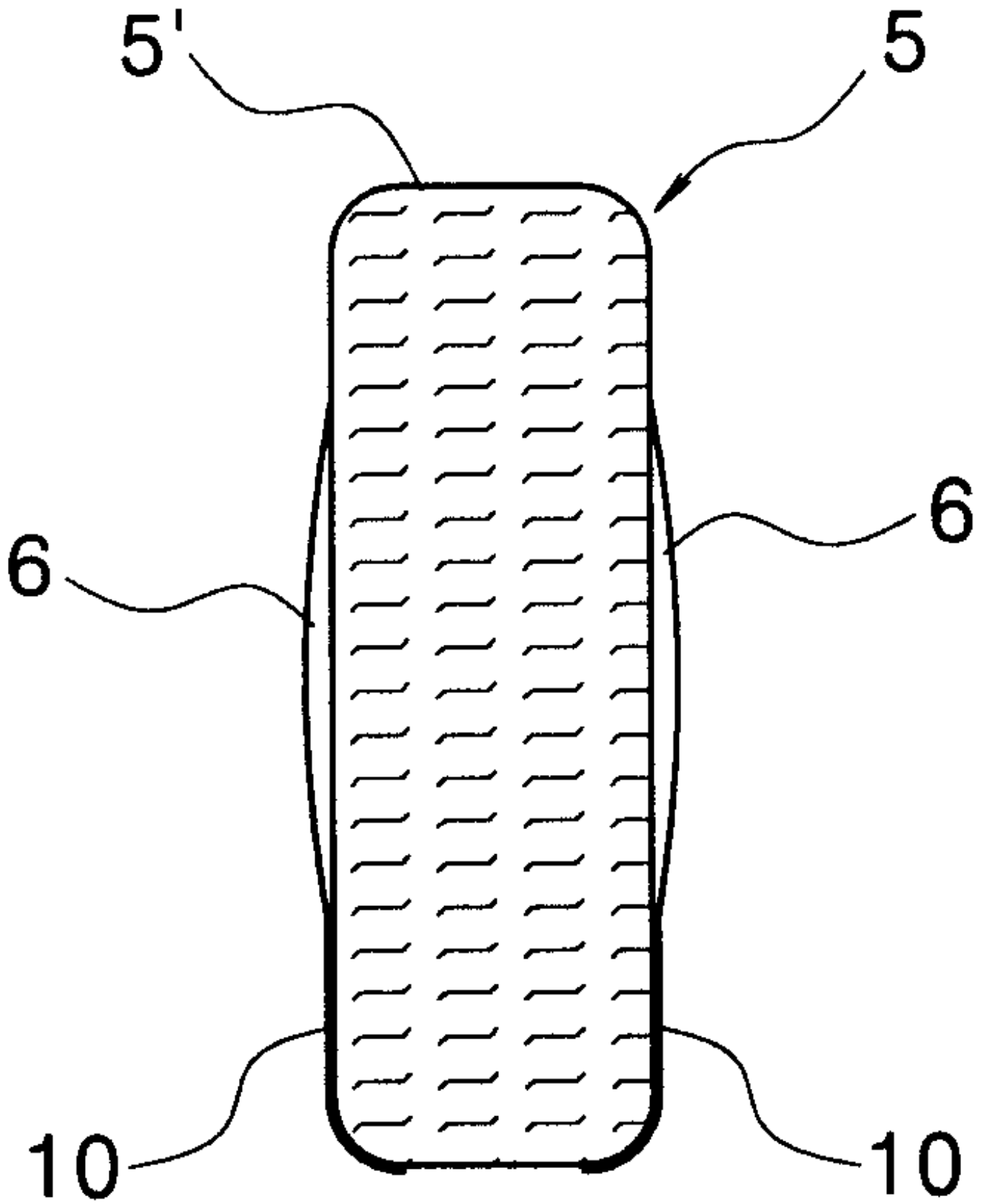

3

