



- (51) **International Patent Classification:**
A61B 17/064 (2006.01) A61B 17/072 (2006.01)
- (21) **International Application Number:**
PCT/US2015/012162
- (22) **International Filing Date:**
21 January 2015 (21.01.2015)
- (25) **Filing Language:** English
- (26) **Publication Language:** English
- (30) **Priority Data:**
14/187,383 24 February 2014 (24.02.2014) US
- (71) **Applicant:** ETHICON ENDO-SURGERY, INC. [US/US]; 4545 Creek Road, Cincinnati, Ohio 45242 (US).
- (72) **Inventors:** SCHELLIN, Emily A.; 11919 Snider Road, Cincinnati, Ohio 45249 (US). VENDELY, Michael J.; 1505 Shaker Run Blvd., Lebanon, Ohio 45036 (US). WEANER, Lauren S.; 7985 Quebec Court, Cincinnati, Ohio 45241 (US). SHELTON, Frederick E., IV; 245 East Main Street, Hillsboro, Ohio 45133 (US). ARONHALT, Taylor W.; 306 Beech Road, Loveland, Ohio 45140 (US). REYNOLDS, Donald L., II; 8464 Bluebird Drive, West Chester, Ohio 45069 (US). TIMMER, Mark D.; 93 Coles Street #1, Jersey City, New Jersey 07302 (US). DONNERS, Jackie J.; 507 Bollen Court, Pennington, New Jersey 08534 (US). BARTON, Trevor J.; 4085 Sharon Park Lane, Cincinnati, Ohio 45241 (US).
- (74) **Agents:** PLANTZ, Bernard F. et al.; Johnson & Johnson, One Johnson & Johnson Plaza, New Brunswick, New Jersey 08933 (US).

- (81) **Designated States** (unless otherwise indicated, for every kind of national protection available): AE, AG, AL, AM, AO, AT, AU, AZ, BA, BB, BG, BH, BN, BR, BW, BY, BZ, CA, CH, CL, CN, CO, CR, CU, CZ, DE, DK, DM, DO, DZ, EC, EE, EG, ES, FI, GB, GD, GE, GH, GM, GT, HN, HR, HU, ID, IL, IN, IR, IS, JP, KE, KG, KN, KP, KR, KZ, LA, LC, LK, LR, LS, LU, LY, MA, MD, ME, MG, MK, MN, MW, MX, MY, MZ, NA, NG, NI, NO, NZ, OM, PA, PE, PG, PH, PL, PT, QA, RO, RS, RU, RW, SA, SC, SD, SE, SG, SK, SL, SM, ST, SV, SY, TH, TJ, TM, TN, TR, TT, TZ, UA, UG, US, UZ, VC, VN, ZA, ZM, ZW.
- (84) **Designated States** (unless otherwise indicated, for every kind of regional protection available): ARIPO (BW, GH, GM, KE, LR, LS, MW, MZ, NA, RW, SD, SL, ST, SZ, TZ, UG, ZM, ZW), Eurasian (AM, AZ, BY, KG, KZ, RU, TJ, TM), European (AL, AT, BE, BG, CH, CY, CZ, DE, DK, EE, ES, FI, FR, GB, GR, HR, HU, IE, IS, IT, LT, LU, LV, MC, MK, MT, NL, NO, PL, PT, RO, RS, SE, SI, SK, SM, TR), OAPI (BF, BJ, CF, CG, CI, CM, GA, GN, GQ, GW, KM, ML, MR, NE, SN, TD, TG).

Declarations under Rule 4.17:

- as to the identity of the inventor (Rule 4.17(i))
- as to applicant's entitlement to apply for and be granted a patent (Rule 4.17(ii))
- as to the applicant's entitlement to claim the priority of the earlier application (Rule 4.17(iii))

Published:

- with international search report (Art. 21(3))

[Continued on next page]

(54) **Title:** IMPLANTABLE LAYERS AND METHODS FOR ALTERING IMPLANTABLE LAYERS FOR USE WITH SURGICAL FASTENING INSTRUMENTS

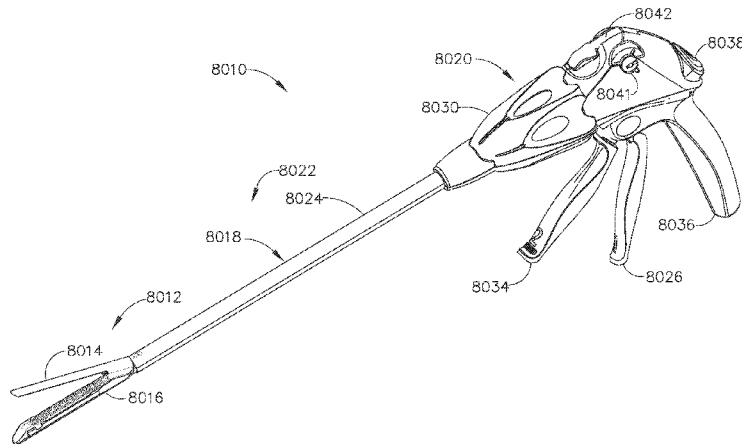

FIG. 1

(57) **Abstract:** A method is disclosed for altering an implantable layer which includes the steps of obtaining an implantable layer comprising a surface at least partially comprised from a material with a glass transition temperature and a melting temperature, heating the surface to a temperature higher than the glass transition temperature and lower than the melting temperature, manipulating the surface, allowing the manipulated surface to cool below the glass transition temperature, and releasing the surface.

WO 2015/126556 A1

- *before the expiration of the time limit for amending the claims and to be republished in the event of receipt of amendments (Rule 48.2(h))*

TITLE**IMPLANTABLE LAYERS AND METHODS FOR ALTERING IMPLANTABLE LAYERS FOR USE WITH SURGICAL FASTENING INSTRUMENTS****BACKGROUND**

[0001] The present invention relates to surgical instruments and, in various arrangements, to surgical stapling and cutting instruments and staple cartridges therefor that are designed to staple and cut tissue.

BRIEF DESCRIPTION OF THE DRAWINGS

[0002] The features and advantages of this invention, and the manner of attaining them, will become more apparent and the invention itself will be better understood by reference to the following description of embodiments of the invention taken in conjunction with the accompanying drawings, wherein:

[0003] FIG. 1 is a left front perspective view of a surgical stapling and severing instrument with a handle portion;

[0004] FIG. 2 is a perspective view of a two-piece knife and firing bar ("E-beam") of the surgical stapling and severing instrument of FIG. 1;

[0005] FIG. 3 is a perspective view of a wedge sled of a staple cartridge of a staple applying assembly;

[0006] FIG. 4 is a longitudinal cross-sectional view of an anvil in a closed position and a staple cartridge comprising a rigid support portion and a compressible tissue thickness compensator illustrated with staples being moved from an unfired position to a fired position during a first sequence;

[0007] FIG. 5 is another cross-sectional view of the anvil and the staple cartridge of FIG. 4 illustrating the anvil in an open position after the firing sequence has been completed;

[0008] FIG. 6 is an exploded perspective view of a tissue thickness compensator and a staple cartridge assembly;

[0009] FIG. 7 is a partial cross-sectional view of the staple cartridge assembly of FIG. 6, illustrating unfired staples positioned in staple cavities of a staple cartridge body and partially embedded in a tissue thickness compensator;

[0010] FIG. 8 is a partial cross-sectional view of the staple cartridge assembly of FIG. 6, illustrating fired staples ejected from the staple cavities of the staple cartridge body and formed against an anvil, and further illustrating the tissue thickness compensator and tissue captured within the staple entrapment area of the formed staples;

[0011] FIG. 9 is a partial perspective view of an end effector of a surgical fastening instrument illustrated with some portions removed and other portions illustrated in cross-section; moreover, a cutting member of the end effector is illustrated in a partially advanced position;

[0012] FIG. 10 is a partial cross-sectional end view of the end effector of FIG. 9 illustrated with patient tissue captured between an anvil and a tissue thickness compensator of the end effector; moreover, staples removably stored within a cartridge body of the end effector are illustrated in an unfired position and the cutting member of the end effector is illustrated in an unadvanced position which is proximal to the tissue thickness compensator;

[0013] FIG. 11 is a partial cross-sectional end view of the end effector of FIG. 9 illustrated with the staples in a fired position and the cutting member in a partially advanced position in which the patient tissue has been at least partially transected;

- [0014] FIG. 12 is a partial cross-sectional end view of the end effector of FIG. 9 illustrated with the staples in a fired position and the cutting member in an advanced position in which at least a portion of the tissue thickness compensator has been transected by the cutting member;
- [0015] FIG. 13 is a perspective view of a fastener cartridge including a tissue thickness compensator;
- [0016] FIG. 14 is a cross-sectional view of the tissue thickness compensator of FIG. 13 illustrating a cutting member positioned relative to a proximal end of the tissue thickness compensator.
- [0017] FIG. 15 is an exploded view of a tissue thickness compensator assembly;
- [0018] FIG. 16 is a perspective view of layer of a tissue thickness compensator assembly;
- [0019] FIG. 17 is a cross-sectional view of the tissue thickness compensator assembly of FIG. 15;
- [0020] FIG. 18 is a cross-sectional perspective view of an assembled tissue thickness compensator assembly and a mold for assembling the same;
- [0021] FIG. 19 is a perspective view of the assembled tissue thickness compensator assembly of FIG. 18;
- [0022] FIG. 20 is a perspective view of a tissue thickness compensator assembly and a mold for assembling the same;
- [0023] FIG. 21 is a perspective view of a tissue thickness compensator assembly and a mold for assembling the same;
- [0024] FIG. 22 is a cross-sectional perspective view of the tissue thickness compensator assembly of FIG. 21 and the mold of FIG. 21 for assembling the same;
- [0025] FIG. 23 is a perspective view of an end effector comprising a tissue thickness compensator;
- [0026] FIG. 24 is a perspective view of the end effector and the tissue thickness compensator of FIG. 23 and a modifying member modifying the tissue thickness compensator;
- [0027] FIG. 25 is a perspective view of the end effector of FIG. 23 comprising the modified tissue thickness compensator of FIG. 24;
- [0028] FIG. 26 is a cross-sectional perspective view of a tissue thickness compensator;
- [0029] FIG. 27 is a cross-sectional perspective view of a mold for modifying the tissue thickness compensator of FIG. 26;
- [0030] FIG. 28 is a cross-sectional perspective view of the tissue thickness compensator of FIG. 26 after modification by the mold of FIG. 27;
- [0031] FIG. 29 is a cross-sectional perspective view of a tissue thickness compensator;
- [0032] FIG. 30 is a cross-sectional perspective view of a mold for modifying the tissue thickness compensator of FIG. 29;
- [0033] FIG. 31 is a cross-sectional perspective view of the tissue thickness compensator of FIG. 29 after modification by the mold of FIG. 30;
- [0034] FIG. 32 is a cross-sectional perspective view of a tissue thickness compensator;
- [0035] FIG. 33 is a cross-sectional perspective view of a mold for modifying the tissue thickness compensator of FIG. 32;

- [0036] FIG. 34 is a cross-sectional perspective view of the tissue thickness compensator of FIG. 32 after modification by the mold of FIG. 33;
- [0037] FIG. 35 is a cross-sectional perspective view of a tissue thickness compensator including a first height;
- [0038] FIG. 36 is a cross-sectional perspective view of the tissue thickness compensator of FIG. 35 after modification to change the first height to a second height;
- [0039] FIG. 37 is a cross-sectional view of a mold for modifying the tissue thickness compensator of FIG. 35;
- [0040] FIG. 38 is a cross-sectional perspective view of a tissue thickness compensator;
- [0041] FIG. 39 is a cross-sectional perspective view the tissue thickness compensator of FIG. 38 after modification;
- [0042] FIG. 40 is a graph illustrating the effect of compression forces on a spring rate of a tissue thickness compensator;
- [0043] FIG. 41 is a cross-sectional perspective view of a tissue thickness compensator;
- [0044] FIG. 42 is a cross-sectional perspective view of a space creator for modifying the tissue thickness compensator of FIG. 41;
- [0045] FIG. 43 is a cross-sectional perspective view of the tissue thickness compensator of FIG. 41 after modification by the space creator of FIG. 42;
- [0046] FIG. 44 is a partial cross-sectional elevational view of a fastener cartridge for use with a surgical instrument including a firing member in accordance with at least one embodiment illustrated with portions removed;
- [0047] FIG. 45 is a partial cross-sectional elevational view depicting a tissue thickness compensator of the fastener cartridge of FIG. 44 being removed from the fastener cartridge and the firing member of FIG. 44 illustrated in a locked-out condition;
- [0048] FIG. 46 is a partial perspective view of the tissue thickness compensator of FIG. 45;
- [0049] FIG. 47 is a partial perspective view a tissue thickness compensator in accordance with at least one embodiment;
- [0050] FIG. 48 is a partial cross-sectional elevational view of an end effector of a surgical instrument comprising a fastener cartridge including the tissue thickness compensator of FIG. 47, a sled, and a firing member supported by the sled illustrated with portions removed;
- [0051] FIG. 49 is a partial cross-sectional elevational view of the end effector of FIG. 48 illustrating the firing member in a partially-fired position;
- [0052] FIG. 50 is a partial cross-sectional elevational view of the end effector of FIG. 48 illustrating the tissue thickness compensator removed from the fastener cartridge and the firing member in a locked-out condition;
- [0053] FIG. 51 is a partial perspective view of a fastener cartridge in accordance with at least one embodiment illustrated with portions removed;
- [0054] FIG. 52 is a perspective view of a sled of the fastener cartridge of FIG. 51;
- [0055] FIG. 53 is a partial perspective view of the fastener cartridge of FIG. 51;
- [0056] FIG. 54 is an elevational view of a sled in accordance with at least one embodiment;
- [0057] FIG. 55 is a perspective view of a sled in accordance with at least one embodiment illustrated in an unlocked configuration;

- [0058] FIG. 56 is a perspective view of the sled of FIG. 55 illustrated in a locked-out configuration;
- [0059] FIG. 57 is a partial cross-sectional elevational view of the sled of FIG. 55 positioned within a fastener cartridge illustrating the sled in its unlocked configuration, a firing member supported by the sled, and a tissue thickness compensator of the fastener cartridge engaged with the sled;
- [0060] FIG. 58 is a partial cross-sectional elevational view of the tissue thickness compensator of FIG. 57 being removed from the fastener cartridge of FIG. 57 which has placed the sled of FIG. 55 in its locked-out configuration and the firing member of FIG. 57 in a locked-out condition;
- [0061] FIG. 59 is a partial cross-sectional elevational view of a sled positioned at the proximal end of a fastener cartridge in accordance with at least one embodiment illustrated with portions removed;
- [0062] FIG. 60 is a partial cross-sectional elevational view of the sled of FIG. 59 illustrated at the distal end of the fastener cartridge;
- [0063] FIG. 61 is a perspective view of a sled in accordance with at least one embodiment;
- [0064] FIG. 62 is a diagram depicting a staple comprising a plurality of barbs in accordance with at least one embodiment, wherein the staple is illustrated in an unformed configuration and a deformed configuration;
- [0065] FIG. 63 is an elevational view of a staple comprising a plurality of barbs in accordance with at least one embodiment, wherein the staple is positioned within a staple cavity in an unfired position;
- [0066] FIG. 64 is an elevational view of a staple including a plurality of barbs in accordance with at least one embodiment;
- [0067] FIG. 65 is an elevational view of a staple including a plurality of barbs in accordance with at least one embodiment;
- [0068] FIG. 66 is an elevational view of a staple including a plurality of barbs in accordance with at least one embodiment;
- [0069] FIG. 67 is an elevational view of a staple including a plurality of barbs in accordance with at least one embodiment;
- [0070] FIG. 68 is an elevational view of the staple including a plurality of barbs in accordance with at least one embodiment, wherein the staple is positioned within a staple cavity in an unfired position;
- [0071] FIG. 69 is a plan view of the staple and the staple cavity of FIG. 68;
- [0072] FIG. 70 is a partial perspective view of a barbed staple leg in accordance with at least one embodiment;
- [0073] FIG. 71 is a partial perspective view of a barbed staple leg of the staple of FIG. 68;
- [0074] FIG. 71A is a cross-sectional plan view of the barbed staple leg of FIG. 71;
- [0075] FIG. 72 is a partial perspective view of a barbed staple leg in accordance with at least one embodiment; and
- [0076] FIG. 73 is a partial perspective view of a barbed staple leg in accordance with at least one embodiment.

DETAILED DESCRIPTION

- [0077] The Applicant of the present application also owns the U.S. Patent Applications identified below which are each herein incorporated by reference in their respective entirety:

U.S. Patent Application Serial No. 12/894,311, entitled SURGICAL INSTRUMENTS WITH RECONFIGURABLE SHAFT SEGMENTS; now U.S. Patent Publication No. 2012/0080496;

U.S. Patent Application Serial No. 12/894,340, entitled SURGICAL STAPLE CARTRIDGES SUPPORTING NON-LINEARLY ARRANGED STAPLES AND SURGICAL STAPLING INSTRUMENTS WITH COMMON STAPLE-FORMING POCKETS; now U.S. Patent Publication No. 2012/0080482;

U.S. Patent Application Serial No. 12/894,327, entitled JAW CLOSURE ARRANGEMENTS FOR SURGICAL INSTRUMENTS; now U.S. Patent Publication No. 2012/0080499;

U.S. Patent Application Serial No. 12/894,351, entitled SURGICAL CUTTING AND FASTENING INSTRUMENTS WITH SEPARATE AND DISTINCT FASTENER DEPLOYMENT AND TISSUE CUTTING SYSTEMS; now U.S. Patent Publication No. 2012/0080502;

U.S. Patent Application Serial No. 12/894,338, entitled IMPLANTABLE FASTENER CARTRIDGE HAVING A NON-UNIFORM ARRANGEMENT; now U.S. Patent Publication No. 2012/0080481;

U.S. Patent Application Serial No. 12/894,369, entitled IMPLANTABLE FASTENER CARTRIDGE COMPRISING A SUPPORT RETAINER; now U.S. Patent Publication No. 2012/0080344;

U.S. Patent Application Serial No. 12/894,312, entitled IMPLANTABLE FASTENER CARTRIDGE COMPRISING MULTIPLE LAYERS; now U.S. Patent Publication No. 2012/0080479;

U.S. Patent Application Serial No. 12/894,377, entitled SELECTIVELY ORIENTABLE IMPLANTABLE FASTENER CARTRIDGE; now U.S. Patent No. 8,393,514;

U.S. Patent Application Serial No. 12/894,339, entitled SURGICAL STAPLING INSTRUMENT WITH COMPACT ARTICULATION CONTROL ARRANGEMENT; now U.S. Patent Publication No. 2012/0080500;

U.S. Patent Application Serial No. 12/894,360, entitled SURGICAL STAPLING INSTRUMENT WITH A VARIABLE STAPLE FORMING SYSTEM; now U.S. Patent Publication No. 2012/0080484;

U.S. Patent Application Serial No. 12/894,322, entitled SURGICAL STAPLING INSTRUMENT WITH INTERCHANGEABLE STAPLE CARTRIDGE ARRANGEMENTS; now U.S. Patent Publication No. 2012/0080501;

U.S. Patent Application Serial No. 12/894,350, entitled SURGICAL STAPLE CARTRIDGES WITH DETACHABLE SUPPORT STRUCTURES; now U.S. Patent Publication No. 2012/0080478;

U.S. Patent Application Serial No. 12/894,383, entitled IMPLANTABLE FASTENER CARTRIDGE COMPRISING BIOABSORBABLE LAYERS; now U.S. Patent Publication No. 2012/0080345;

U.S. Patent Application Serial No. 12/894,389, entitled COMPRESSIBLE FASTENER CARTRIDGE; now U.S. Patent Publication No. 2012/0080335;

U.S. Patent Application Serial No. 12/894,345, entitled FASTENERS SUPPORTED BY A FASTENER CARTRIDGE SUPPORT; now U.S. Patent Publication No. 2012/0080483;

U.S. Patent Application Serial No. 12/894,306, entitled COLLAPSIBLE FASTENER CARTRIDGE; now U.S. Patent Publication No. 2012/0080332;

U.S. Patent Application Serial No. 12/894,318, entitled FASTENER SYSTEM COMPRISING A PLURALITY OF CONNECTED RETENTION MATRIX ELEMENTS; now U.S. Patent Publication No. 2012/0080480;

U.S. Patent Application Serial No. 12/894,330, entitled FASTENER SYSTEM COMPRISING A RETENTION MATRIX AND AN ALIGNMENT MATRIX; now U.S. Patent Publication No. 2012/0080503;

U.S. Patent Application Serial No. 12/894,361, entitled FASTENER SYSTEM COMPRISING A RETENTION MATRIX; now U.S. Patent No. 8,529,600;

U.S. Patent Application Serial No. 12/894,367, entitled FASTENING INSTRUMENT FOR DEPLOYING A FASTENER SYSTEM COMPRISING A RETENTION MATRIX; now U.S. Patent Publication No. 2012/0080485;

U.S. Patent Application Serial No. 12/894,388, entitled FASTENER SYSTEM COMPRISING A RETENTION MATRIX AND A COVER; now U.S. Patent No. 8,474,677;

U.S. Patent Application Serial No. 12/894,376, entitled FASTENER SYSTEM COMPRISING A PLURALITY OF FASTENER CARTRIDGES; now U.S. Patent Publication No. 2012/0080486;

U.S. Patent Application Serial No. 13/097,865, entitled SURGICAL STAPLER ANVIL COMPRISING A PLURALITY OF FORMING POCKETS; now U.S. Patent Publication No. 2012/0080488;

U.S. Patent Application Serial No. 13/097,936, entitled TISSUE THICKNESS COMPENSATOR FOR A SURGICAL STAPLER; now U.S. Patent Publication No. 2012/0080339;

U.S. Patent Application Serial No. 13/097,954, entitled STAPLE CARTRIDGE COMPRISING A VARIABLE THICKNESS COMPRESSIBLE PORTION; now U.S. Patent Publication No. 2012/0080340;

U.S. Patent Application Serial No. 13/097,856, entitled STAPLE CARTRIDGE COMPRISING STAPLES POSITIONED WITHIN A COMPRESSIBLE PORTION THEREOF; now U.S. Patent Publication No. 2012/0080336;

U.S. Patent Application Serial No. 13/097,928, entitled TISSUE THICKNESS COMPENSATOR COMPRISING DETACHABLE PORTIONS; now U.S. Patent Publication No. 2012/0080490;

U.S. Patent Application Serial No. 13/097,891, entitled TISSUE THICKNESS COMPENSATOR FOR A SURGICAL STAPLER COMPRISING AN ADJUSTABLE ANVIL; now U.S. Patent Publication No. 2012/0080489;

U.S. Patent Application Serial No. 13/097,948, entitled STAPLE CARTRIDGE COMPRISING AN ADJUSTABLE DISTAL PORTION; now U.S. Patent Publication No. 2012/0083836;

U.S. Patent Application Serial No. 13/097,907, entitled COMPRESSIBLE STAPLE CARTRIDGE ASSEMBLY; now U.S. Patent Publication No. 2012/0080338;

U.S. Patent Application Serial No. 13/097,861, entitled TISSUE THICKNESS COMPENSATOR COMPRISING PORTIONS HAVING DIFFERENT PROPERTIES; now U.S. Patent Publication No. 2012/0080337;

U.S. Patent Application Serial No. 13/097,869, entitled STAPLE CARTRIDGE LOADING ASSEMBLY; now U.S. Patent Publication No. 2012/0160721;

U.S. Patent Application Serial No. 13/097,917, entitled COMPRESSIBLE STAPLE CARTRIDGE COMPRISING ALIGNMENT MEMBERS; now U.S. Patent Publication No. 2012/0083834;

U.S. Patent Application Serial No. 13/097,873, entitled STAPLE CARTRIDGE COMPRISING A RELEASABLE PORTION; now U.S. Patent Publication No. 2012/0083833;

U.S. Patent Application Serial No. 13/097,938, entitled STAPLE CARTRIDGE COMPRISING COMPRESSIBLE DISTORTION RESISTANT COMPONENTS; now U.S. Patent Publication No. 2012/0080491;

U.S. Patent Application Serial No. 13/097,924, entitled STAPLE CARTRIDGE COMPRISING A TISSUE THICKNESS COMPENSATOR; now U.S. Patent Publication No. 2012/0083835;

U.S. Patent Application Serial No. 13/242,029, entitled SURGICAL STAPLER WITH FLOATING ANVIL; now U.S. Patent Publication No. 2012/0080493;

U.S. Patent Application Serial No. 13/242,066, entitled CURVED END EFFECTOR FOR A STAPLING INSTRUMENT; now U.S. Patent Publication No. 2012/0080498;

U.S. Patent Application Serial No. 13/242,086, entitled STAPLE CARTRIDGE INCLUDING COLLAPSIBLE DECK; now U.S. Patent Publication No. 2013/0075450;

U.S. Patent Application Serial No. 13/241,912, entitled STAPLE CARTRIDGE INCLUDING COLLAPSIBLE DECK ARRANGEMENT; now U.S. Patent Publication No. 2013/0075448;

U.S. Patent Application Serial No. 13/241,922, entitled SURGICAL STAPLER WITH STATIONARY STAPLE DRIVERS; now U.S. Patent Publication No. 2013/0075449;

U.S. Patent Application Serial No. 13/241,637, entitled SURGICAL INSTRUMENT WITH TRIGGER ASSEMBLY FOR GENERATING MULTIPLE ACTUATION MOTIONS; now U.S. Patent Publication No. 2012/0074201;

U.S. Patent Application Serial No. 13/241,629, entitled SURGICAL INSTRUMENT WITH SELECTIVELY ARTICULATABLE END EFFECTOR; now U.S. Patent Publication No. 2012/0074200;

U.S. Application Serial No. 13/433,096, entitled TISSUE THICKNESS COMPENSATOR COMPRISING A PLURALITY OF CAPSULES; now U.S. Patent Publication No. 2012/0241496;

U.S. Application Serial No. 13/433,103, entitled TISSUE THICKNESS COMPENSATOR COMPRISING A PLURALITY OF LAYERS; now U.S. Patent Publication No. 2012/0241498;

U.S. Application Serial No. 13/433,098, entitled EXPANDABLE TISSUE THICKNESS COMPENSATOR; now U.S. Patent Publication No. 2012/0241491;

U.S. Application Serial No. 13/433,102, entitled TISSUE THICKNESS COMPENSATOR COMPRISING A RESERVOIR; now U.S. Patent Publication No. 2012/0241497;

U.S. Application Serial No. 13/433,114, entitled RETAINER ASSEMBLY INCLUDING A TISSUE THICKNESS COMPENSATOR; now U.S. Patent Publication No. 2012/0241499;

U.S. Application Serial No. 13/433,136, entitled TISSUE THICKNESS COMPENSATOR COMPRISING AT LEAST ONE MEDICAMENT; now U.S. Patent Publication No. 2012/0241492;

U.S. Application Serial No. 13/433,141, entitled TISSUE THICKNESS COMPENSATOR COMPRISING CONTROLLED RELEASE AND EXPANSION; now U.S. Patent Publication No. 2012/0241493;

U.S. Application Serial No. 13/433,144, entitled TISSUE THICKNESS COMPENSATOR COMPRISING FIBERS TO PRODUCE A RESILIENT LOAD; now U.S. Patent Publication No. 2012/0241500;

U.S. Application Serial No. 13/433,148, entitled TISSUE THICKNESS COMPENSATOR COMPRISING STRUCTURE TO PRODUCE A RESILIENT LOAD; now U.S. Patent Publication No. 2012/0241501;

U.S. Application Serial No. 13/433,155, entitled TISSUE THICKNESS COMPENSATOR COMPRISING RESILIENT MEMBERS; now U.S. Patent Publication No. 2012/0241502;

U.S. Application Serial No. 13/433,163, entitled METHODS FOR FORMING TISSUE THICKNESS COMPENSATOR ARRANGEMENTS FOR SURGICAL STAPLERS; now U.S. Patent Publication No. 2012/0248169;

U.S. Application Serial No.13/433,167, entitled TISSUE THICKNESS COMPENSATORS; now U.S. Patent Publication No. 2012/0241503;

U.S. Application Serial No. 13/433,175, entitled LAYERED TISSUE THICKNESS COMPENSATOR; now U.S. Patent Publication No. 2012/0253298;

U.S. Application Serial No. 13/433,179, entitled TISSUE THICKNESS COMPENSATORS FOR CIRCULAR SURGICAL STAPLERS; now U.S. Patent Publication No. 2012/0241505;

U.S. Application Serial No. 13/763,028, entitled ADHESIVE FILM LAMINATE; now U.S. Patent Publication No. 2013/0146643;

U.S. Application Serial No. 13/433,115, entitled TISSUE THICKNESS COMPENSATOR COMPRISING CAPSULES DEFINING A LOW PRESSURE ENVIRONMENT; now U.S. Patent Publication No. 2013/0256372;

U.S. Application Serial No. 13/433,118, entitled TISSUE THICKNESS COMPENSATOR COMPRISED OF A PLURALITY OF MATERIALS; now U.S. Patent Publication No. 2013/0256365;

U.S. Application Serial No. 13/433,135, entitled MOVABLE MEMBER FOR USE WITH A TISSUE THICKNESS COMPENSATOR; now U.S. Patent Publication No. 2013/0256382;

U.S. Application Serial No. 13/433,140, entitled TISSUE THICKNESS COMPENSATOR AND METHOD FOR MAKING THE SAME; now U.S. Patent Publication No. 2013/0256368;

U.S. Application Serial No. 13/433,129, entitled TISSUE THICKNESS COMPENSATOR COMPRISING A PLURALITY OF MEDICAMENTS; now U.S. Patent Publication No. 2013/0256367;

U.S. Application Serial No. 11/216,562, entitled STAPLE CARTRIDGES FOR FORMING STAPLES HAVING DIFFERING FORMED STAPLE HEIGHTS, now U.S. Patent No. 7,669,746;

U.S. Application Serial No. 11/714,049, entitled SURGICAL STAPLING DEVICE WITH ANVIL HAVING STAPLE FORMING POCKETS OF VARYING DEPTHS, now U.S. Patent Publication No. 2007/0194082;

U.S. Application Serial No. 11/711,979, entitled SURGICAL STAPLING DEVICES THAT PRODUCE FORMED STAPLES HAVING DIFFERENT LENGTHS, now U.S. Patent No. 8,317,070;

U.S. Application Serial No. 11/711,975, entitled SURGICAL STAPLING DEVICE WITH STAPLE DRIVERS OF DIFFERENT HEIGHT, now U.S. Patent Publication No. 2007/0194079;

U.S. Application Serial No. 11/711,977, entitled SURGICAL STAPLING DEVICE WITH STAPLE DRIVER THAT SUPPORTS MULTIPLE WIRE DIAMETER STAPLES, now U.S. Patent No. 7,673,781;

U.S. Application Serial No. 11/712,315, entitled SURGICAL STAPLING DEVICE WITH MULTIPLE STACKED ACTUATOR WEDGE CAMS FOR DRIVING STAPLE DRIVERS, now U.S. Patent No. 7,500,979;

U.S. Application Serial No. 12/038,939, entitled STAPLE CARTRIDGES FOR FORMING STAPLES HAVING DIFFERING FORMED STAPLE HEIGHTS, now U.S. Patent No. 7,934,630;

U.S. Application Serial No. 13/020,263, entitled SURGICAL STAPLING SYSTEMS THAT PRODUCE FORMED STAPLES HAVING DIFFERENT LENGTHS, now U.S. Patent Publication No. 2011/0147434;

U.S. Application Serial No. 13/118,278, entitled ROBOTICALLY-CONTROLLED SURGICAL STAPLING DEVICES THAT PRODUCE FORMED STAPLES HAVING DIFFERENT LENGTHS, now U.S. Patent Publication No. 2011/0290851;

U.S. Application Serial No. 13/369,629, entitled ROBOTICALLY-CONTROLLED CABLE-BASED SURGICAL END EFFECTORS, now U.S. Patent Publication No. 2012/0138660;

U.S. Application Serial No. 12/695,359, entitled SURGICAL STAPLING DEVICES FOR FORMING STAPLES WITH DIFFERENT FORMED HEIGHTS, now U.S. Patent No. 8,464,923;

U.S. Application Serial No. 13/072,923, entitled STAPLE CARTRIDGES FOR FORMING STAPLES HAVING DIFFERING FORMED STAPLE HEIGHTS, now U.S. Patent No. 8,567,656;

U.S. Application Serial No. 13/766,325, entitled LAYER OF MATERIAL FOR A SURGICAL END EFFECTOR; now U.S. Patent Publication No. 2013/0256380;

U.S. Application Serial No. 13/763,078, entitled ANVIL LAYER ATTACHED TO A PROXIMAL END OF AN END EFFECTOR; now U.S. Patent Publication No. 2013/0256383;

U.S. Application Serial No. 13/763,094, entitled LAYER COMPRISING DEPLOYABLE ATTACHMENT MEMBERS; now U.S. Patent Publication No. 2013/0256377;

U.S. Application Serial No. 13/763,106, entitled END EFFECTOR COMPRISING A DISTAL TISSUE ABUTMENT MEMBER; now U.S. Patent Publication No. 2013/0256378;

U.S. Application Serial No. 13/433,147, entitled TISSUE THICKNESS COMPENSATOR COMPRISING CHANNELS; now U.S. Patent Publication No. 2013/0256369;

U.S. Application Serial No. 13/763,112, entitled SURGICAL STAPLING CARTRIDGE WITH LAYER RETENTION FEATURES; now U.S. Patent Publication No. 2013/0256379;

U.S. Application Serial No. 13/763,035, entitled ACTUATOR FOR RELEASING A TISSUE THICKNESS COMPENSATOR FROM A FASTENER CARTRIDGE; now U.S. Patent Publication No. 2013/0214030;

U.S. Application Serial No. 13/763,042, entitled RELEASABLE TISSUE THICKNESS COMPENSATOR AND FASTENER CARTRIDGE HAVING THE SAME; now U.S. Patent Publication No. 2013/0221063;

U.S. Application Serial No. 13/763,048, entitled FASTENER CARTRIDGE COMPRISING A RELEASABLE TISSUE THICKNESS COMPENSATOR; now U.S. Patent Publication No. 2013/0221064;

U.S. Application Serial No. 13/763,054, entitled FASTENER CARTRIDGE COMPRISING A CUTTING MEMBER FOR RELEASING A TISSUE THICKNESS COMPENSATOR;

U.S. Application Serial No. 13/763,065, entitled FASTENER CARTRIDGE COMPRISING A RELEASABLY ATTACHED TISSUE THICKNESS COMPENSATOR; now U.S. Patent Publication No. 2013/0221065;

U.S. Application Serial No. 13/763,021, entitled STAPLE CARTRIDGE COMPRISING A RELEASABLE COVER;

U.S. Application Serial No. 13/763,078, entitled ANVIL LAYER ATTACHED TO A PROXIMAL END OF AN END EFFECTOR; now U.S. Patent Publication No. 2013/0256383;

U.S. Application Serial No. 13/763,095, entitled LAYER ARRANGEMENTS FOR SURGICAL STAPLE CARTRIDGES; now U.S. Patent Publication No. 2013/0161374;

U.S. Application Serial No. 13/463,147, entitled IMPLANTABLE ARRANGEMENTS FOR SURGICAL STAPLE CARTRIDGES; now U.S. Patent Publication No. 2013/0292398;

U.S. Application Serial No. 13/763,192, entitled MULTIPLE THICKNESS IMPLANTABLE LAYERS FOR SURGICAL STAPLING DEVICES; now U.S. Patent Publication No. 2013/0146642;

U.S. Application Serial No. 13/763,161, entitled RELEASABLE LAYER OF MATERIAL AND SURGICAL END EFFECTOR HAVING THE SAME; now U.S. Patent Publication No. 2013/0153641;

U.S. Application Serial No. 13/763,177, entitled ACTUATOR FOR RELEASING A LAYER OF MATERIAL FROM A SURGICAL END EFFECTOR; now U.S. Patent Publication No. 2013/0146641;

U.S. Application Serial No. 13/763,037, entitled STAPLE CARTRIDGE COMPRISING A COMPRESSIBLE PORTION;

U.S. Application Serial No. 13/433,126, entitled TISSUE THICKNESS COMPENSATOR COMPRISING TISSUE INGROWTH FEATURES; now U.S. Patent Publication No. 2013/0256366;

U.S. Application Serial No. 13/433,132, entitled DEVICES AND METHODS FOR ATTACHING TISSUE THICKNESS COMPENSATING MATERIALS TO SURGICAL STAPLING INSTRUMENTS; now U.S. Patent Publication No. 2013/0256373.

U.S. Application Serial No. 13/851,703, entitled FASTENER CARTRIDGE COMPRISING A TISSUE THICKNESS COMPENSATOR INCLUDING OPENINGS THEREIN;

U.S. Application Serial No. 13/851,676, entitled TISSUE THICKNESS COMPENSATOR COMPRISING A CUTTING MEMBER PATH;

U.S. Application Serial No. 13/851,693, entitled FASTENER CARTRIDGE ASSEMBLIES; and

U.S. Application Serial No. 13/851,684, entitled FASTENER CARTRIDGE COMPRISING A TISSUE THICKNESS COMPENSATOR AND A GAP SETTING ELEMENT.

[0078] Applicant of the present application also owns the following patent applications that were filed on even date herewith and which are each herein incorporated by reference in their respective entireties:

U.S. Patent Application Serial No. _____, entitled STAPLE CARTRIDGE INCLUDING A BARBED STAPLE, Attorney Docket No. END7439USNP;

U.S. Patent Application Serial No. _____, entitled STAPLE CARTRIDGE INCLUDING A BARBED STAPLE, Attorney Docket No. END7440USNP;

U.S. Patent Application Serial No. _____, entitled STAPLE CARTRIDGE INCLUDING A BARBED STAPLE, Attorney Docket No. END7441USNP;

U.S. Patent Application Serial No. _____, entitled IMPLANTABLE LAYERS AND METHODS FOR ALTERING ONE OR MORE PROPERTIES OF IMPLANTABLE LAYERS FOR USE WITH FASTENING INSTRUMENTS, Attorney Docket No. END7348USNP/130324;

U.S. Patent Application Serial No. _____, entitled IMPLANTABLE LAYERS AND METHODS FOR MODIFYING THE SHAPE OF THE IMPLANTABLE LAYERS FOR USE WITH A SURGICAL FASTENING INSTRUMENT, Attorney Docket No. END7347USNP/130325;

U.S. Patent Application Serial No. _____, entitled IMPLANTABLE LAYER ASSEMBLIES, Attorney Docket No. END7346USNP/130326;

U.S. Patent Application Serial No. _____, entitled IMPLANTABLE LAYERS COMPRISING A PRESSED REGION, Attorney Docket No. END7345USNP/130327; and

U.S. Patent Application Serial No. _____, entitled FASTENING SYSTEM COMPRISING A FIRING MEMBER LOCKOUT, Attorney Docket No. END7350USNP/130328.

[0079] Certain exemplary embodiments will now be described to provide an overall understanding of the principles of the structure, function, manufacture, and use of the devices and methods disclosed herein. One or more examples of these embodiments are illustrated in the accompanying drawings. Those of ordinary skill in the art will understand that the devices and methods specifically described herein and illustrated in the accompanying drawings are non-limiting exemplary embodiments and that the scope of the various embodiments of the present invention is defined solely by the claims. The features illustrated or described in connection with one exemplary embodiment may be combined with the features of other embodiments. Such modifications and variations are intended to be included within the scope of the present invention.

[0080] The terms "comprise" (and any form of comprise, such as "comprises" and "comprising"), "have" (and any form of have, such as "has" and "having"), "include" (and any form of include, such as "includes" and "including") and "contain" (and any form of contain, such as "contains" and "containing") are open-ended linking verbs. As a result, a surgical system, device, or apparatus that "comprises," "has," "includes" or "contains" one or more elements possesses those one or more elements, but is not limited to possessing only those one or more elements. Likewise, an element of a system, device, or apparatus that "comprises," "has," "includes" or "contains" one or more features possesses those one or more features, but is not limited to possessing only those one or more features.

[0081] The terms "proximal" and "distal" are used herein with reference to a clinician manipulating the handle portion of the surgical instrument. The term "proximal" referring to the portion closest to the clinician and the term "distal" referring to the portion located away from the clinician. It will be further appreciated that, for convenience and clarity, spatial terms such as "vertical", "horizontal", "up", and "down" may be used herein with respect to the drawings. However, surgical instruments are used in many orientations and positions, and these terms are not intended to be limiting and/or absolute.

[0082] Various exemplary devices and methods are provided for performing laparoscopic and minimally invasive surgical procedures. However, the person of ordinary skill in the art will readily appreciate that the various methods

and devices disclosed herein can be used in numerous surgical procedures and applications including, for example, in connection with open surgical procedures. As the present Detailed Description proceeds, those of ordinary skill in the art will further appreciate that the various instruments disclosed herein can be inserted into a body in any way, such as through a natural orifice, through an incision or puncture hole formed in tissue, etc. The working portions or end effector portions of the instruments can be inserted directly into a patient's body or can be inserted through an access device that has a working channel through which the end effector and elongated shaft of a surgical instrument can be advanced.

[0083] Turning to the Drawings wherein like numerals denote like components throughout the several views, FIG. 1 illustrates an exemplary surgical stapling and severing instrument 8010 suitable for use with a tissue thickness compensator assembly as described in greater detail below. The surgical stapling and severing instrument 8010 can comprise an anvil 8014 which may be repeatedly opened and closed about its pivotal attachment to an elongate staple channel 8016. A staple applying assembly 8012 may comprise the anvil 8014 and the channel 8016, wherein the assembly 8012 can be proximally attached to an elongate shaft 8018 forming an implement portion 8022. When the staple applying assembly 8012 is closed, or at least substantially closed, the implement portion 8022 can present a sufficiently small cross-section suitable for inserting the staple applying assembly 8012 through a trocar. In various circumstances, the assembly 8012 can be manipulated by a handle 8020 connected to the shaft 8018. The handle 8020 can comprise user controls such as a rotation knob 8030 that rotates the elongate shaft 8018 and the staple applying assembly 8012 about a longitudinal axis of the shaft 8018. A closure trigger 8026, which can pivot in front of a pistol grip 8036 to close the staple applying assembly 8012. A closure release button 8038 can be outwardly presented on the handle 8020 when the closure trigger 8026 is clamped such that the release button 8038 can be depressed to unclamp the closure trigger 8026 and open the staple applying assembly 8012, for example. A firing trigger 8034, which can pivot in front of the closure trigger 8026, can cause the staple applying assembly 8012 to simultaneously sever and staple tissue clamped therein. In various circumstances, multiple firing strokes can be employed using the firing trigger 8034 to reduce the amount of force required to be applied by the surgeon's hand per stroke. In certain embodiments, the handle 8020 can comprise one or more rotatable indicator wheels such as, for example, rotatable indicator wheel 8041 which can indicate the firing progress. A manual firing release lever 8042 can allow the firing system to be retracted before full firing travel has been completed, if desired, and, in addition, the firing release lever 8042 can allow a surgeon, or other clinician, to retract the firing system in the event that the firing system binds and/or fails. Additional details on the surgical stapling and severing instrument 8010 and other surgical stapling and severing instruments suitable for use with the present disclosure are described, for example, in U.S. Patent Application No. 13/851,693, entitled FASTENER CARTRIDGE ASSEMBLY, and filed on March 27, 2013, the entire disclosure of which is incorporated herein by reference. Furthermore, powered surgical stapling and severing instruments can also be utilized with the present disclosure. See, for example, U.S. Patent Application Publication No. 2009/0090763 A1, entitled POWERED SURGICAL STAPLING DEVICE, and filed on August 8, 2008, the entire disclosure of which is incorporated herein by reference.

[0084] With reference to FIGS. 2 and 3, a firing assembly such as, for example, firing assembly 9090 can be utilized with the surgical stapling and severing instrument 8010 to advance a wedge sled 9126 which comprises a plurality of

wedges 9204 configured to deploy staples from the staple applying assembly 8012 into tissue captured between the anvil 8014 and the elongate staple channel 8016. Furthermore, an E-beam 9102 at a distal portion of the firing assembly 9090 may facilitate separate closure and firing as well as spacing of the anvil 8014 from the elongate staple channel 8016 during firing. The E-beam 9102 may include a pair of top pins 9110, a pair of middle pins 9112 which may follow portion 9218 of the wedge sled 9126, and a bottom pin or foot 9114, as well as a sharp cutting edge 9116 which can be configured to sever the captured tissue as the firing assembly 9090 is advanced distally. In addition, integrally formed and proximally projecting top guide 9118 and middle guide 9120 bracketing each vertical end of the cutting edge 9116 may further define a tissue staging area 9122 assisting in guiding tissue to the sharp cutting edge 9116 prior to being severed. The middle guide 9120 may also serve to engage and fire the staple applying assembly 8012 by abutting a stepped central member 9124 of the wedge sled 9126 (FIG. 2) that effects staple formation by the staple applying assembly 8012.

[0085] In various circumstances, a staple cartridge can comprise means for compensating for thickness of tissue captured within staples deployed from a staple cartridge. Referring to FIG. 4, a staple cartridge, such as staple cartridge 10000, for example, can be utilized with the surgical stapling and severing instrument 8010 and can include a rigid first portion, such as support portion 10010, for example, and a compressible second portion, such as tissue thickness compensator 10020, for example. The support portion 10010 can comprise a cartridge body and a plurality of staple cavities 10012. A staple 10030, for example, can be removably positioned in each staple cavity 10012. Referring primarily to FIGS. 4 and 5, each staple 10030 can comprise a base 10031 and one or more legs 10032 extending from the base 10031. Prior to the staples 10030 being deployed, the bases 10031 of the staples 10030 can be supported by staple drivers positioned within the support portion 10010 and, concurrently, the legs 10032 of the staples 10030 can be at least partially contained within the staple cavities 10012. In various circumstances, the staples 10030 can be deployed between an unfired position and a fired position such that the legs 10032 move through the tissue thickness compensator 10020, penetrate through a top surface of the tissue thickness compensator 10020, penetrate the tissue T, and contact an anvil positioned opposite the staple cartridge 10000. As the legs 10032 are deformed against the anvil, the legs 10032 of each staple 10030 can capture a portion of the tissue thickness compensator 10020 and a portion of the tissue T within each staple 10030 and apply a compressive force to the tissue. Further to the above, the legs 10032 of each staple 10030 can be deformed downwardly toward the base 10031 of the staple to form a staple entrapment area in which the tissue T and the tissue thickness compensator 10020 can be captured. In various circumstances, the staple entrapment area can be defined between the inner surfaces of the deformed legs 10032 and the inner surface of the base 10031. The size of the entrapment area for a staple can depend on several factors such as the length of the legs, the diameter of the legs, the width of the base, and/or the extent in which the legs are deformed, for example.

[0086] In use, further to the above and referring primarily to FIG. 4, an anvil, such as anvil 8014 of the surgical stapling and severing instrument 8010, can be moved into a closed position opposite the staple cartridge 10000 by depressing the closure trigger 8026 to advance the E-beam 9102. The anvil 8014 can position tissue against the tissue thickness compensator 10020 and, in various circumstances, compress the tissue thickness compensator 10020 against the support portion 10010, for example. Once the anvil 8014 has been suitably positioned, the staples 10030 can be

deployed, as also illustrated in FIG. 4. In various circumstances, as mentioned above, a staple-firing sled 10050, which is similar in many respects to the sled 9126 (See FIG. 3), can be moved from a proximal end of the staple cartridge 10000 toward a distal end 10002, as illustrated in FIG. 5. As the firing assembly 9090 is advanced, the sled 10050 can contact the staple drivers 10040 and lift the staple drivers 10040 upwardly within the staple cavities 10012. In at least one example, the sled 10050 and the staple drivers 10040 can each comprise one or more ramps, or inclined surfaces, which can co-operate to move the staple drivers 10040 upwardly from their unfired positions. As the staple drivers 10040 are lifted upwardly within their respective staple cavities 10012, the staple drivers 10040 can lift the staples 10030 upwardly such that the staples 10030 can emerge from their staple cavities 10012. In various circumstances, the sled 10050 can move several staples upwardly at the same time as part of a firing sequence.

[0087] As discussed above, and referring to FIG. 5, the staple legs 10032 of the staples 10030 can extend into the compensator 10020 beyond the support portion 10010 when the staples 10030 are in their unfired positions. In various circumstances, the tips of the staple legs 10032, or any other portion of the staple legs 10032, may not protrude through a top tissue-contacting surface 10021 of the tissue thickness compensator 10020 when the staples 10030 are in their unfired positions. In certain circumstances, the tips of the staple legs 10032 can comprise sharp tips which can incise and penetrate the tissue thickness compensator 10020.

[0088] In various circumstances, it may be preferable to prevent and/or limit frictional forces between a tissue thickness compensator and a staple. Referring now to FIGS. 6-8, a tissue thickness compensator 20220 for use with a staple cartridge assembly 20200 can include a plurality of clearance apertures 20224 extending at least partially through the tissue thickness compensator 20220. In various circumstances, the staple cartridge assembly 20200 can include a staple cartridge body 20210 and a tissue thickness compensator 20220 releasably secured relative to the staple cartridge body 20210. The cartridge body 20210 can include a cartridge deck 20211 and a plurality of staple cavities 20212 defined through the cartridge deck 20211 and into the body of the staple cartridge body 20210, for example. Staples 20230 can be removably positioned in the staple cavities 20212, for example. The tissue thickness compensator 20220 can include a tissue-contacting surface 20221 (FIG. 7) and a deck-contacting surface 20222 (FIG. 6). The deck-contacting surface 20222 can be releasably positioned against the deck 20211 of the cartridge body 20210, for example, and the tissue-contacting surface 20221 can be positioned against tissue T to be stapled, for example. Clearance apertures 20224 can extend through the deck-contacting surface 20222 and into the tissue thickness compensator 20220 and may comprise holes, slits, gaps, bores, openings, and/or cleared pathways, for example, within the tissue thickness compensator 20220.

[0089] Referring primarily to FIGS. 7 and 8, staples 20230 can be positioned in the staple cavities 20212 of the cartridge body 20210. Each staple 20230 can include a base 20231 and a pair of staple legs 20232, for example, which can extend from the base 20231. Each staple leg 20232 can extend from opposite ends of the base 20231. Referring primarily to FIG. 7, one or more of the clearance apertures 20224 in the tissue thickness compensator 20220 can include an opening in the deck-contacting surface 20222. The opening of a clearance aperture 20224 can be aligned with a corresponding staple leg 20232 that is positioned in a staple cavity 20212. For example, a single staple leg 20232 can be aligned with the opening of a single clearance aperture 20224 when the tissue thickness compensator 20220 is secured relative to the cartridge body 20210. In certain circumstances, a staple leg 20232 can extend into

each clearance aperture 20224, such that at least a portion of the staple 20230 is embedded in the tissue thickness compensator 20220, for example. For example, referring primarily to FIG. 7, a staple 20230 can include a first staple leg 20232a and a second staple leg 20232b. Furthermore, the tissue thickness compensator 20220 can include a first clearance aperture 20224a aligned with the first staple leg 20232a, and a second clearance aperture 20224b aligned with the second staple leg 20232b, for example. Prior to deployment of the staple 20230, the first staple leg 20232a can extend partially through the first clearance aperture 20224a, and the second staple leg 20232b can extend partially through the second clearance aperture 20224b, for example. The tissue thickness compensator 20220 can include additional clearance apertures 20224 that are not aligned with staple legs 20232, for example. In certain circumstances, the staple cartridge assembly 20200 can include additional staples 20230 and/or staple legs 20232 that are not aligned with clearance apertures 20224, for example.

[0090] The staples 20230 can be moveable from an unfired configuration (FIG. 7) to a fired configuration (FIG. 8). Each staple 20230 can be moved along a staple axis when moving between the unfired configuration and the fired configuration. When in the unfired configuration, the staple legs 20232 can extend from the staple cavities 20212 and into the tissue thickness compensator 20220, for example. The staple legs 20232 can be partially embedded in the tissue thickness compensator 20220 when the staples 20230 are in the unfired configuration, for example. Furthermore, at least a portion of the staple legs 20232 can be aligned with and/or positioned within the clearance apertures 20224 of the tissue thickness compensator 20220 when the staples are in the unfired configuration, for example. In other circumstances, the staple legs 20232 can be positioned entirely within the staple cavity 20212 when in the unfired configuration, and can be aligned with the clearance apertures 20224 positioned above the cartridge deck 20211 (FIG. 6), for example.

[0091] The staples 20230 can move from the unfired configuration (FIG. 7) to the fired configuration (FIG. 8) during a firing stroke, as described herein. A staple driver 20240 can be positioned within each staple cavity 20212. The staple driver 20240 within each staple cavity 20212 can be pushed toward the cartridge deck 20211 (FIG. 6), for example, to drive the staple 20230 into tissue T and toward an anvil 20260 (FIG. 8) which can be similar in many respects to other anvils described herein such as, for example, the anvil 8014 (FIG. 1). As each staple 20230 moves from the unfired configuration to the fired configuration, the staple legs 20232 can move through the clearance apertures 20224 in the tissue thickness compensator 20220. The clearance apertures 20224 can have a predefined trajectory within the tissue thickness compensator 20220. For example, the clearance apertures 20224 can extend along an axis that is perpendicular to and/or substantially perpendicular to the tissue-contacting surface 20221 (FIG. 7) and/or the deck-contacting surface 20222 (FIG. 6) of the tissue thickness compensator 20220. In other circumstances, the clearance apertures 20224 can extend along an axis that is oriented at an oblique angle relative to the tissue-contacting surface 20221 and/or the deck-contacting surface 20222 of the tissue thickness compensator 20220, for example. In certain circumstances, a group of the clearance apertures 20224 can be parallel. In some circumstances, all of the clearance apertures 20224 within the tissue thickness compensator 20220 can be parallel, for example. The clearance apertures 20224 can comprise a partially curved trajectory and/or a partially linear trajectory. Other characteristics and features of the clearance apertures 20224 are described in greater detail in U.S. Patent Application No.13/851,693, entitled FASTENER CARTRIDGE ASSEMBLY, and filed on March 27, 2013, the entire disclosure

of which is incorporated herein by reference. Methods and techniques for modifying a tissue thickness compensator to include clearance apertures such as, for example, the clearance apertures 20224 are described below in greater detail.

[0092] Referring now to FIGS. 9-12, an end effector 22090 of a surgical instrument similar in many respects to the surgical instrument 8010, for example, can comprise a first jaw including a fastener cartridge assembly 22000 and a second jaw including an anvil 10060. The first jaw can include a staple cartridge channel 10070 which can be configured to removably receive the cartridge assembly 22000. Alternatively, the staple cartridge channel 10070 and the cartridge assembly 22000 can comprise an integral unit. In various circumstances, the anvil 10060 can be moved between an open position and a closed position (FIGS. 9-12). In the open position of the anvil 10060, the anvil 10060 can be positioned on a first side of a patient's tissue T (FIGS. 10-12) and the cartridge assembly 22000 can be positioned on a second, or opposite, side of the tissue T, for example. When the anvil 10060 is moved into its closed position, the anvil 10060 can compress the tissue T against the cartridge assembly 22000. Alternatively, the first jaw including the cartridge assembly 22000 can be moved relative to the anvil 10060. A firing member 10052, which is similar in many respects to the firing assembly 9090 (FIG. 3), can be advanced distally from a proximal end 22001 of the cartridge assembly 22000 toward a distal end 22002 of the cartridge assembly 22000 to eject fasteners, such as staples 22030, for example, removably stored in a cartridge body 22010 of the cartridge assembly 22000 as the firing member 10052 is advanced from the proximal end 22001 toward the distal end 22002 of the cartridge assembly 22000.

[0093] Further to the above, the staples 22030 can be supported by staple drivers 10040 which are movably positioned within staple cavities 22012 defined in the cartridge body 22010. Moreover, the firing member 10052 can be configured to advance a staple-firing sled 10050 distally within the cartridge body 22010 as the firing member 10052 is moved from the proximal end 22001 toward the distal end 22002. In such circumstances, the staple-firing sled 10050 can be configured to lift the staple drivers 10040, and the staples 22030 supported thereon, toward the anvil 10060. In essence, further to the above, the staple drivers 10040 can move the staples 22030 from an unfired position (FIG. 10) to a fired position (FIGS. 11 and 12) wherein the staples 22030 can contact the anvil 10060 and be deformed between an undeformed configuration (FIG. 10) and a deformed configuration (FIGS. 11 and 12). The anvil 10060 can comprise forming pockets 10062 which can be configured to receive and deform the staples 22030. Staples 22030 can be the same as or similar to staples 10030, for example and/or any other staples disclosed herein, and, as such, staples 22030 are not described in greater detail herein. The reader will note, however, that the staples 22030 can comprise any suitable shape and/or suitable dimensions, such as width and/or height, for example, in their undeformed configuration and/or their deformed configuration. For instance, the staples 22030 can, in certain circumstances, comprise a height which does not extend above a deck surface 22011 of the cartridge body 22010 when the staples 22030 are in their unfired positions while, in other circumstances, the staples 22030 can comprise a height in which the legs of the staples 22030 extend upwardly from the deck surface 22011 when the staples 22030 are in their unfired positions such that the legs of the staples 22030 are at least partially embedded in a tissue thickness compensator 22010 of the cartridge assembly 22000.

[0094] With continued reference to the embodiment depicted in FIGS. 9-12, further to the above, the cartridge assembly 22000 can comprise a cartridge body 22010 and a tissue thickness compensator 22020. In various

circumstances, the cartridge body 22010 can be similar to the support portion 10010, for example, in many respects and, as a result, many of such respects are not repeated herein for the sake of brevity. Furthermore, the tissue thickness compensator 22020 can be similar to the tissue thickness compensator 10020, for example, in many respects. Further to the above, the firing member 10052 can include a cutting portion 10053 which can be configured to transect the tissue positioned between the anvil 10060 and the tissue thickness compensator 22020 as the firing member 10052 is advanced distally. In various circumstances, as a result, the firing member 10052 can be configured to concurrently fire the staples 22030 to staple the tissue T and cut the tissue T. In certain circumstances, the firing process can at least partially lead the cutting process. Stated another way, the cutting process can lag the firing process. In such circumstances, a portion of the tissue T can be stapled and then incised.

[0095] As illustrated in FIGS. 9-12, the cartridge body 22010 can include a cartridge knife slot 22015 which can be configured to receive a portion of the firing member 10052 as the firing member 10052 is advanced distally. Further to the above, the anvil 10060 can include an anvil knife slot 10065 which can be configured to receive a portion of the firing member 10052 as the firing member 10052 is advanced distally. In various circumstances, the tissue thickness compensator 22020 can comprise a tissue thickness compensator knife slot 22025 which can be aligned with the anvil knife slot 10065 and the cartridge knife slot 22015 such that the firing member 10052 can pass through the cartridge knife slot 22015, the anvil knife slot 10065, and the tissue thickness compensator knife slot 22025 simultaneously. In various circumstances, the anvil knife slot 10065 can extend over the tissue thickness compensator knife slot 22025 such that the cutting portion 10053 of the firing member 10052 can pass through the cartridge knife slot 22015, the anvil knife slot 10065, and the tissue thickness compensator knife slot 22025 simultaneously. The tissue thickness compensator knife slot 22025 can define a tissue thickness compensator knife path for the cutting portion 10053 wherein the tissue thickness compensator knife path can be parallel to the anvil knife path and the cartridge knife path. In various circumstances, the tissue thickness compensator knife path can be longitudinal while, in certain circumstances, the tissue thickness compensator knife path can be curved. Further to the above, curved end effectors and curved fastener cartridges are disclosed in U.S. Patent Application Publication No. 2008/0169329. The entire disclosure of U.S. Patent Application Serial No. 11/652,164, entitled CURVED END EFFECTOR FOR A SURGICAL STAPLING DEVICE, filed on January 11, 2007, now U.S. Patent Application Publication No. 2008/0169329, is hereby incorporated by reference herein. In such circumstances, a tissue thickness compensator can be curved. In at least one such embodiment, the tissue thickness compensator can be curved to match the curvature of the cartridge body of the fastener cartridge. Methods and techniques for modifying a tissue thickness compensator to include a knife slot such as, for example, the knife slot 22025 are described below.

[0096] Further to the above, referring primarily to FIG. 9, the tissue thickness compensator knife slot 22025 can extend between a first stapling portion 22021a which can be stapled by a first group of staples 22030 and a second stapling portion 22021b which can be stapled by a second group of staples 22030. The knife slot 22025 can releasably connect the first stapling portion 22021a to the second stapling portion 22021b. In use, as illustrated in FIG. 9, the cutting portion 10053 can be advanced distally through the knife slot 22025 to transect the knife slot 22025 and separate the first stapling portion 22021a and the second stapling portion 22021b. In certain circumstances, the knife slot 22025 can comprise a plurality of connectors, or bridges, 22026 which can connect the first stapling portion

22021a and the second stapling portion 22021b prior to being transected by the cutting portion 10053. In various circumstances, the connectors 22026 can have the same thickness as the first stapling portion 22021a and/or the second stapling portion 22021b, at least when the tissue thickness compensator 22020 is in an uncompressed state. In at least one such circumstance, the connectors 22026, the first stapling portion 22021a, and/or the second stapling portion 22021b can be unitarily and integrally formed from a flat, or at least substantially flat, piece of material, for example. In various other circumstances, the first stapling portion 22021a can comprise a first thickness, the second stapling portion 22021b can comprise a second thickness, and the connectors 22026 can comprise a third thickness, wherein one or more of the first thickness, the second thickness, and the third thickness can be different than the other thicknesses.

[0097] The knife slot 22025 can further comprise apertures, such as apertures 22024, for example, defined therein. For instance, the apertures 22024 can be elongate and can extend longitudinally along the knife slot 22025. In various other circumstances, the apertures in the knife slot 22025 can comprise any suitable arrangement. In certain circumstances, the apertures 22024 can comprise perforations positioned intermediate the connectors 22026 which can be formed utilizing a laser cutting operation, for example. In some circumstances, the apertures 22024 can be cut from a sheet of material to form the tissue thickness compensator 22020 such that the apertures 22024 and the connectors 22026 are arranged in an alternating arrangement, for example. In other instances, the tissue thickness compensator 22020 can be molded with apertures 22024 already formed therein. In various circumstances, one or more of the apertures 22024 can comprise through holes, for example. In various circumstances, one or more of the apertures 22024 can comprise clearance apertures, for example. In certain instances, one or more of the apertures 22024 may not comprise through holes and may instead comprise reductions in the thickness of the knife slot 22025, for example. Methods and techniques for modifying a tissue thickness compensator to include apertures such as, for example, the apertures 22024 are described below.

[0098] Further to the above, referring again to FIGS. 9-11, patient tissue can be positioned intermediate the anvil 10060 of the end effector 22090 and the tissue thickness compensator 22020 of the cartridge assembly 22000 when the anvil 10060 is in an open position. When the anvil 10060 is moved into a closed position, a bottom surface, or tissue-contacting surface, 10063 of the anvil 10060 can contact the tissue T and push the tissue T toward a deck surface 22011 of the cartridge body 22010. The tissue T can contact a top surface, or tissue contacting surface, 22021 of the tissue thickness compensator 22020 wherein, when the anvil 10060 is moved into its closed position, the anvil 10060 can press the tissue T against the tissue thickness compensator 22020 and, further to the above, compress the tissue thickness compensator 22020 against the deck surface 22011 of the cartridge body 22010. In various circumstances, the tissue thickness compensator 22020 can comprise a bottom surface 22029 which can abut the deck surface 22011. In some circumstances, a gap may be present between the bottom surface 22029 and the deck surface 22011 before the tissue thickness compensator 22020 is compressed against the cartridge body 22010. In such circumstances, the tissue thickness compensator 22020 may first translate toward the cartridge body 22010 before being compressed thereagainst. When the tissue thickness compensator 22020 is compressed against the cartridge body 22010, in various circumstances, the first stapling portion 22021a and/or the second stapling portion 22021b of the tissue thickness compensator 22020 may move laterally. For instance, the first stapling portion 22021a and/or the

second stapling portion 22021b may move laterally away from the cartridge knife slot 22015. In various circumstances, the connectors 22026 can be configured to inhibit such lateral movement between the first stapling portion 22021a and the second stapling portion 22021b. In various circumstances, referring primarily to FIG. 11, the connectors 22026 can be configured to stretch to permit some relative lateral movement between the first stapling portion 22021a and the second stapling portion 22021b when the anvil 10060 is closed. In the event that the anvil 10060 is reopened, the connectors 22026 can be configured to elastically return, or at least substantially return, to their unstretched configuration and, as a result, pull the first stapling portion 22021a and the second stapling portion 22021b laterally back toward their original positions, illustrated in FIG. 10. Moreover, the anvil 10060 can compress the tissue T when the anvil 10060 is moved into its closed position. In such circumstances, the tissue T may at least partially flow into the apertures 22024.

[0099] Upon reviewing FIGS. 10-12, the reader will appreciate that the knife slot 22025 of the tissue thickness compensator 22020 comprises less material along the longitudinal length thereof than the first stapling portion 22021a and/or the second stapling portion 22021b. Stated another way, a longitudinal cross-section through the first stapling portion 22021a and/or the second stapling portion 22021b would transect a first amount of material while a longitudinal cross-section through the knife slot 22025 would transect a second amount of material which is less than the first amount of material.

[0100] Once the anvil 10060 has been suitably positioned, further to the above, the firing member 10052 can be advanced distally to fire the staples, as illustrated in FIG. 11, and incise the tissue T and the connectors 22026, as illustrated in FIG. 12. Furthermore, the tissue thickness compensator incision force, the tissue incision force, the tissue thickness compensator drag force, and/or the tissue drag force can dull the cutting portion 10053 of the firing member 10052. A dull knife may not be able to transect the tissue T and/or the tissue thickness compensator 22020, for example, according to a preferred manner. With primary reference to FIG. 12, the cutting portion 10053 can comprise a first knife edge zone 10053a, a second knife edge zone 10053b, and/or a third knife edge zone 10053c, for example, wherein the first knife edge zone 10053a is positioned vertically above the second knife edge zone 10053b, and wherein the second knife edge zone 10053b is positioned vertically above the third knife edge zone 10053c, for example. The cutting portion 10053 can comprise any suitable number and/or location of knife edge zones wherein the knife edge zones depicted in FIG. 12 have been selected for the purposes of discussion. Further to the above, the first knife edge zone 10053a can be configured to transect the tissue T while the second knife edge zone 10053b can be configured to transect the tissue thickness compensator 22020. As a result, the first knife edge zone 10053a may experience the tissue incision force and/or the tissue drag force discussed above. Such forces may wear or dull the first knife edge zone 10053a at a first rate. The second knife edge zone 10053b may experience the tissue thickness compensator incision force and/or the tissue thickness compensator drag force discussed above. Such forces may wear or dull the second knife edge zone 10053b at a second rate. In various circumstances, the second rate can be different than the first rate.

[0101] Turning now to FIGS. 13 and 14, a fastener cartridge 22400 can comprise a tissue thickness compensator 22420 which can include a first stapling portion 22421a and a second stapling portion 22421b which are connected by a knife slot 22425. The knife slot 22425 can comprise an angled longitudinal connector 22426. The angled

longitudinal connector 22426 can extend between a proximal end 22401 of the knife slot 22425 and a distal end 22402 of the knife slot 22425. In some circumstances, the angled longitudinal connector 22426 can extend the entire length of the knife slot 22425 while, in other circumstances, the angled longitudinal connector 22426 can extend less than the length of the knife slot 22425. The angled longitudinal connector 22426 can extend between a top surface 22428 of the tissue thickness compensator 22420 and a bottom surface 22429 of the tissue thickness compensator 22420. In some circumstances, the angled longitudinal connector 22426 can extend the entire distance between the top surface 22428 and the bottom surface 22429 while, in other circumstances, the angled longitudinal connector 22426 can extend less than the distance between the top surface 22428 and the bottom surface 22429. In various circumstances, the proximal end of the longitudinal connector 22426 can extend from the top surface 22428 of the tissue thickness compensator while the distal end of the longitudinal connector 22426 can extend from the bottom surface 22429. Alternatively, the distal end of the longitudinal connector 22426 can extend from the top surface 22428 of the tissue thickness compensator while the proximal end of the longitudinal connector 22426 can extend from the bottom surface 22429. In various circumstances, the longitudinal connector 22426 can comprise a thin bridge (i.e. less than the full thickness of the tissue thickness compensator 22420) or a series of thin bridges that join the first stapling portion 22421a which can be stapled by a first group of staples 22030 to the second stapling portion 22421b which can be stapled by a second group of staples 22030, for example. These thin, angled bridges, and/or the longitudinal connector 22426, could distribute the wear across the second knife edge zone 10053b, rather than concentrating it on one spot. In various circumstances, as a result, the wear occurring on the second knife edge zone 10053b may be equal to, or closer to being equal to, the wear occurring at the first knife edge zone 10053a, for example.

[0102] Referring now to FIGS. 15-17, an exemplary tissue thickness compensator assembly 1000 may include a first layer 1002 and a second layer 1004 attachable to the first layer 1002. The tissue thickness compensator assembly 1000 can be utilized with a surgical instrument such as, for example, the surgical instrument 8010 (FIG. 1). In addition, the tissue thickness compensator assembly 1000 can be utilized in a similar manner as and can replace the tissue thickness compensator 22020 of the cartridge assembly 22000 of the end effector 22090 (FIG. 9). For example, the second layer 1004 of the tissue thickness compensator assembly 1000 may include a first portion 1006 which can be positioned on the deck surface 22011 on a first side of the cartridge knife slot 22015 in a similar fashion to the first stapling portion 22021a and a second portion 1008 which can be positioned on the deck surface 22011 on a second side, opposite the first side, of the cartridge knife slot 22015 in a similar fashion to the second stapling portion 22021b (FIGS. 9-11). In various instances, the first portion 1006 and the second portion 1008 of the second layer 1004 can be spaced apart and may comprise a gap 1010 therebetween which can comprise a knife path for the cutting portion 10053 of the firing member 10052 and may extend at least partially over the cartridge knife slot 22015 when the tissue thickness compensator assembly 1000 is assembled with the cartridge end effector 22090. In certain instances, the first layer 1002 can be configured to couple the first portion 1006 and the second portion 1008 and extend at least partially over the gap 1010, as illustrated in FIG. 17, for example.

[0103] In use, tissue T can be captured between the anvil 10060 and a tissue contacting surface 1012 of the first layer 1002. As the firing member 10052 is advanced, a first group of staples 20030 can be deployed to staple the first portion 1006 and a second group of staples can be deployed to staple the second portion 1008. The first and second

groups of staples can be configured to penetrate through a first deck contacting surface 1007 and a second deck contacting surface 1009, respectively, of the second layer 1004, then through the tissue contacting surface 1012 of the first layer, and then through the captured tissue T to contact the pockets 10062 of the anvil 10060. Furthermore, the advancement of the firing member 10052 can cause the cutting portion 10053 to be advanced distally through the gap 1010 of the tissue thickness compensator assembly 1000. The cutting portion 10053 may transect the first layer 1002 while advancing through the gap 1010 thereby separating the first portion 1006 and the second portion 1008 of the second layer 1004.

[0104] Referring again to FIG. 17, the first layer 1002 of the tissue thickness compensator assembly 1000 may comprise a first height H1, the first portion 1006 of the second layer 1004 may comprise a second height H2, and the second portion 1008 of the second layer 1004 may comprise a third height H3. In certain circumstances, as illustrated in FIG. 17, the second height H2 and the third height H3 can be the same or substantially the same. In other circumstances, the second height H2 can be different from the third height H3. In certain circumstances, the first height H1 can be less than the second height H2 and/or the third height H3, as illustrated in FIG. 17. The first layer 1002 of the tissue thickness compensator assembly 1000 may comprise a first density, the first portion 1006 of the second layer 1004 may comprise a second density, and the second portion 1008 of the second layer 1004 may comprise a third density. In certain circumstances, as illustrated in FIG. 17, the second density and the third density can be the same or substantially the same. In other circumstances, the second density can be different from the third density and/or different from the first density of the first layer 1002. The material compositions of the first portion 1006 and the second portion 1008 can be the same, or at least substantially the same. In other circumstances, the material compositions of the first portion 1006 and the second portion 1008 can be different from each other and/or can be different from the material composition of the first layer 1002.

[0105] As described above, repeated use of the cutting portion 10053 to cut tissue T and tissue thickness compensator material may dull the cutting portion 10053. To slow the dulling process, it may be desirable to reduce the tissue thickness compensator material that is cut by the cutting portion 10053. An additional benefit can be a reduction in the forces needed to advance the firing member 10052 distally during a firing stroke. In order to reduce the dulling of the cutting portion 10053, the first layer 1002 can be comprised, at least partially, of a thin film, for example. In such circumstances, the first height H1 can be significantly less than the second height H2 and the third height H3, as illustrated in FIG. 17. In certain circumstances, the first layer 1002 may comprise a uniform, or substantially uniform, height therethrough, as illustrated in FIG. 17. In other circumstances, a gap bridging portion 1014 of the first layer 1002 may extend at least partially over the gap 1010 and may be thinner than the remainder of the first layer 1002. The cutting portion 10053 may transect the gap bridging portion 1014 of the first layer 1002 while advancing through the gap 1010 between the first portion 1006 and the second portion 1008 of the second layer 1004 which may reduce the resistance experienced by the cutting portion 10053 and/or slow the dulling of the cutting portion 10053. In any event, the first layer 1002 can be configured to maintain a coupling engagement with the first portion 1006 and the second portion 1008 of the second layer 1004 prior to being transected, and to present the cutting portion 10053 with a reduced resistance as the cutting portion 10053 is advanced to transect the first layer 1002.

[0106] To further reduce the dulling of the cutting portion 10053 and/or reduce the resistance experienced by the cutting portion 10053, the gap bridging portion 1014 may comprise a perforated segment 1016 along the knife path defined by the gap 1010, as illustrated in FIG. 16. The perforated segment 1016 can include a plurality of perforations 1018 which can be cut into the first layer 1002 prior to the assembly of the first layer 1002 to the second layer 1004, for example. The perforations 1018 can reduce the interaction between the cutting portion 10053 and the first layer 1002 as the cutting portion 10053 is advanced through the knife path defined by the gap 1010, which may slow the dulling of the cutting portion 10053 and/or reduce the resistance experienced by the cutting portion 10053.

[0107] In various circumstances, as described in greater detail below, the tissue thickness compensator assembly 1000 can be comprised of one or more biocompatible materials. In certain circumstances, the first layer 1002 can be comprised of a biocompatible buttress material and/or plastic material, such as polydioxanone (PDS) and/or polyglycolic acid (PGA), for example, and the second layer 1004 can be comprised of a bioabsorbable foam material and/or a compressible haemostatic material, such as oxidized regenerated cellulose (ORC), for example. In certain circumstances, the first layer 1002 can be a thin film comprising a bioabsorbable material such as polyglycolic acid (PGA) which is marketed under the trade name Vicryl, polylactic acid (PLA or PLLA), polydioxanone (PDS), polyhydroxyalkanoate (PHA), poliglecaprone 25 (PGCL) which is marketed under the trade name Monocryl, polycaprolactone (PCL), and/or a composite of PGA, PLA, PDS, PHA, PGCL and/or PCL, for example. In certain circumstances, the first portion 1006 and/or the second portion 1008 of the second layer 1004 can be comprised of a lyophilized foam comprising polylactic acid (PLA) and/or polyglycolic acid (PGA), for example. In certain circumstances, the first portion 1006 and/or the second portion 1008 of the second layer 1004 can be comprised of biocompatible foam which may comprise a porous, open cell foam and/or a porous, closed cell foam.

[0108] Referring again to FIGS. 15 and 17, the first layer 1002 can be at least partially disposed over the second layer 1004 such that the second layer 1004 may be positioned between the first layer 1002 and the deck surface 22011 (FIG. 9) when the tissue thickness compensator assembly 1000 is assembled with the end effector 22090 (FIG. 9). In other circumstances, the first layer 1002 can be positioned beneath the first portion 1006 and the second portion 1008 (not shown) such that the first layer 1002 may be positioned between the second layer 1004 and the deck surface 22011 (FIG. 9) when the tissue thickness compensator assembly 1000 is assembled with the end effector 22090 (FIG. 9). In any event, the first layer 1002 can be attached to a first contacting surface 1020 of the first portion 1006 and a second contacting surface 1022 of the second portion 1008 of the second layer 1004. The first layer 1002 can be attached to the second layer 1004 via a thermal pressing process involving the application of heat and/or pressure, as described in greater detail below. In other circumstances, the first layer 1002 can be attached to the second layer 1004 by a biocompatible adhesive material such as a fibrin and/or protein hydrogel, for example. Other means for attaching the first layer 1002 to the second layer 1004 are contemplated by the present disclosure.

[0109] Referring now to FIGS. 21 and 22, the first layer 1002 can be at least partially embedded into the first portion 1006 and/or the second portion 1008 of the second layer 1004. In such circumstances, the tissue thickness compensator assembly 1000 can be prepared using a mold 1024, for example, as illustrated in FIG. 21. In various instances, an organic solution comprising a polymer such as, for example, polylactic acid (PLA) and/or polyglycolic acid (PGA) can be poured into the mold 1024. The first layer 1002 can be immersed into the organic solution. As

illustrated in FIG. 22, a central shelf 1026 and a central beam 1027 of a mold cover 1028 can trap the first layer 1002 therebetween to ensure that the first layer 1002 remains immersed in the organic solution which can then be lyophilized using conventional lyophilization techniques and/or any other suitable techniques, for example. Upon completion of the lyophilization process, and/or any other suitable process, the mold cover 1028 can be removed and the tissue thickness compensator assembly 1000 can be recovered from the mold 1028.

[0110] As illustrated in FIG. 21, the first layer 1002 of the tissue thickness compensator 1000 can be partially positioned within the first portion 1006 and the second portion 1008 of the second layer 1004. In certain circumstances, the first layer 1002 can be partially positioned within one of the first portion 1006 and the second portion 1008 and attached to a top surface or a bottom surface of the other one of the first portion 1006 and the second portion 1008.

[0111] In certain circumstances, the central beam 1027 and the shelf 1026 can at least partially extend along an axis that is parallel or substantially parallel to the first deck contacting surface 1007 and/or the second deck contacting surface 1009 when the cover 1028 is in a closed configuration with mold 1024, as illustrated in FIG. 22. In such circumstances, the first layer 1002 can be embedded into the first portion 1006 and/or the second portion 1008 such that first layer 1002 is positioned or substantially positioned in a parallel or substantially parallel relationship with the first deck contacting surface 1007 and/or the second deck contacting surface 1009. In other circumstances, although not illustrated, the central beam 1027 and the shelf 1026 can at least partially extend along an axis that is at an oblique angle with the first deck contacting surface 1007 and/or the second deck contacting surface 1008 when the cover 1028 is in a closed configuration with mold 1024. In such circumstances, the first layer 1002 can be embedded into the first portion 1006 and/or the second portion 1008 such that first layer 1002 is positioned or substantially positioned at an oblique angle with respect to the first deck contacting surface 1007 and/or the second deck contacting surface 1009. Other techniques for partially embedding the first layer 1002 into the first portion 1006 and/or the second portion 1008 are contemplated by the present disclosure.

[0112] Referring now to FIGS. 18 and 19, a tissue thickness compensator assembly 1033, which is similar in many respects to the tissue thickness compensator assembly 1000 and the tissue thickness compensator 20020, is illustrated. The tissue thickness compensator assembly 1033 can comprise the first portion 1006 and the second portion 1008 which can be spaced apart and separably coupled together by a plurality of bridging members or connectors 1030 which may extend across the gap 1010 between the first portion 1006 and the second portion 1008. In addition, some or all of the connectors 1030 of the tissue thickness compensator assembly 1033 can be partially embedded into the first portion 1006 and the second portion 1008, as illustrated in FIG. 19. Furthermore, some or all of the connectors 1030 can comprise a first end positioned within the first portion 1006, a second end positioned within the second portion 1008, and a gap bridging portion 1032 therebetween. The gap bridging portion 1032 may extend across the gap 1010 between the first portion 1006 and the second portion 1008, as illustrated in FIG. 19. The connectors 1030 can be spaced apart along the length of the gap 1010 to separably couple the first portion 1006 to the second portion 1008.

[0113] In certain circumstances, the connectors 1030 can be evenly distributed along an axis extending along the gap 1010, as illustrated in FIG. 19. In other circumstances, although not illustrated, the connectors 1030 can be

unevenly distributed along the axis extending along the gap 1010. The cutting portion 10053 can be configured to transect the gap bridging portions 1032 of the connectors 1030 as the cutting portion 10053 is advanced between the first portion 1006 and the second portion 1008 through the knife path defined by the gap 1010. Where the connectors 1030 are unevenly distributed along the axis extending along the first portion 1006 and the second portion, in at least one instance, the connectors 1030 can be disposed in greater frequency and/or in closer proximity to each other at a distal segment of the gap 1010 than at a proximal segment of the gap 1010 such that the cutting portion 10053 may experience an increasing resistance as it is advanced along the knife path defined by the gap 1010. In other circumstances, the connectors 1030 can be disposed in greater frequency and/or in closer proximity to each other at a proximal segment of the gap 1010 than at a distal segment of the gap 1010 such that the cutting portion 10053 may experience a decreasing resistance as it is advanced along the knife path defined by the gap 1010, for example.

[0114] In certain circumstances, the connectors 1030 can extend or substantially extend in a single plane which can be parallel or substantially parallel to the first deck contacting portion 1007 and/or the second deck contacting portion 1009, as illustrated in FIG. 19. In other circumstances, although not illustrated, the connectors 1030 can extend or substantially extend along a plurality of planes which can be parallel or substantially parallel to each other and/or to the first deck contacting portion 1007 and/or the second deck contacting portion 1009.

[0115] Further to the above, some or all of the gap bridging portions 1032 of the connectors 1030 can be thinner than the remainder of their respective connectors 1030 to present the cutting portion 10053 with a reduced resistance as the cutting portion 10053 is advanced to transect the connectors 1030 while maintaining a coupling engagement with the first portion 1006 and the second portion 1008 of the second layer 1004. For example, some or all the connectors 1030 can comprise a dog-bone shape with thicker ends terminating within the first portion 1006 and the second portion 1008 of the second layer 1004 and thinner central portions extending therebetween. In certain circumstances, the connectors 1030 can each be comprised of a piece of suture which may be comprised of bioabsorbable material such as polyglycolic acid (PGA) which is marketed under the trade name Vicryl, polylactic acid (PLA or PLLA), polydioxanone (PDS), polyhydroxyalkanoate (PHA), poliglecaprone 25 (PGCL) which is marketed under the trade name Monocryl, polycaprolactone (PCL), and/or a composite of PGA, PLA, PDS, PHA, PGCL and/or PCL, for example.

[0116] Referring again to FIG. 18, the tissue thickness compensator assembly 1033 can be prepared using a mold 1034. An organic solution comprising a polymer such as, for example, polylactic acid (PLA) and/or polyglycolic acid (PGA) can be poured into the mold 1034. The connectors 1030 can be immersed into the organic solution. As illustrated in FIG. 18, one or more of the connectors 1030 can each be trapped in one or more dedicated slots 1040 on a central shelf 1036 by one or more beams 1039 extending from a mold cover 1038 and configured for mating engagement with the slots 1040 when the mold cover 1038 is in a closed configuration with the mold 1034 to ensure that the connectors 1030 remain immersed in the organic solution. The slots 1040 can be sized to receive or at least partially receive the bridging portions 1032 which can be secured by the beams 1039 when the mold cover 1038 is in the closed configuration with the mold 1034. The ends of the connectors 1030 extending from the gap bridging portions 1032 may freely float in the organic solution. Alternatively, the ends of the connectors 1030 can be secured to sides of the mold 1034, for example. In certain circumstances, the connectors 1030 can be stretched in the organic

solution between the sides of the mold 1034. In other circumstances, the connectors 1030 can be loosely held between the sides of the mold 1034 to extend through the organic solution in a non-linear fashion, for example.

[0117] Further to the above, in various instances, the organic solution can then be lyophilized using conventional lyophilization techniques and/or any other suitable techniques. Upon completion of the lyophilization process, the mold cover 1036 can be removed and the tissue thickness compensator assembly 1033 can be recovered from the mold 1034. As illustrated in FIG. 19, the resulting tissue thickness compensator assembly 1033 includes connectors 1030 partially positioned within the first portion 1006 and the second portion 1008. Other techniques for partially embedding the connectors 1030 into the first portion 1006 and/or the second portion 1008 are contemplated by the present disclosure. The reader will appreciate that the connectors 1030 can be positioned closer to or further away from the deck contacting surfaces 1007 and 1009 by changing the height of the central shelf 1038 and/or depth of the slots 1040.

[0118] Referring now to FIG. 20, a tissue thickness compensator assembly 1042, which may be similar in many respects to the tissue thickness compensator assembly 1033, the tissue thickness compensator assembly 1000, and/or the tissue thickness compensator 20020, is illustrated. The tissue thickness compensator assembly 1042 may comprise the first portion 1006 and the second portion 1008 which can be spaced apart and separably coupled together by a continuous flexible member 1044 which may form a plurality of bridging members or connectors 1046 which may extend across the gap 1010 between the first portion 1006 and the second portion 1008. The continuous flexible member 1044 may include a first end 1048, a second end 1050, and a flexible portion 1052 extending between the first end 1048 and the second end 1050. The flexible portion 1052 can be configured to extend through the first portion 1006 and the second portion 1008 several times, for example in a zigzag pattern, to form the connectors 1046, as illustrated in FIG. 20. The flexible portion 1052 can be passed in a first direction through a distal segment 1054 of the first portion 1006 and a distal segment 1056 of the second portion 1008 to form a first gap bridging portion 1046a across the gap 1010. The flexible portion 1052 can then be looped and passed in a second direction, opposite the first direction, through the second portion 1008 proximal to the distal segment 1056 and through the first portion 1006 proximal to the distal segment 1054 thereby forming a second gap bridging portion 1046b proximal the first gap bridging portion 1046a. Additional gap bridging portions 1046c and 1046d, for example, can be formed in the same manner across the gap 1010, as illustrated in FIG. 20.

[0119] In certain circumstances, the continuous flexible member 1044 can comprise a suture and can be comprised of a suture material such as polyglycolic acid (PGA) which is marketed under the trade name Vicryl, polylactic acid (PLA or PLLA), polydioxanone (PDS), polyhydroxyalkanoate (PHA), poliglecaprone 25 (PGCL) which is marketed under the trade name Monocryl, polycaprolactone (PCL), and/or a composite of PGA, PLA, PDS, PHA, PGCL and/or PCL, for example. In certain circumstances, the tissue thickness compensator assembly 1042 can be assembled after the first portion 1006 and the second portion 1008 are manufactured, for example, via lyophilization. In some circumstances, a needle (not shown) can be attached to the first end 1048 of the continuous flexible member 1044 and can be passed through the first portion 1006 and the second portion 1008, for example in a zigzag pattern, to couple the first portion 1006 to the second portion 1008, as described above. The first end 1048 and/or the second end 1050 of the continuous flexible member 1044 can be secured to the side walls of the first portion 1006 and/or the second

portion 1008 by tying in one or more knots at the first end 1048 and/or the second end 1050, for example. The knots may abut against the side walls of the first portion 1006 and/or the second portion 1008 to prevent the flexible portion 1052 from unraveling relative to the first portion 1006 and/or the second portion 1008. In other circumstances, the first portion 1006 and the second portion 1008 of the tissue thickness compensator assembly 1042 can be formed around the continuous flexible member 1044. In such circumstances, as illustrated in FIG. 20, the continuous flexible member 1044 can be disposed in a mold 1062, for example in a zigzag pattern, with slots 1064 defined side walls 1066 and slots 1068 defined in central shelf 1070. An organic solution comprising a polymer such as, for example, polylactic acid (PLA) and/or polyglycolic acid (PGA) can be poured into the mold 1062 until the continuous flexible member 1044 is immersed in the organic solution. A mold cover 1072 can be used to ensure that the continuous flexible member 1044 remains immersed in the organic solution which can then be lyophilized using conventional lyophilization techniques and/or any other suitable techniques. The first end 1048 and the second end 1050 of the continuous flexible member 1044 can be secured at openings 1053 and 1055 of the mold 1062, respectively, by tying in one or more knots at the first end 1048 and the second end 1050 after passing the first end 1048 through the opening 1053 and the second end 1050 through the opening 1055, for example. The knots may abut against the side walls of the mold 1062 to prevent the continuous flexible member 1044 from unraveling relative to the mold 1066. After the tissue thickness compensator has been removed from the mold, in various instances, portions of the continuous flexible member 1044, such as portions 1048, 1050, and/or 1052, for example, can then be cut and removed from the tissue thickness compensator. Other techniques for assembling the tissue thickness compensator assembly 1042 are contemplated by the present disclosure.

[0120] In certain circumstances, a tissue thickness compensator assembly such as, for example, the tissue thickness compensator assembly 1042 can be compromised when excessive force or pressure is applied thereto. For instance, pressure can be applied to a tissue thickness compensator assembly such as, for example, the tissue thickness compensator assembly 1042 when the tissue thickness compensator assembly 1042 is loaded onto a staple cartridge such as, for example, the staple cartridge 10000. The tissue thickness compensator assembly 1042 can be equipped with a pressure or force sensitive member that can provide a user with a warning feedback if the pressure experienced by the tissue thickness compensator assembly exceeds a threshold. For example, a pressure or force sensitive film can be attached to the tissue thickness compensator assembly 1042 and can be configured to change color upon experiencing pressure that exceeds the threshold. In certain circumstances, the pressure or force sensitive film can be disposed over the first portion 1006 and/or the second portion 1008 and can be attached thereto via an adhesive, for example. The pressure or force sensitive film can be biocompatible to permit implantation of the pressure or force sensitive film with the tissue thickness compensator assembly 1042 inside a patient.

[0121] Referring now to FIGS. 23-25, a surgical end effector 1100 is illustrated. The end effector 1100 is similar in many respects to various end effectors disclosed elsewhere herein such as, for example, the end effector 22090 (FIG. 9). As illustrated in FIG. 23, the end effector 1100 can include a staple cartridge assembly 1102 which is similar in many respects to the staple cartridge assembly 20200 (FIG. 6), for example. In addition, the end effector 1100 may include a tissue thickness compensator 1104 which is similar in many respects to other tissue thickness compensators

disclose elsewhere in this document such as the tissue thickness compensator 22020 (FIG. 9), the tissue thickness compensator 20220 (FIG. 6), and/or the tissue thickness compensator 10020 (FIG. 4), for example.

[0122] Further to the above, end effector 1100 can include a tissue thickness compensator 1104 wherein the tissue thickness compensator 1104 can be prepared using conventional lyophilization techniques and/or any other suitable techniques. In at least one example, the tissue thickness compensator 1104 can be prepared by dissolving a polymer such as, for example, polylactic acid (PLA) and/or polyglycolic acid (PGA) in an organic solvent and lyophilizing the solution. The tissue thickness compensator 1104 can be comprised of a biocompatible foam which may comprise a porous, open cell foam and/or a porous, closed cell foam, for example.

[0123] Further to the above, the tissue thickness compensator 1104 can be altered or modified for use in a surgical procedure. For example, upon completion of the lyophilization process, the tissue thickness compensator 1104 can be contacted with a modifying member 1106 to modify the tissue thickness compensator 1104 for use in a particular surgical procedure. In certain circumstances, the modification can occur after assembling the tissue thickness compensator 1104 with the end effector 1100, as illustrated in FIGS. 23-35. For example, as illustrated in FIG. 23, the tissue thickness compensator 1104 can be releasably assembled to the cartridge assembly 1102 and modified while assembled with the cartridge assembly 1102. In other circumstances, the modification can occur before assembling the tissue thickness compensator 1104 with the end effector 1100. In at least one example, the modification can be performed as a separate step during manufacturing. In yet another example, the modification may be performed during a surgical procedure.

[0124] As described in greater detail below, the modification process can involve modifying a surface or a plurality of surfaces of the tissue thickness compensator 1104. In certain circumstances, the modification process can involve modifying one or more portions of the tissue thickness compensator 1104. One or more portions can be modified in a single modification process. Alternatively, a plurality of portions can each be modified separately in consecutive modification processes. In certain circumstances, the modification process can comprise a thermal pressing process which can be used to change the shape, size, dimensions, and/or porosity of at least a portion of the tissue thickness compensator 1104. Furthermore, the modification process can include means for creating space within one or more portions of the tissue thickness compensator 1104.

[0125] Referring again to FIGS. 23-25, in certain circumstances, a portion 1107 (FIG. 23) of the tissue thickness compensator 1104 can be modified by a thermal pressing process which may include transitioning the portion 1107 to a glassy state, engaging the portion 1107 with the modifying member 1106, applying pressure onto the portion 1107 while it is in the glassy state, and allowing the portion 1107 to cool below the glassy state while the modifying member 1106 is still engaged with the portion 1107. The modifying member 1106 may be used to maintain the pressure on the portion 1107 for a time period sufficient to create the resulting modified portion 1108 (FIG. 25). It is note worthy that a material's transition into a glassy state can be a reversible transition from a relatively hard state to a relatively molten or flexible state in response to an increase in the temperature of the material to a glass transition temperature. A glass transition temperature of the material can be a particular temperature or, in some instances, a range of temperatures. The tissue thickness compensator modification process described herein takes advantage of this phenomenon by modifying a tissue thickness compensator while the tissue thickness compensator is in the glassy

flexible state and then allowing the tissue thickness compensator to cool below the glass transition temperature while maintaining the modification.

[0126] Further to the above, referring again to FIGS. 23-25, the portion 1107 of the tissue thickness compensator 1104 can be transitioned into the glassy state by heating at least the portion 1107 to a temperature greater than or equal to a glass transition temperature of the material from which the portion 1107 is composed but lower than the melting temperature of the same. For example, the tissue thickness compensator 1104 can be comprised of polyglycolic acid (PGA) and in such circumstances, the portion 1107 can be transitioned into the glassy state by heating the portion 1107 to a temperature that is greater than or equal to the glass transition temperature of polyglycolic acid (PGA) but lower than the melting temperature of the same. In various instances, the glass transition temperature of polyglycolic acid (PGA) can be in the range of 35-40 °C, for example, and its melting temperature can be in the range of 225-230 °C, for example. In at least one example, the portion 1107 of the tissue thickness compensator 1104 can be heated to a temperature that is greater than or equal to 35 °C but lower than 225 °C in order to transition the portion 1107 to the glassy state. In another example, the portion 1107 can be transitioned to the glassy state by heating the portion 1107 to a temperature that is greater than or equal to 40 °C but lower than 200 °C, for example.

[0127] Further to the above, the modifying member 1106 can then be used to apply pressure onto the portion 1107 while the portion 1107 is in the glassy state. The portion 1107 can be allowed to exit the glassy state by cooling the portion 1107 to a temperature below 35 °C, for example. The pressure may be maintained for a time period sufficient to permit the tissue thickness compensator 1104 to retain, or at least partially retain, the modification imposed by the modifying member 1106.

[0128] In certain examples, the pressure can be maintained for a period of time from about 30 seconds to about 8 hours, for example, during the time in the glassy state and/or for a period of time from about 30 seconds to about 8 hours, for example, after exiting the glassy state. In at least one example, the pressure can be maintained for approximately 10 minutes during the time in the glassy state and for approximately 10 minutes after exiting the glassy state. Other time periods for maintaining the pressure are contemplated by the present disclosure.

[0129] In certain circumstances, the modifying member 1106 can be used to apply pressure onto the portion 1107 before the portion 1107 is transitioned to the glassy state. In certain circumstances, the modifying member 1106 may apply pressure to the portion 1107 while the portion 1107 is heated to reach the glassy state, while the portion 1107 is in the glassy state, and/or while the portion 1107 is transitioned or cooled to a temperature below the glassy state. In certain circumstances, the pressure applied to the portion 1107 can be gradually increased toward a threshold as the temperature of the portion 1107 is gradually increased to transition the portion 1107 toward the glassy state, for example. In certain circumstances, the pressure applied to the portion 1107 can be removed, gradually removed, or at least partially reduced as the portion 1107 exits the glassy state, before the portion 1107 exits the glassy state, and/or after the portion 1107 exits the glassy state.

[0130] In certain circumstances, the modifying member 1106 can also be a heat source for transitioning the portion 1107 of the tissue thickness compensator 1104 to the glassy state. For example, the modifying member 1106 can comprise a cylindrical distal portion 1110, as illustrated in FIG. 24, which may include a heating coil (not shown). A user can may energize the heating coil and engage the portion 1107 of the tissue thickness compensator 1104 with the

modifying member 1106 to heat the portion 1107 to a temperature that is greater than or equal the glass transition temperature of the material composition of the portion 1107. Upon reaching a desired temperature, the modifying member may be pressed against the portion 1107, as illustrated in FIG. 24. Alternatively, the modifying member may be pressed against the portion 1107 before the modifying member 1106 reaches the desired temperature. As described above, the pressure may be maintained for a time period sufficient to permit the tissue thickness compensator 1104 to retain, or at least partially retain, the modification imposed by the modifying member 1106. In addition, the heating coil of the modifying member 1106 can be turned off to allow the temperature of the portion 1107 to cool below the glass transition temperature. The modifying member can then be removed. In certain circumstances, the pressure applied by the modifying member 1106 can be initiated prior to the portion 1107 entering the glassy state and maintained throughout the glassy state. In some circumstances, the pressure applied by the modifying member 1106 can be removed while the portion 1107 is in the glassy state.

[0131] As illustrated in FIGS. 23-25, the modifying member 1106 can be configured to change the shape, size, dimensions, density, spring rate, and/or porosity of the portion 1107 of the tissue thickness compensator 1104. For example, the modified portion 1108 may comprise a substantially concave top surface 1114 with a reduced height H1, while the remainder of the tissue thickness compensator 1104 may retain a substantially flat top surface including an original height H which is greater than the reduced height H1, as illustrated in FIG. 25. As described above, the modifying member 1106 may comprise a cylindrical distal portion 1110. In such circumstances, the curvature of the resulting concave surface 1114 can, in part, depend on the curvature of the cylindrical distal portion 1110 of the modifying member 1106 in contact with the portion 1107 of the tissue thickness compensator 1104 during the modification process. Furthermore, the modified portion 1108 may possess a new lower porosity compared to the unmodified portion 1107 which can result, at least in part, from the compressive forces applied to the portion 1107 by the modifying member 1106 during the modification process, as described above. Said another way, the pressure applied to the portion 1107 during the modification process may yield a material redistribution wherein a cross-section through the modified portion 1108 may comprise a greater material density than a similar cross section through the portion 1107 prior to the modification process. Furthermore, the modified portion 1108 may comprise a different spring rate from the remainder of the tissue thickness compensator 1104 which can result, in part, from the changes in density and porosity realized by the modified portion 1108 during the modification process, as described in greater detail below. In at least one instance, the spring rate of the modified portion 1108 may be less than or greater than the spring rate of the unmodified portion 1107.

[0132] Referring now to FIGS. 26-34, a tissue thickness compensator can be modified prior to assembly with an end effector such as, for example, the end effector 22090 (FIG.9). In certain circumstances, as illustrated in FIGS. 27, 30, and 33, a mold can be utilized to modify a tissue thickness compensator using a thermal pressing process, as described above. For example, as illustrated in FIGS. 26-28, a tissue thickness compensator 1120 can be modified to include a longitudinal slot 1122. The tissue thickness compensator 1120 may be similar in many respects to other tissue thickness compensators described elsewhere such as, for example, the tissue thickness compensator 22020 (FIG. 9). For example, like the compensator 22020, the compensator 1120 can be utilized with the end effector 22090. Furthermore, the longitudinal slot 1122 may be similar in many respects to the knife slot 22025. For example, like the

knife slot 22025, the slot 1122 may define a tissue thickness compensator knife path for the cutting portion 10053 between a first stapling portion 1124a and a second stapling portion 1124b. Furthermore, the first stapling portion 1124a and the second stapling portion 1124b can be similar in many respects to the first stapling portion 22021a (FIG. 9) and the second stapling portion 22021b (FIG. 9), respectively, of the tissue thickness compensator 22020. In addition, the slot 1122 can be configured to releasably connect the first stapling portion 1124a and the second stapling portion 1124b such that, in use with the end effector 22090, the cutting portion 10053 can be advanced distally through the slot 1122 to transect the slot 1122 and separate the first stapling portion 1124a and the second stapling portion 1124b.

[0133] Referring again to FIGS. 26-28, the tissue thickness compensator 1120 can be prepared using traditional lyophilization techniques and/or any other suitable techniques. In addition, the tissue thickness compensator 1120 can be modified or altered to create the slot 1122 therethrough. Similar to the tissue thickness compensator 1104, the tissue thickness compensator 1120 can be comprised at least in part of a material comprising a glass transition temperature and can be modified by transitioning the material into a glassy state. In one example, the tissue thickness compensator 1120 can be heated in an oven (not shown) to a temperature greater than or equal to the glass transition temperature of the material composition of the tissue thickness compensator 1120 but less than the melting temperature of the same. A mold 1126 comprising a central beam 1128, as illustrated in FIG. 27, can be utilized to create the slot 1122 by inserting the central beam 1128 into the tissue thickness compensator 1120 while the tissue thickness compensator 1120 is in the glassy state. The tissue thickness compensator 1120 can then be allowed to cool to a temperature below the glass transition temperature while the central beam 1128 remains inserted into the tissue thickness compensator 1120. In some instances, the central beam 1128 can be removed from the tissue thickness compensator 1120 while the tissue thickness compensator 1120 is in its glassy state.

[0134] In certain circumstances, a cooling medium can be utilized to actively cool the tissue thickness compensator 1120. In some instances, a fan can be used to generate a flow of air over the tissue thickness compensator 1120 while the tissue thickness compensator 1120 is in the mold 1126 and/or after the tissue thickness compensator 1120 has been removed from the mold. In some instances, a refrigeration process can be utilized to cool the tissue thickness compensator 1120 while the tissue thickness compensator 1120 is in the mold 1126 and/or after the tissue thickness compensator 1120 has been removed from the mold. The central beam 1128 can be removed after transitioning the tissue thickness compensator 1120 out of the glassy state. The central beam 1128 can remain inserted into the tissue thickness compensator 1120 for a time period sufficient to permit the tissue thickness compensator 1120 to retain, or at least substantially retain, the space occupied by the central beam 1128. In certain examples, the central beam 1128 can remain inserted for a period of time from about 30 seconds to about 8 hours, for example, during the time in the glassy state and/or for a period of time from about 30 seconds to about 8 hours, for example, after exiting the glassy state. In at least one example, the central beam 1128 can remain inserted for approximately 10 minutes during the time in the glassy state and for approximately 10 minutes after exiting the glassy state. Other time periods for maintaining the central beam 1128 within the tissue thickness compensator 1120 are contemplated by the present disclosure.

[0135] Further to the above, as illustrated in FIG. 28, pressure applied by the central beam 1128 during the modification process may yield an increased material density at a portion 1130 of the tissue thickness compensator

1120. The portion 1130 may connect the first stapling portion 1124a and a second stapling portion 1124b thereby providing additional stability for the slot 1122. In certain circumstances, the mold 1126 may comprise edge modifiers such as, for example, edge modifiers 1132a and 1132b which can modify the tissue thickness compensator 1120 during the modification process to produce modified edges 1134a and 1134b, respectively, as illustrated in FIG. 28.

[0136] Referring again to FIGS. 26-28, it may be desirable to remove a significant amount of material from the tissue thickness compensator 1120 to create the slot 1122. In such circumstances, the central beam 1128 can be heated to a temperature greater than the melting temperature of the material composition of the tissue thickness compensator 1120. Upon inserting the heated central beam 1128 into the tissue thickness compensator 1120, the central beam 1128 may melt through the tissue thickness compensator 1120 thereby creating a space for the slot 1122 within the tissue thickness compensator 1120, as illustrated in FIG. 28. In certain circumstances, it may be desirable to gradually increase the pressure applied by the central beam 1128 against the tissue thickness compensator 1120 to gradually insert the central beam 1128 into the tissue thickness compensator 1120.

[0137] In certain circumstances, it can be desirable to increase material density of one or more surfaces of a tissue thickness compensator. As illustrated in FIGS. 29-31, a tissue thickness compensator 1140 can be modified or altered such that a surface 1142 of the tissue thickness compensator 1140 may comprise a higher material density than the remainder of the tissue thickness compensator 1140, which can be achieved, in certain circumstances, post lyophilization. The tissue thickness compensator 1140 may be similar in many respects to other tissue thickness compensators described elsewhere such as, for example, the tissue thickness compensator 22020 (FIG. 9) and/or the tissue thickness compensator 1120 (FIG. 26). A surface modifier 1144 can be utilized to modify the surface 1142 of the tissue thickness compensator 1140 using a thermal pressing process which is similar in many respects to the thermal pressing processes used to modify the tissue thickness compensator 1104 and/or the tissue thickness compensator 1120, as described above. For example, the tissue thickness compensator 1140 can be comprised at least in part of a material comprising a glass transition temperature and can be modified after being transitioned into a glassy state.

[0138] As described above, a tissue thickness compensator such as, for example, the tissue thickness compensator 1140 can be transitioned to the glassy state where it is heated to a temperature greater than or equal to the glass transition temperature of the material composition of the tissue thickness compensator 1140 but less than the melting temperature of the same. The surface modifier 1144 can be pressed against the surface 1142 while the tissue thickness compensator 1140 is in the glassy state. The pressure applied by the surface modifier 1144 may compress the surface 1142 thereby increasing the material density of the surface 1142. The increase in material density can be retained by the surface 1142 by allowing the surface 1142 to cool to a temperature below the glass transition temperature.

[0139] In certain instances, the pressure applied by the surface modifier 1144 against the surface 1142 can be maintained for a period of time from about 30 seconds to about 8 hours, for example, during the time in the glassy state and/or for a period of time from about 30 seconds to about 8 hours, for example, after exiting the glassy state. In at least one example, the pressure can be maintained for approximately 10 minutes during the time in the glassy state and for approximately 10 minutes after exiting the glassy state. Other time periods for maintaining the pressure applied by the surface modifier 1144 against the surface 1142 are contemplated by the present disclosure.

[0140] In some instances, a fan can be used to generate a flow of air over the tissue thickness compensator 1140 while the tissue thickness compensator 1140 is in contact with the modifier 1144 and/or after the tissue thickness compensator 1140 has been removed from the modifier 1144. In some instances, a refrigeration process can be utilized to cool the tissue thickness compensator 1140 while the tissue thickness compensator 1140 is in contact with the modifier 1144 and/or after the tissue thickness compensator 1140 has been removed from the modifier 1144. Upon transitioning the tissue thickness compensator 1140 out of the glassy state, in various instances, the surface modifier 1144 can be disengaged from the tissue thickness compensator 1140. In certain circumstances, the surface modifier 1144 can include a heating element which can be utilized to increase the temperature of the surface 1142 to a temperature greater than or equal to the glass transition temperature of the material composition of the tissue thickness compensator 1140, as described above.

[0141] Referring again to FIG. 30, the surface modifier 1144 may comprise a flat, or at least substantially flat, contacting surface 1146 for contacting the surface 1142, for example. In other circumstances, the contacting surface 1146 may comprise various textures such as, for example, protrusions which can extend into the surface 1142 of the tissue thickness compensator 1140 during the modification process. In certain circumstances, the surface modifier 1144 can be used to apply pressure onto the surface 1142 of the tissue thickness compensator 1140 before the tissue thickness compensator 1140 is transitioned to the glassy state. In certain circumstances, the surface modifier 1144 may apply pressure to the surface 1142 while the tissue thickness compensator 1140 is heated to reach the glassy state, while the tissue thickness compensator 1140 is in the glassy state, and/or while the tissue thickness compensator 1140 is transitioned or cooled to a temperature below the glassy state. In certain circumstances, the pressure applied by the surface modifier 1144 to the surface 1142 can be gradually increased toward a threshold as the temperature of the tissue thickness compensator 1140 is gradually increased to transition the tissue thickness compensator 1140 toward the glassy state, for example. In certain circumstances, the pressure applied to the surface 1142 can be removed, gradually removed, or at least partially reduced as the tissue thickness compensator 1140 exits the glassy state, before the tissue thickness compensator 1140 exits the glassy state, and/or after the tissue thickness compensator 1140 exits the glassy state.

[0142] In certain circumstances, the tissue thickness compensator 1140 can be modified or altered to include a skin or a dense outer layer. In certain circumstances, the resulting skin or dense outer layer may comprise textures such as, for example, protrusions which can extend into the surface 1142 of the tissue thickness compensator 1140. In certain instances, the contacting surface 1146 of the surface modifier 1144 can be heated to a temperature greater than or equal to the melting temperature of the material composition of the tissue thickness compensator 1140. The surface modifier 1144 and/or the tissue thickness compensator 1140 can be moved to bring the surface 1142 of the tissue thickness compensator 1140 into contact with the heated contacting surface 1146 of the surface modifier 1144 thereby melting, or at least substantially melting, the surface 1142. The surface modifier 1144 and the tissue thickness compensator 1140 can then be separated to permit the modified surface 1142 to cool below its melting temperature which may create a skin or a dense outer layer onto the tissue thickness compensator 1140.

[0143] In certain instances, the contacting surface 1146 of the surface modifier 1144 can be heated prior to coming in contact with the surface 1142. In other instances, the contacting surface 1146 of the surface modifier 1144 can be heated after coming in contact with the surface 1142.

[0144] In certain instances, the contacting surface 1146 of the surface modifier 1144 can remain in contact with the surface 1142 of the tissue thickness compensator 1140 for a time period sufficient to allow the surface 1142 to flow into a desired geometry. Such a time period can range from about 30 seconds to about 8 hours, for example; other time periods are contemplated by the present disclosure. Such a time period can be sufficient to locally affect and/or melt the material of the tissue thickness compensator 1140 and have it flow into a new geometry. As described herein, such a new geometry can be prescribed by the tooling used to make the tissue thickness compensator 1140.

[0145] In certain instances, the surface 1142 of the tissue thickness compensator 1140 can be allowed to cool, or can be actively cooled, to a temperature below the melting temperature of the tissue thickness compensator 1140 before separating the surface modifier 1144 from the tissue thickness compensator 1140. In other instances, the surface 1142 of the tissue thickness compensator 1140 can be allowed to cool, or can be actively cooled, to a temperature below the melting temperature of the tissue thickness compensator 1140 after separating the surface modifier 1144 from the tissue thickness compensator 1140.

[0146] Further to the above, the modified surface 1142 can comprise a density which is approximately 10% greater than the density of the remainder of the tissue thickness compensator 1140, approximately 20% greater than the density of the remainder of the tissue thickness compensator 1140, approximately 30% greater than the density of the remainder of the tissue thickness compensator 1140, approximately 40% greater than the density of the remainder of the tissue thickness compensator 1140, approximately 50% greater than the density of the remainder of the tissue thickness compensator 1140, approximately 60% greater than the density of the remainder of the tissue thickness compensator 1140, approximately 70% greater than the density of the remainder of the tissue thickness compensator 1140, approximately 80% greater than the density of the remainder of the tissue thickness compensator 1140, approximately 90% greater than the density of the remainder of the tissue thickness compensator 1140, and/or approximately 100% greater than the density of the remainder of the tissue thickness compensator 1140, for example. In various circumstances, the modified surface 1142 can comprise a density which is more than the density of the remainder of the tissue thickness compensator 1140 and less than twice the density of the remainder of the tissue thickness compensator 1140, for example. In various circumstances, the modified surface 1142 can comprise a density which is over twice the density of the remainder of the tissue thickness compensator 1140, for example.

[0147] Referring now to FIGS. 32-34, a tissue thickness compensator 1150 can be modified to include a plurality of apertures 1152 which may extend at least partially through the tissue thickness compensator 1150. The tissue thickness compensator 1150 may be similar in many respects to other tissue thickness compensators described herein such as, for example, the tissue thickness compensator 20220 (FIG. 6). Like the compensator 20220, the compensator 1150 can be utilized with the cartridge assembly 20200 (FIG. 6) and the apertures 1152 may be similar in many respects to the clearance apertures 20224 extending at least partially through the tissue thickness compensator 20220. For example, like the apertures 20224, the apertures 1152 can be aligned with corresponding staple legs 20232 (FIG. 7) when the tissue thickness compensator 1150 is assembled with the cartridge assembly 20200 such that the staple

legs 20232 may move through the clearance apertures 1152 in the tissue thickness compensator 1150 when the staple legs 20232 move from the unfired configuration to the fired configuration, as described above in greater detail.

[0148] Further to the above, referring again to FIGS. 32-34, the tissue thickness compensator 1150 can be prepared using traditional lyophilization techniques and/or any other suitable techniques. In certain circumstances, a polymer having a glass transition temperature such as, for example, polylactic acid (PLA) and/or polyglycolic acid (PGA) can be dissolved in an organic solvent to form a solution which can be lyophilized to produce the tissue thickness compensator 1150. Furthermore, the tissue thickness compensator 1150 can be modified post lyophilization using a thermal pressing process which is similar in many respects to the thermal pressing processes used to modify the tissue thickness compensator 1104, the tissue thickness compensator 1120, and/or the tissue thickness compensator 1140, for example, as described above. For example, the tissue thickness compensator 1150 can be modified to include the apertures 1152 once the tissue thickness compensator 1150 is transitioned to a glassy state.

[0149] As described above, a tissue thickness compensator such as, for example, the tissue thickness compensator 1150 can be transitioned to a glassy state by being heated in an oven (not shown) to a temperature greater than or equal to the glass transition temperature of the material composition of the tissue thickness compensator 1150 but less than the melting temperature of the same. A mold 1154 comprising a plurality of posts, dowels, pins, and/or protrusions, for example, such as, for example, needles 1156 can be utilized to create the apertures 1152 by inserting the needles 1156 into the tissue thickness compensator 1150 while the tissue thickness compensator 1150 is in the glassy state. The tissue thickness compensator 1150 can then be allowed to cool to a temperature below the glass transition temperature while the needles 1156 remain inserted into the tissue thickness compensator 1150. In some instances, the needles 1156 can be removed from the tissue thickness compensator 1150 while the tissue thickness compensator 1150 is in the glassy state. In some instances, a fan can be used to generate a flow of air over the tissue thickness compensator 1150 while the tissue thickness compensator 1150 is engaged with the needles 1156 and/or after the tissue thickness compensator 1150 has been disengaged from the needles 1156. In some instances, a refrigeration process can be utilized to cool the tissue thickness compensator 1150 while the tissue thickness compensator 1150 is engaged with the needles 1156 and/or after the tissue thickness compensator 1150 has been disengaged from the needles 1156. In various instances, the needles 1156 can be removed after transitioning the tissue thickness compensator 1150 out of the glassy state. The needles 1156 can remain inserted into the tissue thickness compensator 1150 for a time period sufficient to permit the tissue thickness compensator 1150 to retain, or at least substantially retain, the spaces defining the apertures 1152 which are occupied by the needles 1156.

[0150] In certain examples, the needles 1156 can remain inserted for a period of time from about 30 seconds to about 8 hours, for example, during the time in the glassy state and/or for a period of time from about 30 seconds to about 8 hours, for example, after exiting the glassy state. In at least one example, the needles 1156 can remain inserted for approximately 10 minutes during the time in the glassy state and for approximately 10 minutes after exiting the glassy state. Other time periods for maintaining the needles 1156 inserted into the tissue thickness compensator 1150 are contemplated by the present disclosure.

[0151] In certain circumstances, the needles 1156 can be removed from the tissue thickness compensator 1150 prior to transitioning the tissue thickness compensator 1150 out of the glassy state. In other circumstances, the needles 1156

can be gradually removed over time. For example, the needles 1156 can be partially removed from the tissue thickness compensator 1150 prior to transitioning the tissue thickness compensator 1150 out of the glassy state. The needles 1156 can then be fully removed from the tissue thickness compensator 1150 after transitioning the tissue thickness compensator 1150 out of the glassy state. The reader will appreciate that the greater the depth of insertion of the needles 1156 into the tissue thickness compensator 1150, the greater the depth of the corresponding apertures 1152 that can be created in the tissue thickness compensator 1150.

[0152] Referring again to FIGS. 32-34, in certain instances, the needles 1156 can be heated to a temperature greater than or equal to the melting temperature of the material composition of the tissue thickness compensator 1150. In addition, the needles 1156 can be inserted into the tissue thickness compensator 1150 to create the apertures 1152 by melting, or at least partially melting, through the regions of the tissue thickness compensator 1150 that receive the needles 1156. In various instances, the needles 1156 can be heated prior to their insertion into the tissue thickness compensator 1150. In various instances, the needles 1156 can be heated after their insertion into the tissue thickness compensator 1150. In various instances, the needles 1156 can be gradually heated as the needles 1156 are inserted into the tissue thickness compensator 1150.

[0153] In certain instances, the needles 1156 may remain positioned within the tissue thickness compensator 1150 for a period of time sufficient to permit the melted material of the tissue thickness compensator 1150 to flow into a desired geometry. Such a time period can range from about 30 seconds to about 8 hours, for example; other time periods are contemplated by the present disclosure. Such a time period can be sufficient to locally affect and/or melt the material of the tissue thickness compensator 1150 and have it flow into a new geometry. As described herein, such a new geometry can be prescribed by the tooling used to make the tissue thickness compensator 1150.

[0154] In certain instances, the tissue thickness compensator 1150 can be allowed to cool, or can be actively cooled, to a temperature below the melting temperature of the tissue thickness compensator 1150 before separating the needles 1156 from the tissue thickness compensator 1150. In other instances, the tissue thickness compensator 1150 can be allowed to cool, or can be actively cooled, to a temperature below the melting temperature of the tissue thickness compensator 1150 after separating the needles 1156 from the tissue thickness compensator 1150.

[0155] Referring again to FIGS. 32-34, the needles 1156 can be arranged in rows extending longitudinally along a length of the mold 1154 which may correspond to staple rows in a staple cartridge such as, for example, the staple cartridge assembly 20200 (FIG. 6). For example, as illustrated in FIG. 33, the needles 1156 can be arranged in six rows which can be configured to create six rows of the apertures 1152 that can be configured to receive six rows of the staples 20230 (FIG. 7). In certain circumstances, as illustrated in FIG. 33, the rows of the needles 1156 can be arranged in two groups which are spaced apart and configured to be received in two portions 1158 and 1160 of the tissue thickness compensator 1150 thereby creating two groups of the apertures 1152 separated by an intermediate portion 1162. The intermediate portion 1162 can be positioned, at least partially, over the cartridge knife slot 22015 (FIG. 6), when the tissue thickness compensator 1150 is assembled with staple cartridge assembly 20200. In use, the firing member 10052 (FIG. 10) can be advanced distally to push the staple legs 20232 (FIG. 8) through the apertures 1152 within the portions 1158 and 1160 and advance the cutting portion 10053 (FIG. 10) to transect the intermediate portion 1162 and separate the portions 1158 and 1160.

[0156] Referring again to FIGS. 32-34, the apertures 1152 can be configured to extend within the tissue thickness compensator 1150 and terminate at a certain depth within the tissue thickness compensator 1150. The apertures 1152 may comprise uniform depths, as illustrated in FIG. 34. In other circumstances, the apertures 1152 may comprise different depths (not shown). For example, a first row of the apertures 1152 may comprise a first depth and a second row of the apertures 1152 may comprise a second depth different from the first depth and yet a third row of the apertures 1152 may comprise a third depth different from the first depth and the second depth. The depths of the apertures 1152 can be determined, at least in part, by the heights of the corresponding needles 1156. For example, a first row of the needles 1156 comprising a first height and a second row of the needles 1156 comprising second height greater than first height may create a first row of the apertures 1152 comprising a first depth and a second row of the apertures 1152 comprising a second depth which is greater than the first depth.

[0157] Referring again to FIGS. 32-34, the needles 1156 can be configured to define a trajectory for the apertures 1152 within the tissue thickness compensator 1150. In certain circumstances, the needles 1156 can extend along an axis that is perpendicular and/or substantially perpendicular to a mold surface 1164 of the mold 1154, as illustrated in FIG. 33. Inserting the needles 1156 into the tissue thickness compensator 1150 while maintaining a parallel relationship between the mold surface 1164 and a surface 1166 of the tissue thickness compensator 1150 may result in defining a perpendicular and/or substantially perpendicular trajectory for the apertures 1152 relative to the surface 1166 of the tissue thickness compensator 1150, as illustrated in FIG. 34. In other circumstances, the needles 1156 can extend from the mold surface 1164 at an oblique angle (not shown) and/or the insertion trajectory of the needles 1156 into the tissue thickness compensator 1150 can be at an angle such that the needles 1156 may define a non-perpendicular trajectory for the apertures 1152 relative to the surface 1166 of the tissue thickness compensator 1150. In certain circumstances, a group of the needles 1156 can be parallel and/or substantially parallel to each other, as illustrated in FIG. 33, resulting in a group of the apertures 1152 that may be parallel and/or substantially parallel to each other, as illustrated in FIG. 24. In other circumstances, although not illustrated, a group of non-parallel needles can extend from the mold surface 1164 and may result in non-parallel apertures when inserted into the tissue thickness compensator 1150. In some circumstances, the needles 1156 can be configured to create apertures within the tissue thickness compensator 1150 that can comprise a partially curved trajectory and/or a partially linear trajectory. For example, the needles 1156 can extend from the mold surface 1164 in a partially curved trajectory and can be inserted into the tissue thickness compensator 1150 to create apertures within the tissue thickness compensator 1150 with a corresponding partially curved trajectory.

[0158] Referring again to FIGS. 32-34, some or all of the needles 1156 can comprise blunt distal ends 1168, as illustrated in FIG. 33. In other circumstances, some or all of the needles 1156 can comprise sharp distal ends (not shown). Some or all of the needles 1156 can comprise cylindrical, or at least substantially cylindrical, shapes, for example, as illustrated in FIG. 33. Other shapes are also contemplated by the present disclosure. **[0159]** In various instances, one or more of the needles 1156 extending from the mold surface 1164 may not be insertable through the full thickness of the tissue thickness compensator 1150. In certain instances, one or more of the needles 1156 extending from the mold surface 1164 can be insertable through the full thickness of the tissue thickness compensator 1150 to create openings an/or holes that extend through the full thickness of the tissue thickness compensator 1150. In

certain instances, one or more of the needles 1156 extending from the mold surface 1164 can be inserted through a first side of the tissue thickness compensator 1150 and exited through a second side of the tissue thickness compensator 1150 which may be opposite the first side, for example. In certain instances, one or more of the needles 1156 may comprise a length greater than the full thickness of the tissue thickness compensator 1150 to facilitate the insertion of the one or more needles 1156 through the full thickness of the tissue thickness compensator 1150.

[0160] Referring now to FIGS. 35-37, it may be desirable to resize a tissue thickness compensator. For example, one or more dimensions of a tissue thickness compensator may be adjusted to correspond to dimensions of a staple cartridge in order to provide a better fit to the staple cartridge when the tissue thickness compensator is assembled with the staple cartridge. In certain circumstances, a tissue thickness compensator 1170 can be resized by changing its height from a first height H1, as illustrated in FIG. 35, to a second height H2, as illustrated in FIG. 36. The tissue thickness compensator 1170 may be similar in many respects to other tissue thickness compensators described herein such as, for example, the tissue thickness compensator 22020 (FIG. 9), the tissue thickness compensator 1140 (FIG. 29), and/or the tissue thickness compensator 1150 (FIG. 32). For example, like the compensator 22020, the compensator 1170 can be utilized with the end effector 22090 (FIG. 9).

[0161] In various instances, referring again to FIGS. 35-37, the tissue thickness compensator 1170 can be prepared using traditional lyophilization techniques and/or any other suitable techniques. In certain instances, the tissue thickness compensator 1170 can be resized, as illustrated in FIG. 37, using a thermal pressing process and a mold 1172, for example. The mold 1172 may comprise a receiver 1174 configured to receive the tissue thickness compensator 1170 and an adjustment member 1176 which can be partially insertable into the receiver 1174. The tissue thickness compensator 1170 can be resized when the tissue thickness compensator 1170 is transitioned into a glassy state. In one embodiment, the tissue thickness compensator 1170 can be heated in an oven (not shown) to a temperature greater than or equal to a glass transition temperature of the material composition of the tissue thickness compensator 1170 but less than the melting temperature of the same. In another embodiment, the receiver 1174 and/or the adjustment member 1176 may comprise a heating element for transitioning the tissue thickness compensator 1170 to the glassy state. The adjustment member 1176 can then be inserted into the receiver 1174 a distance H3, for example, as illustrated in FIG. 37, thereby compressing the tissue thickness compensator 1170 and reducing its height from the first height H1 to the second height H2. In some instances, the adjustment member 1176 can be inserted into the receiver 1174 before the tissue thickness compensator 1170 enters into the glassy state or just as the tissue thickness compensator 1170 enters into the glassy state. The adjustment member 1176 can be held against the tissue thickness compensator 1170 to compress the tissue thickness compensator 1170 for a time period sufficient to permit the tissue thickness compensator 1170 to retain, or at least substantially retain, the second height H2, as illustrated in FIG. 36. The tissue thickness compensator 1170 can then be allowed to cool to a temperature below the glass transition temperature while under compression from the adjustment member 1176. After transitioning the tissue thickness compensator 1170 out of the glassy state, the adjustment member 1176 can be retracted. In some instances, the adjustment member 1176 can be retracted before the tissue thickness compensator 1170 exits the glassy state. In certain circumstances, the above described resizing process can be utilized to change another dimension of the tissue

thickness compensator 1170 such as a length or a width of the tissue thickness compensator 1170, for example. In some circumstances, these dimensions can be modified simultaneously or modified sequentially.

[0162] In certain examples, the compression from the adjustment member 1176 can be maintained for a period of time from about 30 seconds to about 8 hours, for example, during the time in the glassy state and/or for a period of time from about 30 seconds to about 8 hours, for example, after exiting the glassy state. In at least one example, the compression from the adjustment member 1176 can be maintained for approximately 10 minutes during the time in the glassy state and for approximately 10 minutes after exiting the glassy state. Other time periods for maintaining the compression imposed by the adjustment member 1176 against the tissue thickness compensator 1170 are contemplated by the present disclosure.

[0163] In certain circumstances, the adjustment member 1176 can be used to apply pressure onto the tissue thickness compensator 1170 before the tissue thickness compensator 1170 is transitioned to the glassy state. In certain circumstances, the adjustment member 1176 may apply pressure to the tissue thickness compensator 1170 while the tissue thickness compensator 1170 is heated to reach the glassy state, while the tissue thickness compensator 1170 is in the glassy state, and/or while the tissue thickness compensator 1170 is transitioned or cooled to a temperature below the glassy state. In certain circumstances, the pressure applied to the tissue thickness compensator 1170 can be gradually increased toward a threshold as the temperature of the tissue thickness compensator 1170 is gradually transitioned toward the glassy state, for example. In certain circumstances, the pressure applied to the tissue thickness compensator 1170 can be removed, gradually removed, or at least partially reduced as the tissue thickness compensator 1170 exits the glassy state, before the tissue thickness compensator 1170 exits the glassy state, and/or after the tissue thickness compensator 1170 exits the glassy state.

[0164] The reader will appreciate that the different molds utilized in the modification processes described above such as, for example, the molds 1144, 1154, and/or 1172 are illustrative examples. Other mold designs and configurations can also be employed to manipulate tissue thickness compensators in a variety of ways. Furthermore, the forces involved in manipulating a tissue thickness compensator need not only be compressive forces. For example, tensile forces can also be utilized to modify, reshape, and/or resize a tissue thickness compensator in similar manners to those described above. For example, the tissue thickness compensator 1170 can be stretched using tensile forces to reduce its height from the first height H1 (FIG. 35) to the second height H2 (FIG. 36), for example, using a modification process that is similar in many respects to the modification processes described above. In certain circumstances, combinations of tensile and compressive forces can be used to manipulate a tissue thickness compensator during a modification process.

[0165] Referring again to FIGS. 35-37, it may be desirable to modify the porosity of a tissue thickness compensator for use in a surgical procedure. A tissue thickness compensator may comprise a porous, open cell foam and/or a porous, closed cell foam, for example. Traditional lyophilization techniques may provide some control over a tissue thickness compensator's porosity but such control may not be easily reproducible and may need additional fine adjustments that may not be obtainable by traditional lyophilization techniques. As illustrated in FIGS. 35-37, the height of the tissue thickness compensator 1170 can be changed from the first height H1 (FIG. 35) to the second height H2 (FIG. 36), for example, using the modification process described above. In addition, porosity of the tissue

thickness compensator 1170 can also be modified using the same and/or a similar modification process. For example, the tissue thickness compensator 1170 may comprise a first porosity (FIG. 35) prior to the modification process and a second porosity (FIG. 36) after completion of the modification process, as described above. The change in porosity can be attributed, at least in part, to the compressive forces and/or the energy applied to the tissue thickness compensator 1170 by the adjustment member 1176 during the modification process described above.

[0166] Further to the above, the tissue thickness compensator 1170 may comprise a plurality of pores 1180. Some or all of the pores 1180 may be altered in position, size, and/or shape, for example, as a result of the modification process described above. For example, one or more of the pores 1180 may comprise a spherical, or substantially spherical, shape prior to the modification process which may be altered to an oval, or substantially oval, shape as a result of the modification process. In at least one example, one or more of the pores 1180 may comprise a first size prior to the modification process and a second size different from the first size as a result of the modification process. In certain circumstances, as described below in greater detail, the porosity changes can be localized to one or more regions or zones of the tissue thickness compensator 1170.

[0167] Furthermore, in certain circumstances, the change in porosity of the tissue thickness compensator 1170 may be accompanied by a change in density of the tissue thickness compensator 1170. In other words, as the adjustment member 1176 is advanced against the tissue thickness compensator 1170, compressive forces may reduce space occupied by the tissue thickness compensator 1170 thereby causing material and/or pore redistribution which may yield an increase in the density of the tissue thickness compensator 1170 and/or a reduction in its porosity. In certain circumstances, as described below in greater detail, the density changes can be localized to one or more regions or zones of the tissue thickness compensator 1170.

[0168] Further to the above, the change in porosity and/or density of the tissue thickness compensator 1170 may yield a change in the spring rate of the tissue thickness compensator 1170. A tissue thickness compensator's spring rate can influence its ability to compensate for tissue thickness when the tissue thickness compensator is deployed against tissue captured by staples such as, for example, the staples 20230 (FIG. 8), as described above in greater detail. Furthermore, a tissue thickness compensator's spring rate can also influence its ability to apply pressure against tissue captured with the tissue thickness compensator by a staple. In other words, a change in a tissue thickness compensator's spring rate may change the pressure exerted by the tissue thickness compensator against tissue captured by a staple. Since different tissue types may respond more positively to certain pressures, fine control over a tissue thickness compensator's spring rate can be advantageous.

[0169] As illustrated in FIGS. 35-37, the tissue thickness compensator 1170 may comprise a first spring rate (FIG. 35) which may be altered or modified to a second spring rate (FIG. 36) different from the first spring rate using the modification process described above. For example, as described above, the adjustment member 1176 can be advanced against the tissue thickness compensator 1170 while the tissue thickness compensator 1170 is in the glassy state. In response, the tissue thickness compensator 1170 may be compressed which may cause a change in the spring rate of the tissue thickness compensator 1170. The adjustment member 1176 can be retained in the advanced position for a period of time sufficient to permit the tissue thickness compensator 1170 to retain, or at least substantially retain, the change in spring rate. In addition, the tissue thickness compensator 1170 can be allowed to cool below the glass

transition temperature of its material composition while maintaining the pressure applied by the adjustment member 1176 against the tissue thickness compensator 1170.

[0170] In certain instances, the adjustment member 1176 can be maintained in the advanced position against the tissue thickness compensator 1170 for a period of time from about 30 seconds to about 8 hours, for example, during the time in the glassy state and/or for a period of time from about 30 seconds to about 8 hours, for example, after exiting the glassy state. In at least one example, the adjustment member 1176 can be maintained in the advanced position against the tissue thickness compensator 1170 for approximately 10 minutes during the time in the glassy state and for approximately 10 minutes after exiting the glassy state. Other time periods for maintaining the adjustment member 1176 in the advanced position against the tissue thickness compensator 1170 are contemplated by the present disclosure.

[0171] In certain circumstances, the adjustment member 1176 can be used to apply pressure onto the tissue thickness compensator 1170 to change the spring rate of the tissue thickness compensator 1170 before the tissue thickness compensator 1170 is transitioned to the glassy state. In certain circumstances, the adjustment member 1176 may apply pressure to the tissue thickness compensator 1170 while the tissue thickness compensator 1170 is heated to reach the glassy state, while the tissue thickness compensator 1170 is in the glassy state, and/or while the tissue thickness compensator 1170 is transitioned or cooled to a temperature below the glassy state. In certain circumstances, the pressure applied to the tissue thickness compensator 1170 can be gradually increased toward a threshold as the temperature of the tissue thickness compensator 1170 is gradually increased to transition the tissue thickness compensator 1170 toward the glassy state, for example. In certain circumstances, the pressure applied to the tissue thickness compensator 1170 can be removed, gradually removed, or at least partially reduced as the tissue thickness compensator 1170 exits the glassy state, before the tissue thickness compensator 1170 exits the glassy state, and/or after the tissue thickness compensator 1170 exits the glassy state.

[0172] Referring again to FIGS. 35-40, the tissue thickness compensator 1170 may be manufactured with a native spring rate using traditional lyophilization techniques and/or any other suitable techniques. As described above, the spring rate of the tissue thickness compensator 1170 can influence its ability to apply pressure against tissue captured with the tissue thickness compensator 1170 by a staple. The modification process described above may be utilized to adjust the native spring rate of the tissue thickness compensator 1170 to adjust its ability to apply pressure against tissue captured with the tissue thickness compensator 1170 by the staple. In certain circumstances, the native spring rate of the tissue thickness compensator 1170 can be increased from a first spring rate at point A (FIG. 40) to a second spring rate including and up to a maximum spring rate at point B (FIG. 40). In certain circumstances, such increase of the spring rate of the tissue thickness compensator 1170 can be achieved by applying compression forces to the tissue thickness compensator 1170 using the adjustment member 1176 while the tissue thickness compensator 1170 is in the glassy state, as explain in the modification process described above. As illustrated in FIG. 40, the point B represents a maximum elastic yield of the tissue thickness compensator 1170. As such, any additional compression applied by the adjustment member 1176 to the tissue thickness compensator 1170 beyond a threshold compression at the point B may produce a decrease in the spring rate of the modified tissue thickness compensator 1170. For example, as illustrated in FIG. 40, the spring rate at the point C is lower than the spring rate at the point B even though the

compression force applied by the adjustment member 1176 to the tissue thickness compensator 1170 at point C is greater than the compression force applied at the point B.

[0173] As discussed above, one or more processes can be used to affect the spring rate, and/or any other property, of a material used in conjunction with a fastener cartridge and/or a surgical fastening instrument, for example. The spring rate, and/or any other property, of the material may change throughout the modification process or processes. Such a change may be gradual in some circumstances, while in other circumstances, the change may be sudden. In various instances, one or more of the steps of the modification process may cause an increase in the spring rate of the material while one or more steps may cause a decrease in the spring rate of the material. Ultimately, the net change in the spring rate can be measured as a comparison between an original spring rate before the modification process begins and a subsequent spring rate after the modification process has been completed. In various instances, a material may comprise an altered spring rate after the material has been heated and then cooled.

[0174] In certain circumstances, it may be desirable to apply one or more of the above described modification processes to a tissue thickness compensator. For example, a first modification process can be utilized to modify porosity of the tissue thickness compensator, as described above with respect to the tissue thickness compensator 1170. A second modification process, following the first modification process, can be utilized to alter a surface of the tissue thickness compensator, as described above with respect to the tissue thickness compensator 1140. Furthermore, a third modification process can be utilized to modify the tissue thickness compensator to include a longitudinal slot similar to the longitudinal slot 1122 of the tissue thickness compensator 1120. In yet a fourth modification process, the tissue thickness compensator can be modified to include apertures similar to the apertures 1152 of the tissue thickness compensator 1150. The reader will appreciate that some of above mentioned modifications can be combined or grouped in a single modification process. For example, a mold can be designed to include the needles 1156 of the mold 1154 and the central beam 1128 of the mold 1126. Other modification arrangements are contemplated by the present disclosure.

[0175] Referring now to FIGS. 38 and 39, a tissue thickness compensator such as, for example, tissue thickness compensator 1190 can be altered or modified using one or more of the modification processes described above to include portions with different spring rates, porosities, and/or densities. In certain circumstances, the tissue thickness compensator 1190 can be modified using one or more of the modification processes described above to include a gradient pore morphology (i.e. small pores gradually increasing in size to large pores across the thickness of the tissue thickness compensator 1190 in one direction). Such morphology could be more optimal for tissue in-growth or hemostatic behavior. Further, the gradient could also be compositional with a varying bio-absorption profile. A short term absorption profile may be preferred to address hemostasis while a long term absorption profile may address better tissue healing without leakages.

[0176] Referring again to FIGS. 38 and 39, the tissue thickness compensator 1190 may include one or more zone geometries that are different from the remainder of the tissue thickness compensator 1196. For example, as illustrated in FIG. 38, the tissue thickness compensator 1190 may include one or more protruding portions such as, for example, protruding portion 1196. In addition, the tissue thickness compensator 1190 may comprise a uniform, or at least a substantially uniform, first spring rate, first porosity, and/or first density through the tissue thickness compensator

1190 including the one or more zone geometries, as illustrated in FIG. 38. In certain circumstances, the tissue thickness compensator 1190 can be altered or modified using one or more of the modification processes described above to alter or modify the one or more zone geometries and/or to induce localized changes in the first spring rate, the first porosity, and/or the first density, for example. The modified tissue thickness compensator 1190 may comprise one or more modified zones with different spring rates, porosities, and/or densities from other modified zones and/or the first spring rate, the first porosity, and/or the first density, respectively, of the remainder of the tissue thickness compensator 1190. In certain circumstances, the resulting one or more modified zones may correspond to the one or more zone geometries. For example, as illustrated in FIG. 39, the tissue thickness compensator 1190 may be altered or modified to level, or at least substantially level, the protruding portion 1196 and to form a flat, or at least a substantially flat, surface 1198, for example. The modified tissue thickness compensator 1190 may include a first portion 1192 comprising the first spring rate, the first porosity, and/or the first density and a second portion 1194 comprising a second spring rate, a second porosity, and/or a second density, which can be different from the first spring rate, the first porosity, and/or the first density, respectively. The second portion 1194 may correspond to the protruding portion 1196 and can result from the leveling, or at least substantially leveling, of the protruding portion 1196 to form the flat, or at least substantially flat, surface 1198, for example. In certain respects, the geometry of the protruding portion 1196 prior to the modification of the tissue thickness compensator 1190 mirrors, matches, or resembles the geometry of the second portion 1194 after the tissue thickness compensator 1190 has been modified.

[0177] Referring again to FIGS. 37-39, the tissue thickness compensator 1190 can be altered or modified using the mold 1172, in a similar manner to the tissue thickness compensator 1170. For example, the tissue thickness compensator 1190 can be heated in the receiver 1174 to a temperature greater than or equal to a glass transition temperature of the material composition of the tissue thickness compensator 1190 but less than the melting temperature of the same. In certain circumstances, the adjustment member 1176 can be advanced against the protruding portion 1196, while the tissue thickness compensator 1190 is in the glassy state, thereby compressing the protruding portion 1196 and rearranging its geometry to form the second portion 1194, as illustrated in FIG. 39. Further to the above, the adjustment member 1176 can be configured to maintain compression against the protruding portion 1196 for a time period sufficient to permit the tissue thickness compensator 1190 to retain, or at least substantially retain, the modification imposed by the adjustment member 1176. The tissue thickness compensator 1190 can be allowed to cool or can be actively cooled to a temperature below its glass transition temperature while under compression from the adjustment member 1176. After transitioning the tissue thickness compensator 1190 out of the glassy state, the adjustment member 1190 can be retracted. The tissue thickness compensator 1190 may retain, or at least substantially retain, the second portion 1194, as illustrated in FIG. 39. In certain circumstances, the adjustment member 1176 may apply pressure onto the protruding portion 1196 while the tissue thickness compensator 1190 is heated to reach the glassy state, while the tissue thickness compensator 1190 is in the glassy state, and/or while the tissue thickness compensator 1190 is transitioned or cooled to a temperature below the glassy state. In certain circumstances, the pressure applied to the protruding portion 1196 of the tissue thickness compensator 1190 can be gradually increased toward a threshold as the temperature of the tissue thickness compensator 1190 is gradually increased to transition the tissue thickness compensator 1190 toward the glassy state, for example. In certain

circumstances, the pressure applied to the protruding portion 1196 of the tissue thickness compensator 1190 can be removed, gradually removed, or at least partially reduced as the tissue thickness compensator 1190 exits the glassy state, before the tissue thickness compensator 1190 exits the glassy state, and/or after the tissue thickness compensator 1190 exits the glassy state.

[0178] Referring now to FIGS. 41-43, a tissue thickness compensator such as, for example, tissue thickness compensator 1200 can be prepared using traditional lyophilization techniques and/or any other suitable techniques. In addition, the tissue thickness compensator 1200 can be modified or altered for use in a surgical procedure, for example. The tissue thickness compensator 1200 can be similar in many respects to other tissue thickness compensators such as, for example, the tissue thickness compensator 22020 (FIG. 9) and/or the tissue thickness compensator 1120 (FIG. 26). For example, like the tissue thickness compensator 22020, the tissue thickness compensator 1200 can be utilized with the end effector 22090. Furthermore, as illustrated in FIGS. 41-43, the tissue thickness compensator 1200 can be modified to include a longitudinal slot 1202 which, like the knife slot 22025, may define a tissue thickness compensator knife path for the cutting portion 10053 between a first stapling portion 1204a and a second stapling portion 1204b. Furthermore, the first stapling portion 1204a and the second stapling portion 1204b can be similar in many respects to the first stapling portion 22021a (FIG. 9) and the second stapling portion 22021b (FIG. 9) of the tissue thickness compensator 22020. In addition, the slot 1202 can be configured to releasably connect the first stapling portion 1204a and the second stapling portion 1204b such that, in use with the end effector 22090, the cutting portion 10053 can be advanced distally through the slot 1202 to transect the slot 1202 and separate the first stapling portion 1204a and the second stapling portion 1204b.

[0179] Referring again to FIGS. 41-43, the tissue thickness compensator 1200 can be modified prior to assembly with an end effector such as, for example, the end effector 22090 (FIG.9). Alternatively, the tissue thickness compensator 1200 can be modified after it has been assembled with an end effector. As described above, the tissue thickness compensator 1200 can be prepared using traditional lyophilization techniques and/or any other suitable techniques. A space creator 1206 can be utilized to modify the tissue thickness compensator 1200 in a thermal pressing process, as illustrated in FIGS. 41-43. For example, the space creator 1206 can be heated to a temperature greater than or equal to a melting temperature of the material composition of the tissue thickness compensator 1200. The space creator 1206 can then be aligned with and inserted into the tissue thickness compensator 1200 to form the longitudinal slot 1202. The space creator 1206 may melt through the tissue thickness compensator 1200 to create space for the longitudinal slot 1202. The space creator 1206 can be retracted upon reaching a desired depth within the tissue thickness compensator 1200. In certain circumstances, the thermal pressing process can be repeated by reinserting the heated space creator 1206 through the tissue thickness compensator 1200 to widen the space created for the longitudinal slot 1202.

[0180] Referring again to FIGS. 41-43, the space creator 1206 may comprise a hot wire. For example, the space creator 1206 may comprise a thin, taut metal wire, which can be made of nichrome or stainless steel, for example, or a thicker wire preformed into a desired shape. The hot wire can be heated via electrical resistance to a desired temperature. As the hot wire of the space creator 1206 is passed through the material of the tissue thickness compensator 1200, the heat from the hot wire may vaporize the material just in advance of contact. In certain

circumstances, the hot wire may comprise a cylindrical, or substantially cylindrical, shape, as illustrated in FIG. 42. The depth of the longitudinal slot 1202 can depend, in part, on the insertion depth of the space creator 1206 through the tissue thickness compensator 1200 and the width of the longitudinal slot 1202 can depend, in part, on the diameter of the hot wire of the space creator 1206.

[0181] In certain instances, the space creator 1206 can be partially inserted through the full thickness of the tissue thickness compensator. In certain instances, the space creator 1206 can be completely inserted through the full thickness of the tissue thickness compensator 1200 to create openings, holes, and/or slots extending through the full thickness of the tissue thickness compensator 1200. In certain instances, the space creator 1206 may be inserted through a first side of the tissue thickness compensator 1200 and exited through a second side of the tissue thickness compensator 1200 which may be opposite the first side, for example.

[0182] Many processes are disclosed herein which utilize thermal energy to modify a tissue thickness compensator. Such processes can be referred to as felting processes. In certain instances, a felting process may also utilize the application of compressive and/or tensile forces to a tissue thickness compensator. In other instances, a felting process may not utilize the application of compressive and/or tensile forces to a tissue thickness compensator. In either event, the felting processes disclosed herein can also be utilized to modify and suitable implantable layer and/or buttress material, for example.

[0183] In various circumstances, the tissue thickness compensator assembly may comprise a polymeric composition. The polymeric composition may comprise one or more synthetic polymer and/or one or more non-synthetic polymer. The synthetic polymer may comprise a synthetic absorbable polymer and/or a synthetic non-absorbable polymer. In various circumstances, the polymeric composition may comprise a biocompatible foam, for example. The biocompatible foam may comprise a porous, open cell foam and/or a porous, closed cell foam, for example. The biocompatible foam can have a uniform pore morphology or may have a gradient pore morphology (i.e. small pores gradually increasing in size to large pores across the thickness of the foam in one direction). In various circumstances, the polymeric composition may comprise one or more of a porous scaffold, a porous matrix, a gel matrix, a hydrogel matrix, a solution matrix, a filamentous matrix, a tubular matrix, a composite matrix, a membranous matrix, a biostable polymer, and a biodegradable polymer, and combinations thereof. For example, the tissue thickness compensator assembly may comprise a foam reinforced by a filamentous matrix or may comprise a foam having an additional hydrogel layer that expands in the presence of bodily fluids to further provide the compression on the tissue. In various circumstances, a tissue thickness compensator assembly could also be comprised of a coating on a material and/or a second or third layer that expands in the presence of bodily fluids to further provide the compression on the tissue. Such a layer could be a hydrogel that could be a synthetic and/or naturally derived material and could be either biodurable and/or biodegradable, for example. In certain circumstances, a tissue thickness compensator assembly could be reinforced with fibrous non-woven materials or fibrous mesh type elements, for example, that can provide additional flexibility, stiffness, and/or strength. In various circumstances, a tissue thickness compensator assembly that has a porous morphology which exhibits a gradient structure such as, for example, small pores on one surface and larger pores on the other surface. Such morphology could be more optimal for tissue in-growth or hemostatic behavior. Further, the gradient could be also compositional with a varying bio-

absorption profile. A short term absorption profile may be preferred to address hemostasis while a long term absorption profile may address better tissue healing without leakages.

[0184] Examples of non-synthetic polymers include, but are not limited to, lyophilized polysaccharide, glycoprotein, elastin, proteoglycan, gelatin, collagen, and oxidized regenerated cellulose (ORC). Examples of synthetic absorbable polymers include, but are not limited to, poly(lactic acid) (PLA), poly(L-lactic acid) (PLLA), polycaprolactone (PCL), polyglycolic acid (PGA), poly(trimethylene carbonate) (TMC), polyethylene terephthalate (PET), polyhydroxyalkanoate (PHA), a copolymer of glycolide and ϵ -caprolactone (PGCL), a copolymer of glycolide and trimethylene carbonate, poly(glycerol sebacate) (PGS), polydioxanone, poly(orthoesters), polyanhydrides, polysaccharides, poly(ester-amides), tyrosine-based polyarylates, tyrosine-based polyiminocarbonates, tyrosine-based polycarbonates, poly(D,L-lactide-urethane), poly(B-hydroxybutyrate), poly(E-caprolactone), polyethyleneglycol (PEG), poly[bis(carboxylatophenoxy) phosphazene], poly(amino acids), pseudo-poly(amino acids), absorbable polyurethanes, and combinations thereof. In various circumstances, the polymeric composition may comprise from approximately 50% to approximately 90% by weight of the polymeric composition of PLLA and approximately 50% to approximately 10% by weight of the polymeric composition of PCL, for example. In at least one embodiment, the polymeric composition may comprise approximately 70% by weight of PLLA and approximately 30% by weight of PCL, for example. In various circumstances, the polymeric composition may comprise from approximately 55% to approximately 85% by weight of the polymeric composition of PGA and 15% to 45% by weight of the polymeric composition of PCL, for example. In at least one embodiment, the polymeric composition may comprise approximately 65% by weight of PGA and approximately 35% by weight of PCL, for example. In various circumstances, the polymeric composition may comprise from approximately 90% to approximately 95% by weight of the polymeric composition of PGA and approximately 5% to approximately 10% by weight of the polymeric composition of PLA, for example.

[0185] In various circumstances, the synthetic absorbable polymer may comprise a bioabsorbable, biocompatible elastomeric copolymer. Suitable bioabsorbable, biocompatible elastomeric copolymers include but are not limited to copolymers of epsilon-caprolactone and glycolide (preferably having a mole ratio of epsilon-caprolactone to glycolide of from about 30:70 to about 70:30, preferably 35:65 to about 65:35, and more preferably 45:55 to 35:65); elastomeric copolymers of epsilon-caprolactone and lactide, including L-lactide, D-lactide blends thereof or lactic acid copolymers (preferably having a mole ratio of epsilon-caprolactone to lactide of from about 35:65 to about 65:35 and more preferably 45:55 to 30:70) elastomeric copolymers of p-dioxanone (1,4-dioxan-2-one) and lactide including L-lactide, D-lactide and lactic acid (preferably having a mole ratio of p-dioxanone to lactide of from about 40:60 to about 60:40); elastomeric copolymers of epsilon-caprolactone and p-dioxanone (preferably having a mole ratio of epsilon-caprolactone to p-dioxanone of from about 30:70 to about 70:30); elastomeric copolymers of p-dioxanone and trimethylene carbonate (preferably having a mole ratio of p-dioxanone to trimethylene carbonate of from about 30:70 to about 70:30); elastomeric copolymers of trimethylene carbonate and glycolide (preferably having a mole ratio of trimethylene carbonate to glycolide of from about 30:70 to about 70:30); elastomeric copolymer of trimethylene carbonate and lactide including L-lactide, D-lactide, blends thereof or lactic acid copolymers (preferably having a mole ratio of trimethylene carbonate to lactide of from about 30:70 to about 70:30) and blends thereof. In one

embodiment, the elastomeric copolymer is a copolymer of glycolide and epsilon-caprolactone. In another embodiment, the elastomeric copolymer is a copolymer of lactide and epsilon-caprolactone.

[0186] The disclosures of U.S. Patent No. 5,468,253, entitled ELASTOMERIC MEDICAL DEVICE, which issued on November 21, 1995, and U.S. Patent No. 6,325,810, entitled FOAM BUTTRESS FOR STAPLING APPARATUS, which issued on December 4, 2001, are hereby incorporated by reference in their respective entireties.

[0187] In various circumstances, the synthetic absorbable polymer may comprise one or more of 90/10 poly(glycolide-L-lactide) copolymer, commercially available from Ethicon, Inc. under the trade designation VICRYL (polyglactin 910), polyglycolide, commercially available from American Cyanamid Co. under the trade designation DEXON, polydioxanone, commercially available from Ethicon, Inc. under the trade designation PDS, poly(glycolide-trimethylene carbonate) random block copolymer, commercially available from American Cyanamid Co. under the trade designation MAXON, 75/25 poly(glycolide-E-caprolactone-polyepsilon-caprolactone 25) copolymer, commercially available from Ethicon under the trade designation MONOCRYL, for example.

[0188] Examples of synthetic non-absorbable polymers include, but are not limited to, foamed polyurethane, polypropylene (PP), polyethylene (PE), polycarbonate, polyamides, such as nylon, polyvinylchloride (PVC), polymethylmethacrylate (PMMA), polystyrene (PS), polyester, polyetheretherketone (PEEK), polytetrafluoroethylene (PTFE), polytrifluorochloroethylene (PTFCE), polyvinylfluoride (PVF), fluorinated ethylene propylene (FEP), polyacetal, polysulfone, and combinations thereof. The synthetic non-absorbable polymers may include, but are not limited to, foamed elastomers and porous elastomers, such as, for example, silicone, polyisoprene, and rubber. In various circumstances, the synthetic polymers may comprise expanded polytetrafluoroethylene (ePTFE), commercially available from W. L. Gore & Associates, Inc. under the trade designation GORE-TEX Soft Tissue Patch and co-polyetherester urethane foam commercially available from Polyganics under the trade designation NASOPORE.

[0189] The polymeric composition of a tissue thickness compensator assembly may be characterized by percent porosity, pore size, and/or hardness, for example. In various circumstances, the polymeric composition may have a percent porosity from approximately 30% by volume to approximately 99% by volume, for example. In certain circumstances, the polymeric composition may have a percent porosity from approximately 60% by volume to approximately 98% by volume, for example. In various circumstances, the polymeric composition may have a percent porosity from approximately 85% by volume to approximately 97% by volume, for example. In at least one embodiment, the polymeric composition may comprise approximately 70% by weight of PLLA and approximately 30% by weight of PCL, for example, and can comprise approximately 90% porosity by volume, for example. In at least one such embodiment, as a result, the polymeric composition would comprise approximately 10% copolymer by volume. In at least one embodiment, the polymeric composition may comprise approximately 65% by weight of PGA and approximately 35% by weight of PCL, for example, and can have a percent porosity from approximately 93% by volume to approximately 95% by volume, for example. In various circumstances, the polymeric composition may comprise a greater than 85% porosity by volume. The polymeric composition may have a pore size from approximately 5 micrometers to approximately 2000 micrometers, for example. In various circumstances, the polymeric composition may have a pore size between approximately 10 micrometers to approximately 100

micrometers, for example. In at least one such embodiment, the polymeric composition can comprise a copolymer of PGA and PCL, for example. In certain circumstances, the polymeric composition may have a pore size between approximately 100 micrometers to approximately 1000 micrometers, for example. In at least one such embodiment, the polymeric composition can comprise a copolymer of PLLA and PCL, for example. According to certain aspects, the hardness of a polymeric composition may be expressed in terms of the Shore Hardness, which can be defined as the resistance to permanent indentation of a material as determined with a durometer, such as a Shore Durometer. In order to assess the durometer value for a given material, a pressure is applied to the material with a durometer indenter foot in accordance with ASTM procedure D2240-00, entitled, "Standard Test Method for Rubber Property-Durometer Hardness", the entirety of which is incorporated herein by reference. The durometer indenter foot may be applied to the material for a sufficient period of time, such as 15 seconds, for example, wherein a reading is then taken from the appropriate scale. Depending on the type of scale being used, a reading of 0 can be obtained when the indenter foot completely penetrates the material, and a reading of 100 can be obtained when no penetration into the material occurs. This reading is dimensionless. In various circumstances, the durometer may be determined in accordance with any suitable scale, such as Type A and/or Type OO scales, for example, in accordance with ASTM D2240-00. In various circumstances, the polymeric composition of a tissue thickness compensator assembly may have a Shore A hardness value from approximately 4 A to approximately 16 A, for example, which is approximately 45 OO to approximately 65 OO on the Shore OO range. In at least one such embodiment, the polymeric composition can comprise a PLLA/PCL copolymer or a PGA/PCL copolymer, for example. In various circumstances, the polymeric composition of a tissue thickness compensator assembly may have a Shore A Hardness value of less than 15 A. In various circumstances, the polymeric composition of a tissue thickness compensator assembly may have a Shore A Hardness value of less than 10 A. In various circumstances, the polymeric composition of a tissue thickness compensator assembly may have a Shore A Hardness value of less than 5 A. In certain circumstances, the polymeric material may have a Shore OO composition value from approximately 35 OO to approximately 75 OO, for example.

[0190] In various circumstances, the polymeric composition may have at least two of the above-identified properties. In various circumstances, the polymeric composition may have at least three of the above-identified properties. The polymeric composition may have a porosity from 85% to 97% by volume, a pore size from 5 micrometers to 2000 micrometers, and a Shore A hardness value from 4 A to 16 A and Shore OO hardness value from 45 OO to 65 OO, for example. In at least one embodiment, the polymeric composition may comprise 70% by weight of the polymeric composition of PLLA and 30% by weight of the polymeric composition of PCL having a porosity of 90% by volume, a pore size from 100 micrometers to 1000 micrometers, and a Shore A hardness value from 4 A to 16 A and Shore OO hardness value from 45 OO to 65 OO, for example. In at least one embodiment, the polymeric composition may comprise 65% by weight of the polymeric composition of PGA and 35% by weight of the polymeric composition of PCL having a porosity from 93% to 95% by volume, a pore size from 10 micrometers to 100 micrometers, and a Shore A hardness value from 4 A to 16 A and Shore OO hardness value from 45 OO to 65 OO, for example.

[0191] In various circumstances, the polymeric composition may comprise a pharmaceutically active agent. The polymeric composition may release a therapeutically effective amount of the pharmaceutically active agent. In

various circumstances, the pharmaceutically active agent may be released as the polymeric composition is desorbed/absorbed. In various circumstances, the pharmaceutically active agent may be released into fluid, such as, for example, blood, passing over or through the polymeric composition. Examples of pharmaceutically active agents may include, but are not limited to, hemostatic agents and drugs, such as, for example, fibrin, thrombin, and oxidized regenerated cellulose (ORC); anti-inflammatory drugs, such as, for example, diclofenac, aspirin, naproxen, sulindac, and hydrocortisone; antibiotic and antimicrobial drug or agents, such as, for example, triclosan, ionic silver, ampicillin, gentamicin, polymyxin B, chloramphenicol; and anticancer agents, such as, for example, cisplatin, mitomycin, adriamycin.

[0192] Various methods are disclosed herein for altering a tissue thickness compensator. Such methods could be used to alter any suitable layer for use with a fastener cartridge and/or a surgical fastening instrument, for example. Such a layer can comprise a less than one hundred percent dense composition which can be created utilizing any suitable process. For instance, such processes can include, for example, extruding, injection molding, weaving, lyophilization, gas-foaming, and/or melt-blowing processes. Some processes may produce a foam while other processes may not produce a foam; however, in any event, all such embodiments are contemplated for use with all of the embodiments disclosed herein.

[0193] In various embodiments, referring to FIGS. 44-46, an end effector of a surgical fastening instrument, such as end effector 100, for example, can be configured to capture, fasten, and/or incise tissue. The end effector 100 can include a fastener cartridge 110 and, in addition, a firing member 140 which can be advanced through the fastener cartridge 110 to deploy staples removably stored within the staple cartridge 110 into tissue captured within the end effector 100. In various instances, the firing member 140 can be advanced from a proximal position (FIG. 44) toward a distal end of the end effector 100 to simultaneously deploy the staples and transect the tissue. There are some circumstances, however, where it may not be desirable to advance the firing member 140 toward the distal end of the end effector 100. For instance, the fastener cartridge 110 of the end effector 100 can be removable and/or replaceable and, in the event that a fastener cartridge 110 is not positioned within the end effector 100, it may not be desirable for the firing member 140 to be advanced within the end effector 100. In the event that the firing member 140 were to be advanced through the end effector 100 without a fastener cartridge positioned within the end effector 100, a knife edge 142 of the firing member 140 may incise tissue captured within the end effector 100 without simultaneously fastening the tissue. Similarly, in the event that the fastener cartridge positioned within the end effector 100 has been previously used, or expended, and at least some of the fasteners have been deployed from the fastener cartridge, it may not be desirable for the firing member 140 to be advanced within the end effector 100. In the event that the firing member 140 were to be advanced through the end effector 100 with a previously expended fastener cartridge positioned within the end effector 100, the knife edge 142 of the firing member 140 may incise tissue captured within the end effector 100 without simultaneously fastening the tissue. In various embodiments, the end effector 100 can include one or more lockout systems which can prevent the firing member 140 from being advanced distally when a fastener cartridge is not present within the end effector 100 and/or when the fastener cartridge positioned within the end effector 100 has been at least partially expended. Various lockout systems are disclosed in U.S. Patent No. 6,988,649, entitled SURGICAL STAPLING INSTRUMENT HAVING A SPENT CARTRIDGE LOCKOUT, and issued on January 24,

2006. The entire disclosure of U.S. Patent No. 6,988,649, entitled SURGICAL STAPLING INSTRUMENT HAVING A SPENT CARTRIDGE LOCKOUT, is incorporated by reference herein.

[0194] Referring again to FIGS. 44-46, the fastener cartridge 110 can include a cartridge body and a tissue thickness compensator 120 wherein, further to the above, the tissue thickness compensator 120 can be implanted against tissue captured by the end effector 100 by fasteners removably stored within the cartridge body. The tissue thickness compensator 120 can be positioned above a top surface, or deck, of the cartridge body wherein staples 180 removably stored within staple cavities defined in the cartridge body can be ejected from the staple cavities by a firing member, such as sled 130 and/or firing member 140, for example. In certain embodiments, the fastener cartridge 110 can further include drivers configured to support the staples 180 and transmit the movement of the sled 130 to the staples 180 in order to move the staples 180 between an unfired position and a fired position. In various instances, the staples 180 can be at least partially embedded in the tissue thickness compensator 120 when the staples 180 are in their unfired positions and, in certain instances, the staples 180 can hold the tissue thickness compensator 120 in position over the cartridge deck when the staples 180 are in their unfired position. In the event that the tissue thickness compensator 120 were to be moved relative to the cartridge body and/or the staples 180 prior to deploying the staples 180 into tissue, in some instances, the tissue thickness compensator 120 may move the staples 180 relative to or away from their preferred positions. Moreover, in the event that the tissue thickness compensator 120 were to be removed from the cartridge 110 prior to the staples 180 being deployed, the cartridge 110 may no longer be suitable for its originally intended use. In view of the foregoing, as discussed in greater detail below, the end effector 100 may include a lockout configured to prevent the firing member 140 and/or the sled 130 from being advanced distally to deploy the staples 180 in the event that the tissue thickness compensator 120 is removed from, or becomes at least partially dislodged from, the cartridge body prior to the staples 180 being deployed.

[0195] Referring again to FIGS. 44-46, the tissue thickness compensator 120 can comprise, one, a body 121 configured to be captured by the staples 180 and, two, a lockout pin 122 extending from the body 121. In various instances, the lockout pin 122 can include a first end 123 embedded in the body 121 and a second end 124 positioned intermediate the firing member 140 and the sled 130 when the tissue thickness compensator 120 has not been removed from or substantially moved from a suitable position over the cartridge body deck. In such a position, the second end 124 of the lockout pin 122 can be positioned intermediate a shoulder, or shelf, 134 defined on the sled 130 and a protrusion 144 extending distally from the firing bar 140. Stated another way, when the lockout pin 122 is positioned intermediate the sled 130 and the firing bar 140, the lockout pin 122 and the sled 130 can co-operate to support the firing bar 140 in an unlocked position above a lockout shoulder 112 defined in the fastener cartridge 110 such that, when a distal firing force is applied to the firing bar 140, the firing bar 140 can advance the sled 130 distally to fire the staples 180. When the tissue thickness compensator 120 is removed from the cartridge 110 and/or sufficiently dislodged from a desirable position relative to the cartridge body, referring primarily to FIG. 45, the lockout pin 122 may no longer be positioned intermediate the sled 130 and the firing member 140 and/or may otherwise be unable to support the firing member 140 in its unlocked position (FIG. 44). In such circumstances, the firing member 140 may become positioned in a locked position such that the distal advancement of the firing member 140 is prevented by the lockout shoulder 112. In at least one such circumstance, the end effector 100 can further include a biasing member,

such as a spring, for example, configured to bias the firing member 140 into its locked condition. In certain circumstances, the biasing member can bias the firing member 140 into contact with the sled 130, for instance, without the lockout pin 122 positioned therebetween which can comprise the locked position of the firing member 140.

[0196] As a result of the above, the cartridge 110 may become inoperable if the tissue thickness compensator 120 is prematurely removed from the cartridge 110. In such circumstances, the lockout pin 122 may comprise a fuse which deactivates the cartridge 110 in the event that the tissue thickness compensator 120 is removed before the firing member 140 is advanced distally. In various circumstances, the lockout pin 122 may comprise a key which maintains the cartridge 110 in an unlocked condition when the key is positioned between the sled 130 and the firing member 140 and permits the cartridge 110 to enter into a locked condition in the event that the tissue thickness compensator 120 is removed from the cartridge 110 before the firing member 140 is advanced distally, i.e., before the firing member 140 begins its firing stroke. When the firing member 140 is in its locked-out condition and cannot be advanced distally, the knife edge 142 of the firing member 140 is unable to incise the tissue captured within the end effector 100. Moreover, in such circumstances, the firing member 140 cannot advance the sled 130 distally to fire the staples 180. Thus, the tissue thickness compensator lockout can prevent the tissue captured within the end effector 100 from being incised and stapled when the tissue thickness compensator 120 is not positioned on, or properly positioned on, the cartridge 110. In the event that the firing member 140 is advanced distally before the tissue thickness compensator 120 is removed, or dislodged, the firing member 140 can complete the firing stroke, or at least a portion of the firing stroke, of the end effector 100. In such instances, the sled 130 is advanced distally so that one or more ramps 132 defined on the sled 130 can lift the staples 180 and that a knife edge 142 of the firing member 140 can incise the tissue thickness compensator 120 and/or the tissue captured within the end effector 100. In some circumstances, the firing member 140 can contact the lockout pin 122 and displace it out of the way as the firing member 140 is advanced distally. In such circumstances, the lockout pin 122 can be flexible. In various instances, the lockout pin 122 can be comprised of a bioabsorbable material and/or a biocompatible material, for example. In certain circumstances, the firing member 140 can incise the lockout pin 122 as the firing member 140 is advanced distally. In any event, the purpose of the lockout pin 122 may become obsolete once the firing member 140 has been at least partially advanced. Stated another way, the tissue thickness compensator lockout can serve as an initial check to verify that a tissue thickness compensator is present within the end effector and, once that initial check has been made, the firing stroke of the end effector can proceed.

[0197] Referring again to FIGS. 47-50, an end effector 200 can comprise an anvil 260 and, in addition, a fastener cartridge 210 including a cartridge body 214 and a tissue thickness compensator 220 wherein, further to the above, the tissue thickness compensator 220 can be implanted against tissue captured by the end effector 200 by fasteners removably stored within the cartridge body 214. The tissue thickness compensator 220 can be positioned above a top surface, or deck, 211 of the cartridge body 214 wherein staples removably stored within staple cavities defined in the cartridge body 214 can be ejected from the staple cavities by a firing member, such as a sled 230 and/or a firing member 240, for example. In certain embodiments, the fastener cartridge 210 can further include drivers configured to support the staples and transmit the movement of the sled 230 to the staples in order to move the staples between an

unfired position and a fired position. In various instances, the staples can be at least partially embedded in the tissue thickness compensator 220 when the staples are in their unfired positions and, in certain instances, the staples can hold the tissue thickness compensator 220 in position when the staples are in their unfired position. In the event that the tissue thickness compensator 220 were to be moved relative to the cartridge body 214 and/or the staples prior to deploying the staples into the tissue, in some instances, the tissue thickness compensator 220 may move the staples relative to or away from their preferred positions. Moreover, in the event that the tissue thickness compensator 220 were to be removed from the cartridge 210 prior to the staples being deployed, the cartridge 210 may no longer be suitable for its originally intended use. In view of the foregoing, as discussed in greater detail below, the end effector 200 may include a lockout configured to prevent the firing member 240 and/or the sled 230 from being advanced distally to deploy the staples in the event that the tissue thickness compensator 220 is removed from, or becomes at least partially dislodged from, the cartridge body 214 prior to the staples being deployed.

[0198] Referring again to FIGS. 44-46, the tissue thickness compensator 220 can comprise, one, a body 221 configured to be captured by the staples and, two, a loop, or tether, 222 extending from the body 221. In various instances, referring primarily to FIG. 47, the loop 222 can comprise ends which are at least partially embedded in the body 221 and an intermediate portion extending between the ends which can be releasably engaged with the sled 230. In certain instances, the loop 222 can comprise a suture or flexible thread, for example. In some instances, the loop 222 can be comprised of a bioabsorbable material and/or a biocompatible material, for example. Referring primarily to FIG. 48, the sled 230 can include a longitudinal body portion 236, a hook 238 extending from the body portion 236, and a slot 237 defined between the body portion 236 and the hook 238. As illustrated in FIG. 48, the loop 222 is positioned within the slot 237 when the tissue thickness compensator 220 is positioned over the cartridge deck 211 and the sled 230 and the firing member 240 are in an unfired position. As also illustrated in FIG. 48, a distal projection 244 extending from the firing member 240 is positioned against and/or above a support shoulder 234 defined on the sled 230 which holds the firing member 240 in an unlocked position, i.e., in a position in which the distal movement of the firing member 240 will not be impeded, or at least substantially impeded, by a lockout shoulder 212 defined in the end effector 200 when a firing motion is applied to the firing member 240. Thus, when the sled 230 holds the firing member 240 in its unlocked position, referring to FIG. 49, the firing member 240 will slide past the lockout shoulder 212 to advance the sled 230 distally, fire the staples removably stored within the cartridge body 214, and incise the tissue thickness compensator and the tissue positioned within the end effector 200 with a knife edge 242. As illustrated in FIG. 49, the loop 222 can slide out of the slot 237 defined in the sled 230 when the sled 230 is advanced distally.

[0199] In the event that the tissue thickness compensator 220 is removed from the cartridge 210 or substantially moved from a suitable position over the deck 211 of the cartridge 210, referring now to FIG. 50, the tissue thickness compensator 220 can pull the sled 230 distally such that the firing member 240 is no longer supported by the sled 230. More particularly, the loop 222 of the tissue thickness compensator 220 positioned within the slot 237 can pull the sled 230 distally from its unfired position such that the support shoulder 234 is no longer positioned under the distal projection 244 of the firing member 240. In such circumstances, the firing member 240 may shift downwardly into a locked position wherein the distal movement of the firing member 240 can be impeded by the lockout shoulder 212.

In certain circumstances, the end effector 200 can further include a biasing member, such as a spring, for example, which can bias the firing member 240 into its locked condition. When the firing member 240 is in its locked condition, the firing member 240 cannot be moved distally to advance the sled 230, fire the staples from the cartridge body 210, and/or incise the tissue captured within the end effector 200. Although the sled 230 may be advanced distally when the tissue thickness compensator 220 is removed from the cartridge 210, the sled 230, in various circumstances, may not be advanced sufficiently to deploy the staples from the cartridge 210. When the user of the surgical instrument recognizes that the firing member 240 is in a locked-out condition, the user can remove the staple cartridge 210 from the end effector 200 and replace it with a staple cartridge 210, for example, in which the tissue thickness compensator 220 is correctly positioned over the deck 211 and the sled 230 has not been advanced distally from its unfired position. Other embodiments are contemplated in which a staple cartridge is not removable from the end effector; in such embodiments, the end effector may be entirely replaced in the event that the tissue thickness compensator is removed from the staple cartridge and/or the firing member enters into a locked-out condition.

[0200] Turning now to FIGS. 51-53, a staple cartridge 310 can include a cartridge body 314 and a sled 330 movably positioned within the cartridge body 314. Similar to the above, the cartridge body 314 can include a plurality of fastener cavities, such as fastener cavities 316, for example, and a longitudinal slot, such as knife slot 318, for example, defined therein. The sled 330 can include a central body portion 336 slidably positioned within the knife slot 318 and a hook 338 extending from the central body portion 336. Referring primarily to FIG. 51, a tissue thickness compensator 320 of the cartridge 310 can include a body portion 321 and a catch 322 extending from the body portion 321 wherein the catch 322 can be releasably retained in a slot 337 defined between the hook 338 and the central body portion 336 when the sled 330 is in its unfired, or unadvanced, position. Similar to the above, the catch 322 can include ends 323 mounted within the body 321 and can extend proximally from the body 321 of the tissue thickness compensator 320 wherein, in the event that the tissue thickness compensator 320 is removed from the cartridge body 314, for instance, the catch 322 can pull the sled 330 distally such that a support shoulder 334 defined in the central body portion 336 is no longer able to support a firing member, such as firing member 240, for example, thereon and such that the firing member may enter a locked out state. In various instances, a user of the surgical instrument may attempt to reassemble or reposition the tissue thickness compensator 320 over the deck 311 of the cartridge body 314; however, the firing member 340 will still remain in a locked out condition as the repositioning of the tissue thickness compensator 320 will not reset the sled 330. Thus, such an arrangement can prevent the cartridge 310 from being used if it has been previously tampered with.

[0201] In various instances, referring again to FIGS. 51-53, at least a portion of the hook 338 extending from the central portion 336 of the sled 330 and/or the slot 337 defined therebetween can extend above the deck 311. In certain instances, at least a portion of the hook 338 extending from the central portion 336 of the sled 330 and/or the slot 337 defined therebetween can extend above the knife slot 318. In such embodiments, the catch 322 can be easily slid into the slot 337 when the tissue thickness compensator 320 is assembled to the cartridge body 314. In certain instances, the catch 322 can be positioned above or against the deck surface 311 of the cartridge body 314. In various instances, referring primarily to FIG. 53, the cartridge body 314 can include a recess or pocket 319 defined therein within which the hook 338 can be positioned when the sled 330 is in its unfired, or unadvanced, position. In such an embodiment,

the top of the hook 338 may be positioned below the deck surface 311. In various instances, the pocket 319 can further include one or more ramped surfaces 313 which are defined in the distal end of the pocket 319 and extend downwardly from the deck surface 311. In some instances, the catch 322 can abut the ramped surfaces 313 when the sled 330 is advanced distally and, in such circumstances, the hook 338 can then separate from the catch 322. In various instances, the recess 319 can be configured to facilitate the assembly of the catch 322 to the sled 330 when the tissue thickness compensator 320 is assembled to the cartridge body 314. In various embodiments, the slot 337 can extend longitudinally and can include a closed distal end an open proximal end wherein the catch 322 can be slid into the slot 337 from the open proximal end. In the event that the tissue thickness compensator 320 is not prematurely removed or dislodged from the cartridge 314, the sled 330 can be advanced distally such that the catch 322 exits the slot 337 through the distal end thereof and such that ramps 332 defined on the sled 330 can eject the staples from the staple cartridge 310.

[0202] In various instances, a tissue thickness compensator can be adhered to a sled utilizing at least one adhesive. In such instances, the adhesive attachment between the tissue thickness compensator and the sled can be strong enough to permit the tissue thickness compensator to pull the sled distally in the event that the tissue thickness compensator is removed from the cartridge. When the sled is advanced distally by the firing member as part of the firing stroke, the adhesive attachment between the tissue thickness compensator and the sled may fail thereby permitting the sled to slide distally relative to the tissue thickness compensator. In various instances, a tissue thickness compensator can be bonded to a sled utilizing a heat steak process and/or a thermoform process. In such instances, the bond between the tissue thickness compensator and the sled can be strong enough to permit the tissue thickness compensator to pull the sled distally in the event that the tissue thickness compensator is removed from the cartridge. When the sled is advanced distally by the firing member as part of the firing stroke, the bond between the tissue thickness compensator and the sled may fail thereby permitting the sled to slide distally relative to the tissue thickness compensator.

[0203] In some instances, a loop, a catch, and/or tag, for example, can be integrally formed with a tissue thickness compensator. In various instances, the loop, catch, and/or tag, for example, can comprise a unitary piece of material with the tissue thickness compensator. In some instances, an additional layer can be attached to the tissue thickness compensator. This layer, in various instances, can comprise a mounting portion engaged with the sled.

[0204] Turning now to FIG. 54, a sled 430 can include, similar to the above, a central body portion 436 and, in addition, a plurality of ramps 432 which are configured to eject staples removably stored within a cartridge body, for example. Also similar to the above, the body portion 436 can include a hook 438 extending therefrom wherein a slot 437 can be defined between the body portion 436 and the hook 438. In certain instances, the slot 437 can include a closed distal end 437a and an open proximal end 437d. In various instances, the slot 437 can further include a first portion 437b extending in a first direction and a second portion 437c extending in a second direction. In certain instances, the first portion 437b can extend along a longitudinal axis and the second portion 437c can extend along a second axis which is transverse to the longitudinal axis. In at least one such instance, the second portion 437c can extend at an angle relative to the first portion 437b.

[0205] Turning now to FIGS. 55-58, a sled assembly 530 can include a first portion 535 and, in addition, a second portion 536 which is movable relative to the first portion 535 between an unlocked position (FIGS. 55 and 57) and a locked position (FIGS. 56 and 58). The first portion 535 can include, one, a central portion configured to slide within a longitudinal slot, such as a knife slot 518 defined in a staple cartridge 510, for instance, and, two, a plurality of ramps 532 configured to eject staples removably stored within the cartridge 510. The central portion of the first portion 535 can include a first slot 533a and a second slot 533b defined therein. The first slot 533a and the second slot 533b can be configured to receive pins 531a and 531b, respectively, extending from the second portion 536. The first pin 531a can be configured to slide within the first slot 533a and the second pin 531b can be configured to slide within the second slot 533b in order to permit the second portion 536 to rotate relative to the first portion 535. In various instances, the first pin 531a can be closely received within the first slot 533a such that the first slot 533a can constrain the motion of the first pin 531a along a first path and, similarly, the second pin 531b can be closely received within the second slot 533b such that the second slot 533b can constrain the motion of the second pin 531b along a second path. Referring primarily to FIG. 57, the second portion 536 of the sled assembly 530 can comprise an arm configured to slide within the knife slot 518 wherein the arm can include a support shoulder 534 defined on the proximal end thereof and a hook 538 defined on the distal end thereof. Similar to the above, the support shoulder 534 can be configured to support a firing member 240, for example, in an unlocked position when the sled assembly 530 is in a proximal, unfired position and the tissue thickness compensator 220, for instance, is positioned over and/or against the deck surface 511 of the cartridge 510. Also similar to the above, the hook 538 can be configured to releasably hold the loop 222 of the tissue thickness compensator 220 such that, in the event that the tissue thickness compensator 220 were to be removed from and/or substantially displaced relative to the cartridge body, the loop 222 could pull on the second portion 536 to pivot the second portion 536 into its locked position as illustrated in FIG. 58. In such a locked position of the second portion 536, the support shoulder 534 may no longer support the distal projection 244 of the firing member 240 and the firing member 240 can drop downwardly into its locked position. As depicted in FIG. 58, the rotation of the second portion 536 into its locked position can move the support shoulder 534 distally and/or downwardly away from the firing member 240. As also depicted in FIG. 58, the firing member 240 can include a lock 541 extending from opposite sides thereof which can be configured to abut the lockout shoulder 212 when the firing member 240 is in its locked position. When the firing member 240 is held in its unlocked position by the sled assembly 530, the locks 541 may not contact the lockout shoulder 212 and the firing member 240 can be advanced through the cartridge 510.

[0206] In various instances, as discussed above, a portion of a staple-driving sled may extend above the deck surface of a cartridge body. For instance, referring again to FIGS. 52 and 54, the hook 338 of the sled 330 (FIG. 52) and/or the hook 438 of the sled 430, for example, can extend above the deck surface. In such instances, the hook 338 and/or the hook 438 can translate distally above the deck surface and, in some instances, contact the tissue thickness compensator positioned against or above the deck surface. In certain instances, the hook 338 and/or the hook 438 can lift the tissue thickness compensator upwardly away from the cartridge body and facilitate the progressive release of the tissue thickness compensator from the cartridge. For instance, the hook 338 and/or the hook 438 can begin at the proximal end of the tissue thickness compensator and move toward the distal end of the tissue thickness compensator

in order to initially lift the proximal end of the tissue thickness compensator and then progressively lift it away from the cartridge deck until the distal end of the tissue thickness compensator is eventually lifted away from the cartridge body. In other instances, as discussed in greater detail further below, it may be preferable for the portion of the sled contacting the tissue thickness compensator to deflect downwardly and/or otherwise not disturb the tissue thickness compensator as the sled is advanced distally.

[0207] Turning now to FIGS. 59 and 60, a staple cartridge 610 can include a cartridge body 614, a tissue thickness compensator 620 releasably retained to the cartridge body 614, and a sled 630 configured to longitudinally traverse the cartridge body 614 and eject staples removably stored therein. The sled 630 can include a main body portion 635 having a plurality of ramp surfaces defined thereon, a support shoulder 634, and an arm 636 extending from the body portion 635. In various instances, the arm 636 can be assembled to the main body portion 635. For instance, the arm 636 can include a first end embedded in the main body portion 635 and a second end including a hook 638, for example. In various instances, the arm 636 can comprise a cantilever beam extending from the main body portion 635. In certain instances, the arm 636 can be comprised of a resilient and/or flexible material, for example. Similar to the above, a slot 637 can be defined between the hook 638 and the arm 636 which can be configured to releasably hold a portion of the tissue thickness compensator 620 when the sled 630 is in its proximal, unfired position. In the event that the tissue thickness compensator 620 is pulled off of the cartridge body 614, for example, the tissue thickness compensator 620 can pull the sled 630 distally away from a firing member so that the firing member enters into a locked out condition.

[0208] In various instances, further to the above, at least a portion of the arm 636, such as the hook 638, for example, can extend above the deck surface 611 of the cartridge body 614. In certain instances, the arm 636 can be engaged with a loop, for example, extending from the tissue thickness compensator 620 when the sled 630 is in its proximal position (FIG. 59) and, as the sled 630 is advanced distally, the arm 636 can disengage from the loop. As the sled 630 is advanced distally, in certain instances, the arm 636 can contact the body portion 621 of the tissue thickness compensator 620 and flex downwardly. In various instances, the deflected arm 636 can slide within a longitudinal knife slot 618 defined in the cartridge body 614 as the sled 630 is advanced distally. In some instances, referring to FIG. 60, the distal end of the longitudinal slot 618 can be defined by a nose wall, or roof, 619 wherein, when the sled 630 reaches a distal end 617 of the cartridge 610, the arm 636 can slide under the nose wall 619 such that the firing stroke of the end effector can be completed. In some instances, the arm 636 may not be deflected, or substantially deflected, downwardly by the tissue thickness compensator 620 wherein, when the arm 636 reaches the end of the longitudinal slot 618, the arm 636 can contact the nose wall 618 and flex downwardly in order to slide thereunder as illustrated in FIG. 60. In various circumstances, as a result, the flexible arm 636 can permit the firing stroke to be completed and for the sled 630 to be parked at the distal end of the cartridge.

[0209] Turning now to FIG. 61, a sled, such as sled assembly 730, for example, can include a main body portion 735 and a movable arm 736. Similar to the above, the main body portion 735 can include one or more staple-driving ramps 732 and a support shoulder 734 configured to support a firing member in an unlocked position, as described above. The arm 736 can include a first end pivotably and/or rotatably mounted to the main body portion 735 and a second end including a hook 738 configured to be releasably engaged with a tissue thickness compensator, as

described above. When the sled assembly 730 is advanced distally, the hook 738 can detach from the tissue thickness compensator; however, the upper surface of the hook 738 can remain in contact with the bottom surface of the tissue thickness compensator. In such circumstances, the arm 736 can pivot downwardly into the knife slot 318, for example, in order to slide under the tissue thickness compensator. More particularly, the arm 736 can pivot from a raised, or uppermost, position (FIG. 61) to a lowered, or depressed, position. In various instances, the sled assembly 730 can further include a resilient biasing member, such as a spring 731, for example, configured to bias the arm 736 into its raised position. When the arm 736 has been rotated downwardly into its lowered position, the spring 731 can apply a biasing force to the arm 736 which is transmitted into the tissue thickness compensator. In certain instances, the spring 731 can be positioned intermediate the arm 736 and a frame portion 733 defined on the main body portion 735. In various instances, the spring 731 can comprise a cantilever spring or leaf spring, for example, extending from the arm 736. When the arm 736 is pushed downwardly, the cantilever spring can be configured to flex and/or slide along the frame portion 731, for instance. In various embodiments, the main body portion 735 can further include a stop shoulder 739, for example, which can limit the upward rotation, or travel, of the arm 736. In any event, similar to the above, the arm 736 can be configured to rotate downwardly when it contacts the roof 619 and permit the firing stroke to be completed.

[0210] In various instances, a staple can comprise a base and one or more legs extending from the base. In certain instances, a staple can comprise a base including a first end and a second end, a first leg extending from the first end, and a second leg extending from the second end. In some instances, the staple can be formed from a continuous wire which comprises the first leg, the base, and the second leg. A first end of the continuous wire can comprise a tip of the first staple leg and a second end of the continuous wire can comprise a tip of the second staple leg. One such staple, i.e., staple 800, is depicted in FIG. 62, for example. The staple 800 can include a base 802, a first staple leg 804 extending from a first end of the base 802, and a second staple leg 804 extending from a second end of the base 802. The first staple leg 804 can include a first tip 806 and, similarly, the second staple leg 804 can include a second tip 806. In various instances, the tips 806 can be configured to penetrate tissue, such as tissue T depicted in FIG. 62, for example. In some instances, the tips 806 can be sharp and can be formed by a coining process, for example. In various embodiments, the wire can be comprised of titanium and/or stainless steel, for example.

[0211] In various embodiments, the staple 800 can be U-shaped, or at least substantially U-shaped, for example, when it is in its unformed configuration. In such embodiments, the legs 804 of the staple 800 can be parallel, or at least substantially parallel, to one another. Moreover, in such embodiments, the legs 804 can be perpendicular, or at least substantially perpendicular, to the base 802. In certain embodiments, the staple 800 can be V-shaped, or at least substantially V-shaped, for example, when it is in its unformed configuration. In such embodiments, the legs 804 of the staple 800 are not parallel to one another; rather, the legs 804 can extend in non-parallel directions. Moreover, in such embodiments, one or both of the legs 804 are not perpendicular to the base 802 wherein one or both of the legs 804 can extend in directions which are oblique to the base 802. In various instances, the legs 804 may extend, or splay, outwardly with respect to a center or midline of the staple. In any event, the staple 800 can be removably stored within a staple cartridge, ejected from the staple cartridge to penetrate tissue, as illustrated in FIG. 62, and then contact an anvil positioned on the opposite side of the tissue. The anvil can be configured to deform the staple 800 into any

suitable shape, such as a B-form configuration, for example, as also illustrated in FIG. 62. Various formed staple configurations, such as the B-form configuration, for example, can define a tissue entrapment area, such as tissue entrapment area 807, for example, configured to entrap tissue within the staple.

[0212] As discussed above, a staple can be removably stored within a cavity defined in a cartridge body. A cartridge body 810 is depicted in FIG. 63 which can include one or more staple cavities 812 defined therein. Referring to FIGS. 63, 68, and 69, each staple cavity 812 can include a first end 814 and a second end 814. In certain embodiments, such as embodiments including a longitudinal end effector, for example, the first end 814 can comprise a proximal end of the staple cavity 812 and the second end 814 can comprise a distal end of the staple cavity 812. In various instances, a staple can be positioned within a staple cavity 812 such that a first leg 804 of the staple 800 is positioned in the first end 814 of the staple cavity 812 and a second leg 804 is positioned in the second end 814. In various instances, a staple cavity width can be defined between the ends 814 of a staple cavity 812. The base 802 of a staple can be defined by a base width which can be equal to or shorter than the staple cavity width, for example. In certain instances, a staple can comprise a staple width which can be defined between the tips 806 of the staple legs 804. In some embodiments, the staple width can be equal to the staple cavity width. In various embodiments, the staple width can be wider than the staple cavity width. In such embodiments, the legs 804 can be in contact with the ends 814 of a staple cavity 812 and can be resiliently biased inwardly by the ends 814 when the staple is positioned within the staple cavity 812. When the staple is lifted upwardly out of the staple cavity 812, the legs 804 can resiliently splay outwardly as they emerge from the staple cavity 812. For example, the staple can be positioned within the staple cavity 812 such that the tips 806 of the staple legs 804 do not extend above a top surface, or deck, of the cartridge body 810 when the staple is in its unfired, or unlifted, position. In such a position, the tips 806 can be positioned flush with or recessed below the deck 811 of the cartridge body 810. Alternatively, the tips 806 of the legs 804 can at least partially extend above the deck 811 of the cartridge body 810. In any event, as the staple is lifted upwardly, the staple tips 806 can emerge above the deck 811 and splay outwardly as the legs 804 emerge from the cavity 812. At some point during the lifting of the staple, the legs 804 may no longer be in contact with the ends 814 of the staple cavity 812 and the legs 804 may no longer be biased inwardly by the sidewalls of the staple cavity 812.

[0213] In various instances, an anvil can include one or more pockets configured to receive the tips 806 of the staple legs 804 as the staple 800 is ejected from the staple cartridge. The anvil pockets can be configured to turn, or bend, the staple legs 804 inwardly toward one another, for example. In other instances, the anvil pockets can be configured to turn, or bend, the staple legs 804 outwardly away from one another, for example. In some instances, however, one or more of the staple legs of a staple may miss a staple pocket and may not be properly deformed. In certain instances, one or more of the staple legs may not contact the anvil and may not be deformed at all. In either event, the staple may not properly capture and/or retain the tissue within its tissue entrapment area. Moreover, the misformed or unformed staple may not be able to apply a desired compressive pressure to the tissue. In some instances, the misformed or unformed staple may not be retained in the tissue and can become dislodged from the tissue.

[0214] Referring again to FIG. 62, the staple 800, and/or various other staples disclosed herein, can include one or more barbs extending therefrom. In various instances, the barbs can be configured to engage tissue captured within and/or surrounding the staple. In certain instances, the barbs can assist in retaining the staple within the tissue,

especially when the staple has been misformed or unformed. The staple 800 can include barbs extending from one or both of the legs 804. For instance, each leg 804 can include one or more barbs 808 which face outwardly from the center of the staple 800 and/or one or more barbs 809 which face inwardly toward the center of the staple 800, for example. In certain instances, the barbs 808 can extend away from the tissue entrapment area 807 and/or the barbs 809 can extend toward or into the tissue entrapment area 807. As depicted in FIG. 62, both of the staple legs 804 of staple 800 can include barbs 808 and barbs 809. In some instances, the staple legs 804 can include barbs 808, but not barbs 809. A staple 820 is depicted in FIG. 63 which includes barbs 808, but not barbs 809. In some instances, the staple legs 804 can include barbs 809, but not barbs 808. Staples 830, 840, 850, 860, and 870 are depicted in FIGS. 64, 65, 66, 67, and 68, respectively, which include barbs 809, but not barbs 808. In some embodiments, a first leg 804 of a staple can include barbs 808 while a second leg 804 of the staple can include barbs 809, for example.

[0215] In various instances, the legs 804 and the base 802 of a staple can define a staple plane when the staple is in an unformed configuration. The barbs 808 can extend outwardly from the legs 804 within such a staple plane. Similarly, the barbs 809 can extend inwardly from the legs 804 within such a plane. In some instances, a staple can include barbs which extend laterally with respect to such a staple plane. Other embodiments are envisioned in which the legs 804 and the base 802 do not lie within, or entirely lie within, a single plane. In such embodiments, the barbs can extend in any suitable direction. In various embodiments, referring now to FIG. 67, a staple, such as staple 860, for example, can include barbs 803 extending from the base 802. In various instances, the barbs 803 can extend inwardly toward the tissue entrapment area 807 of the staple 860. In certain instances, the barbs 803 can extend outwardly away from the tissue entrapment area 807. As illustrated in FIG. 67, the barbs 803 can extend within a staple plane defined by the legs 804 and the base 802. In certain instances, the barbs 803 can extend laterally with respect to such a staple plane. Various exemplary barb configurations are discussed in greater detail further below.

[0216] In various instances, a staple leg 804 can comprise an array of barbs 808 which extends along the entire length thereof. In some instances, a staple leg 804 can comprise an array of barbs 808 which extends along less than the entire length thereof. By way of example, referring to FIG. 62, the legs 804 of the staple 800 each comprise an array of barbs 808 which extends along less than the entire length of the legs 804. Similarly, referring to FIG. 63, the legs 804 of the staple 820 each comprise an array of barbs 808 which extends along less than the entire length of the legs 804. With regard to the staple 800, for example, an array of barbs 808 can extend along each of the legs 804 from the base 802 of the staple 800 toward the tips 806 of the legs 804. As illustrated in FIG. 62, the arrays of barbs 808 may not extend to the tips 806 of the legs 804. In various instances, the arrays of barbs 808 can extend along half, or approximately half, the lengths of the legs 804, for example; however, any suitable length of the barb arrays could be utilized. For instance, the arrays of barbs 808 can extend along less than half or more than half of the lengths of the legs 804. In some embodiments, an array of barbs 808 can extend along each of the legs 804 from the tips 806 of the legs 804 toward the base 802. In such embodiments, the array of barbs 808 may not extend to the base 802. In some embodiments, a leg 804 can comprise an array of barbs 808 which does not extend to the tip 806 of the leg 804 or the base 802. In certain embodiments, a leg 804 can comprise more than one array of barbs 808.

[0217] In various instances, further to the above, a staple leg 804 can comprise an array of barbs 809 which extends along the entire length thereof. By way of example, referring to FIG. 64, the legs 804 of the staple 830 each comprise

an array of barbs 809 which extends along the entire length of the legs 804. In some instances, a staple leg 804 can comprise an array of barbs 809 which extends along less than the entire length thereof. By way of example, referring to FIG. 65, the legs 804 of the staple 840 each comprise an array of barbs 809 which extends along less than the entire length of the legs 804. Similarly, referring to FIG. 68, the legs 804 of the staple 870 each comprise an array of barbs 809 which extends along less than the entire length of the legs 804. With regard to the staple 840, for example, an array of barbs 809 can extend along each of the legs 804 from the base 802 of the staple 840 toward the tips 806 of the legs 804. As illustrated in FIG. 65, the arrays of barbs 809 may not extend to the tips 806 of the legs 804. In various instances, the arrays of barbs 809 can extend along half, or approximately half, the lengths of the legs 804, for example; however, any suitable length of the barb arrays could be utilized. For instance, the arrays of barbs 809 can extend along less than half or more than half of the lengths of the legs 804. In some embodiments, an array of barbs 809 can extend along each of the legs 804 from the tips 806 of the legs 804 toward the base 802. In such embodiments, the array of barbs 809 may not extend to the base 802. In some embodiments, as illustrated in FIG. 66, a leg 804 can comprise an array of barbs 809 which does not extend to the tip 806 of the leg 804 or the base 802. In certain embodiments, a leg 804 can comprise more than one array of barbs 809.

[0218] Various barb configurations are depicted in FIGS. 70-73, although any suitable barb configuration could be utilized. Referring to FIG. 70, a staple leg 804 can include at least one barb 809, for example. In various instances, the barb 809 can comprise a prong. The prong can include a first surface 809a and a second surface 809b which can extend from the perimeter 805 of the staple leg 804. The first surface 809a can comprise an inclined surface, a convex surface, and/or a concave surface, for example. The second surface 809b can comprise a flat, or an at least substantially flat, surface, for example. In various instances, the first surface 809a and the second surface 809b can converge at an edge 809c, for example. The barb 809 can be formed utilizing any suitable process. For instance, the barb 809 can be formed utilizing a stamping process. In at least one embodiment, a forming die, for example, can be utilized to strike the perimeter 805 of the wire comprising the leg 804 in order to upset, or disturb, enough material to create the barb 809. In various instances, a barb can comprise any suitable nib or spur, for example. In various embodiments, the barb 809 can be tapered. In various instances, the barb 809 can include a base adjacent to the perimeter 805 which is thicker than a tip of the barb 809.

[0219] Referring now to FIGS. 68, 69, 71, and 71A, a staple leg 804 can include at least one barb 879, for example. In at least one embodiment, the barb 879 can extend around a portion of the perimeter 805 of the staple leg 804. In various instances, the barb 879 can include a first surface 879a and a second surface 879b which can extend from the perimeter 805 of the staple leg 804. The first surface 879a can comprise an inclined surface, a convex surface, and/or a concave surface, for example. The second surface 879b can comprise a flat, or an at least substantially flat, surface, for example. In various instances, the first surface 879a and the second surface 879b can converge at an edge 879c, for example. In various instances, the edge 879c can be arcuate, for example. The barb 879 can be formed utilizing any suitable process. For instance, the barb 879 can be formed utilizing a stamping process. In at least one embodiment, a forming die, for example, can be utilized to strike the perimeter 805 of the wire comprising the leg 804 in order to upset, or disturb, enough material to create the barb 879. Referring primarily to FIG. 71A, the wire comprising the leg 804 can be defined by a diameter 801 and the barb 879 can be defined by a diameter which is

larger than the diameter 801. Correspondingly, the wire comprising the leg 804 can be defined by a radius and the barb 879 can be defined by a radius which is larger than the wire radius. In various embodiments, the barb 879 can be tapered. In various instances, the barb 879 can include a base adjacent to the perimeter 805 which is thicker than a tip of the barb 879.

[0220] Referring now to FIG. 72, a staple leg 804 can include at least one barb 889, for example. In at least one embodiment, the barb 889 can extend around the entirety of the perimeter 805 of the staple leg 804. In various instances, the barb 889 can include a first surface 889a and a second surface 889b which can extend from the perimeter 805 of the staple leg 804. The first surface 889a can comprise an inclined surface, a convex surface, and/or a concave surface, for example. The second surface 889b can comprise a flat, or an at least substantially flat, surface, for example. In various instances, the first surface 889a and the second surface 889b can converge at an edge 889c, for example. In various instances, the edge 889c can be arcuate, for example. The barb 889 can be formed utilizing any suitable process. For instance, the barb 889 can be formed utilizing a stamping process. In at least one embodiment, a forming die, for example, can be utilized to strike the perimeter 805 of the wire comprising the leg 804 in order to upset, or disturb, enough material to create the barb 889. The wire comprising the leg 804 can be defined by a wire diameter and the barb 889 can be defined by a diameter which is larger than the wire diameter. Correspondingly, the wire comprising the leg 804 can be defined by a radius and the barb 889 can be defined by a radius which is larger than the wire radius. In various embodiments, the barb 889 can be tapered. In various instances, the barb 889 can include a base adjacent to the perimeter 805 which is thicker than a tip of the barb 889.

[0221] Referring now to FIG. 73, a staple leg 804 can include at least one barb 899, for example. In various instances, the barb 899 can comprise a prong. The prong can include a first surface 899a and a second surface 899b which can extend from the perimeter of the staple leg 804. The first surface 899a can comprise an inclined surface, a convex surface, and/or a concave surface, for example. The second surface 899b can comprise a flat, or an at least substantially flat, surface, for example. In various instances, the first surface 899a and the second surface 899b can converge at an edge 899c, for example. The barb 899 can be formed utilizing any suitable process. For instance, the barb 899 can be formed utilizing a stamping process. In at least one embodiment, a forming die, for example, can be utilized to strike the perimeter of the wire comprising the leg 804 in order to upset, or disturb, enough material to create the barb 899. In various embodiments, the wire comprising the staple can include one or more flat sides. In at least one embodiment, the wire can include opposing flat sides 895, for example. In at least one such embodiment, the flat sides 895 can be formed into a cylindrical wire. In some instances, the wire can retain one or more cylindrical surfaces in addition to the flat sides 895. In various instances, a barb can comprise any suitable nib or spur, for example. In various embodiments, the barb 899 can be tapered. In various instances, the barb 899 can include a base adjacent to the perimeter of the leg 804 which is thicker than a tip of the barb 899.

[0222] In various instances, the legs of a staple can define a staple plane. The base of the staple may or may not be positioned within the staple plane. In either event, one or more barbs extending from the legs and/or the base may extend within and/or extend parallel with respect to the staple plane. In some instances, one or more barbs extending from the legs and/or the base can extend outwardly from the staple plane. One or more barbs extending from the legs and/or the base can extend transversely with respect to the staple plane. In various instances, a barb can extend

circumferentially around a staple leg. Such a barb can extend within and outwardly from the staple plane. In some instances, a barb can extend around the entire circumference of a staple leg. In certain instances, the barb can extend less than 360 degrees around a staple leg. A barb extending within a staple plane can readily control tissue within the staple plane. A barb extending outwardly from a staple plane can readily control tissue outside of the staple plane. A staple, and/or a staple leg, can include one or more barbs extending within the staple plane and one or more barbs extending outwardly from the staple plane.

[0223] Referring again to FIG. 62, the barbs extending from a staple leg 804 can be configured to retain the staple leg 804 within tissue. As outline above, the staple legs 804 may be malformed and/or unformed by an anvil in certain instances and, owing to the barb, or barbs, extending therefrom, the staple leg 804 may still be retained in the tissue. In various instances, the barbs can be configured to trap tissue within the tissue entrapment area of the staple. In certain instances, the barbs can be configured to hold the tissue against the base 802. In such instances, the barbs can apply a compressive force or pressure to the tissue. As discussed above in connection with the embodiments depicted in FIGS. 70-73, a barb can comprise an inclined, convex, and/or concave top surface, such as surfaces 809a, 879a, 889a, and/or 899a, for example. The top surfaces of the barbs can be configured to facilitate the insertion of the barbs and the staple legs 804 into and/or through the tissue. As also discussed above in connection with the embodiments depicted in FIGS. 70-73, a barb can comprise a flat, or at least substantially flat, bottom surface, such as surfaces 809b, 879b, 889b, and/or 899b, for example. The bottom surfaces of the barbs can be configured to inhibit the removal of the barbs and the staple legs 804 from the tissue. As a result of the above, in certain circumstances, the top surfaces of the barbs can be configured to pierce the tissue while the bottom surfaces of the barbs can be configured to abut the tissue. In various circumstances, the tips 806 of the staple legs 804 can be configured to puncture a hole in the tissue while the staple legs 804 and the barbs extending therefrom can be configured to resiliently expand the hole such that the tissue can flow around the barbs as the staple legs 804 are being pushed through the tissue and flow back underneath the bottom surfaces of the barbs.

[0224] In certain embodiments, a first barb can extend from a first leg 804 of the staple and a second barb can extend from a second leg 804 of the staple. In various instances, the first barb and the second barb can be located the same, or at least substantially the same, distance between from the base 802. In certain instances, the first barb and the second barb can be located the same, or at least substantially the same, vertical distance from the base 802. As discussed above, a staple leg 804 can include an array of barbs extending along the length of the staple leg 804. In various embodiments, referring primarily to FIG. 62, a staple can include a first leg 804 including a first array of barbs and a second leg 804 including a second array of barbs wherein the first array of barbs and the second array of barbs can be configured to co-operatively hold the staple within the tissue. In various embodiments, a barb from the first array and a barb from the second array can comprise a pair of barbs configured to engage tissue at the same vertical distance from the base 802, for example. In various instances, a staple can comprise more than one pair of barbs. In certain instances, each of the barb pairs can be configured to engage the tissue at a different vertical distance from the base 802. In such circumstances, a staple can be suitable for use with different tissue thicknesses. For instance, when a staple is used to staple thin tissue, one pair of barbs, or less than all of the barb pairs, may engage the thin tissue. If that staple were used to staple thick tissue, however, additional barb pairs, or all of the barb pairs, may engage the

tissue. In certain embodiments, the barbs extending from the legs 804 can be arranged in a manner in accordance with the tissue thickness, or range of tissue thicknesses, that can be stapled by the staple. For instance, referring again to FIG. 62, the barbs 808 and 809 can be selectively positioned along the legs 804 such that they are positioned within and/or adjacent to the tissue captured within the staple. In certain instances, the portions of the staple legs 804 that are deformed by, or come into contact with, an anvil may not include barbs extending therefrom. In at least some instances, an array of barbs extending from the inwardly-facing side of the staple legs 804 may be longer than an array of barbs extending from the outwardly-facing side of the staple legs 804. In other instances, an array of barbs extending from the inwardly-facing side of the staple legs 804 may be shorter than an array of barbs extending from the outwardly-facing side of the staple legs 804. In yet other instances, an array of barbs extending from the inwardly-facing side of the staple legs 804 may be the same length as an array of barbs extending from the outwardly-facing side of the staple legs 804.

[0225] As discussed above, the barbs extending from the staple legs 804 can assist in retaining the staple within the tissue if the staple legs 804 are malformed and/or unintentionally unformed. Certain circumstances are contemplated, however, where a staple including one or more of the barbs disclosed herein is inserted into tissue and remains intentionally unformed. In any event, staples including one or more of the barbs disclosed herein can be useful in stapling thick tissue. More particularly, in some instances, the presence of thick and/or dense tissue between a staple cartridge and an anvil and/or the presence of thick and/or dense tissue within a staple may prevent the staple from becoming fully formed or closed. For instance, the staple may not be fully closed into a B-form configuration or the staple may not be closed at all. In such instances, the barbs of the unclosed staples may inhibit or prevent the tissue from being pulled out of the staple, for example. An array of barbs extending along the length of a staple leg may permit the leg to remain retained in the tissue regardless of the thickness of the tissue.

[0226] Various embodiments are contemplated in which at least one barbed staple, such as barbed staple 800, for example, are removably stored within a staple cartridge, such as the staple cartridge 22000 illustrated in FIGS. 10-12, for example. Certain embodiments are envisioned in which a staple cartridge includes only barbed staples while other embodiments are envisioned which utilize barbed staples and non-barbed staples. For instance, a first row of staples can comprise barbed staples while a second row of staples can comprise non-barbed staples. In some instances, the staples stored within a staple cartridge can have the same, or essentially the same, unformed height. At least with regard to U-shaped and/or V-shaped staples, for example, the unformed height of a staple can be defined as the vertical distance between the bottom of the base of the staple and the tips of the staple legs. Such a measurement can be taken before the staples are inserted into the staple cartridge, when the staples are removably stored within the staple cartridge, and/or before the staples are deformed against the anvil. In some instances, barbed staples arranged in a first row in a staple cartridge can comprise a first unformed height and barbed staples arranged in a second row in the staple cartridge can comprise a second unformed height. Barbed staples in a third row in the staple cartridge can comprise the first unformed height, the second unformed height, or a third unformed height. The first row, the second row, and/or the third row of barbed staples can be positioned on the same side of a knife slot defined in the staple cartridge or on opposite sides of the knife slot. In use, the barbed staples removably stored in a staple cartridge can be formed to the same formed height or different formed heights. The formed height of a staple can be defined as the

overall vertical distance of the staple after it has been deformed against an anvil. At least with regard to a staple that has been deformed into a B-form, for example, the formed height of the staple can be measured between the bottom of the base of the staple and the top-most portion of the staple legs. In some instances, barbed staples arranged in a first row in a staple cartridge can be deformed to a first formed height and barbed staples arranged in a second row in the staple cartridge can be deformed to a second formed height. Barbed staples in a third row in the staple cartridge can comprise the first formed height, the second formed height, or a third formed height. The first row, the second row, and/or the third row of barbed staples can be positioned on the same side of a knife slot defined in the staple cartridge or on opposite sides of the staple cartridge. As the reader will appreciate, the staples depicted in FIGS. 10-12 have been deformed to different formed heights. Barbed staples 800, for example, could be utilized in staple cartridges and/or stapling instruments which create staple rows having different formed heights. A first row of barbed staples 800 could be deformed to a first formed height and a second row of barbed staples 800 could be deformed to a second formed height. In various instances, a third row of barbed staples 800 could be deformed to a third formed height. In some instances, the barbed staples 800 deformed to different heights can begin with the same, or essentially the same, unformed height. In certain instances, the barbed staples 800 deformed to different formed heights can begin with different unformed heights. Various structures can be utilized to form staples to different formed heights. For instance, movable drivers supporting the staples can support the staples at different distances relative to the anvil. In some instances, the anvil can include staple forming pockets having different depths. In various instances, a staple driver can include a cradle configured to support the base of a staple and push the staple upwardly toward a forming pocket defined in the anvil. The formed height of a staple can be determined by the distance between the bottom surface of the cradle and the top surface of the forming pocket. U.S. Patent No. 8,317,070, entitled SURGICAL STAPLING DEVICES THAT PRODUCE FORMED STAPLES HAVING DIFFERENT LENGTHS, issued on November 27, 2012, is incorporated by reference in its entirety. In certain instances, the deck of a staple cartridge can include stepped surfaces, as illustrated in FIG. 1. A first row of staple cavities can be defined in a first step and a second row of staple cavities can be defined in a second step wherein the first step and the second step can be vertically offset from one another. For instance, the first step can be positioned vertically above, or closer to, the anvil than the second step. In certain instances, a wall can be defined between the first step and the second step. In some instances, the deck of a staple cartridge can comprise a first step, a second step positioned vertically above the first step, and a third step positioned vertically above the second step. Various embodiments are envisioned in which the deck of a staple cartridge includes any suitable number of steps and any suitable number of walls between the steps. A first row of staple cavities can be defined in the first step, a second row of staple cavities can be defined in the second step, and/or a third row of staple cavities can be defined in the third step, for example. The first row of staple cavities can include staples having a first unformed height, the second row of staple cavities can include staples having a second unformed height, and/or the third row of staple cavities can include staples having a third unformed height, for example. Various embodiments are envisioned in which a staple cartridge includes any suitable number of staple rows having different unformed heights. The staples in the first row of staple cavities can be deformed to a first formed height, the staples in the second row of staple cavities can be deformed to a second formed height, and/or the third row of staple cavities can be deformed to a third formed height, for example. Various embodiments are

envisioned in which a staple cartridge includes any suitable number of staple rows which are deformed to different formed heights. In addition to or in lieu of having different formed staple heights, an end effector of a stapling instrument can have different tissue gaps. For instance, referring generally to FIGS. 10 and 11, a gap can be defined between the cartridge deck surface 22011 of a staple cartridge and the anvil tissue compression surface 10063 of an anvil. This gap can be configured to receive tissue T. This gap can also be configured to receive a tissue thickness compensator; however, a barbed staple may or may not be used with a tissue thickness compensator and the discussion provided with respect to barbed staples can be applicable in either circumstance. In any event, the reader will appreciate that the anvil tissue compression surface 10063 is stepped. The anvil tissue compression surface 10063 comprises a first portion positioned vertically above a second portion. When the anvil and the staple cartridge of an end effector are in a closed condition, as illustrated in FIG. 11, a first gap distance is defined between an outer portion of the anvil tissue compression surface 10063 and the cartridge deck surface 22011 and a second, different, gap distance is defined between an inner portion of the anvil tissue compression surface 10063 and the cartridge deck surface 22011. The first gap distance is illustrated as being larger than the second gap distance, but it is possible for the first gap distance to be shorter than the second gap distance. Tissue compressed between the anvil and the staple cartridge in the shorter gap distance can be compressed more than tissue in the larger gap distance. The barbs of a barbed staple 800, for example, may engage the tissue differently depending on whether the tissue is positioned within a shorter tissue gap or a larger tissue gap. More particularly, tissue compressed within a shorter tissue gap may seek to re-expand more after it is released from an end effector than tissue compressed within a larger tissue gap and the barbs of a barbed staple may inhibit or resist this re-expansion, depending on their configuration and/or position on the barbs. In other instances, the barbs may be configured and/or positioned so as to not inhibit or resist the re-expansion of the tissue. As the reader will appreciate, anvil tissue compression surface 10063 is stepped and the cartridge deck surface is flat, or at least substantially flat, and, thus, the difference in tissue gaps defined within the end effector is a function of the height of the stepped anvil surfaces. Other embodiments are envisioned. For instance, the anvil tissue compression surface can be flat, or at least substantially flat, and the cartridge deck surface can be stepped. In other instances, the anvil tissue compression surface and the cartridge deck surface can both be stepped. In any event, different gap distances can be defined between the anvil tissue compression surface and the cartridge deck surface. While two gap distances have been illustrated in FIGS. 10 and 11, more than two gap distances may be possible, such as three gap distances, for example. With further reference to FIGS. 10 and 11, a first longitudinal row of forming pockets can be arranged within a first portion of an end effector having first tissue gap distance and a second longitudinal row of forming pockets can be arranged within a second portion of the end effector having a second tissue gap distance which is different than the first tissue gap distance. In some instances, the end effector can include a third longitudinal row of forming pockets arranged within a third portion of the end effector having a third tissue gap distance which is different than the first tissue gap distance and the second tissue gap distance. In certain instances, the end effector can include a third longitudinal row of forming pockets arranged within a third portion of the end effector having a tissue gap distance which is the same as the first tissue gap distance or the second tissue gap distance. The reader will appreciate that an end effector can have different tissue gap distances and/or different formed staple heights. An end effector can have one, the other, or both. In certain instances, shorter formed staple

heights can be associated within shorter tissue gap distances while larger formed staple heights can be associated with larger tissue gap distances. In other instances, shorter formed staple heights can be associated with larger tissue gap distances while larger formed staple heights can be associated with shorter tissue gap distances. Further to the above, a staple can include a U-shape configuration in its unformed state. A U-shape staple can comprise a base and two staple legs extending from the base wherein the staple legs extend in parallel directions to each other. Also further to the above, a staple can include a V-shape configuration in its unformed state. A V-shape configuration can comprise a base and two staple legs extending from the base wherein the staple legs extend in directions which are not parallel.

[0227] Various embodiments described herein are described in the context of linear end effectors and/or linear fastener cartridges. Such embodiments, and the teachings thereof, can be applied to non-linear end effectors and/or non-linear fastener cartridges, such as, for example, circular and/or contoured end effectors. For example, various end effectors, including non-linear end effectors, are disclosed in U.S. Patent Application Serial No. 13/036,647, filed February 28, 2011, entitled SURGICAL STAPLING INSTRUMENT, now U.S. Patent Application Publication No. 2011/0226837, which is hereby incorporated by reference in its entirety. Additionally, U.S. Patent Application Serial No. 12/893,461, filed September 29, 2012, entitled STAPLE CARTRIDGE, now U.S. Patent Application Publication No. 2012/0074198, is hereby incorporated by reference in its entirety. U.S. Patent Application Serial No. 12/031,873, filed February 15, 2008, entitled END EFFECTORS FOR A SURGICAL CUTTING AND STAPLING INSTRUMENT, now U.S. Patent No. 7,980,443, is also hereby incorporated by reference in its entirety. The entire disclosure of U.S. Patent No. 7,845,537, entitled SURGICAL INSTRUMENT HAVING RECORDING CAPABILITIES, which issued on December 7, 2010, is incorporated by reference herein. The entire disclosure of U.S. Application Serial No. 13/118,241, entitled SURGICAL STAPLING INSTRUMENTS WITH ROTATABLE STAPLE DEPLOYMENT ARRANGEMENTS, now U.S. Patent Application Publication No. 2012/0298719, which was filed on May 27, 2011, is incorporated by reference herein.

[0228] The devices disclosed herein can be designed to be disposed of after a single use, or they can be designed to be used multiple times. In either case, however, the device can be reconditioned for reuse after at least one use. Reconditioning can include any combination of the steps of disassembly of the device, followed by cleaning or replacement of particular pieces, and subsequent reassembly. In particular, the device can be disassembled, and any number of the particular pieces or parts of the device can be selectively replaced or removed in any combination. Upon cleaning and/or replacement of particular parts, the device can be reassembled for subsequent use either at a reconditioning facility, or by a surgical team immediately prior to a surgical procedure. Those skilled in the art will appreciate that reconditioning of a device can utilize a variety of techniques for disassembly, cleaning/replacement, and reassembly. Use of such techniques, and the resulting reconditioned device, are all within the scope of the present application.

[0229] Preferably, the invention described herein will be processed before surgery. First, a new or used instrument is obtained and if necessary cleaned. The instrument can then be sterilized. In one sterilization technique, the instrument is placed in a closed and sealed container, such as a plastic or TYVEK bag. The container and instrument are then placed in a field of radiation that can penetrate the container, such as gamma radiation, x-rays, or high-energy electrons. The radiation kills bacteria on the instrument and in the container. The sterilized instrument can then be

stored in the sterile container. The sealed container keeps the instrument sterile until it is opened in the medical facility.

[0230] Any patent, publication, or other disclosure material, in whole or in part, that is said to be incorporated by reference herein is incorporated herein only to the extent that the incorporated materials does not conflict with existing definitions, statements, or other disclosure material set forth in this disclosure. As such, and to the extent necessary, the disclosure as explicitly set forth herein supersedes any conflicting material incorporated herein by reference. Any material, or portion thereof, that is said to be incorporated by reference herein, but which conflicts with existing definitions, statements, or other disclosure material set forth herein will only be incorporated to the extent that no conflict arises between that incorporated material and the existing disclosure material.

[0231] While this invention has been described as having exemplary designs, the present invention may be further modified within the spirit and scope of the disclosure. This application is therefore intended to cover any variations, uses, or adaptations of the invention using its general principles. Further, this application is intended to cover such departures from the present disclosure as come within known or customary practice in the art to which this invention pertains.

WHAT IS CLAIMED IS:

1. A method for altering a tissue thickness compensator, said method comprising the steps of:
 - obtaining a tissue thickness compensator comprising a surface, wherein said surface is comprised at least partially from a material with a glass transition temperature and a melting temperature;
 - heating said surface to a temperature higher than said glass transition temperature and lower than said melting temperature;
 - manipulating said surface;
 - allowing said manipulated surface to cool below said glass transition temperature; and
 - releasing said surface.
2. The method of Claim 1, wherein said step of obtaining said tissue thickness compensator comprises the steps of:
 - obtaining a biocompatible polymer comprising a glass transition temperature and a melting temperature;
 - dissolving said biocompatible polymer in a solvent to produce a solution; and
 - lyophilizing said solution.
3. The method of Claim 1, wherein said step of manipulating said surface comprises applying at least one compressive force to said surface.
4. The method of Claim 1, wherein said step of manipulating said surface comprises applying at least one tensile force to said surface.
5. The method of Claim 1, further comprising the step of actively cooling said manipulated surface below said glass transition temperature.
6. A customized tissue thickness compensator for use with a surgical stapler, wherein said customized tissue thickness compensator is prepared by a process comprising the steps of:
 - obtaining a tissue thickness compensator comprising a melting temperature;
 - obtaining a surface modifier comprising a contacting surface;
 - heating said contacting surface to a temperature at least equal said melting temperature of said tissue thickness compensator;
 - engaging a surface of said tissue thickness compensator with said heated contacting surface; and
 - removing said surface modifier.
7. The customized tissue thickness compensator of Claim 6, wherein said step of obtaining said tissue thickness compensator comprises the steps of:
 - obtaining a biocompatible polymer comprising a glass transition temperature and a melting temperature;

dissolving said biocompatible polymer in a solvent to produce a solution; and lyophilizing said solution.

8. The customized tissue thickness compensator of Claim 6, wherein said step of engaging said surface of said tissue thickness compensator comprises applying at least one compressive force to said surface.
9. The customized tissue thickness compensator of Claim 6, wherein said process further comprises maintaining said engagement between said surface of said tissue thickness compensator and said heated contacting surface of said surface modifier for a time period sufficient to melt said surface.
10. The customized tissue thickness compensator of Claim 6, wherein said process further comprises the step of actively cooling said tissue thickness compensator.
11. The customized tissue thickness compensator of Claim 6, wherein said surface modifier comprises a heating element configured to heat said contacting surface.
12. A method for producing a biocompatible foam for use with a surgical stapler, said method comprising the steps of:
 - obtaining a biocompatible polymer comprising a glass transition temperature and a melting temperature;
 - dissolving said biocompatible polymer in a solvent to produce a solution;
 - lyophilizing said solution to produce a biocompatible foam;
 - heating said biocompatible foam to a temperature higher than said glass transition temperature and lower than said melting temperature;
 - inserting a space creator into said biocompatible foam;
 - allowing said biocompatible foam to cool below said glass transition temperature; and
 - removing said space creator.
13. The method of Claim 12, wherein said space creator comprises a central beam insertable into said biocompatible foam.
14. The method of Claim 12, wherein said space creator comprises a plurality of protrusions insertable into said biocompatible foam.
15. The method of Claim 14, wherein said plurality of protrusions is arranged in rows.

16. The method of Claim 14, wherein said plurality of protrusions comprises a plurality of pins, wherein said space creator comprises a surface, and wherein each of said plurality of pins extends from said surface in parallel to each other.
17. The method of Claim 16, wherein said each of said plurality of pins extends from said surface along an axis that is perpendicular to said surface.
18. The method of Claim 12, further comprising the step of actively cooling said biocompatible foam to return below said glass transition temperature.
19. A method for altering a biocompatible foam, said method comprising the steps of:
obtaining a biocompatible foam comprising a melting temperature;
heating a space creator to a temperature at least equal to said melting temperature of said biocompatible foam;
inserting said space creator into said biocompatible foam;
allowing said biocompatible foam to cool below said melting temperature; and
removing said space creator.
20. The method of Claim 19, wherein said space creator comprises a central beam insertable into said biocompatible foam.
21. The method of Claim 19, wherein said space creator comprises a plurality of protrusions insertable into said biocompatible foam.

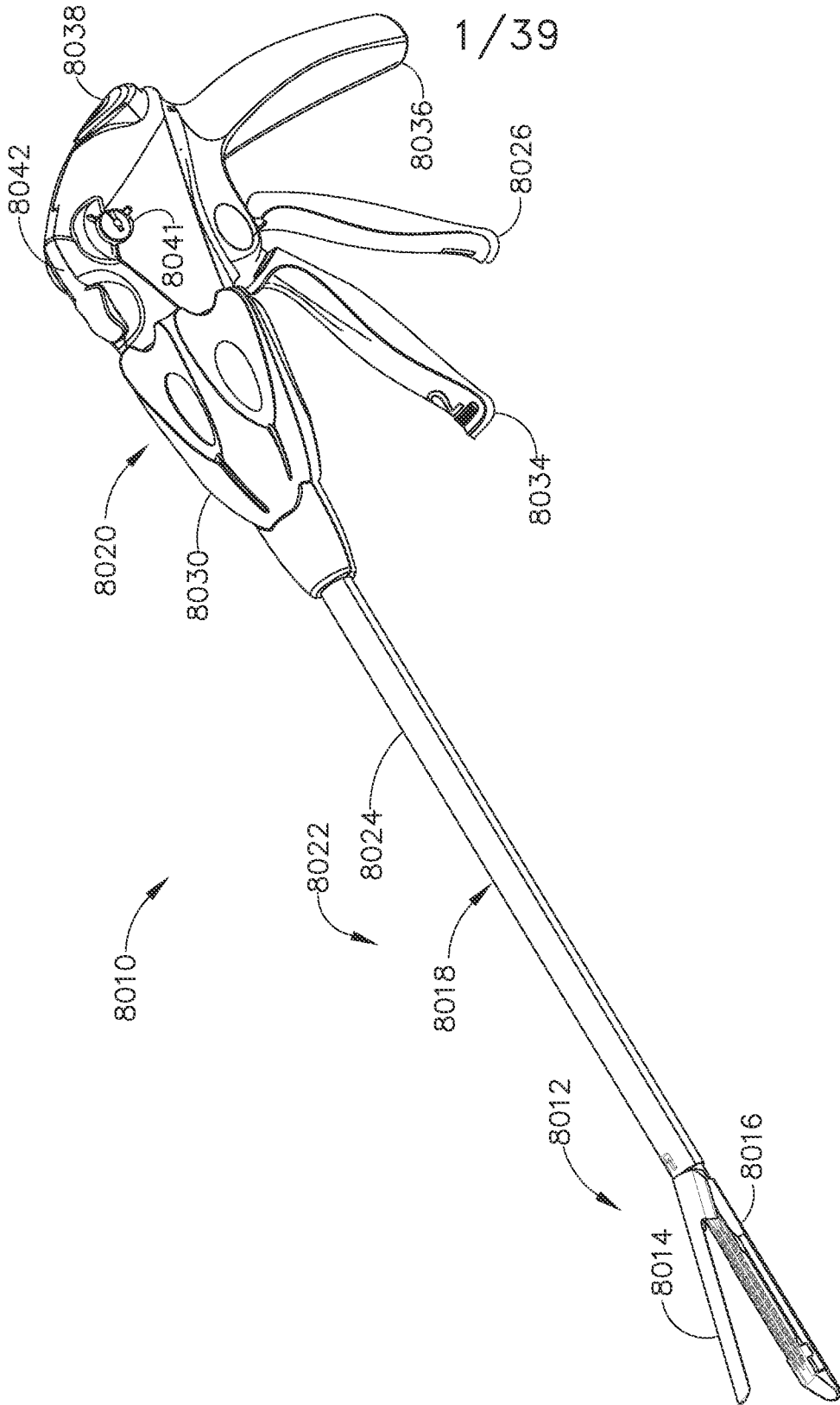

FIG. 1

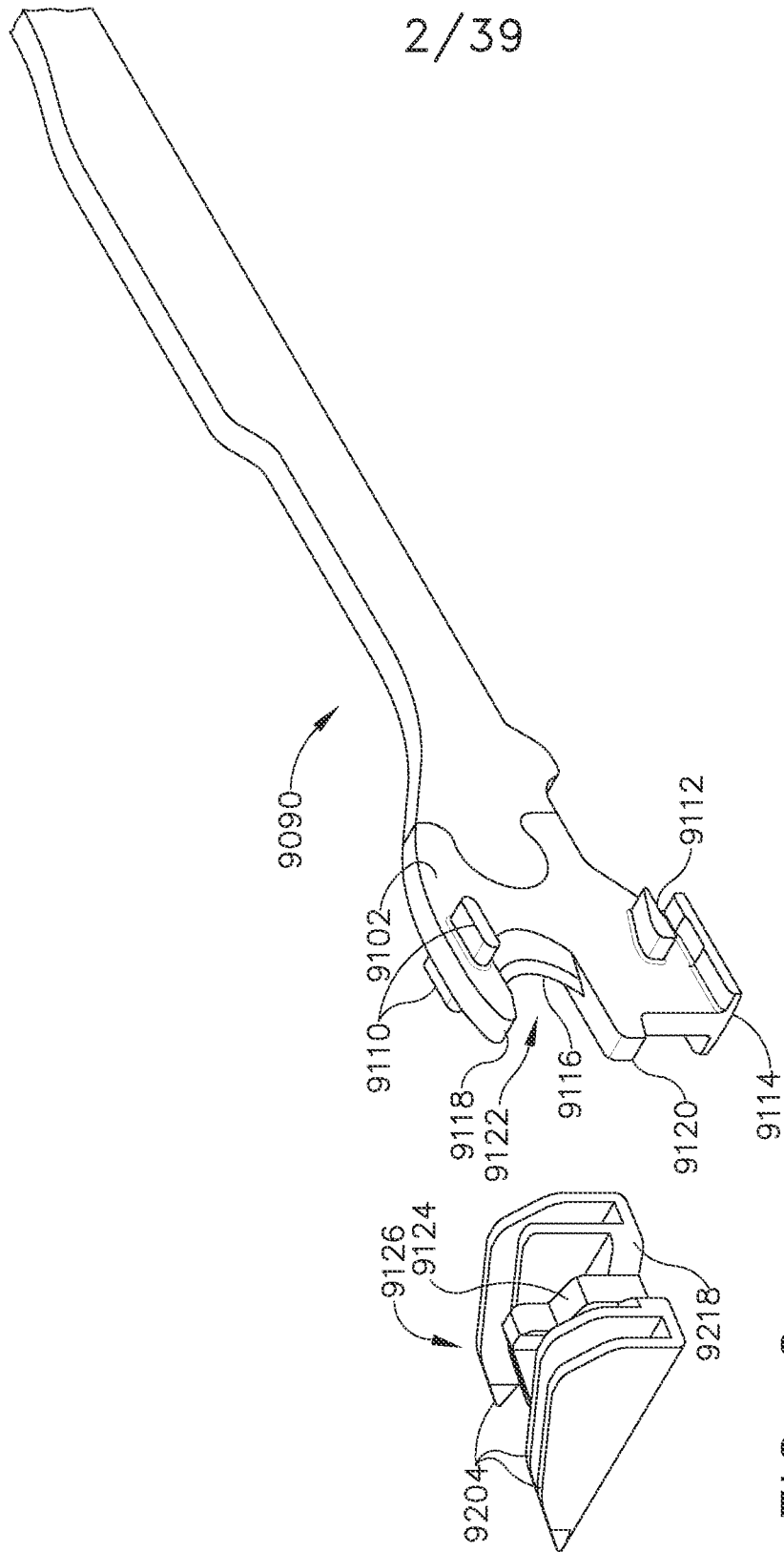

FIG. 3

FIG. 2

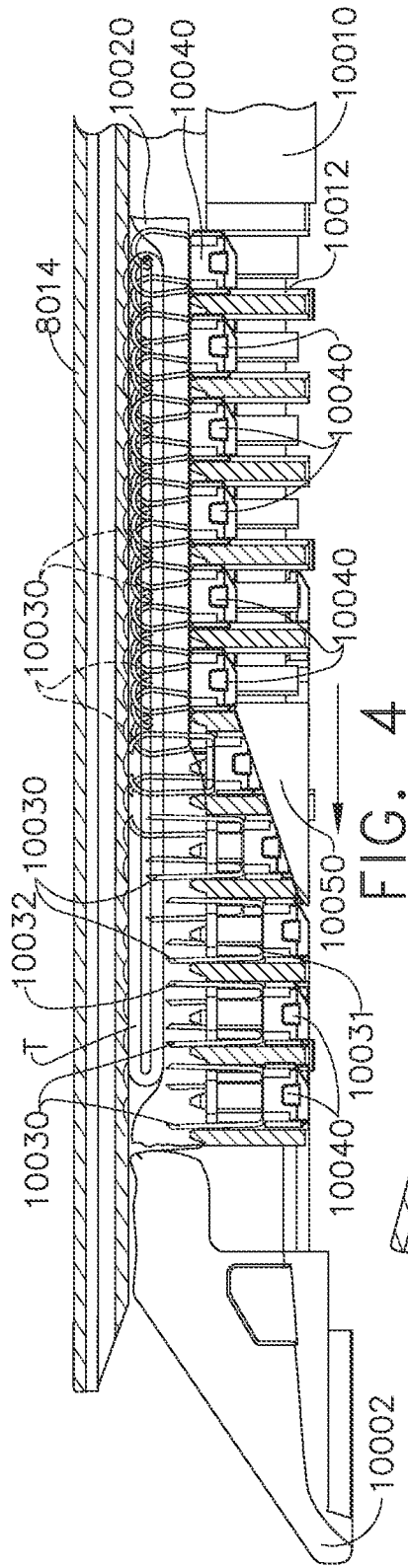

FIG. 4

3/39

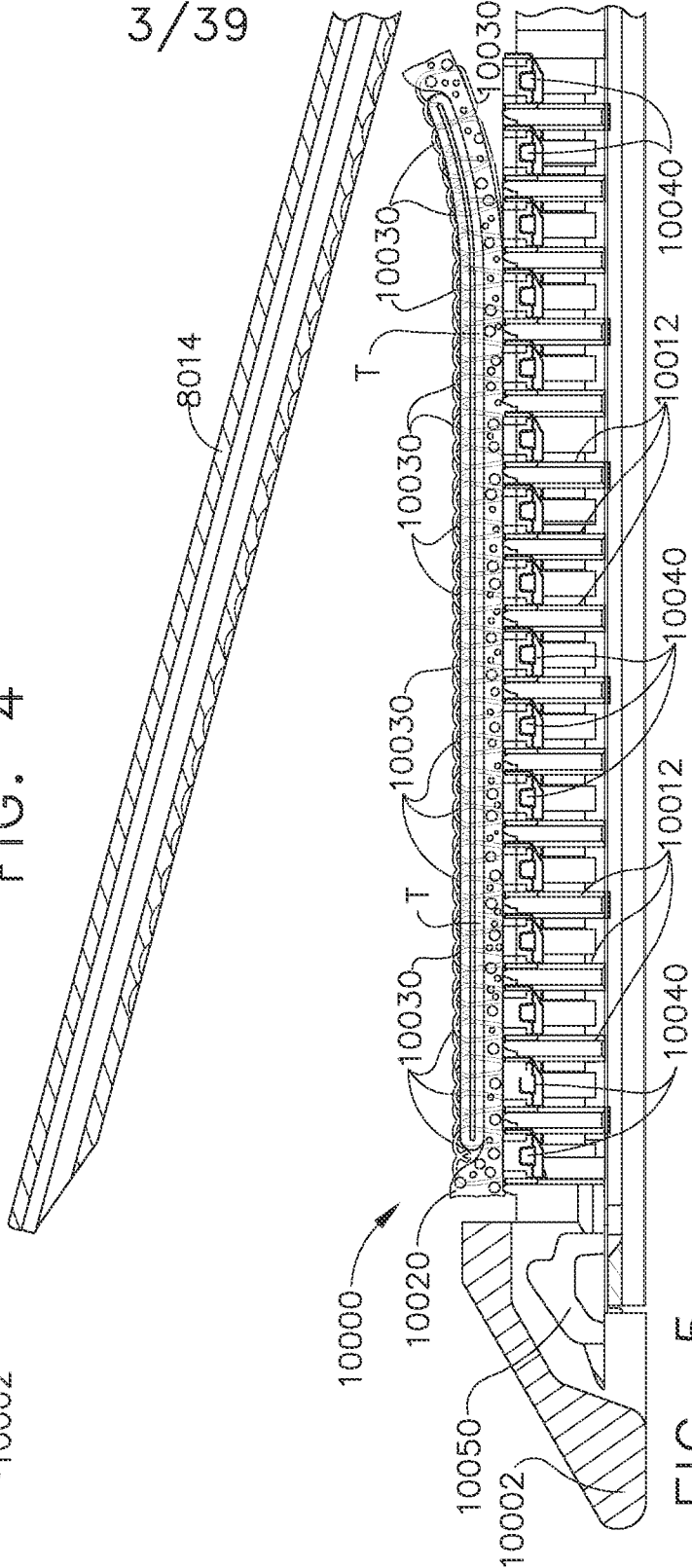

FIG. 5

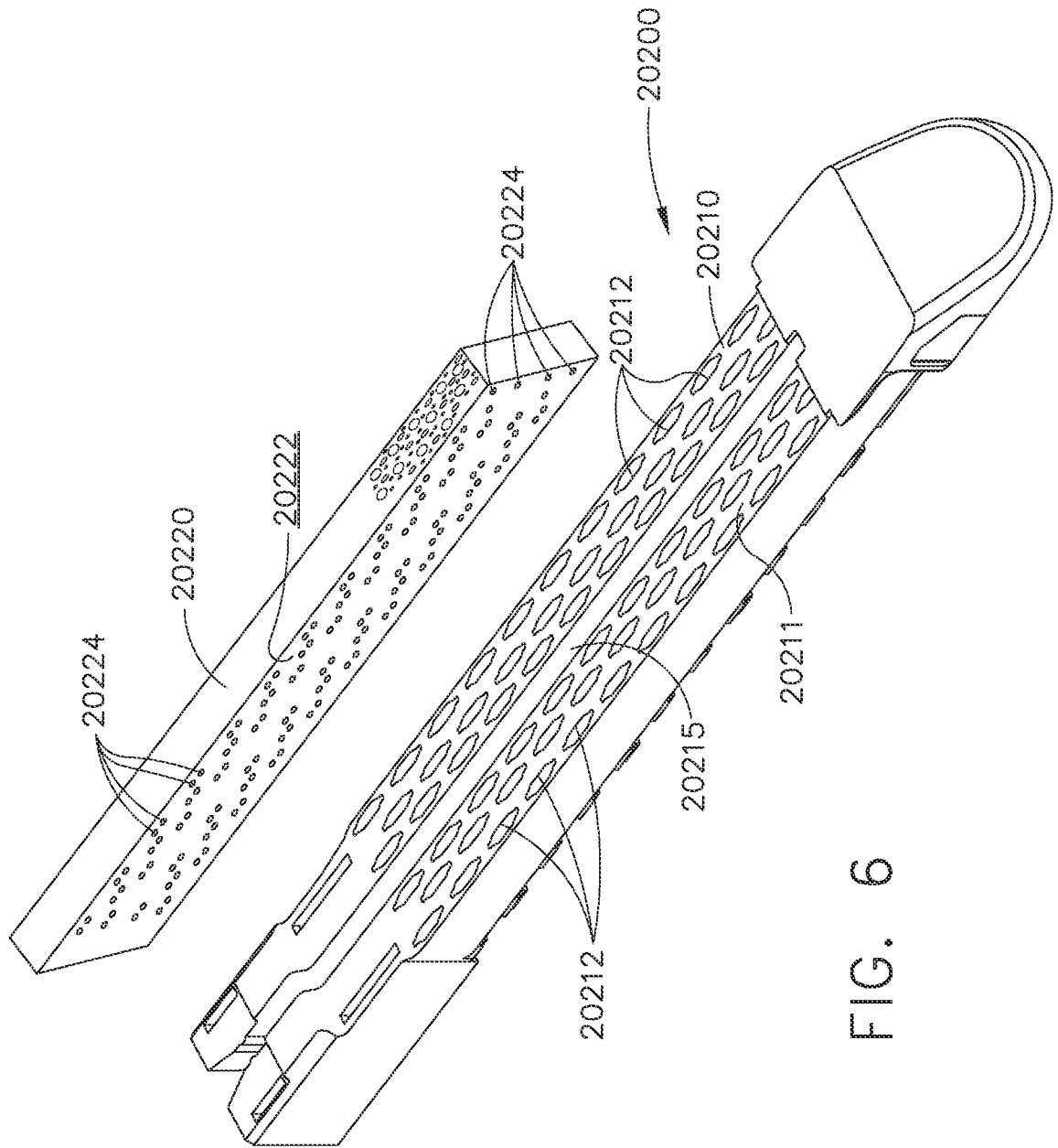

FIG. 6

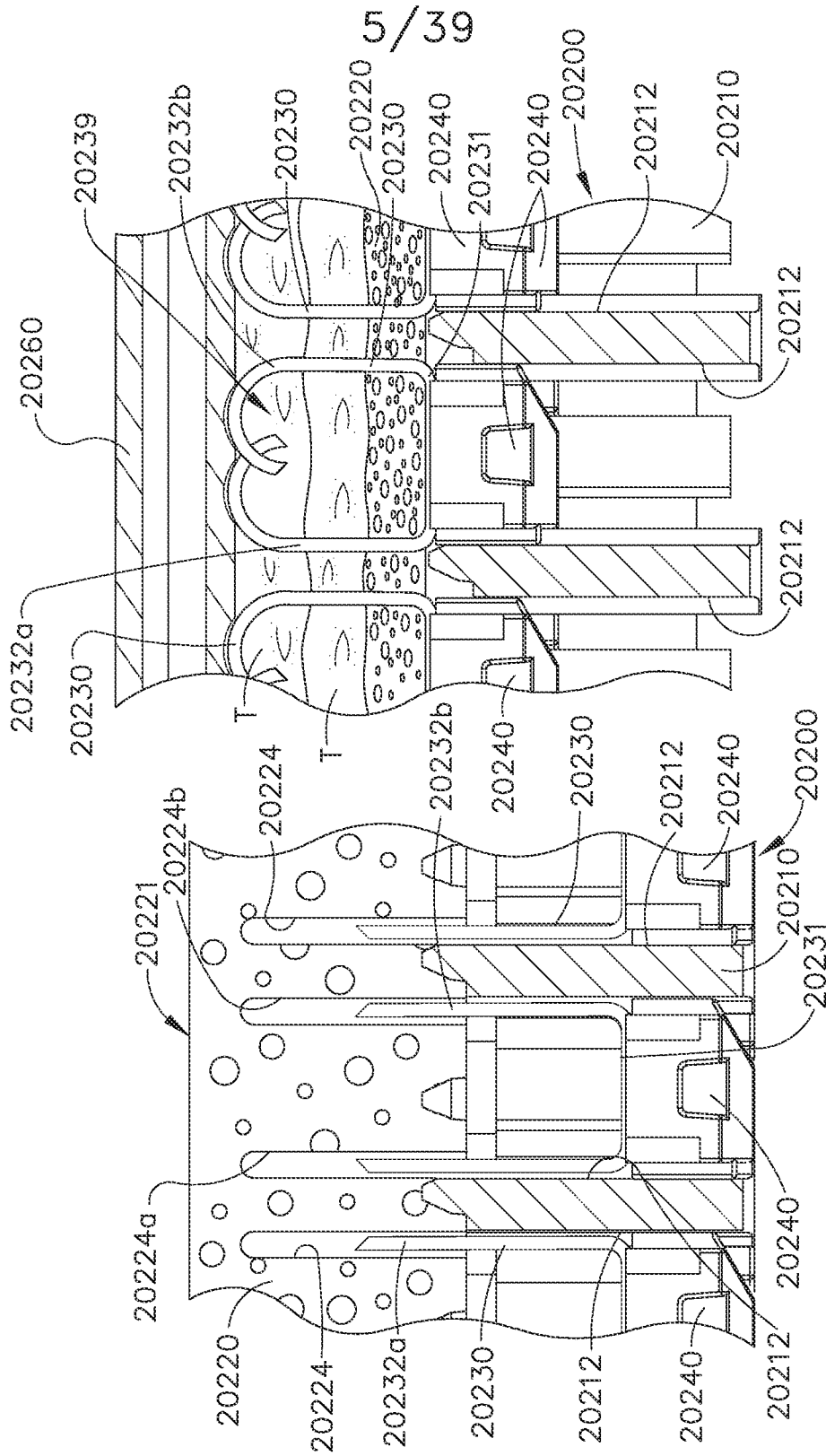

FIG. 8

FIG. 7

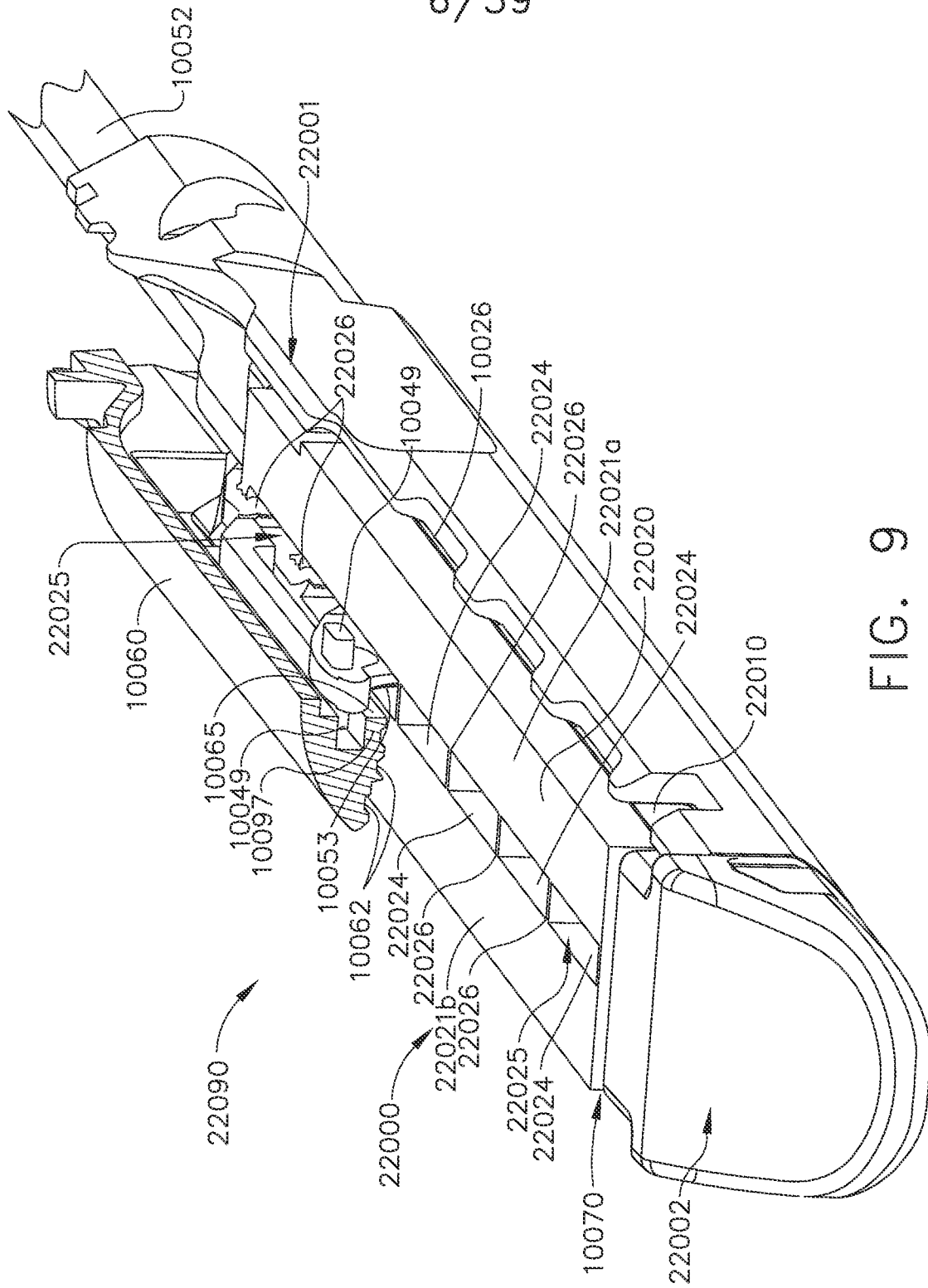

FIG. 9

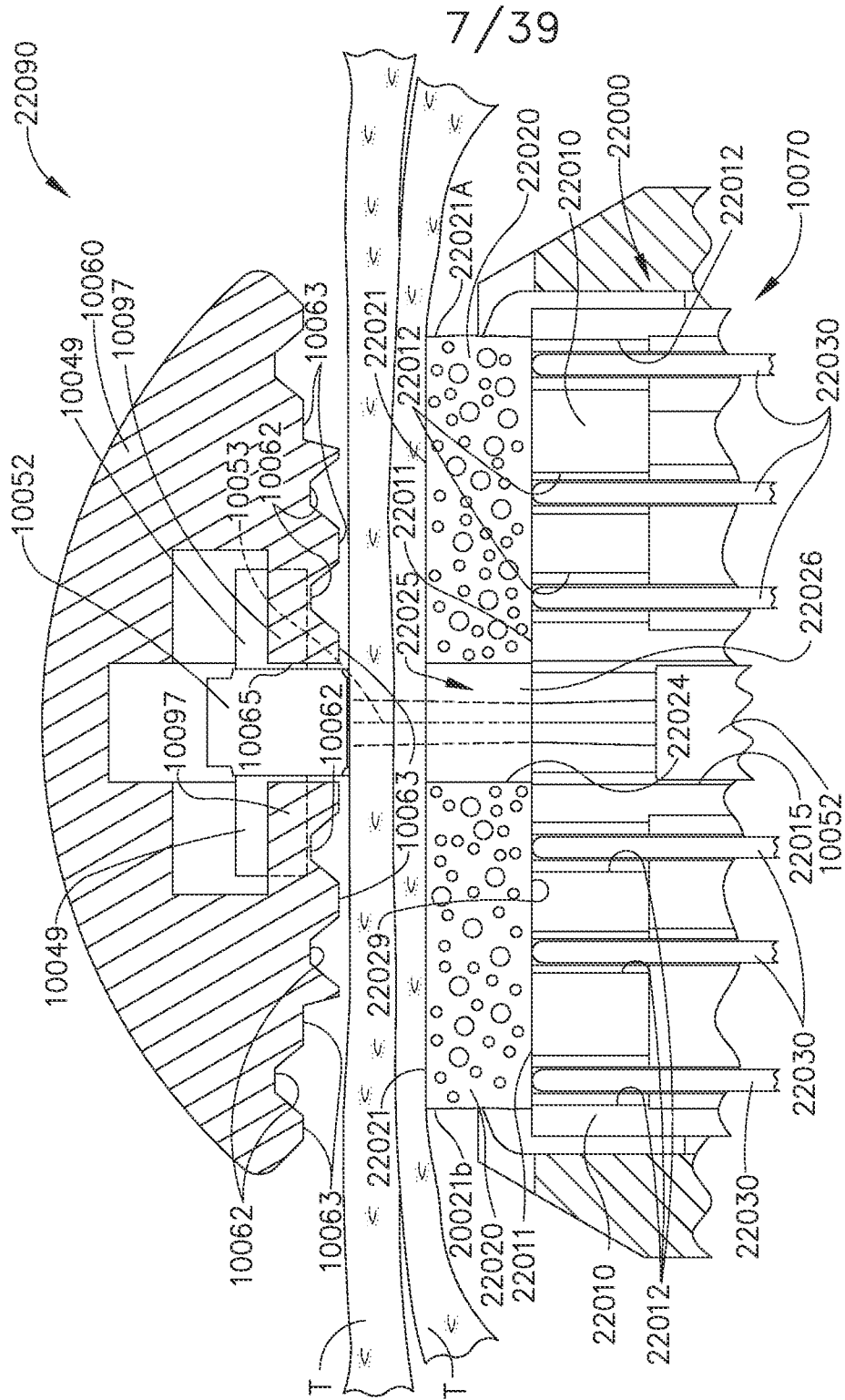

FIG. 10

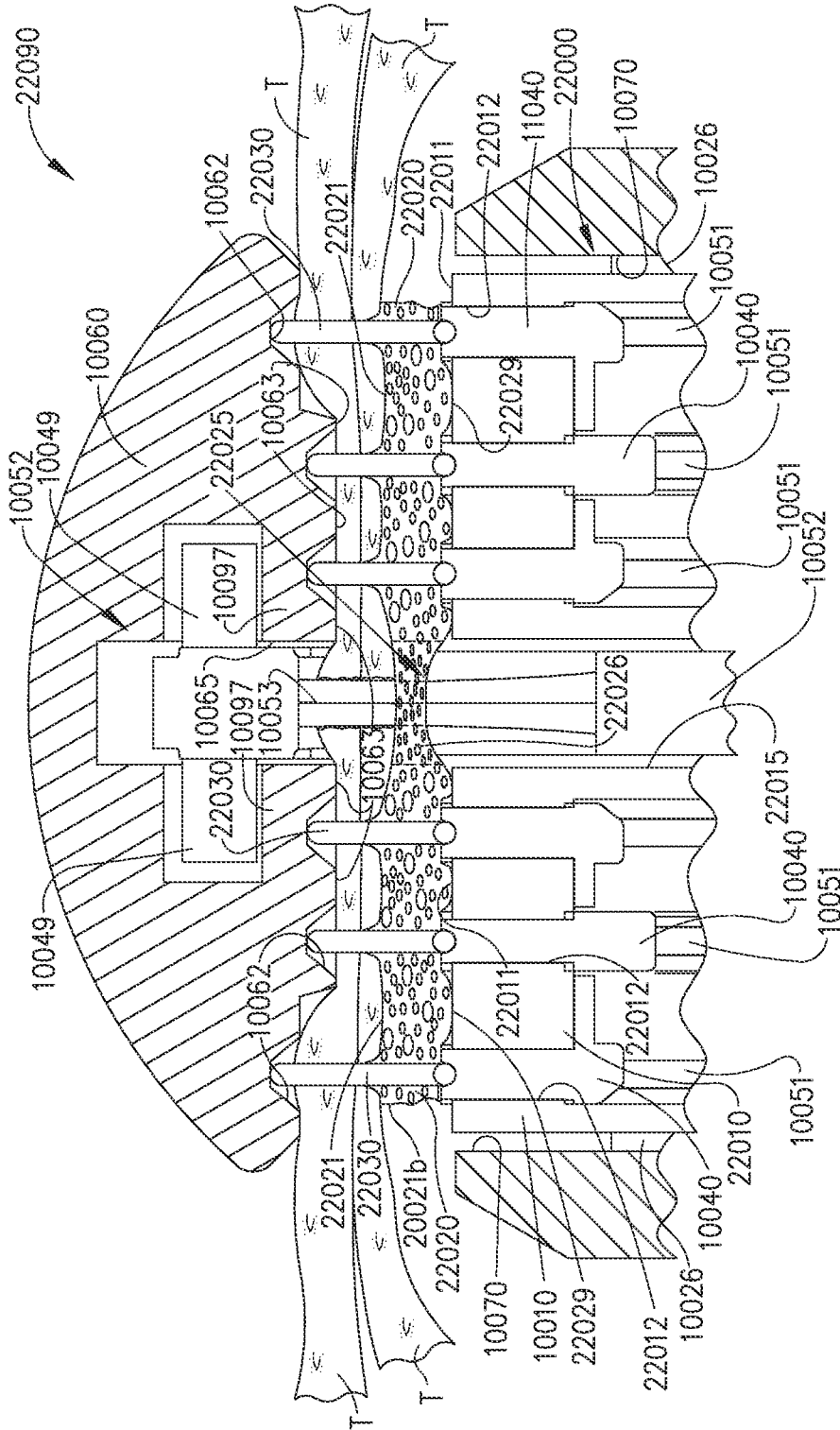

FIG. 11

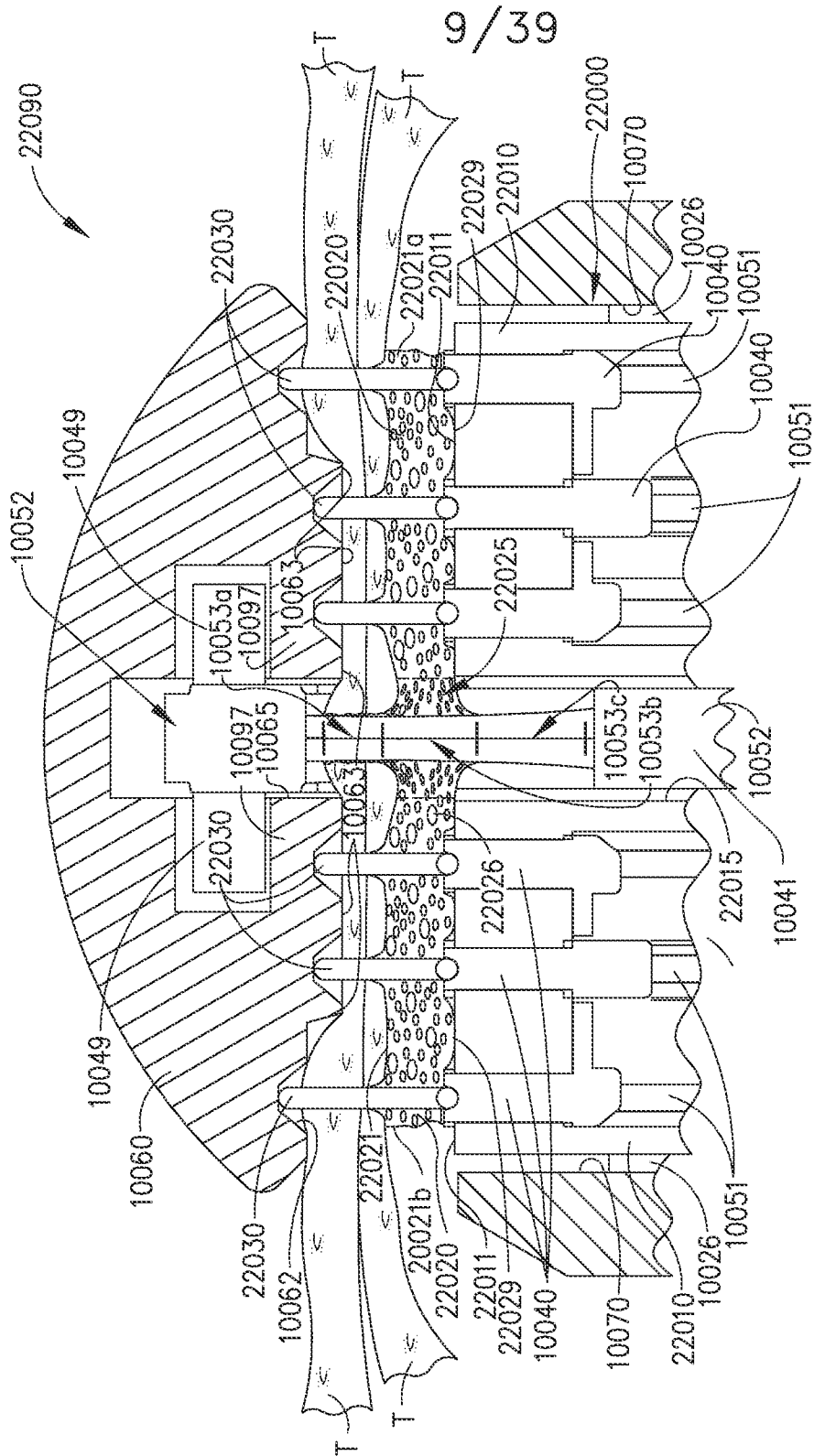

FIG. 12

10/39

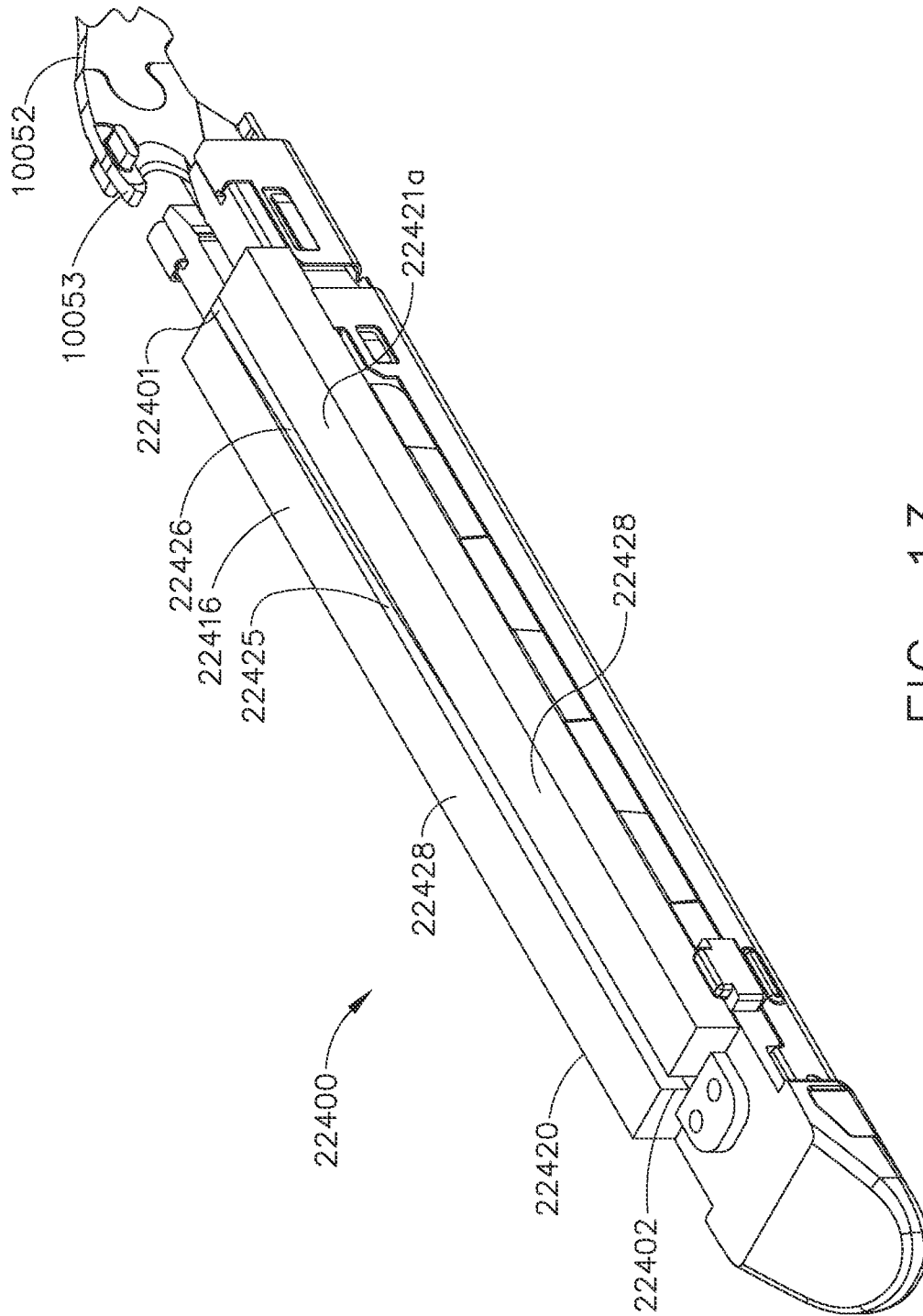

FIG. 13

11/39

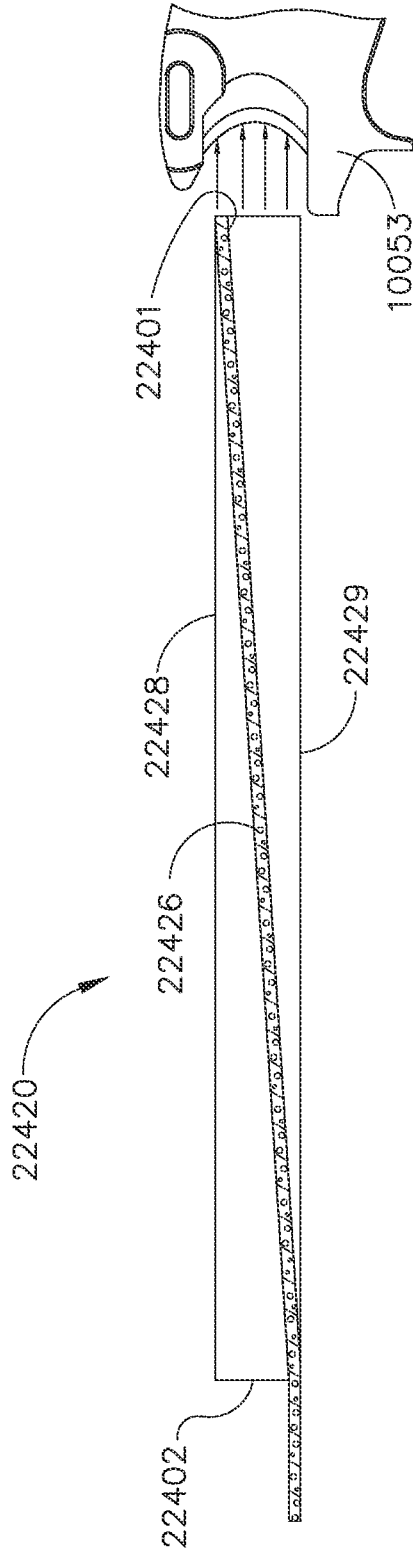

FIG. 14

12/39

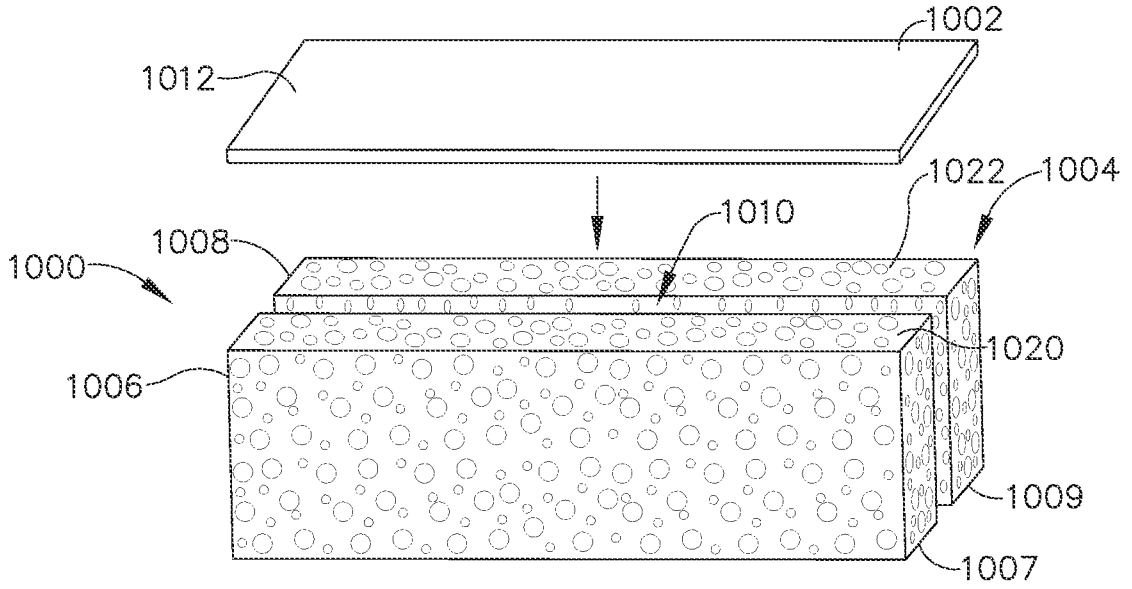

FIG. 15

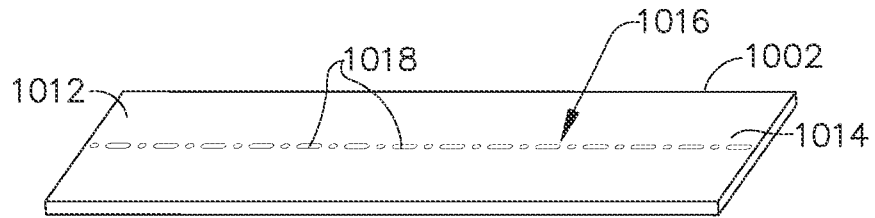

FIG. 16

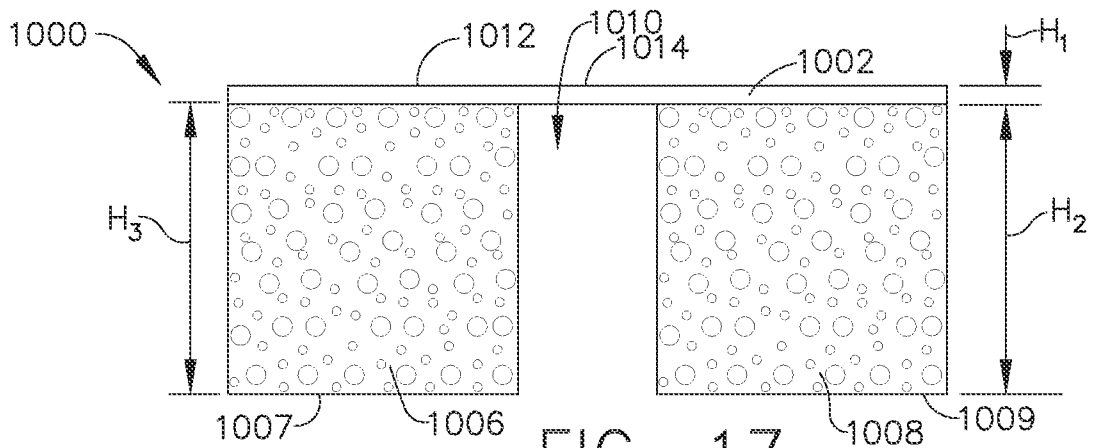

FIG. 17

13/39

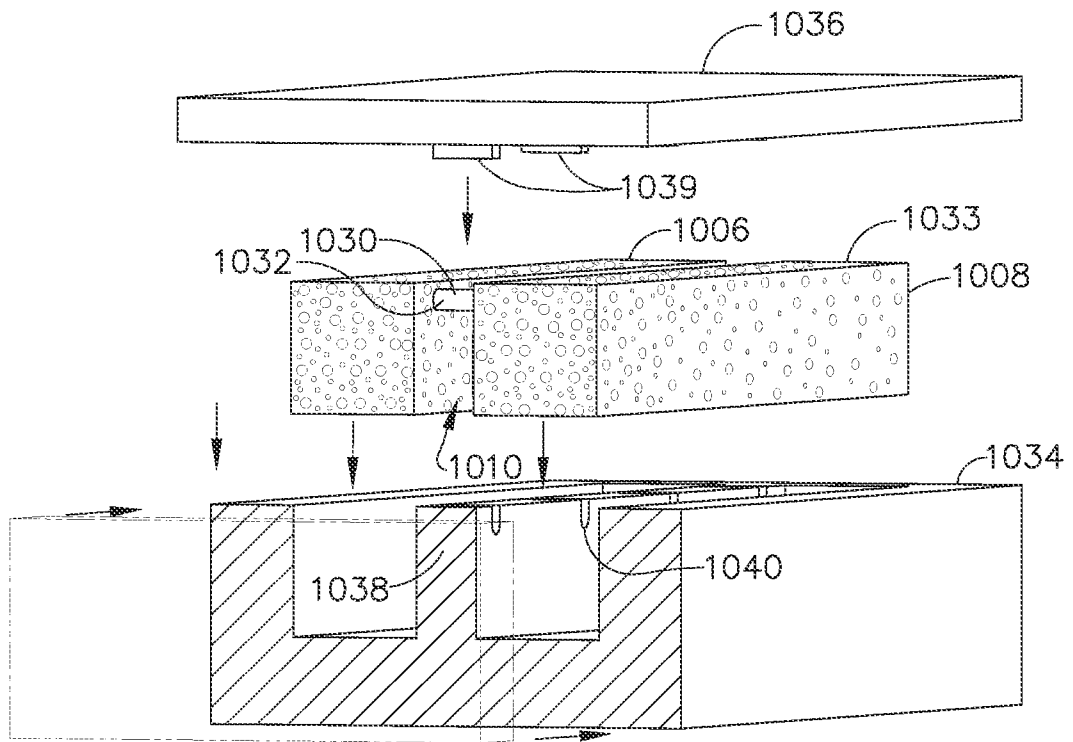

FIG. 18

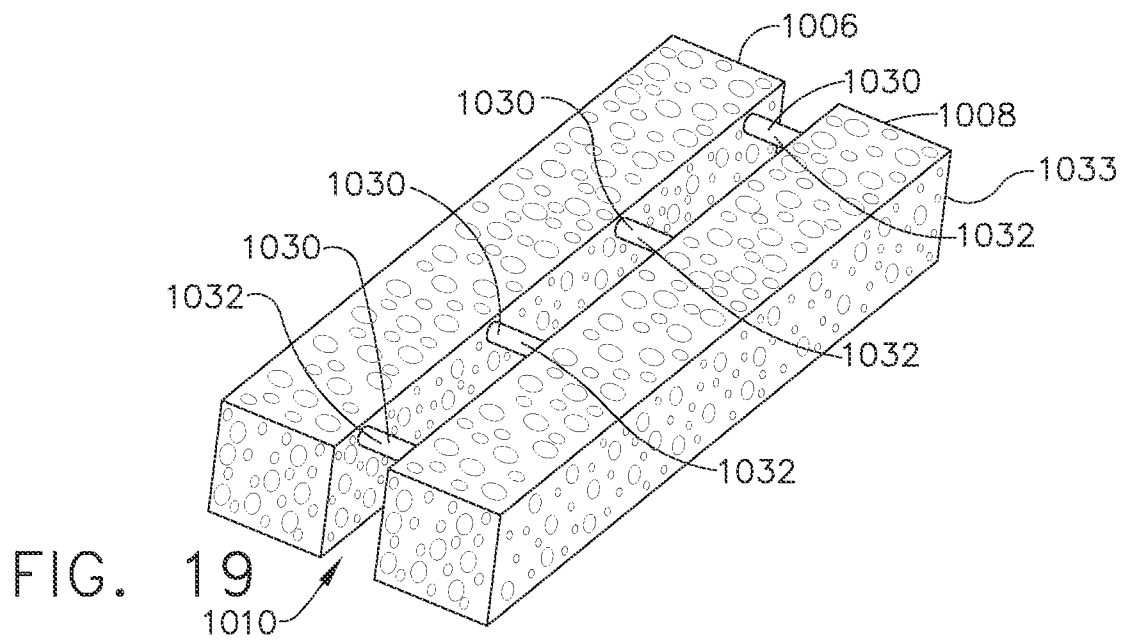
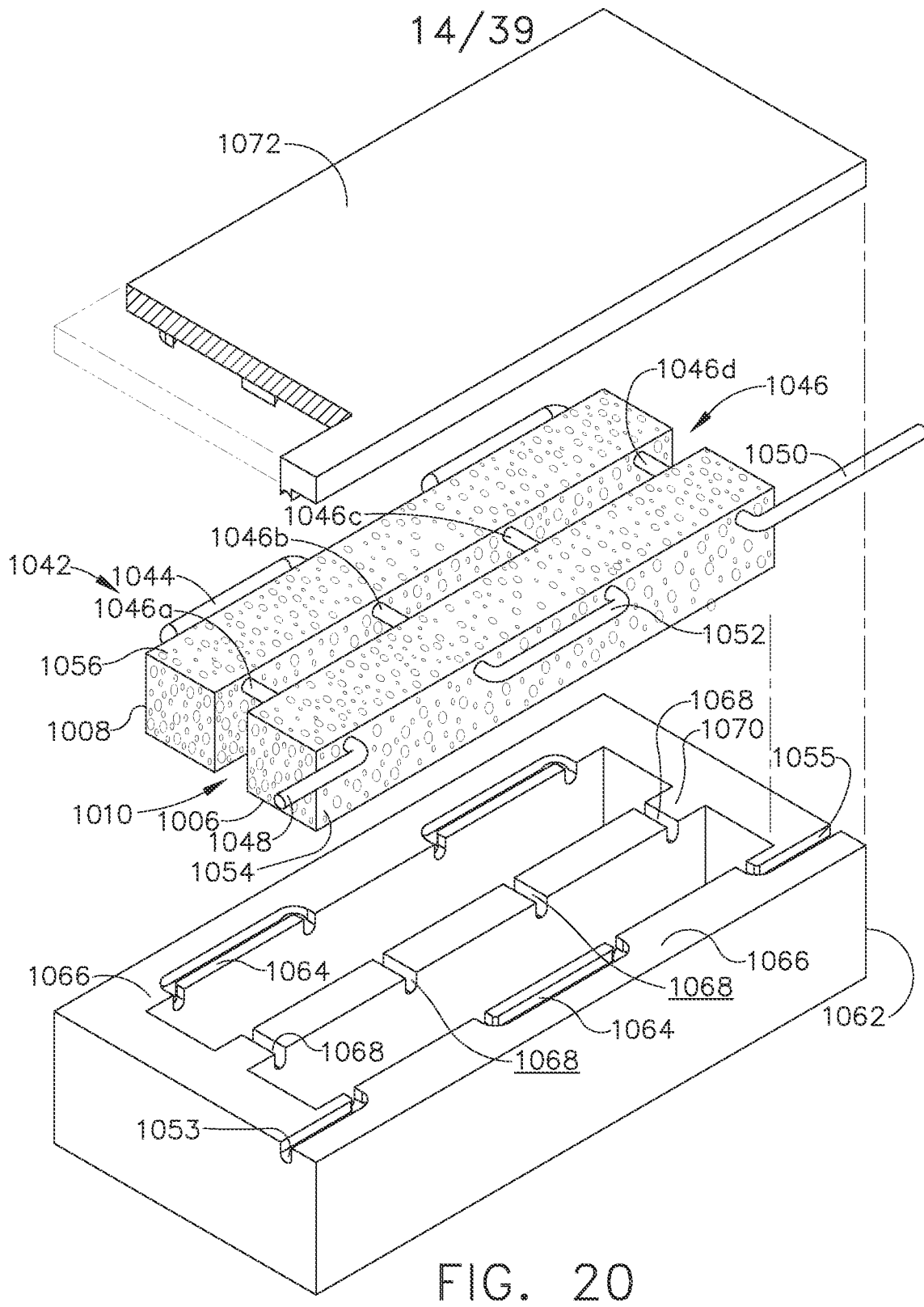

FIG. 19



15/39

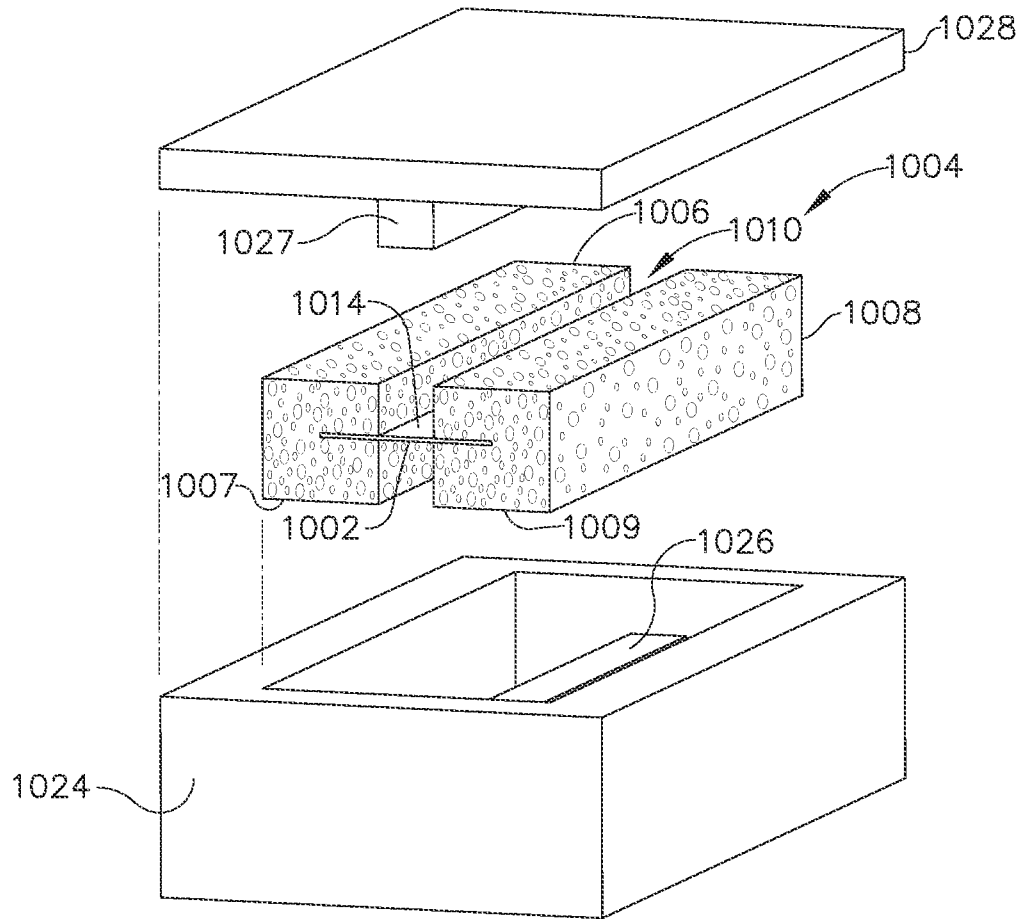

FIG. 21

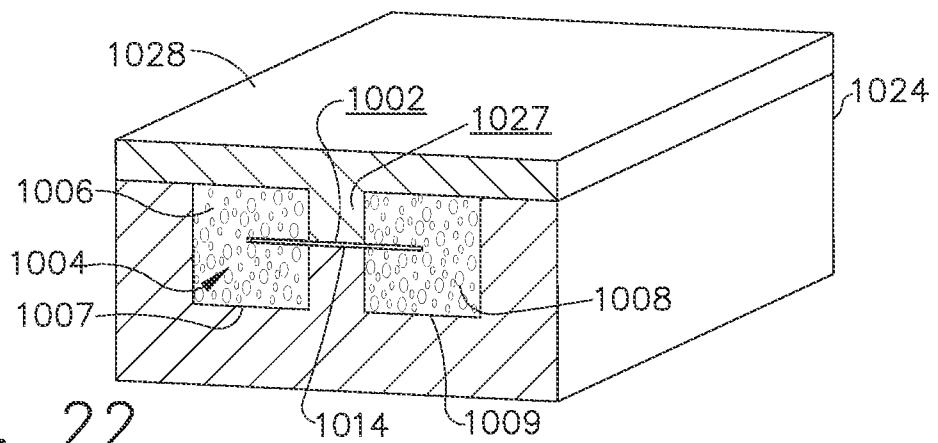
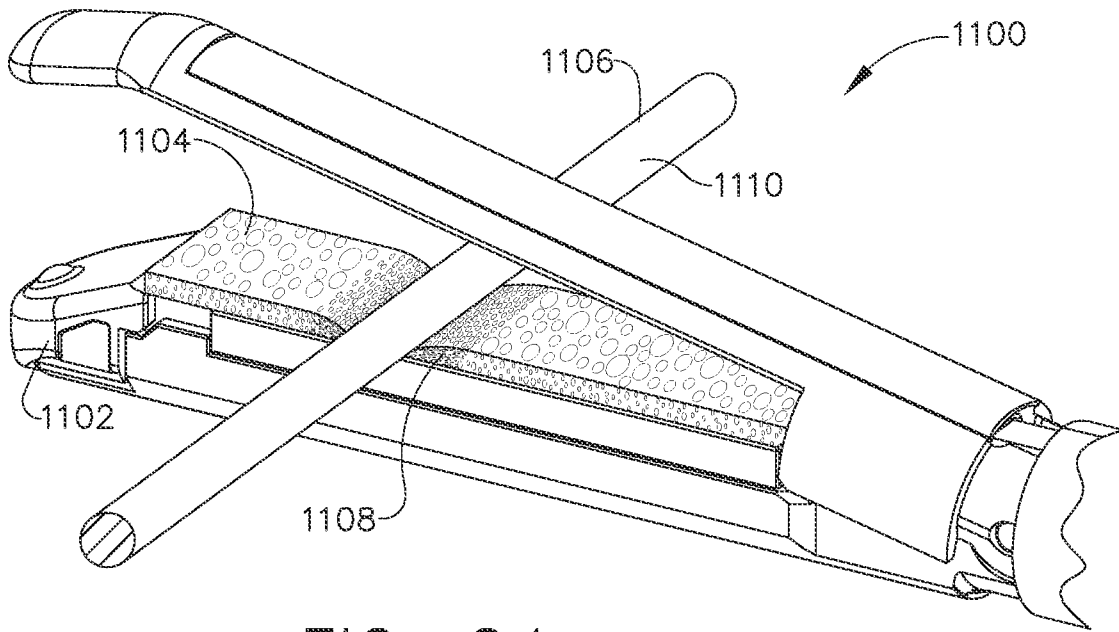
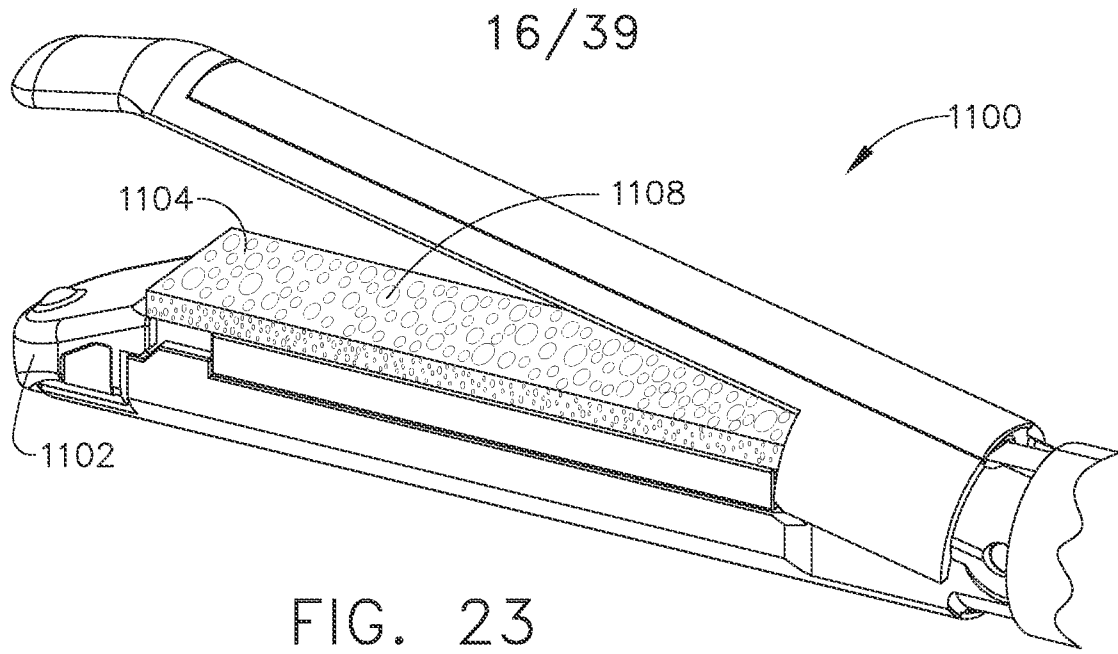

FIG. 22



17/39

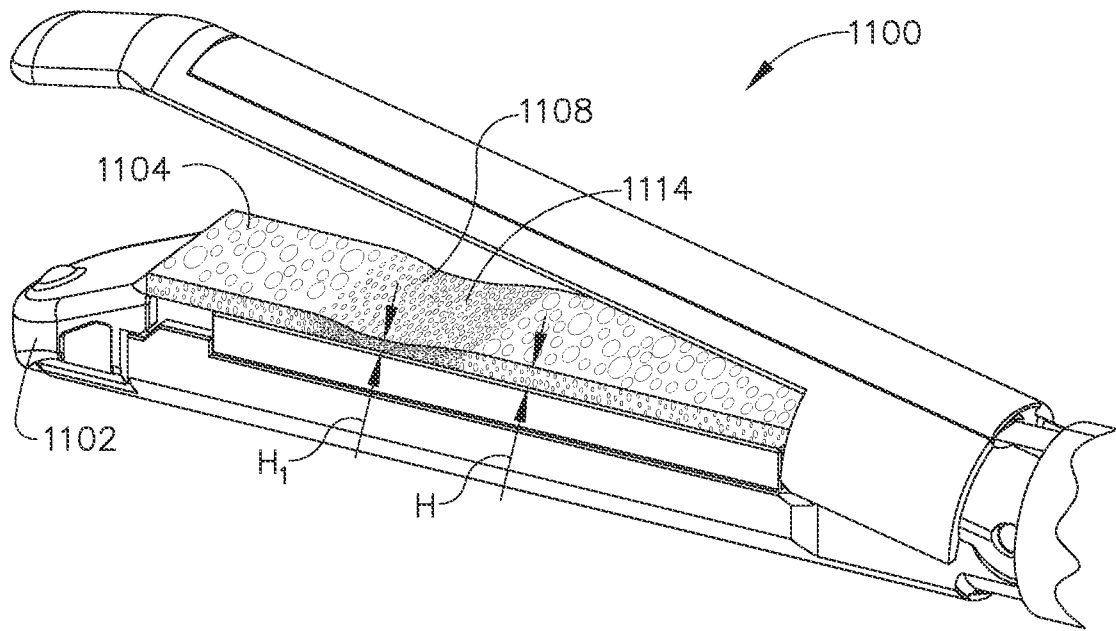

FIG. 25

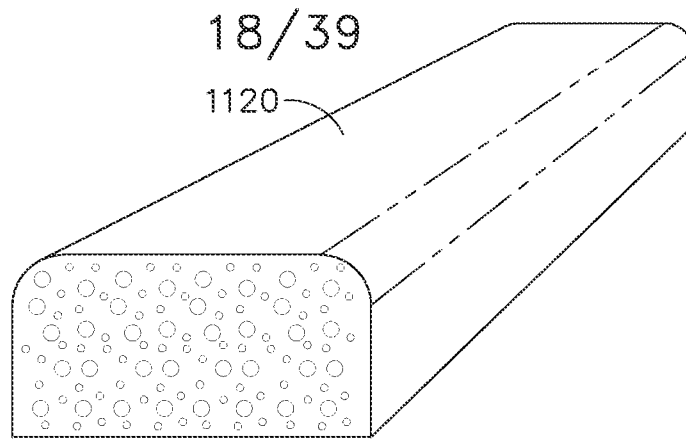

FIG. 26

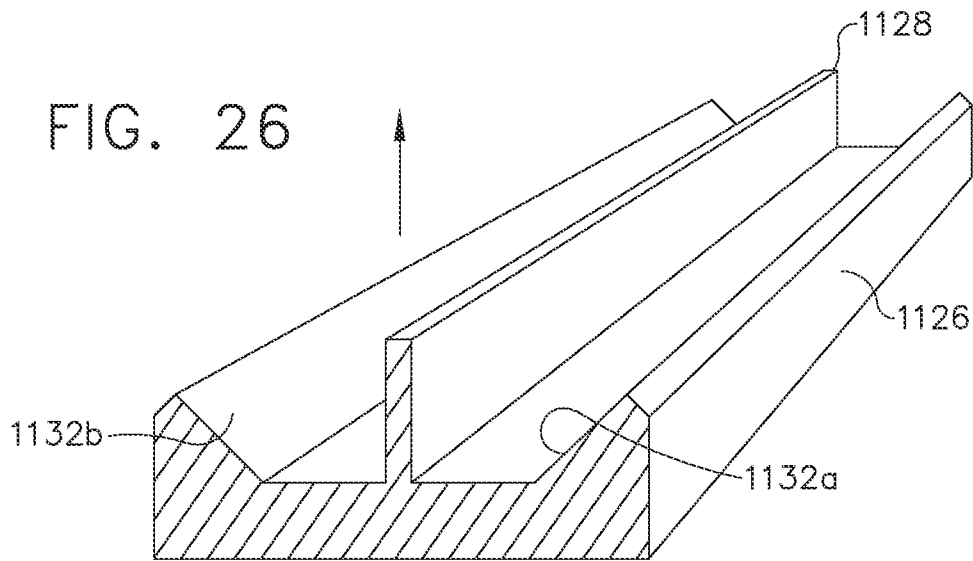

FIG. 27

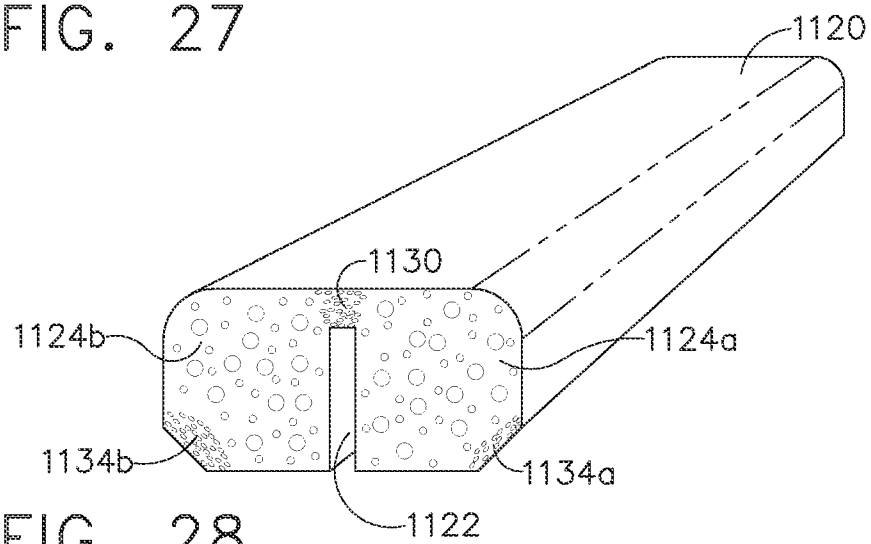

FIG. 28

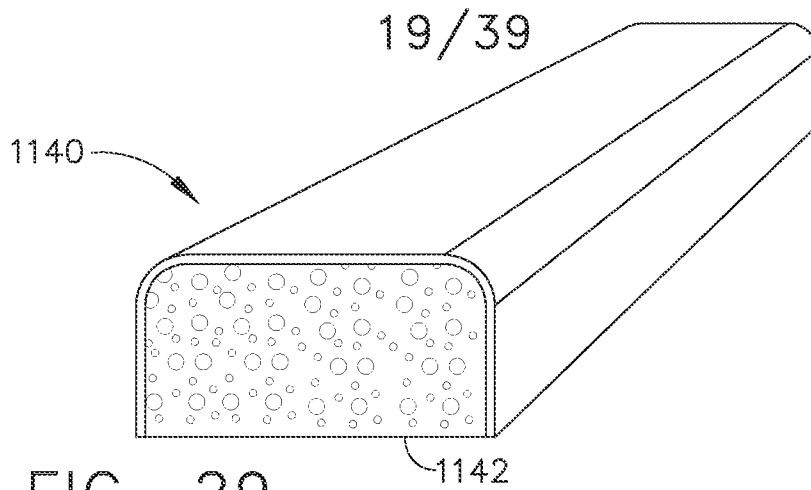

FIG. 29

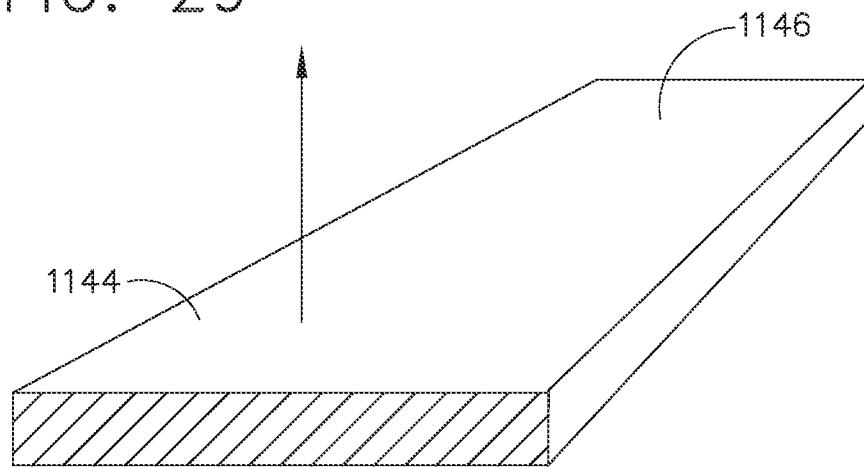

FIG. 30

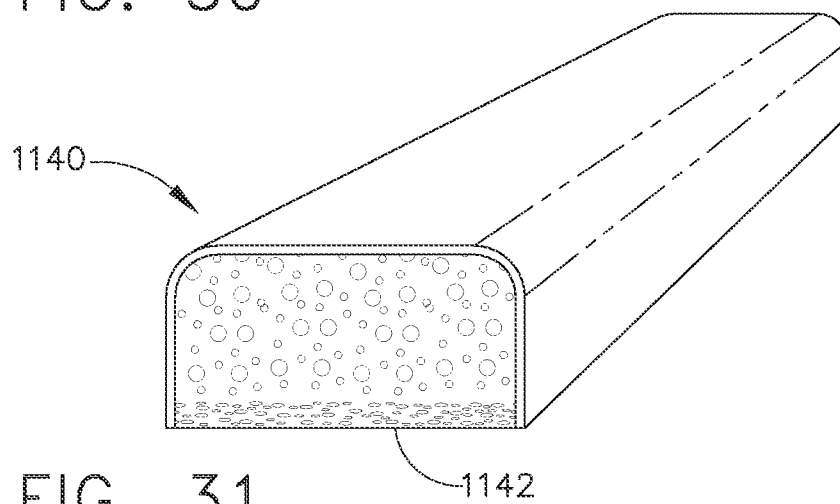

FIG. 31

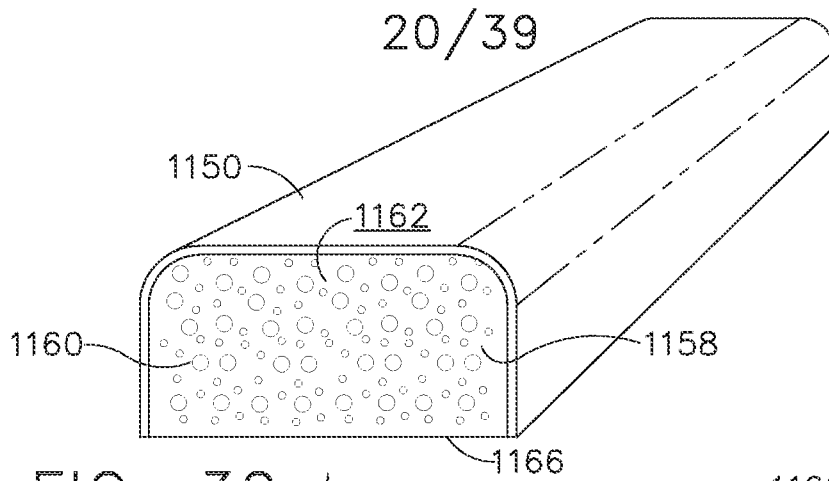

FIG. 32

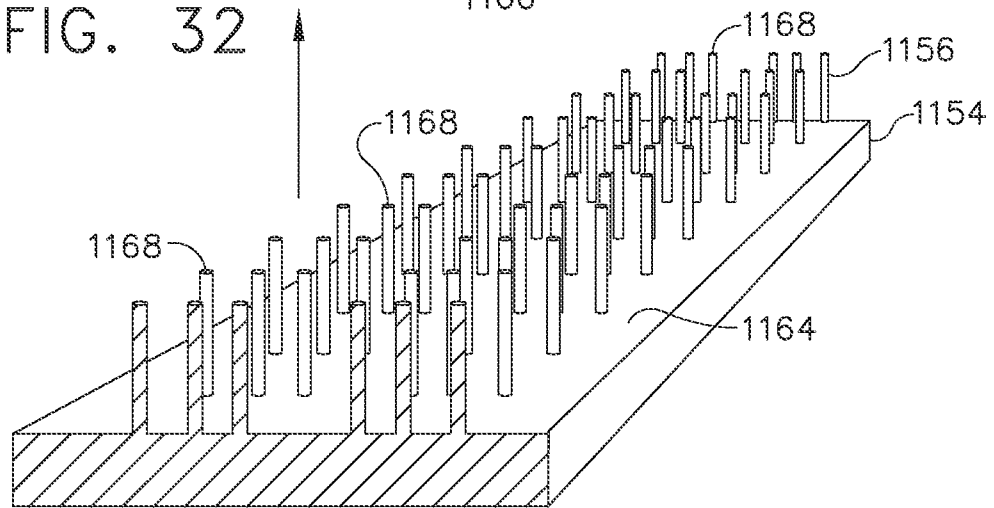

FIG. 33

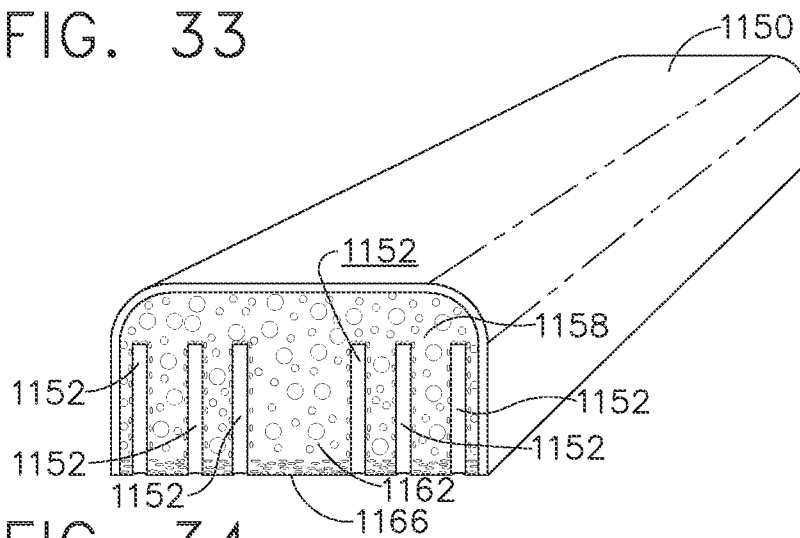

FIG. 34

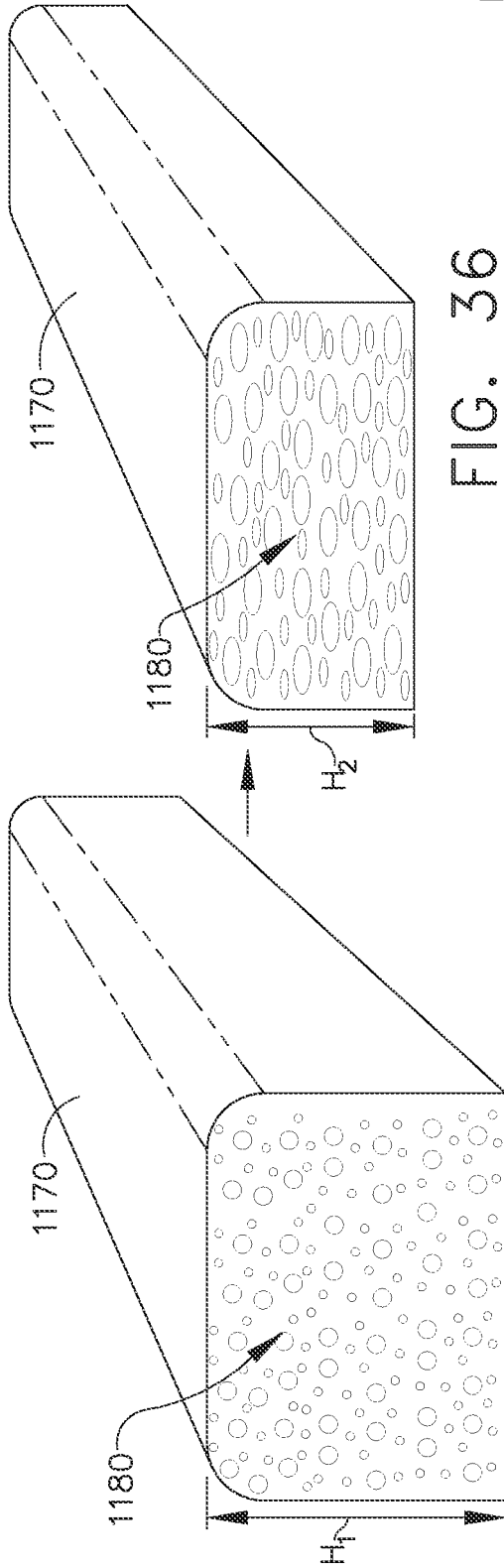

FIG. 36

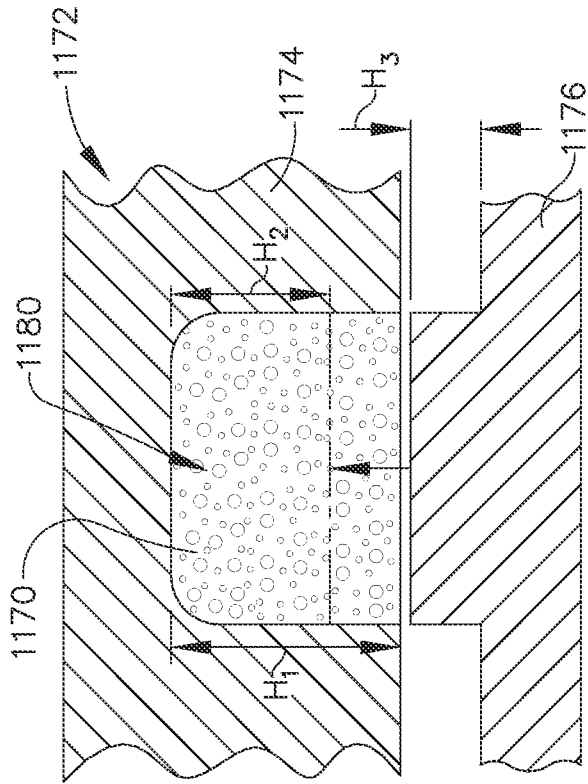

FIG. 37

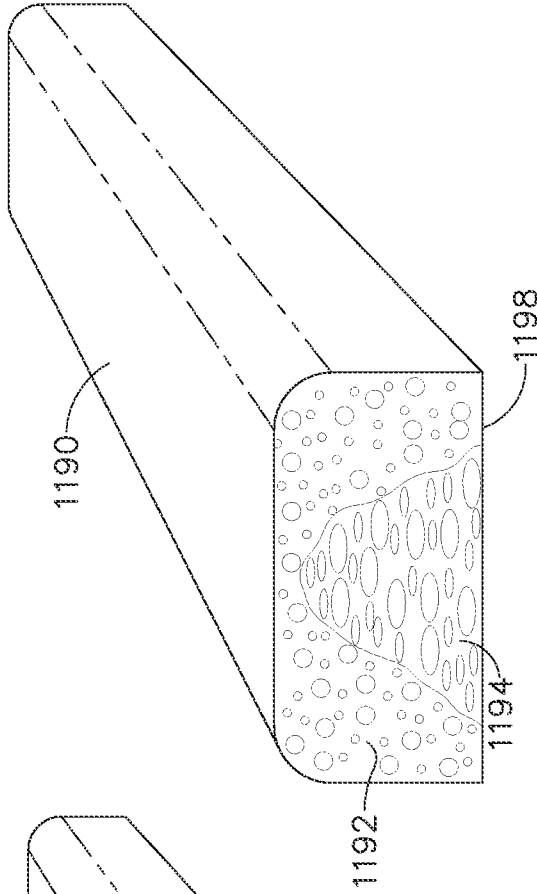

FIG. 38

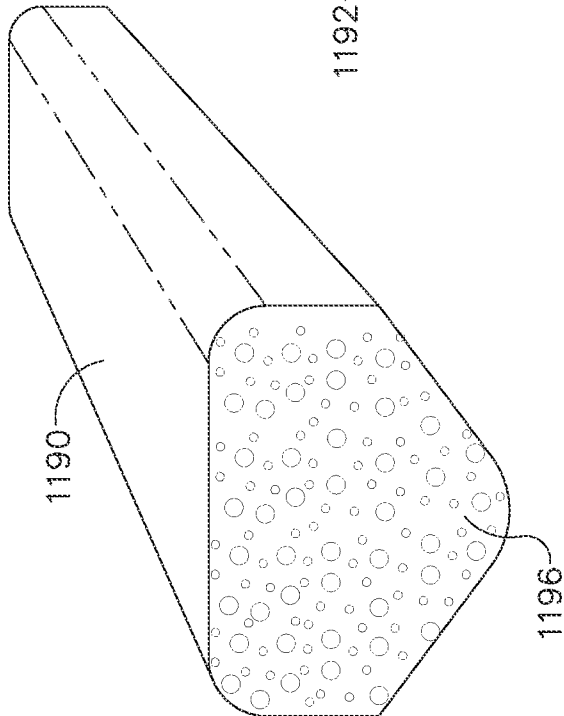

FIG. 39

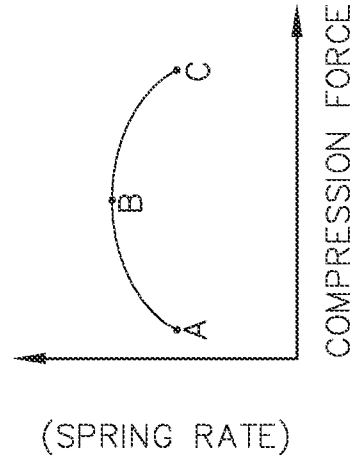

FIG. 40

23/39

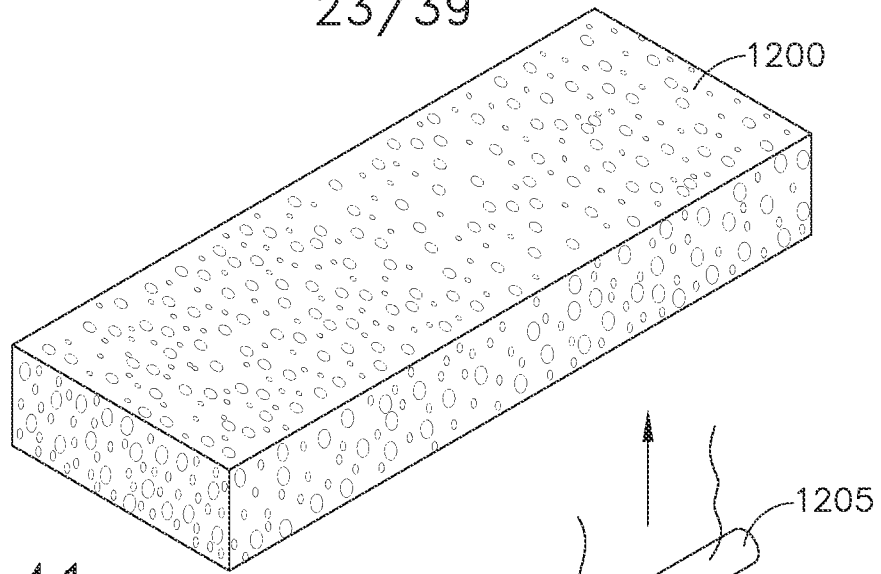

FIG. 41

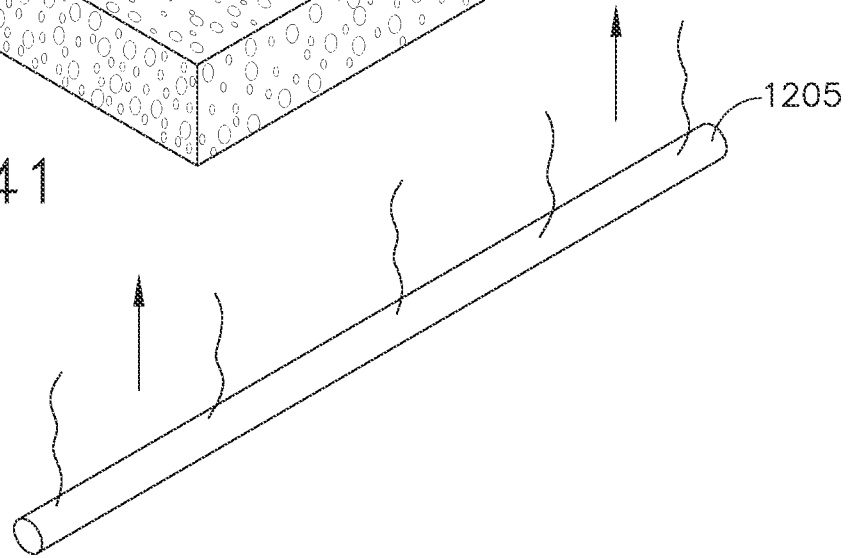

FIG. 42

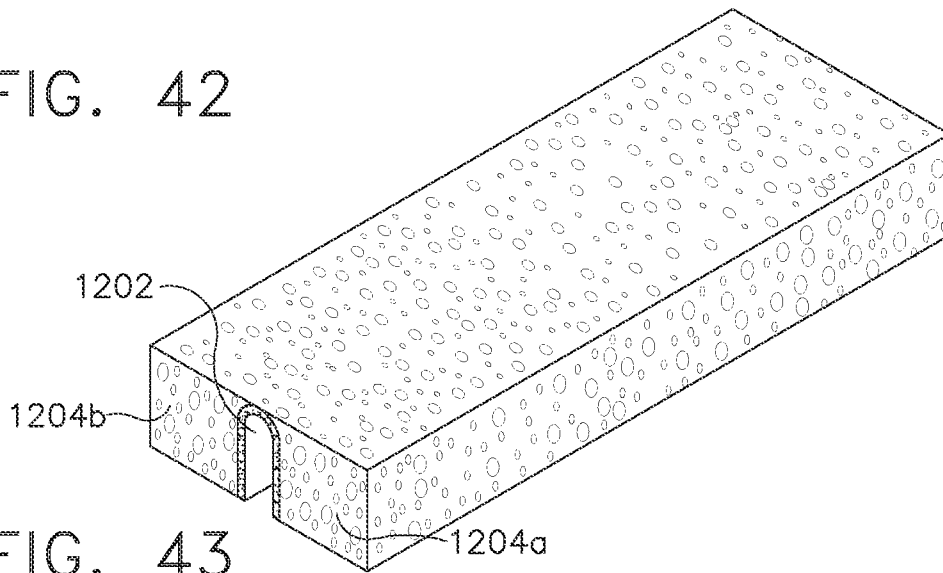
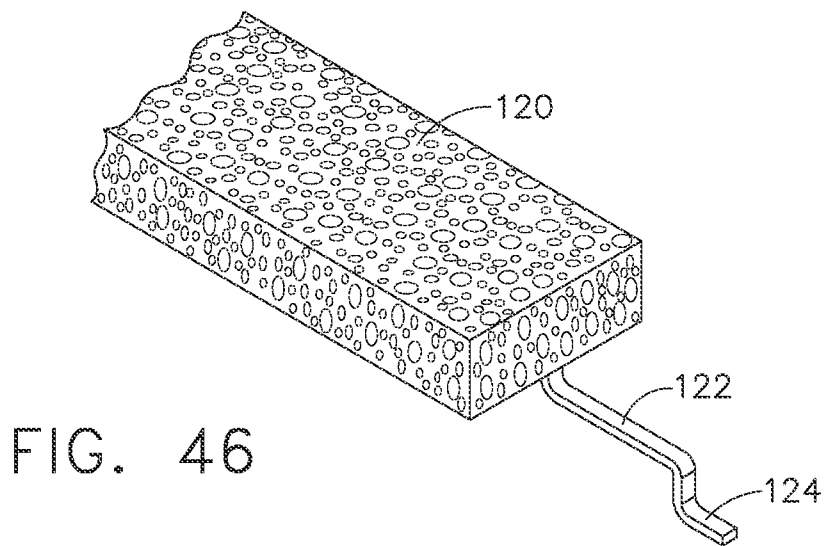
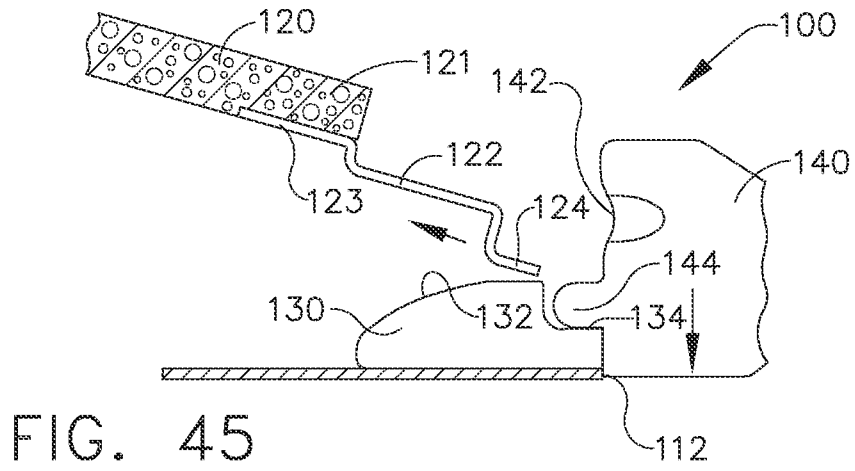
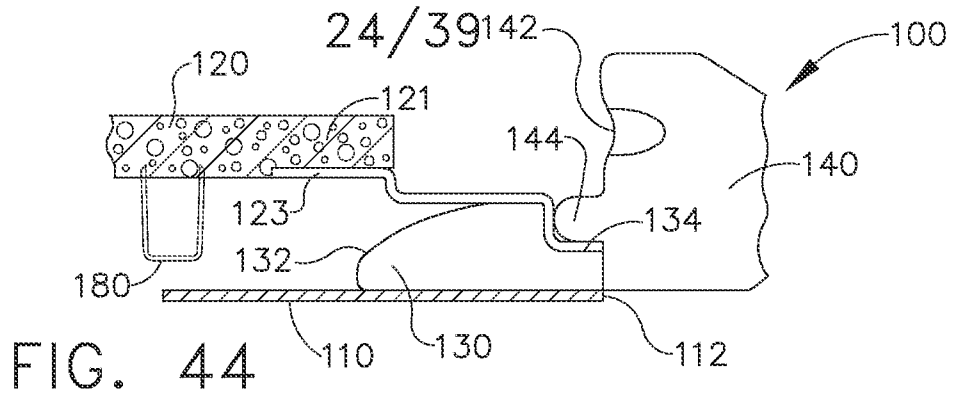

FIG. 43



25/39

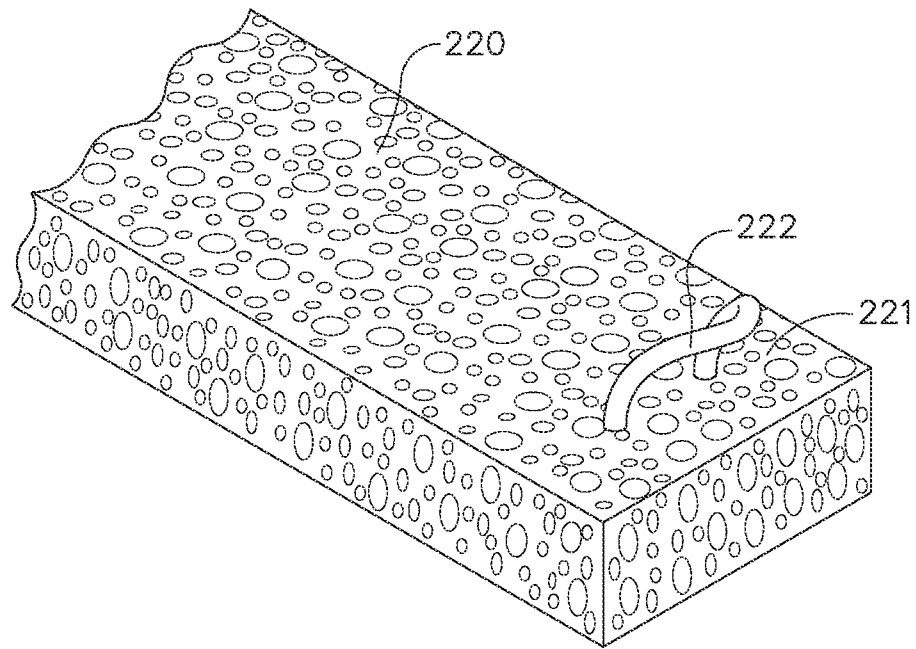

FIG. 47

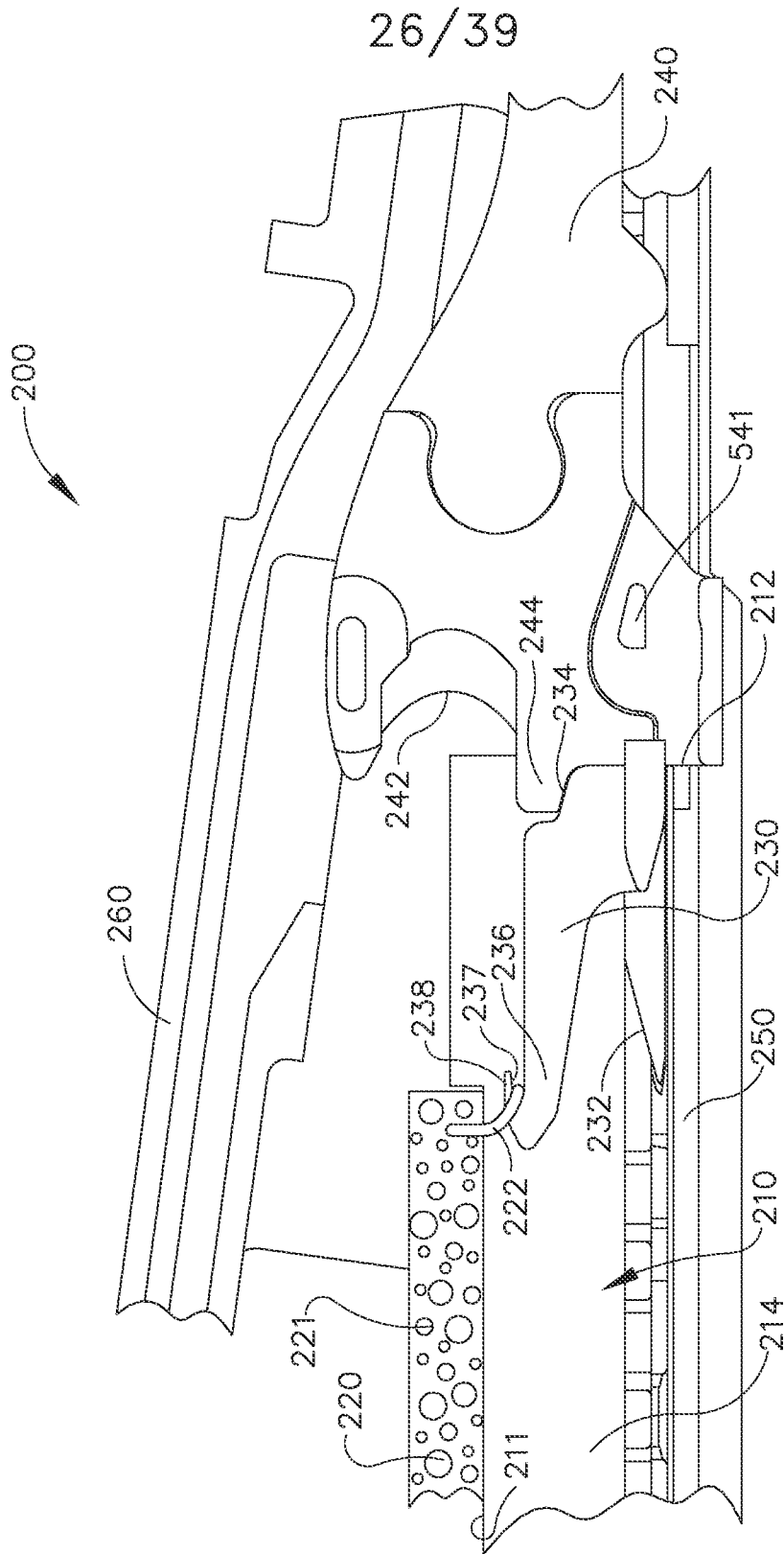

FIG. 48

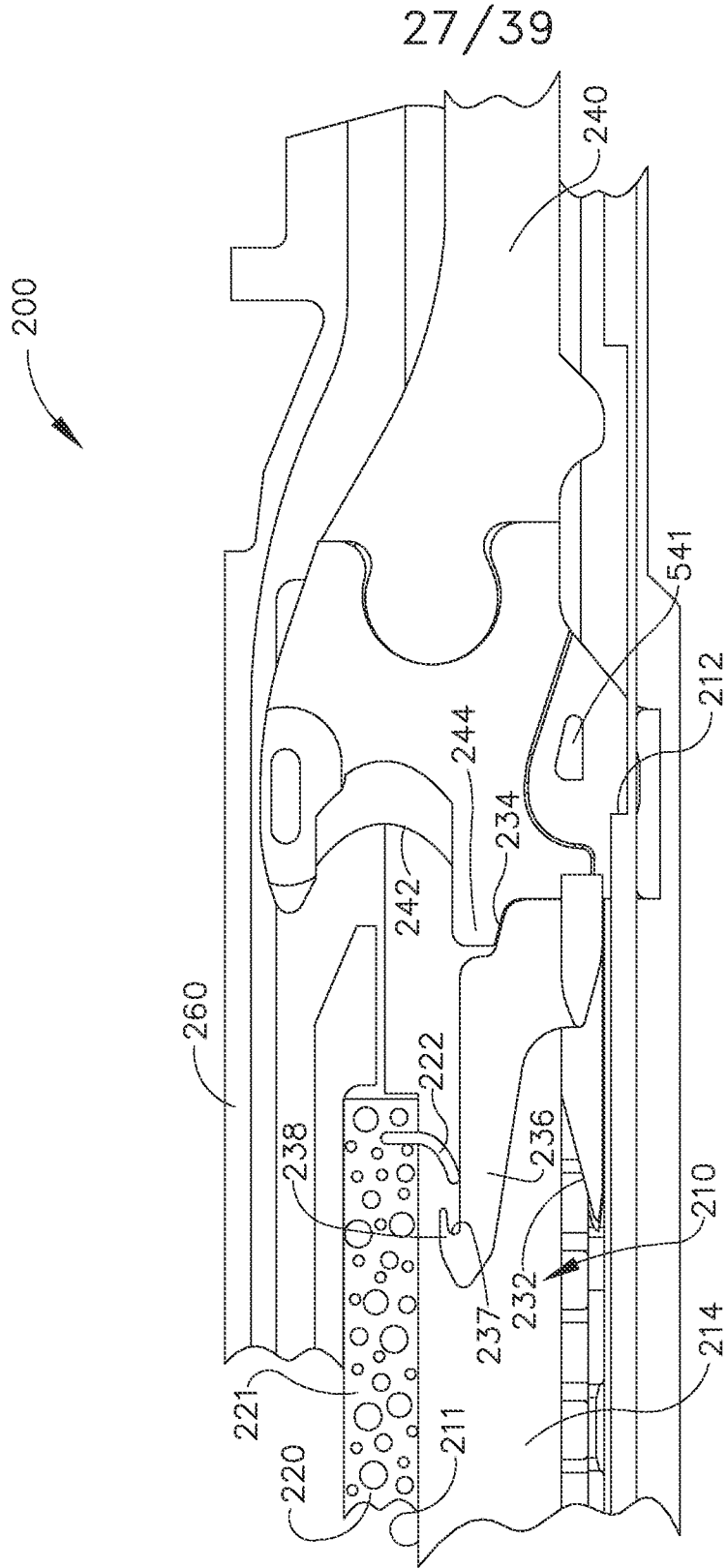

FIG. 49

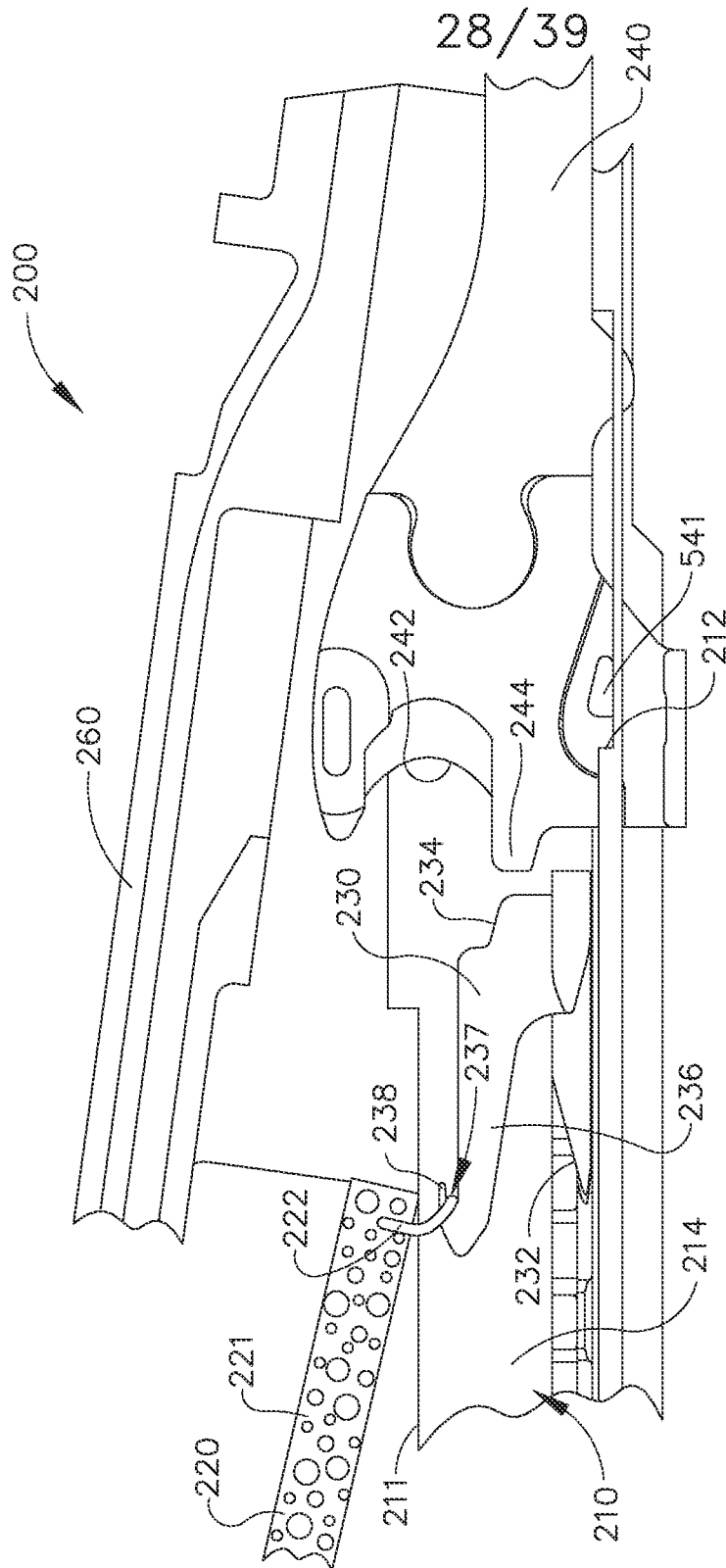

FIG. 50

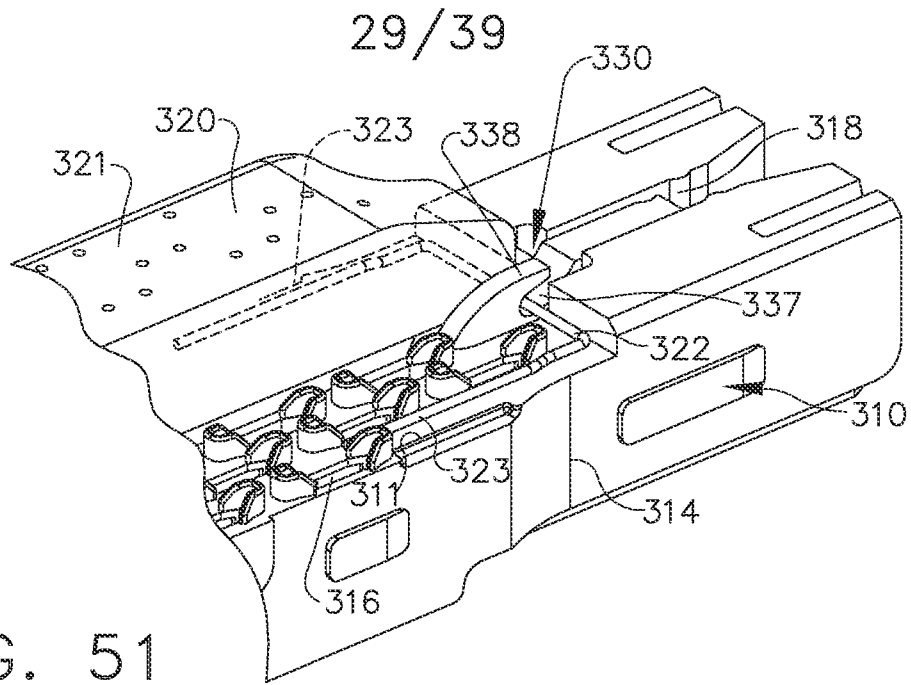

FIG. 51

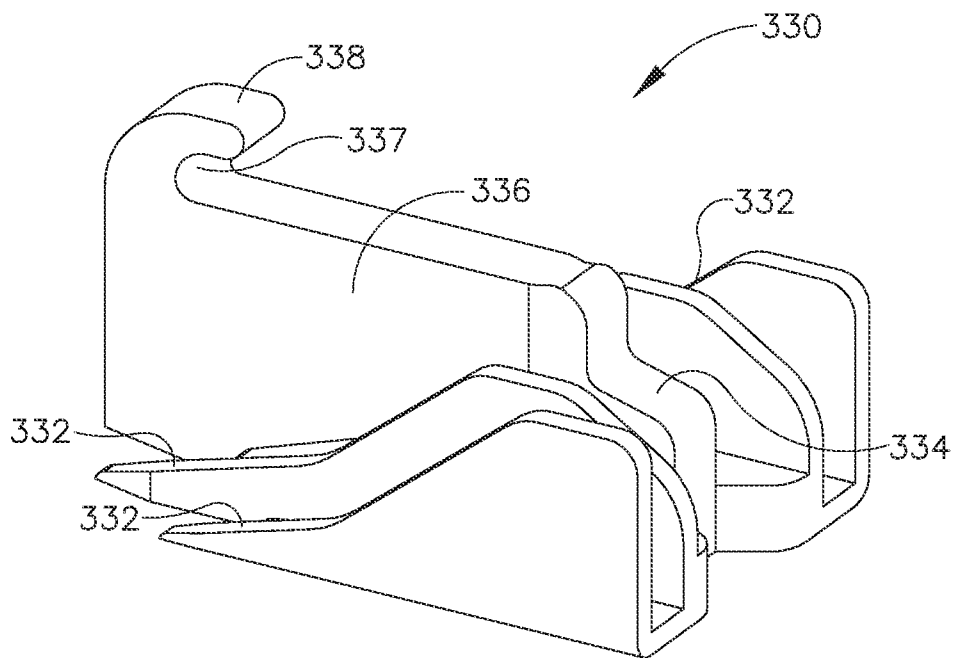

FIG. 52

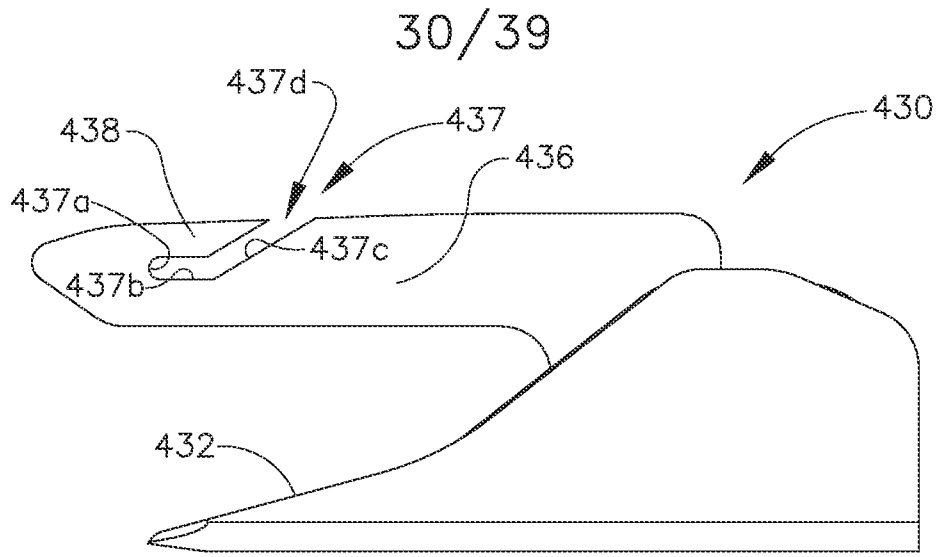

FIG. 54

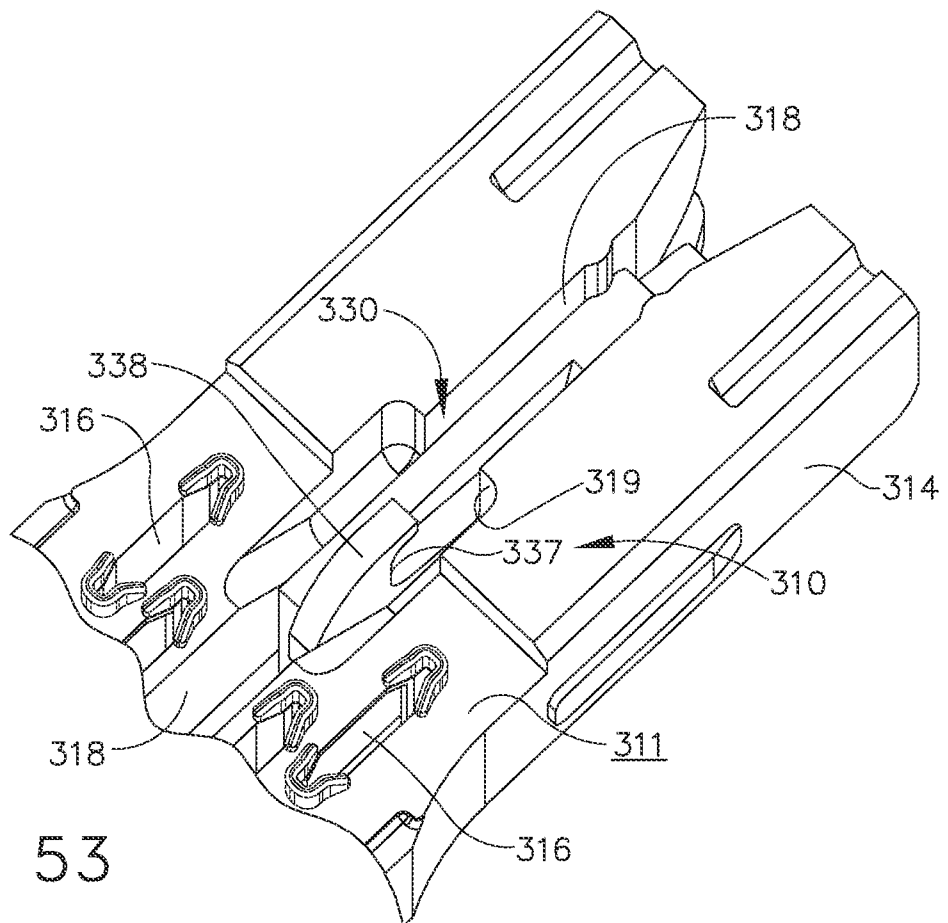

FIG. 53

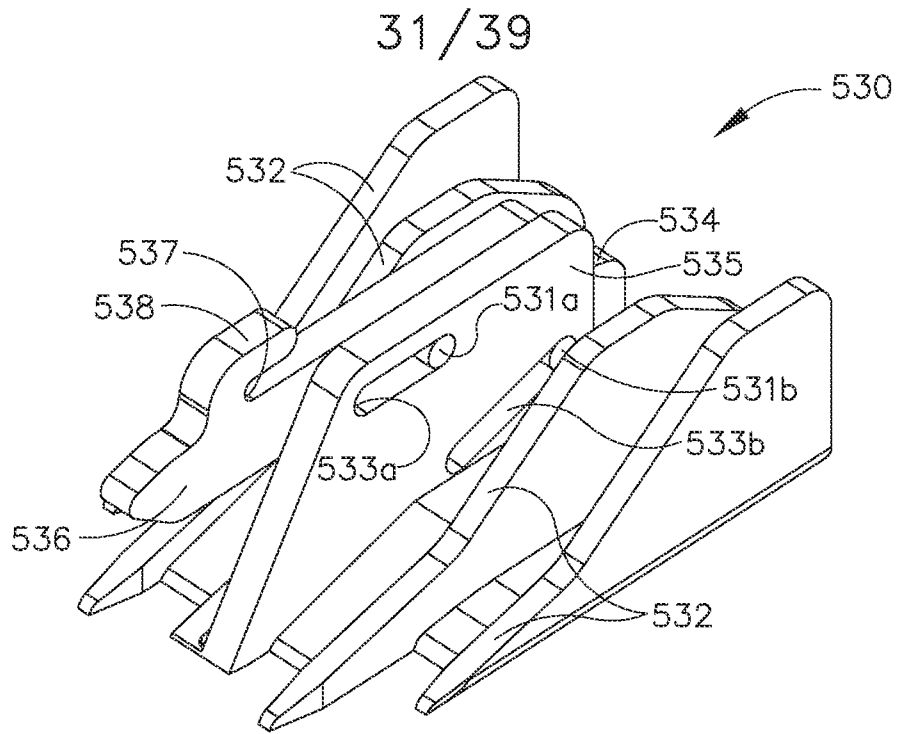

FIG. 55

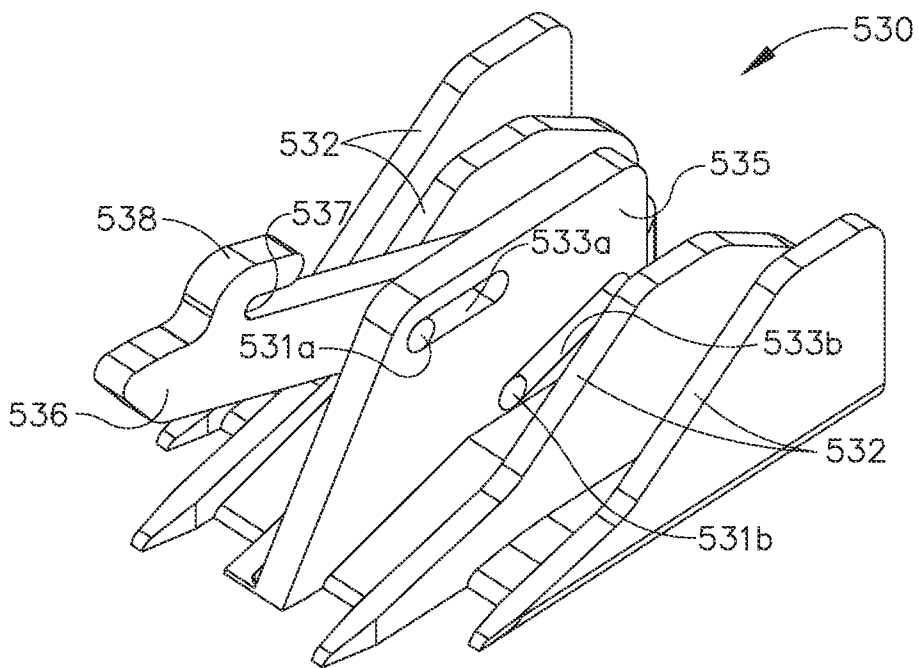

FIG. 56

32/39

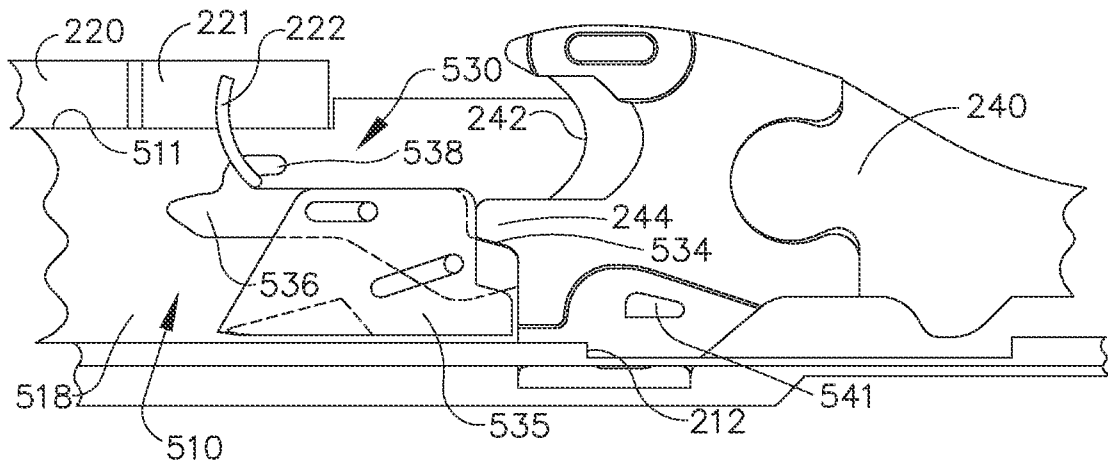

FIG. 57

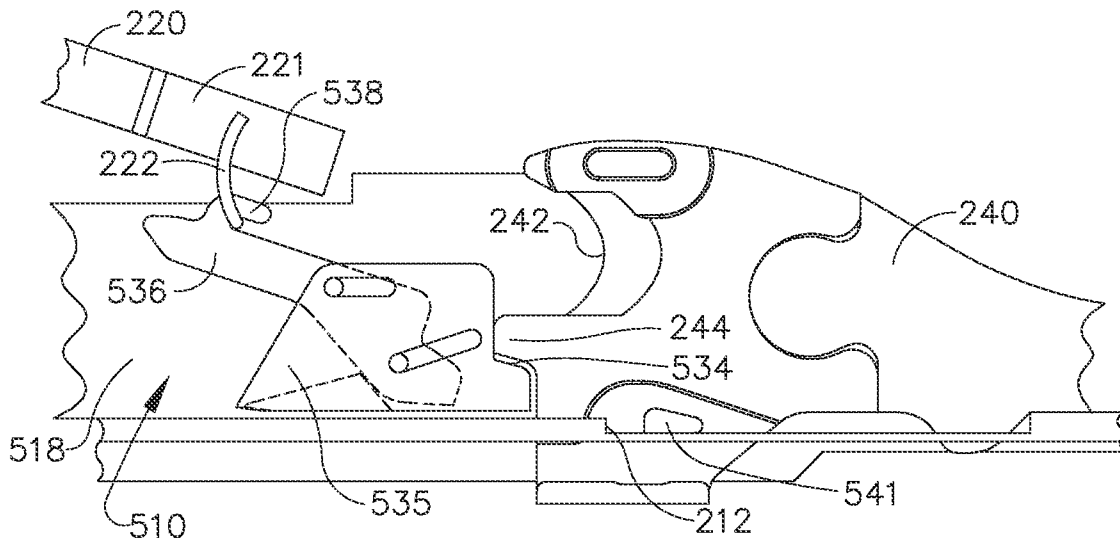

FIG. 58

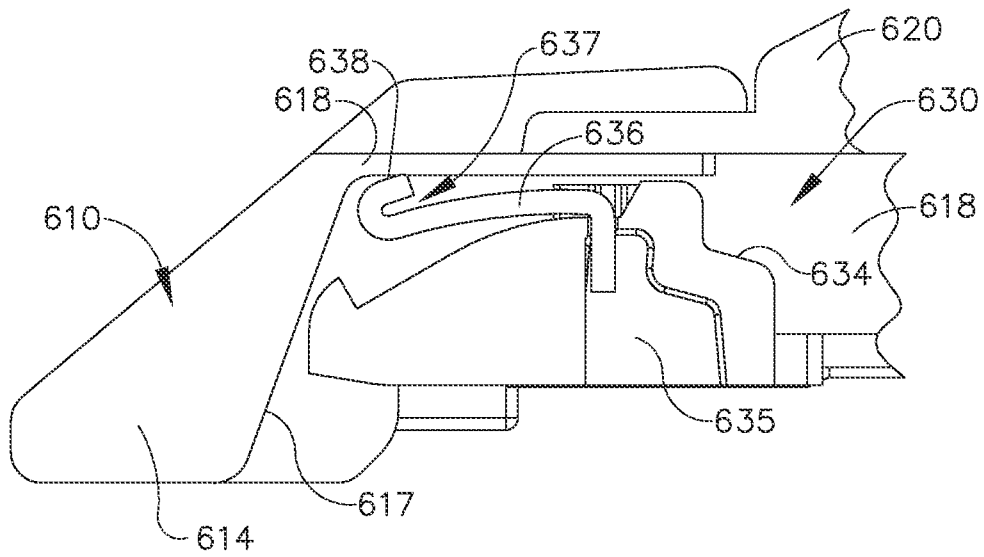

FIG. 60

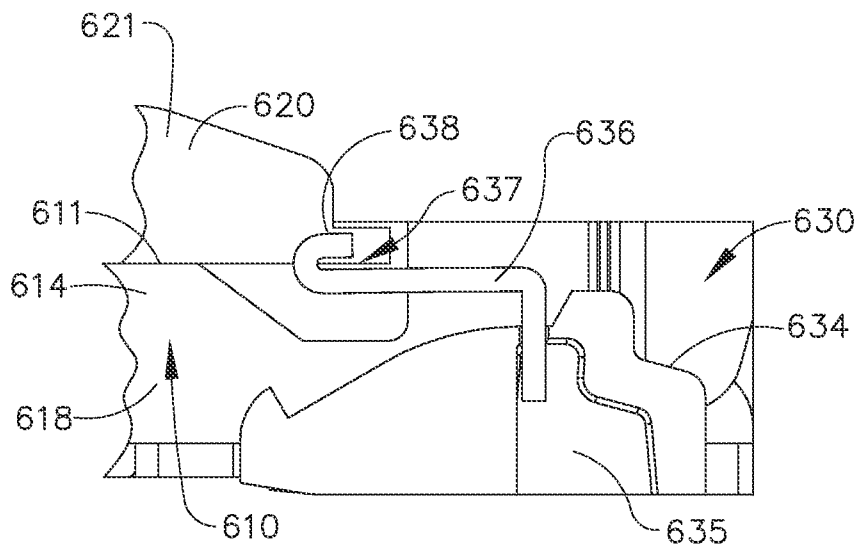

FIG. 59

34/39

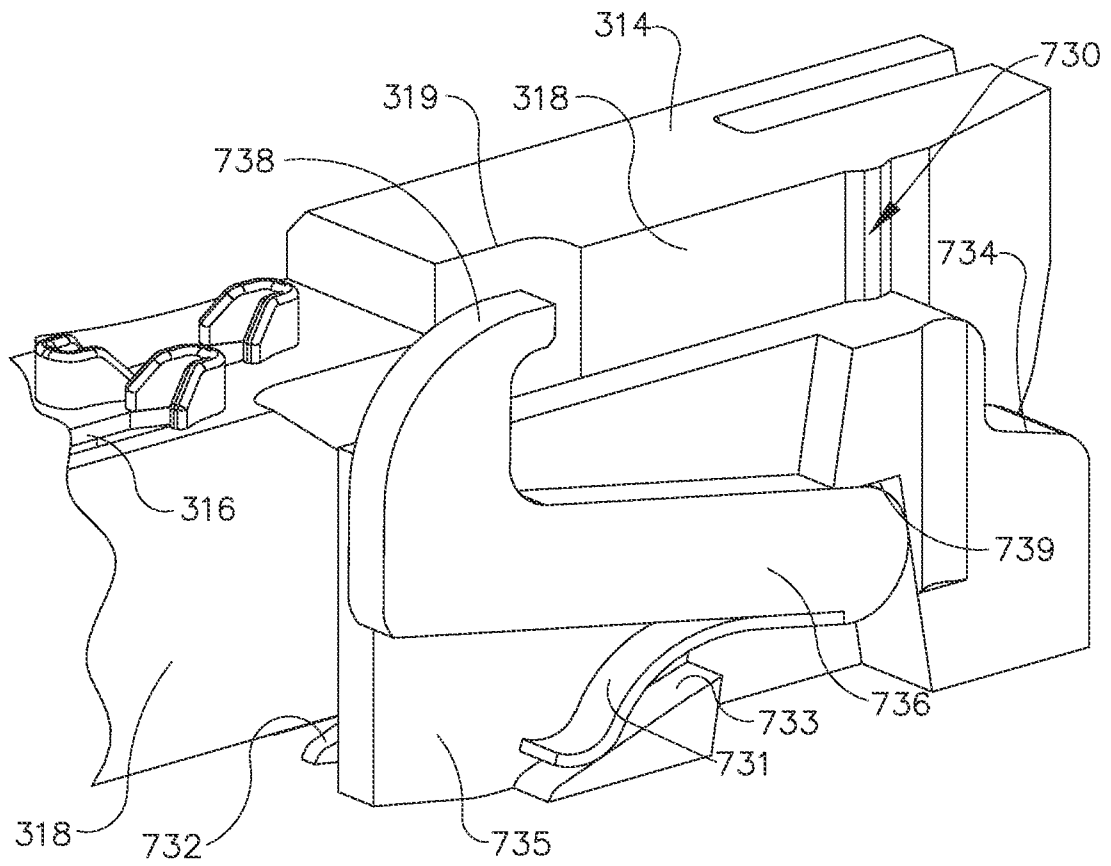

FIG. 61

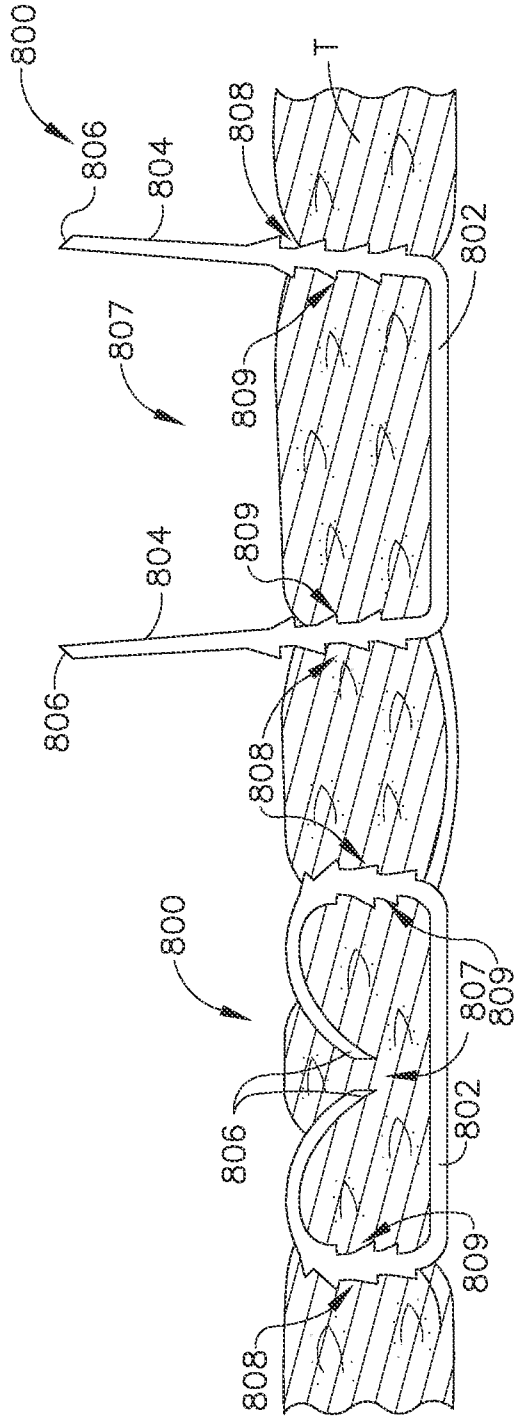

FIG. 62

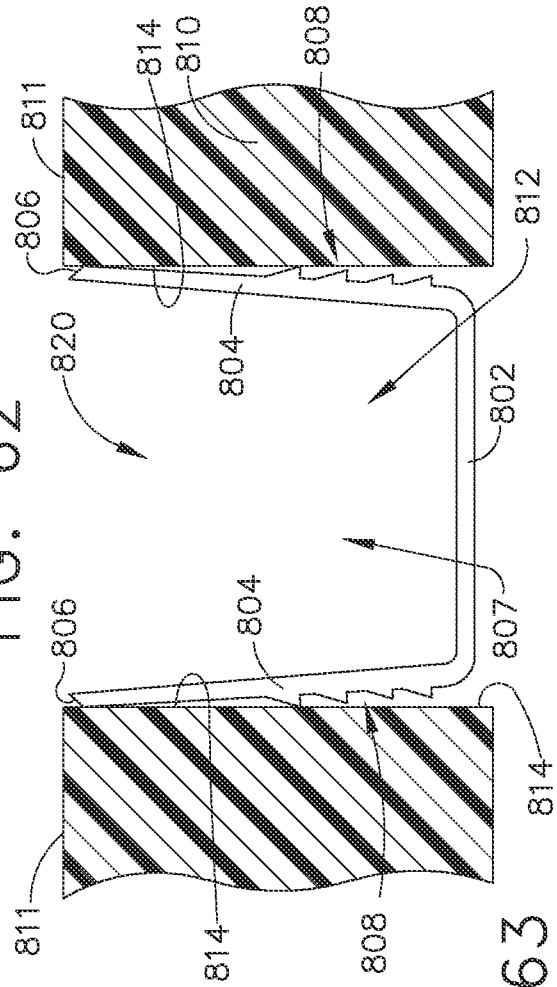

FIG. 63

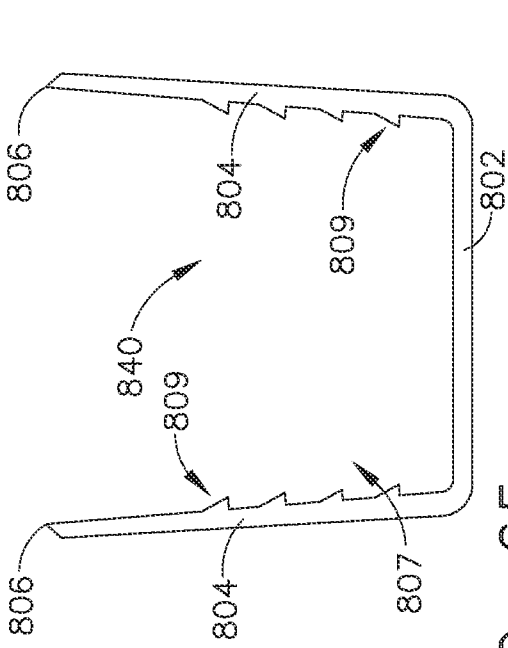

FIG. 65

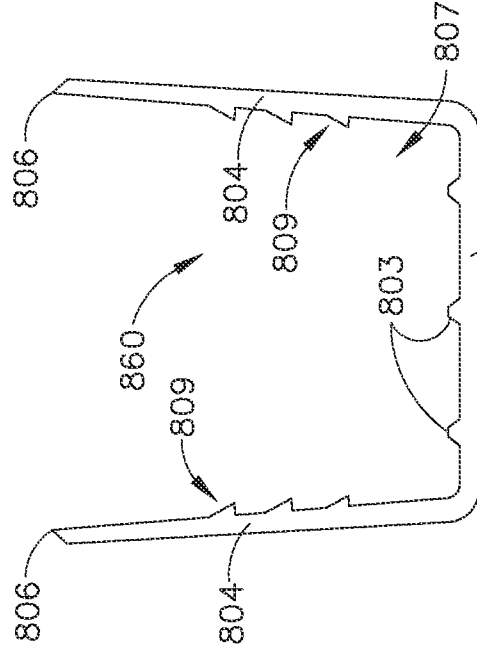

FIG. 67

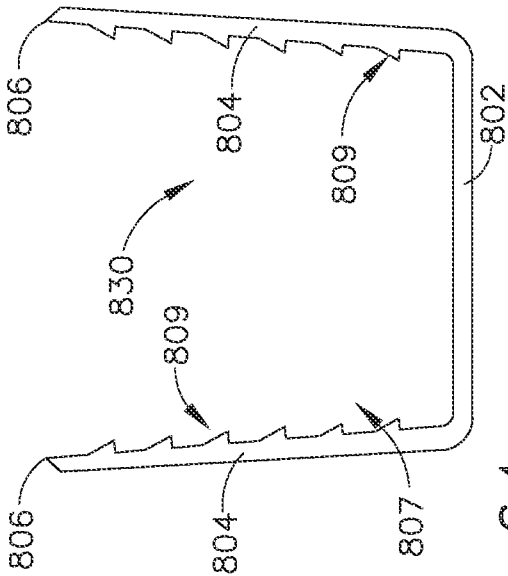

FIG. 64

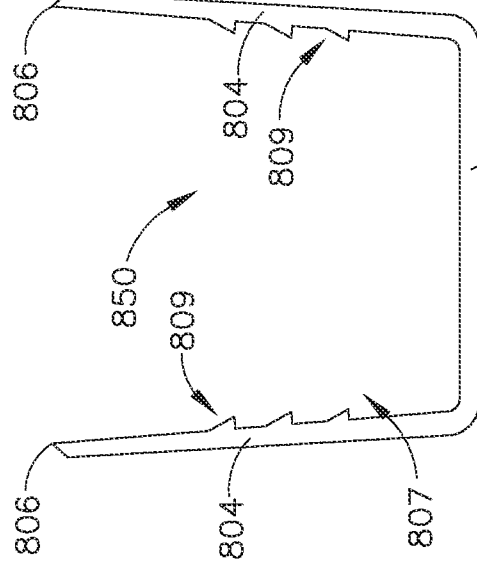

FIG. 66

37/39

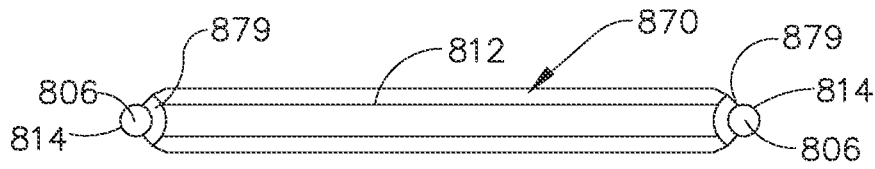

FIG. 69

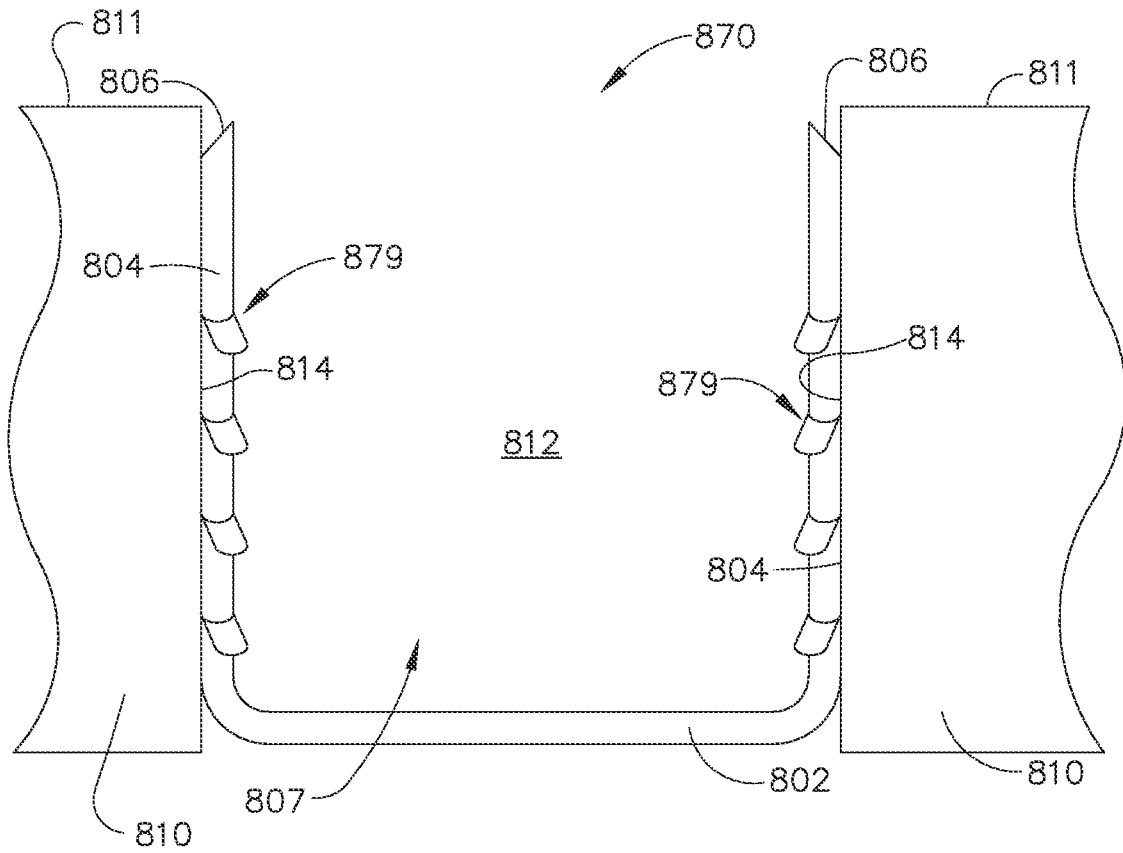

FIG. 68

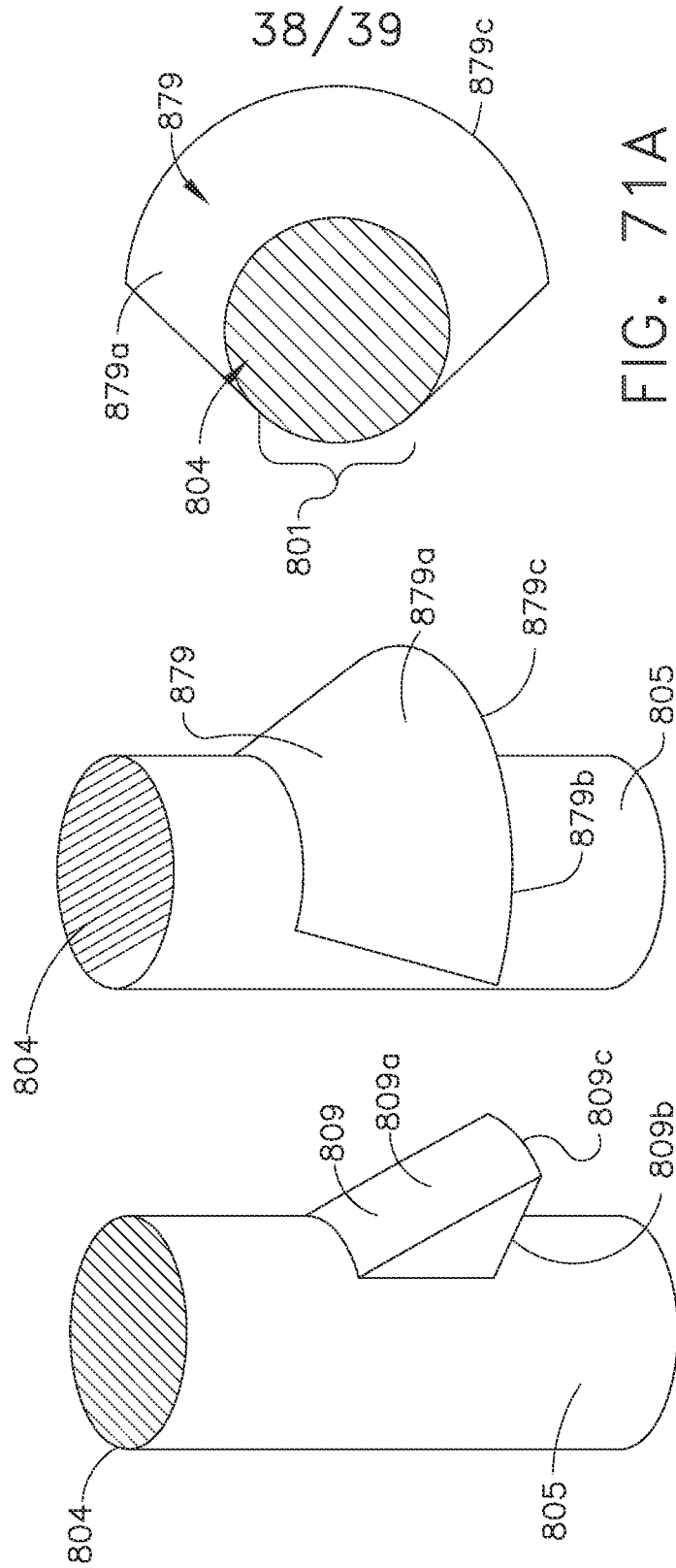

FIG. 70 FIG. 71

39/39

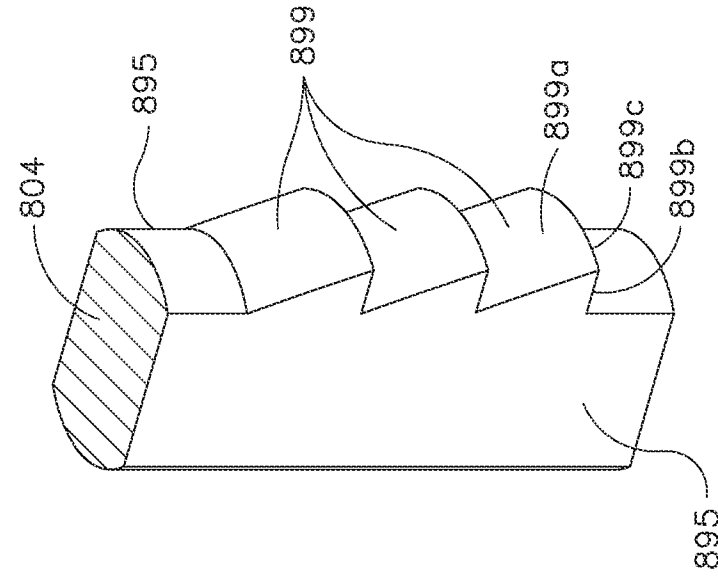

FIG. 72

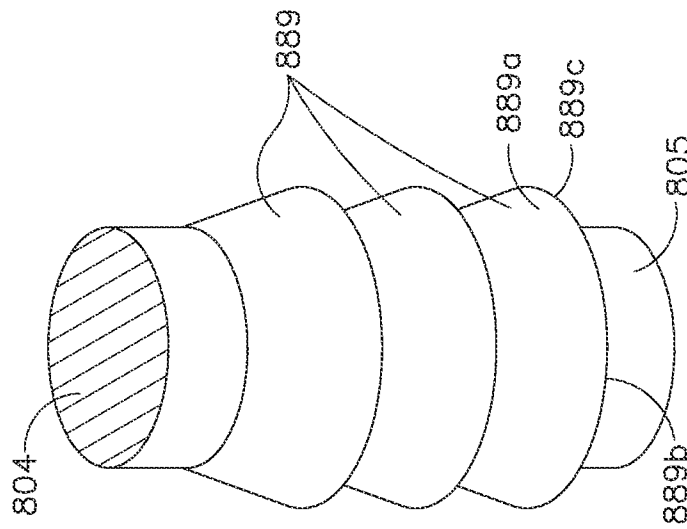

FIG. 73

INTERNATIONAL SEARCH REPORT

International application No
PCT/US2015/012162

A. CLASSIFICATION OF SUBJECT MATTER
INV. A61B17/064 A61B17/072
ADD.
According to International Patent Classification (IPC) or to both national classification and IPC

B. FIELDS SEARCHED
Minimum documentation searched (classification system followed by classification symbols)
A61B
Documentation searched other than minimum documentation to the extent that such documents are included in the fields searched

Electronic data base consulted during the international search (name of data base and, where practicable, search terms used)
EPO-Internal

C. DOCUMENTS CONSIDERED TO BE RELEVANT		
Category*	Citation of document, with indication, where appropriate, of the relevant passages	Relevant to claim No.
X	US 2007/027553 A1 (BIRAN ROY [US] ET AL) 1 February 2007 (2007-02-01)	1,4,5
Y	paragraph [0153]; figures 10A, 10B -----	10
X	US 2012/241492 A1 (SHELTON IV FREDERICK E [US] ET AL) 27 September 2012 (2012-09-27) cited in the application	1,2
A	paragraphs [0470], [0552], [0553]; figures 147-151 -----	12-18
X	US 2002/188170 A1 (SANTAMORE WILLIAM P [US] ET AL) 12 December 2002 (2002-12-12) paragraph [0162]; figure 19E -----	1
X	US 2012/241498 A1 (GONZALEZ HAMILTON E [US] ET AL) 27 September 2012 (2012-09-27) paragraph [0416] -----	1,3
	-/--	

Further documents are listed in the continuation of Box C.

See patent family annex.

* Special categories of cited documents :

<p>"A" document defining the general state of the art which is not considered to be of particular relevance</p> <p>"E" earlier application or patent but published on or after the international filing date</p> <p>"L" document which may throw doubts on priority claim(s) or which is cited to establish the publication date of another citation or other special reason (as specified)</p> <p>"O" document referring to an oral disclosure, use, exhibition or other means</p> <p>"P" document published prior to the international filing date but later than the priority date claimed</p>	<p>"T" later document published after the international filing date or priority date and not in conflict with the application but cited to understand the principle or theory underlying the invention</p> <p>"X" document of particular relevance; the claimed invention cannot be considered novel or cannot be considered to involve an inventive step when the document is taken alone</p> <p>"Y" document of particular relevance; the claimed invention cannot be considered to involve an inventive step when the document is combined with one or more other such documents, such combination being obvious to a person skilled in the art</p> <p>"&" document member of the same patent family</p>
---------------------------------------------------------------------------------------------------------------------------------------------------------------------------------------------------------------------------------------------------------------------------------------------------------------------------------------------------------------------------------------------------------------------------------------------------------------------------------------------------------------------------------------------------------------------------------------------------	-----------------------------------------------------------------------------------------------------------------------------------------------------------------------------------------------------------------------------------------------------------------------------------------------------------------------------------------------------------------------------------------------------------------------------------------------------------------------------------------------------------------------------------------------------------------------------------------------------------------------------------------------------------------------------------------------------------------

Date of the actual completion of the international search 15 July 2015	Date of mailing of the international search report 23/07/2015
-------------------------------------------------------------------------------	----------------------------------------------------------------------

Name and mailing address of the ISA/ European Patent Office, P.B. 5818 Patentlaan 2 NL - 2280 HV Rijswijk Tel. (+31-70) 340-2040, Fax: (+31-70) 340-3016	Authorized officer Fernández Arillo, J
----------------------------------------------------------------------------------------------------------------------------------------------------------------------	-----------------------------------------------

INTERNATIONAL SEARCH REPORT

International application No
PCT/US2015/012162

C(Continuation). DOCUMENTS CONSIDERED TO BE RELEVANT		
Category*	Citation of document, with indication, where appropriate, of the relevant passages	Relevant to claim No.
X	US 2010/191292 A1 (DEMEO JOSEPH [US] ET AL) 29 July 2010 (2010-07-29) paragraphs [0034], [0060] -----	1,3
X Y	EP 2 586 380 A1 (COVIDIEN LP [US]) 1 May 2013 (2013-05-01) paragraphs [0055], [0067], [0068]; figure 5 -----	6-9,11, 19-21 10
X	JP 3 442423 B2 (SEKISUI CHEMICAL CO LTD; DAIICHI SEIYAKU CO; SAITAMA DAIICHI SEIYAKU K) 2 September 2003 (2003-09-02) figures 4, 5 -----	19-21
X,P	US 2014/166726 A1 (SCHELLIN EMILY A [US] ET AL) 19 June 2014 (2014-06-19) the whole document -----	1,2,4,5

INTERNATIONAL SEARCH REPORT

International application No.
PCT/US2015/012162

Box No. II Observations where certain claims were found unsearchable (Continuation of item 2 of first sheet)

This international search report has not been established in respect of certain claims under Article 17(2)(a) for the following reasons:

1. Claims Nos.:
because they relate to subject matter not required to be searched by this Authority, namely:

2. Claims Nos.:
because they relate to parts of the international application that do not comply with the prescribed requirements to such an extent that no meaningful international search can be carried out, specifically:

3. Claims Nos.:
because they are dependent claims and are not drafted in accordance with the second and third sentences of Rule 6.4(a).

Box No. III Observations where unity of invention is lacking (Continuation of item 3 of first sheet)

This International Searching Authority found multiple inventions in this international application, as follows:

see additional sheet

1. As all required additional search fees were timely paid by the applicant, this international search report covers all searchable claims.

2. As all searchable claims could be searched without effort justifying an additional fees, this Authority did not invite payment of additional fees.

3. As only some of the required additional search fees were timely paid by the applicant, this international search report covers only those claims for which fees were paid, specifically claims Nos.:

4. No required additional search fees were timely paid by the applicant. Consequently, this international search report is restricted to the invention first mentioned in the claims; it is covered by claims Nos.:

Remark on Protest

- The additional search fees were accompanied by the applicant's protest and, where applicable, the payment of a protest fee.
- The additional search fees were accompanied by the applicant's protest but the applicable protest fee was not paid within the time limit specified in the invitation.
- No protest accompanied the payment of additional search fees.

FURTHER INFORMATION CONTINUED FROM PCT/ISA/ 210

This International Searching Authority found multiple (groups of) inventions in this international application, as follows:

1. claims: 1, 2, 4, 5

The method of claim 1, wherein the tissue thickness compensator is obtained by dissolving a polymer in a solvent and lyophilizing the solution (claim 2), thereby solving the problem of providing some control over a tissue thickness compensator's porosity (see para. 165).

2. claim: 3

The method of claim 1, wherein the step of manipulating said surface comprises applying a compressive force to said surface (claim 3), thereby solving the problem of reducing the overall volume of the compensator.

3. claims: 6-11

A customized tissue thickness compensator for use with a surgical stapler, wherein a surface of said tissue thickness compensator has been obtained and altered by engaging it with a heated contacting surface of a surface modifier (claim 6), thereby solving the problem of providing the tissue thickness compensator with a skin or a dense outer layer, e.g. the resulting skin or dense outer layer may comprise textures such as protrusions (see para. 142).

4. claims: 12-18

A method for producing a foam, said method comprising the steps of:
dissolving a biocompatible polymer in a solvent,
lyophilizing the solution to produce a foam, heating the foam to a temperature higher than the glass transition temperature; inserting a space creator into said foam (claim 12), thereby solving the problem of providing a simplified method for manufacturing a biocompatible foam for use with a surgical stapler, the foam having a space.

5. claims: 19-21

A method for altering a biocompatible foam, said method comprising the steps of: obtaining a biocompatible foam; heating a space creator to the melting temperature of the foam; inserting the space creator into the foam; allowing the foam to cool (claim 19), thereby solving the problem of easily creating a space in the foam.

INTERNATIONAL SEARCH REPORT

Information on patent family members

International application No

PCT/US2015/012162

Patent document cited in search report	Publication date	Patent family member(s)	Publication date	
US 2007027553	A1	01-02-2007	ES 2537193 T3	03-06-2015
			JP 5275795 B2	28-08-2013
			JP 2009502330 A	29-01-2009
			US 2007027553 A1	01-02-2007
			US 2007027554 A1	01-02-2007
US 2012241492	A1	27-09-2012	EP 2644119 A2	02-10-2013
			EP 2644123 A1	02-10-2013
			EP 2644125 A2	02-10-2013
			EP 2653115 A1	23-10-2013
			US 2012241492 A1	27-09-2012
			US 2013256367 A1	03-10-2013
			US 2013256368 A1	03-10-2013
			US 2013256369 A1	03-10-2013
			US 2013256380 A1	03-10-2013
			WO 2013148766 A2	03-10-2013
			WO 2013148825 A1	03-10-2013
			WO 2013148827 A2	03-10-2013
			WO 2013148828 A2	03-10-2013
US 2002188170	A1	12-12-2002	AU 2002348017 A1	10-11-2003
			CA 2484057 A1	06-11-2003
			EP 1496862 A1	19-01-2005
			US 2002188170 A1	12-12-2002
			US 2005080402 A1	14-04-2005
			US 2012109044 A1	03-05-2012
			US 2015139911 A1	21-05-2015
			WO 03090716 A1	06-11-2003
US 2012241498	A1	27-09-2012	EP 2644109 A2	02-10-2013
			EP 2644110 A1	02-10-2013
			EP 2644111 A2	02-10-2013
			EP 2644117 A1	02-10-2013
			EP 2644212 A1	02-10-2013
			US 2012241493 A1	27-09-2012
			US 2012241498 A1	27-09-2012
			US 2012241500 A1	27-09-2012
			US 2012241501 A1	27-09-2012
			US 2012241502 A1	27-09-2012
			WO 2013148767 A1	03-10-2013
			WO 2013148773 A1	03-10-2013
			WO 2013148779 A2	03-10-2013
			WO 2013148781 A1	03-10-2013
			WO 2013148816 A1	03-10-2013
US 2010191292	A1	29-07-2010	US 2010191292 A1	29-07-2010
			US 2013053850 A1	28-02-2013
EP 2586380	A1	01-05-2013	AU 2012227358 A1	09-05-2013
			CA 2790743 A1	26-04-2013
			EP 2586380 A1	01-05-2013
			US 2013105548 A1	02-05-2013
JP 3442423	B2	02-09-2003	JP 3442423 B2	02-09-2003
			JP H06105857 A	19-04-1994
US 2014166726	A1	19-06-2014	NONE	