



US 20050172425A1

(19) **United States**

(12) **Patent Application Publication**

Hahn et al.

(10) **Pub. No.: US 2005/0172425 A1**

(43) **Pub. Date: Aug. 11, 2005**

(54) **DOCK LEVELER DECK WITH PERMANENTLY VISIBLE LONGITUDINAL GUIDELINE**

(22) Filed: Feb. 11, 2004

Publication Classification

(76) Inventors: **Norbert Hahn**, Franklin, WI (US); **Reinhard E. Sander**, Wauwatosa, WI (US); **Jeffrey R. Schwager**, Mequon, WI (US); **Matt Tourdot**, Whitewater, WI (US)

(51) **Int. Cl.⁷** **E01D 1/00**
(52) **U.S. Cl.** **14/71.1**

(57) **ABSTRACT**

A dock leveler or dock lift deck comprises two upper plates that are connected to create a permanently visible longitudinal joint that serves as a guideline for a forklift operator. In some cases the joint may have a variable width gap that helped in squaring up the deck during manufacturing. To draw attention to the guideline, the two upper plates may each have an embossed pattern that is shifted out of registry with each other.

Correspondence Address:
MARSHALL, GERSTEIN & BORUN LLP
233 S. WACKER DRIVE, SUITE 6300
SEARS TOWER
CHICAGO, IL 60606 (US)

(21) Appl. No.: **10/777,003**

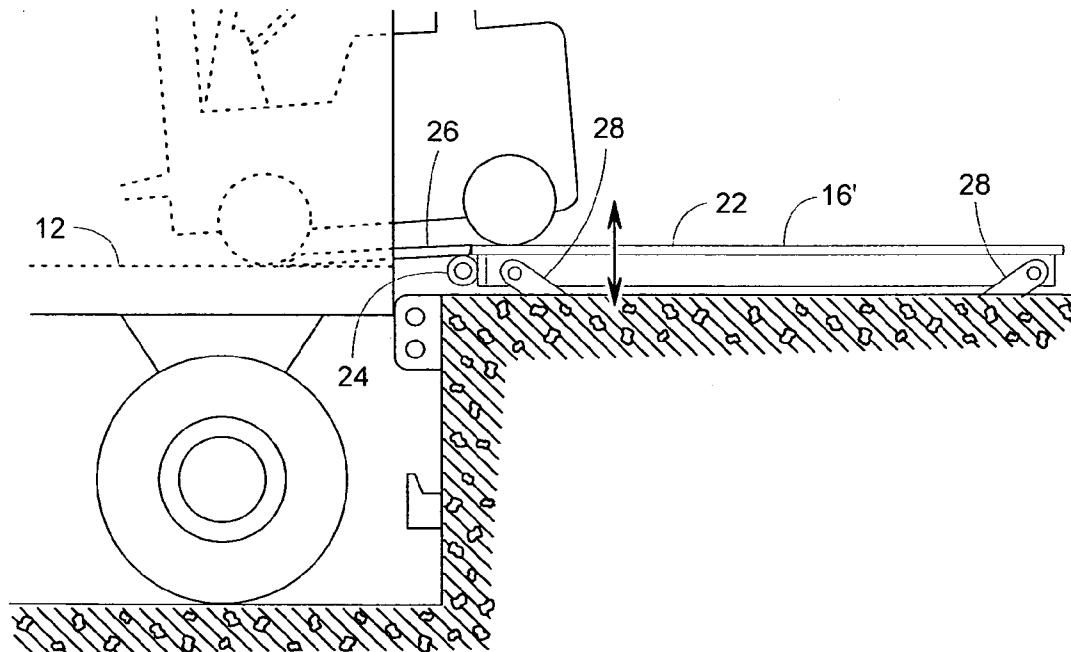
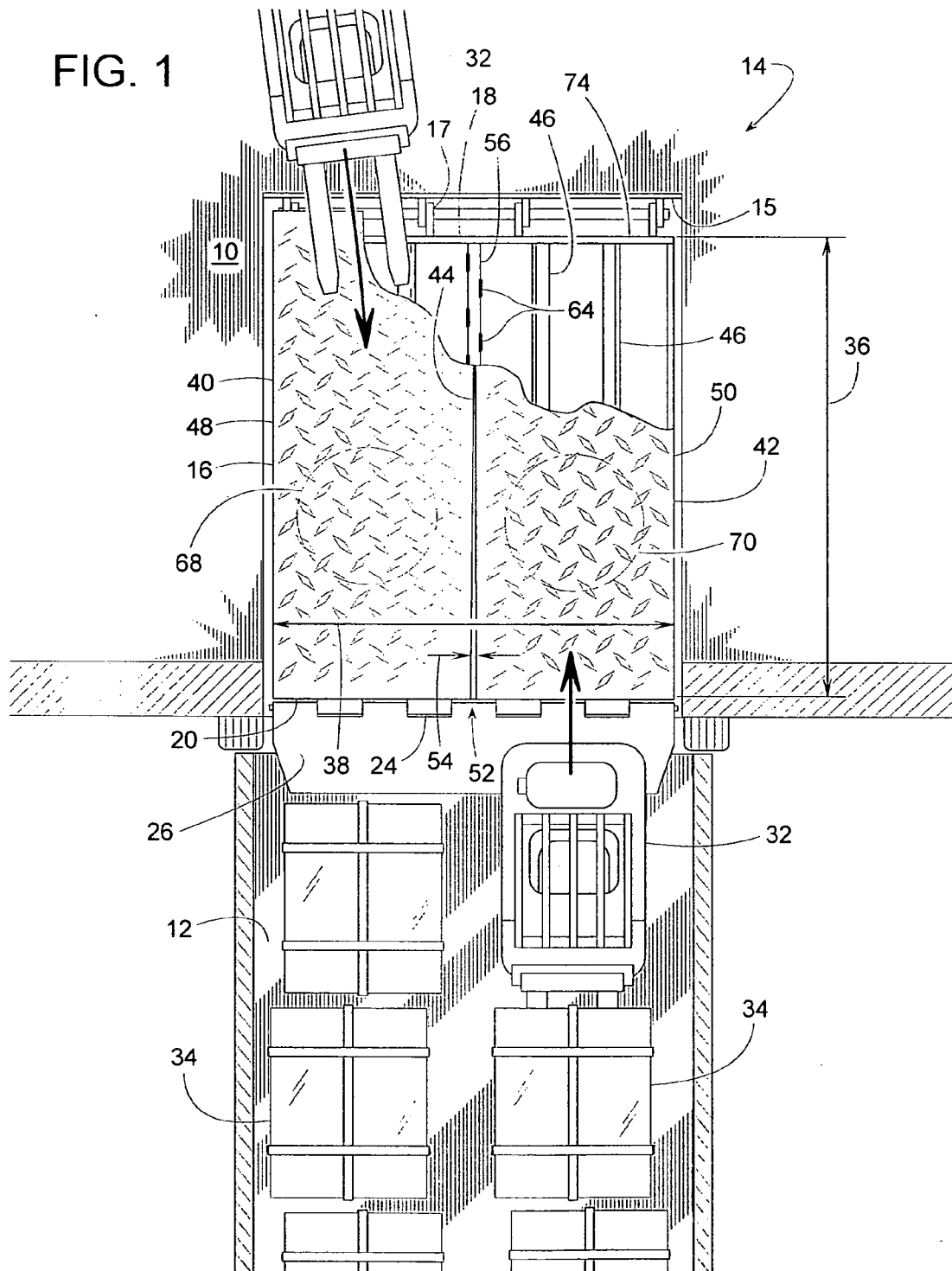

FIG. 1



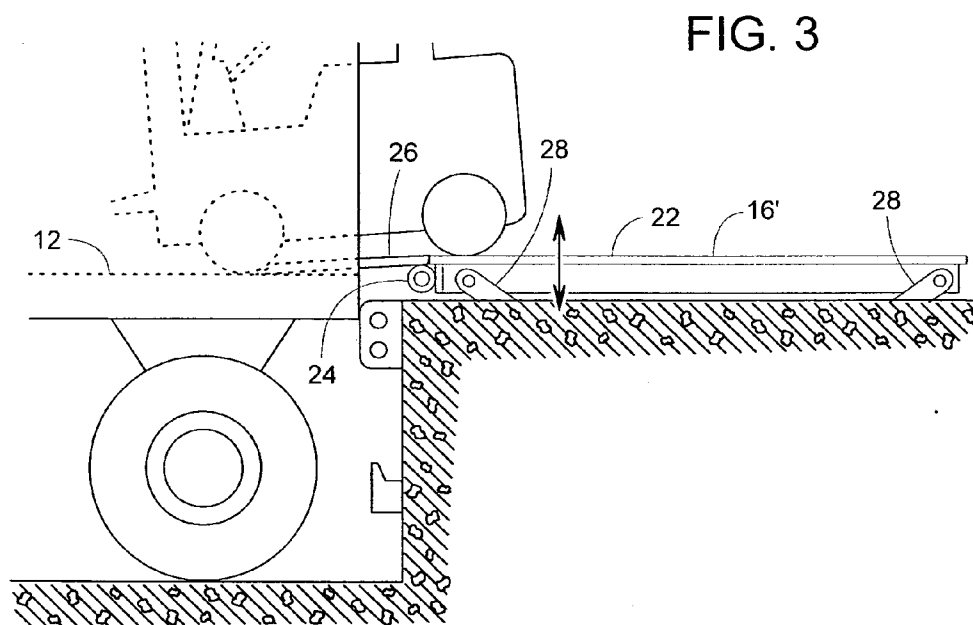
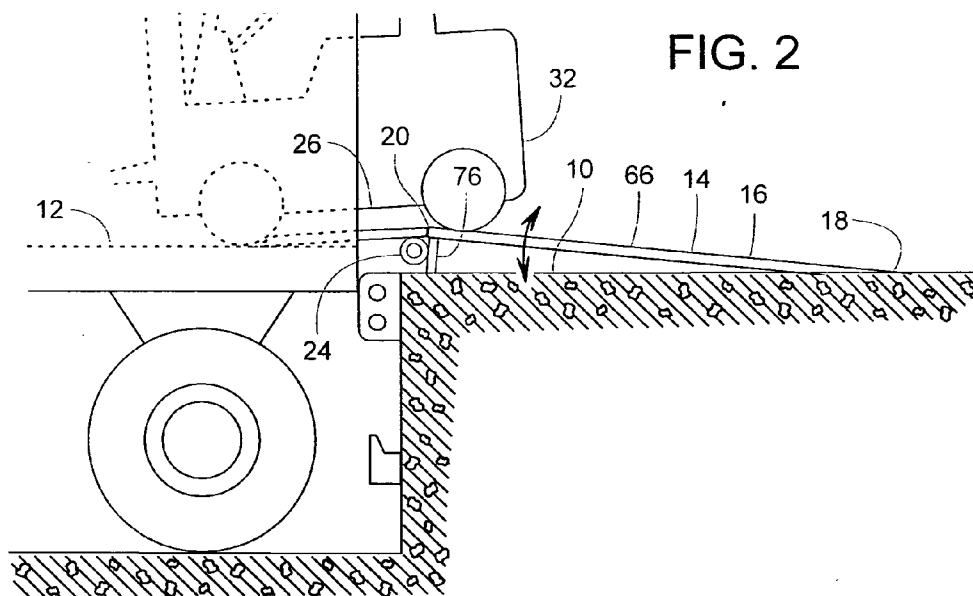

FIG. 4a

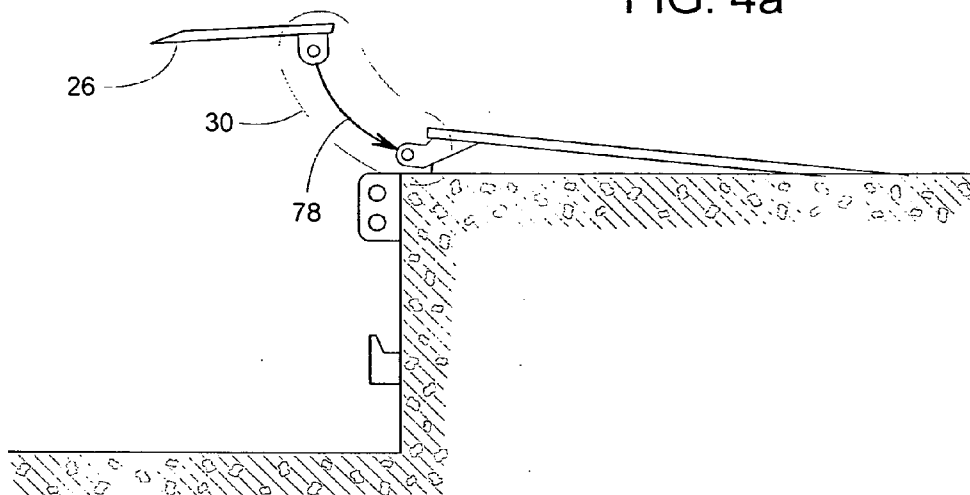

FIG. 4b

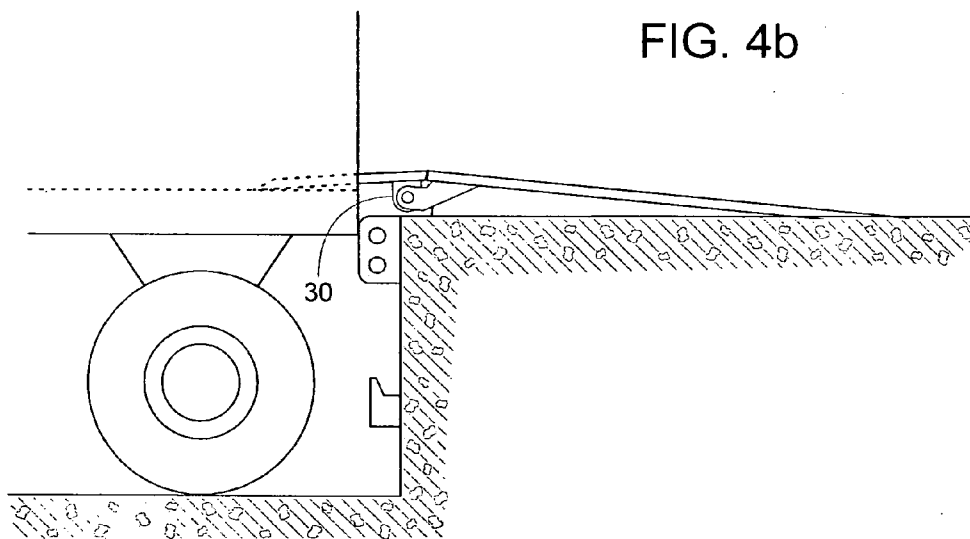

FIG. 5

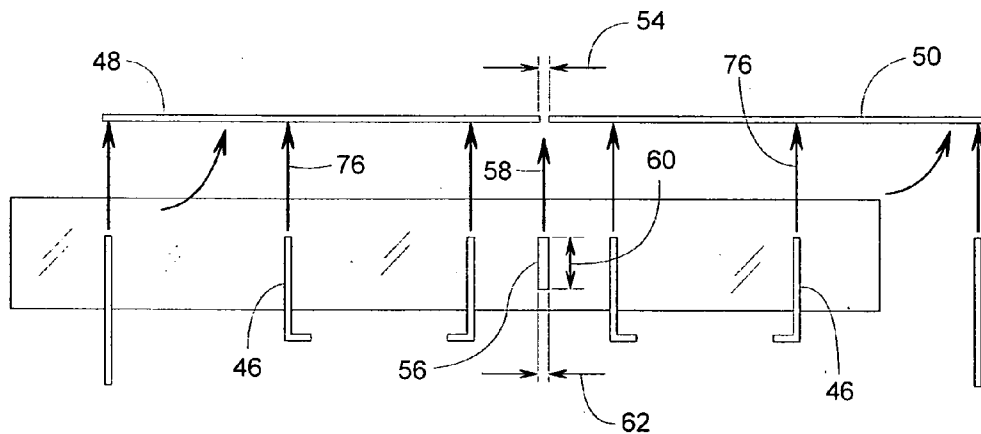
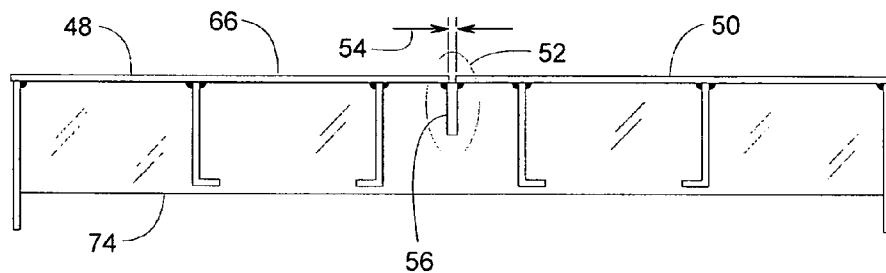

FIG. 6



DOCK LEVELER DECK WITH PERMANENTLY VISIBLE LONGITUDINAL GUIDELINE

BACKGROUND OF THE INVENTION

[0001] 1. Field of the Invention

[0002] The subject invention generally pertains to dock levelers and more specifically to the movable deck of a dock leveler.

[0003] 2. Description of Related Art

[0004] Dock levelers are used to compensate for a height difference that may exist between a loading dock platform and the bed of a truck parked at the dock. A dock leveler system typically includes a deck that is hinged at its back edge or otherwise vertically movable to raise or lower its front edge to generally match the height of the truck bed. Often an extension plate or lip is pivotally coupled to the deck to bridge the gap between the deck's front edge and a back edge of the truck bed. The deck and extended lip provide a path for forklift trucks to travel between the loading dock platform and the truck bed, thus facilitating loading or unloading of the truck.

[0005] In cases where the deck translates vertically rather than pivots, the device is often referred to as a "dock lift." However, since the subject invention can be applied to both dock levelers and dock lifts, the two terms will be considered equivalent and used interchangeably herein.

[0006] Trucking firms, manufacturing plants and warehouses often operate on tight schedules to remain competitive. Thus, it can be important to load and unload delivery trucks as quickly as possible. Often, a single forklift, pallet jack, or other material handling vehicle is used for loading or unloading a truck. To expedite the process, however, sometimes two forklifts may be used for dual-servicing a single truck. Although such a practice is not necessarily recommended, it is done nonetheless.

[0007] The standard width of trucks and common pallet sizes make dual-servicing possible. With a standard truck width of 102-inches, conventional 40"x48" pallets are conveniently loaded in two side-by-side rows that extend the full length of the truck bed. Thus, one forklift can service the row of pallets on the right side of the truck while a second forklift can service the row of pallets on the left side.

[0008] Two forklifts, unfortunately, may interfere with each other if they drift or travel into each other's "lane of traffic." Although the driver of a forklift can use the inside walls of a truck's trailer for guidance when the forklift is inside the trailer, the driver loses much of that reference once the forklift is traveling on the wide open deck of a dock leveler and surrounding dock platform area. Losing a line of reference can be like driving a car on a multi-lane road without visible lines dividing the lanes, which can be disorienting.

[0009] Unfortunately, providing a permanent, clearly visible centerline or some other guideline on the surface of a dock leveler's metal deck is not easily accomplished. Paint is readily worn off by traffic, a raised edge or ridge can interfere with forklifts traversing the deck, and a slot cut into the deck can weaken it. Thus, there is a need for providing a dock leveler deck with a permanently visible guideline that

does not interfere with traffic, is permanently visible, and does not significantly weaken a deck.

SUMMARY OF THE INVENTION

[0010] In some embodiments, the deck of a dock leveler includes a permanently visible longitudinal guideline that is not readily worn off.

[0011] In some embodiments, the guideline is centrally located between lateral edges of the deck.

[0012] In some embodiments, the guideline is offset to the deck's longitudinal centerline.

[0013] In some embodiments, the guideline is created by the joint of a longitudinally split deck.

[0014] In some embodiments, visibility of the dividing line or guideline is enhanced by a shift in a frictional pattern that overlays the deck.

[0015] In some embodiments, a variable width, longitudinal gap between two upper deck plates facilitates squaring up the deck at assembly.

[0016] In some embodiments, two deck plates are joined by an intermittent weld to avoid deck warpage.

[0017] In some embodiments, the welding of two deck plates is confined to one face of the deck to avoid having to flip over a partially welded deck at assembly.

[0018] In some embodiments, the joint between two deck plates is reinforced by a connecting bar that is set on edge so that the bar's width runs perpendicular to the deck plates. In this orientation, the bar minimizes weld distortion and provides extra support for the central wheel of a 3-wheeled material handling vehicle.

[0019] In some embodiments, it becomes easier to handle and ship smaller parts of a multi-plate deck rather than one large deck plate.

[0020] In some embodiments, narrower deck plate segments are more readily available than a single-piece, full-width deck plate.

[0021] In some embodiments, the joint between two deck plates is contained below the top surface of the plates to avoid interference with traffic.

BRIEF DESCRIPTION OF THE DRAWINGS

[0022] **FIG. 1** is a top view of a dock leveler that includes a longitudinal joint, wherein a portion of the top plates is cutaway to show detail underneath the plates.

[0023] **FIG. 2** is a side view of the dock leveler of **FIG. 1**.

[0024] **FIG. 3** is a side view similar to **FIG. 2** but showing a vertically translating dock leveler (dock lift).

[0025] **FIG. 4a** is a side view showing a lip extension plate being attached to the hinge of a dock leveler deck.

[0026] **FIG. 4b** is side view of the lip and deck of **FIG. 4a** but with the lip attached to the deck and the dock leveler in operation.

[0027] FIG. 5 is a front view of a connecting bar, a back plate, and a plurality of support beams being attached to two upper plates of a dock leveler deck.

[0028] FIG. 6 is a front view similar to FIG. 5 but showing the connecting bar, support beams, back plate, and upper plates assembled.

DESCRIPTION OF THE PREFERRED EMBODIMENT

[0029] Referring to FIGS. 1 and 2, in order to compensate for a height difference that may exist between a loading dock platform 10 and a truck bed 12, a dock leveler 14 includes a ramp or deck 16 adapted to be coupled to the loading dock so that deck 16 can pivot or vertically translate relative to the loading dock. Dock leveler 14 may also include a frame 15, which is any individual structure or combination structures that help mount dock leveler 14 within a pit of a loading dock. For pivotal decks, a hinge 17 connects a rear edge 18 of deck 16 to frame 15 or connects edge 18 directly to the pit wall so that pivotal motion of deck 16 can raise or lower a front edge 20 of the deck to generally match the height of truck bed 12. In other cases, as shown in FIG. 3, a dock leveler 22 may be driven by a conventional scissors jack 28 where the entire deck 16' vertically translates rather than pivots. A vertically translating dock leveler is often referred to as a "dock lift." For the purpose of the subject invention, however, the terms "dock leveler" and "dock lift" will be considered equivalent and used interchangeably herein. Thus, a "dock leveler" encompasses both pivotal decks and vertically translating decks. In some cases, a combination translating/pivotal dock leveler, as disclosed in U.S. Pat. No. 4,995,130, includes a deck that selectively pivots or translates.

[0030] Often a hinge 24 pivotally couples an extension plate or lip 26 to deck 16 or 16' so that lip 26 can swing out and rest upon the rear edge of truck bed 12, thus bridging the gap between the deck's front edge 20 and the rear of truck bed 12. The lip hinge can be of any style, such as, for example, the pinned tube arrangement of FIGS. 1 and 2, or a set of pinned lugs 30 as shown in FIGS. 4a and 4b, or some other style of hinge. As an alternative to a hinged pivotal lip, in some cases, the lip is connected for translation relative to deck 16. Together, deck 16 and extended lip 26 provide a path for a forklift truck 32, pallet jack, or other material handling equipment to travel between platform 10 and truck bed 12, thus facilitating the loading and unloading of the truck's cargo such as the two rows of palletized loads 34 shown in FIG. 1.

[0031] Those of ordinary skill in the art will appreciate that there are a myriad of known drive mechanisms for pivoting or translating the deck and lip of a dock leveler. Thus, such mechanisms have not been shown in much detail so that other features can be more clearly illustrated. Examples of such deck or lip drive mechanisms include, but are not limited to, a hydraulic cylinder, pneumatic cylinder, inflatable bag, bellows, spring actuator, drive screw, linear motor, winch, manual actuation, mechanical linkage, cam actuation, and various combinations thereof.

[0032] Regardless of the deck and lip's mode of actuation, deck 16 has a length 36 extending between edges 18 and 20 and has a width 38 extending between two lateral edges 40 and 42. Deck 16 includes a permanently visible guideline 44

that runs longitudinally between front edge 20 to rear edge 18. Guideline 44 provides various benefits including, but not limited to, providing visual guidance to an operator of material handling equipment, such as a forklift 32. Such guidance is particularly helpful when the loads 34 inside the truck are arranged in two rows as shown in FIG. 1.

[0033] To create a durable, visible guideline on the deck without sacrificing the deck's integrity or creating an excessively high raised edge that might interfere with traffic, deck 16 comprises two separate upper plates attached to a plurality of lower support beams 46. A right upper plate 48 and a left upper plate 50 are connected or coupled to create a joint 52 between the two plates. A gap 54 or even a tight interface between the two plates is what provides the visible guideline. The term, "gap," refers to any space between the two plates, wherein the space can be empty or filled with anything other than the plates themselves. It should be noted that even a fine line or a narrow joint can be a valuable guideline.

[0034] Plates 48 and 50 can be joined in any suitable manner. The plates, for instance, can be welded or otherwise fastened directly to each other. For greater strength and deck rigidity, a connecting bar 56 can help join or couple the two plates. Referring to FIGS. 5 and 6, connecting bar 56 can be welded to plates 48 and 50. To minimize weld distortion of the plates and to maximize the plates' rigidity near joint 52, bar 56 is preferably installed on edge. More specifically, bar 56 has a bar length (approximately equal to length 36), a bar width 60 and a bar thickness 62, wherein the bar length extends along the length of joint 52, bar width 60 lies generally perpendicular to plates 48 and 50, and bar thickness 62 extends from plate 48 to plate 50. Bar width 60 is preferably greater than bar thickness 62 because increasing width 60 increases the deck's rigidity. The thickness of bar 62 is preferably sized to be larger than gap 54.

[0035] Reduction in weld distortion can be achieved by using an intermittent weld pattern or a plurality of spaced-apart weld beads 64 to weld bar 56 to plates 48 and 50. Additional welding along joint 52 on an upper driving surface 66 of the plates 48 and 50 may also help reduce weld distortion; however, such a technique may involve the difficult task of having to turn a cumbersome deck over before the deck is completely welded.

[0036] The upper driving surface 66 of plates 48 and 50 may be smooth or may be provided with some type of antifriction coating for greater traction. In some cases, for example, frictional patterns 68 and 70 can be embossed upon the driving surfaces of plates 48 and 50. The patterns can be of any design such as those shown in FIG. 1 where frictional patterns 68 and 70 are a matrix of diamond-shaped protrusions distributed in a herringbone arrangement. Staggering or shifting the patterns out of registry with each other can draw attention to the interface or guideline between the two plates, whereby joint 52 becomes easier to spot. Pattern 68, for example can be offset longitudinally and/or laterally relative to pattern 70, whereby the longitudinal and lateral spacing of adjacent diamonds within a plate is different than the longitudinal and lateral spacing of adjacent diamonds of opposite plates (i.e., the spacing between a diamond on plate 68 and an adjacent diamond on plate 70).

[0037] It should be noted that although joint 52 provides a visible guideline, it also provides manufacturing-related

benefits as well. Two or more smaller upper plates, for instance, are easier to handle during manufacturing and shipping than one large plate. Generally, the larger the plate, the more difficult it is to shear the plate squarely. With two smaller plates rather than one large one, the position of the two plates relative to each other can be set so as to create deck 16 with a proper length, width and perpendicularity. Before welding deck 16 together, the width of gap 54 may be adjusted to vary from one end of the deck to the other to ensure that lateral edges 40 and 42 are parallel to each other. In FIG. 1, for example, gap 54 is wider near front edge 20 and narrower or none existent at rear edge 18, yet lateral edges 40 and 42 are parallel. Likewise, plate 48 may be set farther forward in a longitudinal direction than plate 50 to achieve a desired length or perpendicularity of deck 16. Lastly, smaller plates are more readily available from suppliers than larger ones, whereby competition among suppliers may reduce the material costs of the deck.

[0038] Considering the manufacturing benefits of a longitudinally split deck, joint 52, even though preferred, does not necessarily have to lie midway between lateral edges 40 and 42. Instead, joint 52 may be placed anywhere between edges 40 and 42 and still be beneficial

[0039] To provide deck 16 with additional strength or to facilitate the mounting of hinges 24 or 17, deck 16 may include a back plate 74 and/or a header 76.

[0040] Referring to FIG. 5, arrow 58 represents the steps of connecting plate 48, plate 50 and bar 56 together. Arrow 76 represents the step of fastening a plurality of support beams 46 to plates 48 and 50. Arrow 78 of FIG. 4a represents the step of connecting lip 26 to hinge 30.

[0041] Although the invention is described with reference to the above examples, it should be appreciated by those of ordinary skill in the art that various modifications are well within the scope of the invention. Therefore, the scope of the invention is to be determined by reference to the following claims:

1. A dock leveler for a loading dock, comprising:
a deck adapted to be coupled to the loading dock such that the deck is movable relative thereto; wherein the deck comprises a right upper plate, a left upper plate, and a plurality of lower support beams; wherein the right upper plate and the left upper plate are affixed to the

lower support beams; the deck has a front edge, a rear edge, and two lateral edges; the deck has a deck width that extends between the two lateral edges; the deck has a deck length that extends from the front edge to the rear edge; the deck has a joint between the right upper plate and the left upper plate; the joint extends longitudinally from the front edge to the rear edge of the deck; and the right upper plate and the left upper plate are substantially stationary relative to each other; and

a lip extension plate coupled to the front edge and being movable relative thereto.

2. The dock leveler of claim 1, wherein the joint includes a connecting bar disposed below the right upper plate and the left upper plate.

3. The dock leveler of claim 2, wherein the connecting bar has a bar length, a bar width, and a bar thickness all of which are perpendicular to each other, wherein the bar length runs along the joint, the bar thickness extends from the right upper plate to the left upper plate, and the bar width is greater than the bar thickness.

4. The dock leveler of claim 3, wherein the right upper plate and the left upper plate provide an upper driving surface, wherein the connecting bar is disposed no higher than the upper driving surface.

5. The dock leveler of claim 1, wherein the right upper plate and the left upper plate provide an upper driving surface, and the joint includes a plurality of spaced-apart weld beads that are disposed below the upper driving surface.

6. The dock leveler of claim 1, wherein the joint provides a gap between the right upper plate and the left upper plate.

7. The dock leveler of claim 6, wherein the gap has a variable gap width that is visible.

8. The dock leveler of claim 1, wherein a first frictional pattern exists on top of the right upper plate and second frictional pattern exists on top of the left upper plate, wherein the first frictional pattern is shifted out of registry with the second frictional pattern.

9. The dock leveler of claim 1, wherein the joint is substantially parallel to the plurality of lower support beams.

10. The dock leveler of claim 1, wherein the joint is substantially centrally located between the two lateral edges of the deck.

11-25. (canceled)

* * * * *