

(19) World Intellectual Property Organization  
International Bureau



(43) International Publication Date  
4 June 2009 (04.06.2009)

PCT

(10) International Publication Number  
**WO 2009/068302 A2**

- (51) International Patent Classification:  
*E21B 43/14* (2006.01)     *E21B 49/00* (2006.01)
- (21) International Application Number:  
PCT/EP2008/010119
- (22) International Filing Date:  
28 November 2008 (28.11.2008)
- (25) Filing Language: English
- (26) Publication Language: English
- (30) Priority Data:  
60/991,445     30 November 2007 (30.11.2007)     US
- (71) Applicant (for FR only): **SERVICES PETROLIERS SCHLUMBERGER** [FR/FR]; 42, rue Saint-Dominique, F-75007 Paris (FR).
- (71) Applicant (for GB, JP, NL only): **SCHLUMBERGER HOLDINGS LIMITED**; P.O. Box 71, Craigmuir Chambers, Road Town, Tortola (VG).
- (71) Applicant (for CA only): **SCHLUMBERGER CANADA LIMITED** [CA/CA]; 525-3rd Ave S.W., Calgary, Alberta T2P 0G4 (CA).

- (71) Applicant (for AE, AL, AU, AZ, BG, CO, CZ, DE, DK, GR, HU, ID, IE, IL, IT, KP, KR, KZ, LT, MX, MY, NO, NZ, OM, PL, RO, RU, SI, SK, TM, TN, TR, TT, UA, UZ, ZA only): **SCHLUMBERGER TECHNOLOGY BV** [NL/NL]; Parkstraat 83-89, NL-2514 JG The Hague (NL).
- (71) Applicant (for all designated States except AE, AL, AU, AZ, BG, CA, CO, CZ, DE, DK, FR, GB, GR, HU, ID, IE, IL, IT, JP, KP, KR, KZ, LT, MX, MY, NL, NO, NZ, OM, PL, RO, RU, SI, SK, TM, TN, TR, TT, UA, US, UZ, ZA): **PRAD RESEARCH AND DEVELOPMENT LIMITED**; P.O. Box 71, Craigmuir Chambers, Road Town, Torola (VG).
- (72) Inventors; and
- (75) Inventors/Applicants (for US only): **LE FOLL, Pierre** [FR/FR]; 16, rue des Morteaux, F-92160 Antony (FR). **FILAS, Jim** [US/FR]; 1, rue des Gate Ceps, F-92210 Saint-Cloud (FR). **SARVARI, Christopher** [GB/FR]; 7, allée des Lauriers, F-78450 Chavenay (FR).
- (74) Agents: **OSHA LIANG** et al.; 32 Avenue de l'Opéra, F-75002 Paris (FR).

[Continued on next page]

(54) Title: DOWNHOLE, SINGLE TRIP, MULTI-ZONE TESTING SYSTEM AND DOWNHOLE TESTING METHOD USING SUCH

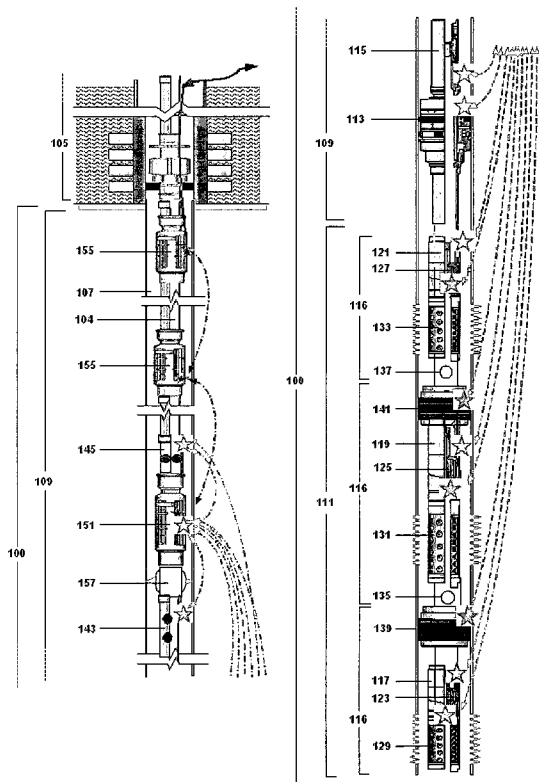

Figure 2

(57) Abstract: A multizone testing system (100), for the testing of subterranean layers, comprises an upper subsystem (109) comprising a control station (151), a main isolation packer (113) for isolating the upper subsystem (109) from the lower subsystem (111), a lower subsystem (111) comprising an array of individual apparatuses (116) connected in series, each apparatus (116) being adapted for the testing of one layer and comprising a series of remotely activated tools for hydraulically isolating and testing the corresponding layer and a communication system comprises communication means between the control station (151) and the surface and between the control station (151) and each of the individual apparatuses (116) in order to control the remotely activated tools of the individual apparatuses for sequential testing of the layers. A multizone testing method for the testing of a plurality of subterranean layers intersected by a well, using a multizone testing system (100) comprises the steps of running and positioning said system (100) into the well such that each individual apparatus (116) is adjacent to a layer to be tested and controlling the remotely activated tools of the individual apparatuses for a sequential test of the layers.

WO 2009/068302 A2



(81) **Designated States** (*unless otherwise indicated, for every kind of national protection available*): AE, AG, AL, AM, AO, AT, AU, AZ, BA, BB, BG, BH, BR, BW, BY, BZ, CA, CH, CN, CO, CR, CU, CZ, DE, DK, DM, DO, DZ, EC, EE, EG, ES, FI, GB, GD, GE, GH, GM, GT, HN, HR, HU, ID, IL, IN, IS, JP, KE, KG, KM, KN, KP, KR, KZ, LA, LC, LK, LR, LS, LT, LU, LY, MA, MD, ME, MG, MK, MN, MW, MX, MY, MZ, NA, NG, NI, NO, NZ, OM, PG, PH, PL, PT, RO, RS, RU, SC, SD, SE, SG, SK, SL, SM, ST, SV, SY, TJ, TM, TN, TR, TT, TZ, UA, UG, US, UZ, VC, VN, ZA, ZM, ZW.

(84) **Designated States** (*unless otherwise indicated, for every kind of regional protection available*): ARIPO (BW, GH,

GM, KE, LS, MW, MZ, NA, SD, SL, SZ, TZ, UG, ZM, ZW), Eurasian (AM, AZ, BY, KG, KZ, MD, RU, TJ, TM), European (AT, BE, BG, CH, CY, CZ, DE, DK, EE, ES, FI, FR, GB, GR, HR, HU, IE, IS, IT, LT, LU, LV, MC, MT, NL, NO, PL, PT, RO, SE, SI, SK, TR), OAPI (BF, BJ, CF, CG, CI, CM, GA, GN, GQ, GW, ML, MR, NE, SN, TD, TG).

**Published:**

— *without international search report and to be republished upon receipt of that report*

# DOWNHOLE, SINGLE TRIP, MULTI-ZONE TESTING SYSTEM AND DOWNHOLE TESTING METHOD USING SUCH

## BACKGROUND OF INVENTION

### Field of the Invention

[0001] The invention relates to downhole well testing which is a broad term to designate methods to evaluate subterranean rock layers intersected by a well for their potential to produce hydrocarbons.

### Description of the prior art

[0002] Downhole well testing consists in lowering an apparatus or combination of apparatuses in the well in order to hydraulically isolate the layer of interest from the rest of the well and enable that layer to either flow into a chamber that is part of the combination of apparatuses or to flow to surface via suitable pipes that are connected to the apparatuses.

[0003] After a wellbore has been drilled through the formation, the various layers of the formation are perforated using perforating guns. Following perforation, testing, such as drillstem testing, is performed. Drillstem testing (DST) is a procedure to determine the productive capacity, pressure, permeability and nature of the reservoir fluids, or extent (or some combination of these characteristics) of a hydrocarbon reservoir in each layer of the formation.

[0004] In the field of oil and gas well testing, it is common to encounter wells that traverse more than one separate subterranean hydrocarbon bearing zones which may have similar or different characteristics.

[0005] In this event, it is today necessary to perform as many Drill Stem Test (DST) trips in the well as there are layers to be tested. This is a source of considerable non-productive time for a drill stem downhole testing operations.

[0006] Currently when several layers that are intersected by a given well are to be tested, a separate downhole test is performed on each layer, sequentially starting from the

bottom of the well, using a drillstem testing tool (DST tool) also called a test string. At the end of each test, said test string is removed from the well to enable the layer that was just tested to be hydraulically isolated from the well and the test tools to be reset for the next run of the string in the well.

**[0007]** A typical sequence deployed to test two zones in a given well with a downhole testing system according to the prior art is illustrated in Figures 1a to 1f.

**[0008]** As shown in Figure 1a, the test string 3 comprising a packer 7, a perforating gun system 9 and a tester valve 13 is run into the well 5 in order to position the perforating gun system 9 adjacent to the lowest layer of interest 1. Packer 7 is set to isolate layer 1 from the well bore 5. The layer 1 is then perforated with the perforating gun 9, as shown on Figure 1b. Accordingly, the layer material 11 flows into the well bore 5 and inside the test string 3 and is tested. For example, pressure is measured and sampling of layer material is performed via pressure gauges and samplers typically positioned below the tester valve 13. The layer 1 is then killed, packer 7 is unset and the test string 3 is pulled from the well 5. Layer 1 is isolated from the upper part of the well bore 5 by setting a plug 15 across or above it (Figure 1c). The test string 3 is reset and the perforating gun 9 is prepared for the test of the following layer 2. As illustrated on Figure 1d, the test string 3 is run again into the well 5 to test the layer 2. Packer 7 is set to isolate layer 2 from the well bore 5. The layer 2 is perforated with the perforating gun 9 (Figure 1e). Layer material 17 flows in the well bore 5 and in the test string 3 and is tested. Once again, pressure may be measured and sampling of layer material may be performed via pressure gauges and samplers positioned below the tester valve 13. Layer 2 is then killed, packer 7 is unset and the test string 3 is pulled from the well 5. On Figure 1f, layer 2 is isolated from the upper part of the well bore 5 by setting a plug 19 across or above it. Successively, all additional layers of the well 5 may be tested in the same way.

**[0009]** In the system as described above, the test string 3 needs to be removed for each layer to be tested, for the test string 3 to be reset and a plug to be set. As a result, the downhole testing of multiple layers in a wellbore may be a lengthy and costly process.

It may take up to several days which may be costly in terms of labor and equipment costs and which delays the completion of a wellbore.

[0010] An example of a multizone testing system is disclosed in U.S. Patent Application No. 2006/0207764. This application relates to an assembly enabling a plurality of layers of interest to be sequentially tested. Said assembly comprises a plurality of valves, each being actuatable by dropping a valve-actuating object into the corresponding valve. The valves are successively actuatable to an open state in a predetermined sequence and the different layers are tested or stimulated after actuating corresponding valves to the open state.

[0011] The document mentioned above describes a downhole testing system principally related to the stimulation of the layers. Once actuated, the valves cannot be closed. Accordingly, it doesn't provide any flexibility in the testing of the layers.

[0012] The system of the present invention solves the above-mentioned problems by providing a testing system which may be used to test several layers within a single trip of the downhole test string in the well and which provides flexibility in the testing of the layers.

### SUMMARY OF INVENTION

[0013] According to a first aspect, the invention relates to a multizone testing system, for the testing of subterranean layers, comprising an upper subsystem comprising a control station and a main isolation packer for isolating the upper subsystem from the lower subsystem, a lower subsystem comprising an array of individual apparatuses connected in series, each apparatus being adapted for the testing of one layer and comprising a series of remotely activated tools for hydraulically isolating and testing the corresponding layer. It further comprises a communication system comprising communication means between the control station and the surface and between the control station and each of the individual apparatuses in order to control the remotely activated tools of the individual apparatuses for sequential testing of the layers. The communication system also retrieves data collected by the various tools to the surface.

**[0014]** According to a second aspect, the invention relates to a multizone testing method, for the testing of a plurality of subterranean layers intersected by a well, using a multizone testing system according to the first aspect of the present invention, comprising the steps of running and positioning said system into the well such that each individual apparatus is adjacent to a layer to be tested and controlling the remotely activated tools of the individual apparatuses for a sequential test of the layers.

**[0015]** Other aspects and advantages of the invention will be apparent from the following detailed description and the appended claims.

### BRIEF DESCRIPTION OF DRAWINGS

**[0016]** Figures 1a to 1f illustrate conventional testing sequences from the prior art (already described).

**[0017]** Figure 2 shows a system according to one embodiment of the present invention positioned in the well bore.

**[0018]** Figure 3 shows a system according to one embodiment of the present invention.

**[0019]** Figures 4a to 4c illustrate the sequential multi-zone testing using the system according to one embodiment of the present invention.

**[0020]** Figures 5a and 5b illustrate the sequential multi-zone testing using the system according to another embodiment of the present invention.

**[0021]** Figures 6a to 6c illustrate the sequential multi-zone testing using the system according to another embodiment of the present invention.

**[0022]** Figures 7a to 7d show a table summarizing the states of the different valves (open or closed state) and the different pressure measurements made during a sequential multi-zone testing using a system according to one embodiment of the present invention.

## DETAILED DESCRIPTION OF THE INVENTION

**[0023]** Exemplary embodiments of the invention will now be described in detail with reference to the accompanying figures, in which like elements may be denoted by like reference numerals for consistency.

**[0024]** In the following description, the terms “up” and “down”, “upper” and “lower”, “above” and “below” and other like terms indicating relative positions above or below a given point or element are used to more clearly describe some embodiments of the invention. However, when applied to equipment or methods for use in wells that are deviated or horizontal, such terms may refer to a left to right, right to left, or other relationship as appropriate.

**[0025]** Referring now to the figures and more particularly to Figures 2 to 6, the downhole, single trip, multi-zone testing system of the present invention is shown and generally designated by numeral 100.

**[0026]** System 100 is designed for use in a well 107 and is equipped with an inner tubing 104 in which the layers' material may flow. Typically, well 107 will have a plurality of well formations or layers of interest, such as designated by numerals 101, 102 and 103 (Figures 4 and 6). The exact configuration of wells may vary, of course, and additional formations or layers may be present. For purposes of description, only three layers of interest 101-103 are shown but it is understood that the present invention has application to isolate and test any number of layers in a well.

**[0027]** As shown on Figure 2, the downhole multizone testing system 100 comprises two subsystems, an upper subsystem 109 and a lower subsystem 111.

**[0028]** In the example embodiment of Figure 2, the upper subsystem 109 comprises a control station 151 and a main isolation packer 113 for isolating the upper subsystem 109 from the lower subsystem 111. It further comprises a main valve 115 that serves to permit or to prevent the flow of layer material from the lower subsystem 111 to the upper subsystem 109. This main valve 115 may be for example a dual-valve, made of a sleeve valve and a ball valve such as Schlumberger IRIS valves which are described in

and claimed in US patents 4,971,160, 5,050,675, 5,691,712, 4,796,669, 4,856,595, 4,915,168 and 4,896,722 assigned to Schlumberger and which are incorporated herein by reference for all purposes. The system further comprises a remotely controllable fluid analyzer 143, for analyzing the composition of each individual layer 101-103, a remotely controllable flow meter 145, for measuring the flow of the layers 101-103, individually or commingled. According to this example, the upper subsystem 109 further comprises a remotely controllable back-up pressure gauge and a remotely controllable sampler carrier (not shown in the Figures).

**[0029]** The lower subsystem 111, located below the main packer 113, comprises an array of individual apparatuses 116 connected in series, each apparatus 116 being adapted for the testing of one layer and comprising a series of remotely activated tools for hydraulically isolating and testing the corresponding layer.

**[0030]** Under operation, the downhole multizone testing system 100 is run and positioned into the well such that each individual apparatus is adjacent to a layer to be tested.

**[0031]** In the example embodiments illustrated on Figures 2 and 4a to 4c, the remotely activated tools of each individual apparatus 116 comprise a perforating gun system 129, 131, 133 used to perforate the well 107 in the zone adjacent to a layer 101-103, a flow port 135, 137 enabling layer material to flow from the inner tubing 104 of the system 100 into the well case 107. The remotely activated tools further comprise a tester valve 117, 119, 121 to hydraulically isolate the corresponding layer 101-103, an isolation packer 139, 141 for isolating one layer from another adjacent one and testing means.

**[0032]** The testing means advantageously comprise a pressure gauge 123, 125, 127, and a sampling device (not shown in the Figures) to allow the sampling of the tested layer's material.

**[0033]** The tester valves 117, 119, 121 may be remotely controlled to an open or shut-in state and are used to hydraulically isolate the corresponding layers 101-103. The valves 117, 119, 121 allow the layer 101-103 to flow from the well 107 to the upper part of the testing system 100 via the inner tubing 104 of the system 100. In the



embodiments shown on Figures 2, 4a to 4c, and 5a and 5b, the tester valves 117, 119, 121 are sleeve valves.

**[0034]** The packers 139, 141, when set, are used to isolate the different layers 101-103 of the well 107. They enable each zone of interest 101-103 to be independently and individually perforated using the perforating gun systems 129, 131, 133 and tested by, for example, pressure measurements and sampling of the layers material.

**[0035]** Figure 3 describes in more details the communication system of a multizone testing system, according to a preferred embodiment. It comprises communication means between the control station 151 and the surface 105, and between the control station 151 and each of the individual apparatuses 116 in order to control the remotely activated tools of the individual apparatuses 116 for sequential testing of the layers 101-103. It may also include communication means between the individual apparatuses 116.

**[0036]** According to one aspect of the present invention, the control station 151 is a wireless control station and is equipped with a control station antenna 157 (Figure 2) enabling the wireless signal to be captured and emitted.

**[0037]** In another preferred embodiment, communication means between the control station 151 and the surface 105 comprise one or more repeaters 155 to relay the wireless communication between the control station 151 and the surface 105.

**[0038]** In a preferred embodiment, the communication means comprise a long hop link 147 that takes care of the global communication between the surface 105 and the control station 151. Depending on the well characteristics, the long hop link 147 may also include one or more repeaters 155 to relay the communication. The long hop link 147 may be for example an electromagnetic link.

**[0039]** The communication means between the individual apparatuses 116 and between the control station 151, and between the individual apparatuses 116 comprise a short hop link 149, advantageously an acoustic link.

**[0040]** Generally speaking, the communication system enables tool status and data obtained downhole to be conveyed in real time or near real time to surface 105 as well

as sending, from surface 105, activation commands to the tools and receiving back a confirmation that the commands have been properly executed.

**[0041]** On Figure 2, different communication signals from, for example, the individual tools 116, the flow meter 145, the fluid analyzer 143 to the station 151 and from the station 151 to the surface 105 via repeaters 155 are represented by discontinuous double arrows.

**[0042]** Figures 5a and 5b describe a system 100 substantially similar to the system described in reference to Figures 2 and 4a to 4c but in which the perforating guns 123, 131, 133 are positioned alongside the inner tubing 104 as opposed to being integral to the inner tubing 104. In this embodiment, each individual apparatus 116 further comprises a "Y-block" 504 which splits the inner tubing 104 into two paths: a main path in which the layer's material will flow and a derivative path 505 in which the perforating guns 129, 131, 133 are positioned. The perforating guns 129, 131, 133 are thus positioned in a derivative path 505 branching off from an inner tubing 104 of the system 100 in which the layers' material may flow. A blind sub 506, placed in the derivative path, above the side-mounted perforating gun 129, 131, 133, maintains the sealing integrity of the inner tubing 104.

**[0043]** Figures 6a to 6c describe a system 100 substantially similar to the system described in reference to Figures 2 and 4a to 4c but in which the tester sleeve valves 117, 119, 121 are replaced by tester ball valves 517, 519. In this embodiment of the present invention, each individual apparatus 116 comprises a first flow port 135, 137 enabling layer material to flow from the inner tubing 104 of the system 100 into the well case 107 and a second flow port 134, 136, 138 enabling layer material to flow from the well case 107 into the inner tubing 104 of the system 100. Further, one with skill in the art would appreciate that the tester sleeve valves 117, 119, 121 of the system described in Figures 5a and 5b may also be replaced by tester ball valves.

**[0044]** The multizone testing system described enables the various layers to be tested individually and sequentially, starting from the bottom, as well as commingled, as it is described now.

**[0045]** According to a second aspect, the present invention concerns a multizone testing method for the testing of a plurality of subterranean layers 101-103 intersected by a well 107, using a multizone testing system 100 as described above. The method comprises the steps of:

- (a) running and positioning said system 100 in the well 107 such that each individual apparatus 116 is adjacent to a layer 101-103 to be tested;
- (b) controlling the remotely activated tools of the individual apparatuses 116 for a sequential test of the layers 101-103.

**[0046]** In a preferred embodiment, and in reference to the multizone testing system 100 described above as shown on Figures 2 to 6, step (b) comprises the following steps:

- (b1) setting the packers 113, 139, 141;
  - (b2) keeping all the valves open 115, 117, 119, 121;
  - (b3) perforating the first layer of interest 101 using the perforating gun system 129 of the first individual tool 116 adjacent to said first layer 101;
  - (b4) testing the flow 159 of the first layer 101;
  - (b5) closing the tester valve 117 of the first individual tool 116;
  - (b6) keeping all the valves 115, 119, 121 open except the ones of the layers already tested 117;
- and repeating steps (b3) to (b6) for the testing of each layer 102-103.

**[0047]** In preferred embodiments, step (b) may comprise one of all of the following steps:

- measuring the pressure of the flow 159 using the pressure gauge 123, 125, 127;
- collecting samples of the corresponding tested layer material using the sample carrier;
- analyzing the corresponding tested layer material 157 with the fluid analyzer 143 of the upper subsystem 109;
- measuring the flow of the corresponding tested layer material 159 with the flow meter 145 of the upper subsystem 109.

**[0048]** According to the method, the testing of the pressure build up for each of the layer 101-103 is also possible. For example, after the closing of the tester valve 117 of the

first individual tool 116, said testing is achieved using the pressure gauge 123 of the first individual tool 116 (step b4').

**[0049]** In yet another preferred embodiment, the method also comprises the testing of the commingled flow and commingled pressure build-up. Testing of the commingled flow may be achieved for example by:

(b8) reopening all the tester valves 117, 119, 121;

(b9) measuring the commingled flow using the flow meter 145 and/or measuring the pressure of said commingled flow using the backup pressure gauge and/or the pressure gauges 123, 125, 127 of the individual apparatuses 116.

**[0050]** Testing of the commingled pressure build-up may be achieved for example by :

(b10) closing the main dual-valve 115 of the upper subsystem 109;

(b11) measuring the commingled pressure build-up using the backup pressure gauge and/or the pressure gauges 123, 125, 127 of the individual apparatuses 116.

**[0051]** The same method may be applied using a system 100 in which each individual apparatus 116 further comprises a "Y-block" 504 which splits the inner tubing 104 into two paths: a main path in which the layer's material will flow and a derivative path 505 in which the perforating guns 129, 131, 133 are positioned.

**[0052]** The same method may further be applied using a system 100 where the tester sleeve valves 117, 119, 121 are replaced by tester ball valves 517, 519.

**[0053]** The method is now described in more details according to exemplary embodiments and with references to Figures 4, 5, 6 and 7.

**[0054]** As shown on Figures 4a and 7a, the lower layer of interest 101 is first perforated via the first-layer perforating gun system 129. Layer material 157 is flowed (the flow is schematically represented by the arrow 159) through the open first-layer tester valve 117 into the inner tubing 104 of the testing system 100. It goes up through the first-layer isolation packer 139 before exiting, via the second-layer flow port 135, in the well

bore's 107 zone adjacent to the second layer 102. The flow 159 then goes back into the inner tubing 104 of the testing system 100 via the open second-layer tester valve 119. Then it goes through the second-layer isolation packer 141 and back into the well bore's 107 zone adjacent to the third layer 103 via the third-layer flow port 137. It finally goes back again into the inner tubing 104 of the testing system 100 via the open third-layer tester valve 121 and so on up to the upper part 109 of the testing system 100 above the main packer 113.

**[0055]** During the flow period (159), the first layer 101 is tested. For example, pressure, L1Fl, is measured by the first-layer pressure gauge 123 and layer material 157 is sampled by the sampler carrier and/or analyzed by the fluid analyzer 143.

**[0056]** At the end of the flow period (159), the first-layer tester valve 117 is actuated close via the wireless communication system to record the bottom hole pressure build-up, L1Bup, using the first-layer pressure gauge 123.

**[0057]** Once this is completed, and while maintaining the first-layer tester valve 117 closed, the next layer of interest 102 up the well 107 is perforated with the second-layer perforating gun system 131 and layer material 161 is flowed (163) into the inner tubing 104 of the testing system 100 through the open second-layer tester valve 119, as shown on Figures 4b and 7b. Then it goes up through the second-layer isolation packer 141 before exiting in the well bore 107 via the third-layer flow port 137. It finally goes back into the inner tubing 104 of the testing system 100 via the open third-layer tester valve 121 and so on up to the upper part 109 of the string 105 above the main packer 113.

**[0058]** During the flow period (163), the layer 102 is tested. For example, pressure, L2Fl, is measured by the second-layer pressure gauge 127 and layer material 161 is sampled by the sampler carrier and/or analyzed by the fluid analyzer 143.

**[0059]** Further, as the first-layer tester valve 117 is maintained closed, the build-up pressure of the first layer 101 may be measured using the first-layer pressure gauge 123, which enables to test the effect of the flow 163 of the second layer 102 on the pressure

build-up of the first layer and to detect if there is communication or leak between the two layers 101 and 102 (interference test).

**[0060]** At the end of the flow period (163), the second-layer tester valve 119 is actuated close via the wireless communication system to record the bottom hole pressure build-up, L2Bup, using the second-layer pressure gauge 127.

**[0061]** Finally, as shown on Figures 4c and 7c, while maintaining the first-layer and second-layer tester valves 117, 119 closed, the third layer of interest 103 is perforated with the third-layer perforating gun system 133 and layer material 165 is flowed (167) into the inner tubing 104 of the testing system 100 via the open third-layer tester valve 121. It then goes up to the upper part 109 of the testing system 100 above the main packer 113.

**[0062]** During the flow period (167), the layer 103 is tested the same way as the previous layers. For example, pressure, L3Fl, is measured by the third-layer pressure gauge 127 and layer material is sampled by the sampler carrier and/or analyzed by the fluid analyzer 143.

**[0063]** Once again, interference tests may be performed, to measure the effect of the flow of the third layer on the build-up of the first and second layers, using the pressure gauges 123, 125 and while maintaining the first-layer and second-layer tester valves 117, 119 closed, in order to detect if there is communication or leak between the layers 101-103.

**[0064]** At the end of the third flow period 167, the third-layer tester valve 121 is actuated close via the wireless communication system to record the bottom hole pressure build-up, L3Bup, using the third-layer pressure gauge 127.

**[0065]** The same method is repeated for any additional layer that needs to be tested in the well 107.

**[0066]** Once all layers have been tested individually (flow and pressure build-up), all lower tester valves 117, 121, 123 may be reopened to allow all layers to flow commingled. A final global pressure build-up may be recorded by closing the main

dual valve 115, as shown on Figure 7d. For example, the commingled flow pressure, CFl, is measured by any of the pressure gauges 123, 125, 127 and/or by the back-up pressure gauge. The final global pressure build-up, CBup, may be recorded by any of the pressure gauges 123, 125, 127.

**[0067]** We describe now an example of the method according to the invention with reference to Figures 5a and 5b. The method is adapted to a system 100 as described previously but further comprising a "Y-block" 504 which splits the inner tubing 104 into two paths: a main path in which the layer's material will flow and a derivative path 505 in which the perforating guns 129, 131, 133 are positioned. Figures 5a and 5b represent the method being applied only to one layer of interest 102. The same description may be applied to any other layer of interest.

**[0068]** One layer below the layer of interest 102 has already been perforated and layer material 157 is flowing (159) in the inner tubing 104, as shown on Figure 5a. The layer 102 is perforated via the layer perforating gun system 131. Then, layer material 161 is flowed (163) in the well case 107 around the perforating gun 131 and up into the inner tubing 104 through the open sleeve valve 119, and then up to the next individual apparatus 116 or to the surface, as shown on Figure 5b.

**[0069]** We describe now an example of the method according to the invention with reference to Figures 6a to 6c. The method is adapted to the use of tester ball valves 517, 519.

**[0070]** The first layer 101 is perforated the same way as previously explained. Then, layer material 157 is flowed (159) through the first-layer flow port 134 into the inner tubing 104 of the testing system 100. It goes up through the first-layer isolation packer 139 and through the open first-layer tester valve 117. It then exits, via the lower second-layer flow port 135, in the well bore's 107 zone adjacent to the second layer 102. The flow 159 then goes back into the inner tubing 104 of the testing system 100 via the upper second-layer flow port 136, goes through the second-layer isolation packer 141 and through the open second-layer tester valve 119. It then goes back into the well bore's 107 zone adjacent to the third layer 103 via the lower third-layer flow port 137.

It finally goes back again into the inner tubing 104 of the testing system 100 via the upper third-layer flow port 138 and so on up to the upper part 109 of the testing system 100 above the main packer 113.

**[0071]** The flows 163, 167 of the layer material 161, 165 of all the other layers 102, 103 to be tested follow the same path as the flow 159 of the first layer 101 starting from the well bore's 107 zone adjacent to the tested layer.

**[0072]** The system according to the invention further enables to convey the data from the testing means of the individual apparatuses to the station in real time using the wireless communication means.

**[0073]** While the invention is described in relation to preferred embodiments and examples, numerous changes and modifications may be made by those skilled in the art regarding parts of the downhole multi-zone testing system and steps of the testing method without departing from the scope of the invention. The advantages of the downhole multi-zone testing system and method as described above include, among others :

**[0074]** Time saving as several zones may be tested individually and together within a single trip in the well of test system.

**[0075]** The data may be accessed in real-time from surface via the wireless communication system.

**[0076]** The status of any given apparatus is accessible in real-time from surface via the wireless communication system.

**[0077]** The various apparatuses may be activated at will from surface via the wireless communication system.

**[0078]** The build-up on the lower zones may be extended whilst testing the layers located above.

**[0079]** Sequential interference tests may be performed between an active (flowing) layer and any shut-in layer located below.



**[0080]** Under ideal conditions of zonal isolation, further time gains may be obtained by starting to flow one layer as soon as the previous one has been shut-in.

**[0081]** In an alternative embodiment, communication between the control station and the surface may also be accomplished by an electrical cable. Many variations of the present invention may be readily envisioned by a person skilled in this art without departing from the scope of the present invention as it is defined in the appended claims.

## CLAIMS

1. A multizone testing system (100), for the testing of subterranean layers in a well (107), comprising an upper subsystem (109), a lower subsystem (111) and a communication system, wherein :
  - the upper subsystem (109) comprises
    - a control station (151),
    - a main isolation packer (113) for isolating the upper subsystem from the lower subsystem;
  - the lower subsystem (111) comprises an array of individual apparatuses (116) connected in series, each apparatus (116) being adapted for the testing of one layer (101-103) and comprising a series of remotely activated tools for hydraulically isolating and testing the corresponding layer; and
  - the communication system comprises communication means between the control station (151) and the surface and between the control station (151) and each of the individual apparatuses (116) in order to control the remotely activated tools of the individual apparatuses for sequential testing of the layers.
2. A system according to claim 1, wherein the remotely activated tools comprise a tester valve that may be remotely controlled to an open or shut-in state.
3. A system according to claim 2, wherein the tester valve is a sleeve valve (117, 121, 123).
4. A system according to claim 2, wherein the tester valve is a ball valve (517, 521).
5. A system according to any of the preceding claims, wherein the remotely activated tools comprise remotely controllable testing means.
6. A system according to claim 5, wherein the remotely controllable testing means comprise a remotely controllable pressure gauge (123, 125, 127).
7. A system according to claim 5 or 6, wherein the remotely controllable testing means comprise a remotely controllable sampling device.

8. A system according to any of the preceding claims, wherein the remotely activated tools comprise a remotely activated packer (139, 141) for isolating one layer from another adjacent one.
9. A system according to any of the preceding claims, wherein the remotely activated tools comprise a remotely activated perforating gun system (129, 131, 133) used to perforate the well (107) in the zone adjacent to the corresponding layer (101-103).
10. A system according to claim 9, wherein the remotely activated perforating gun system (129, 131, 133) is positioned in a derivative path (505) branching off from an inner tubing (104) of the system (100) in which the layers' material may flow.
11. A system according to any of the preceding claims, wherein each individual apparatus (116) comprises a flow port (135, 137) enabling layer material to flow from the well case (107) into an inner tubing (104) of the system (100).
12. A system according to any of the preceding claims, wherein each individual apparatus (116) comprises a flow port (134, 136, 138) enabling layer material to flow from the inner tubing (104) of the system (100) into the well case (107).
13. A system according to any of the preceding claims, wherein the upper subsystem (109) comprise a main valve (115).
14. A system according to claim 13, wherein said main valve (115) is a dual-valve.
15. A system according to any of the preceding claims, wherein the upper subsystem (109) comprises a remotely controllable fluid analyzer (143) for analyzing the composition of each individual layer.
16. A system according to any of the preceding claims, wherein the upper subsystem (109) comprises a remotely controllable flow meter (145) for measuring the flow of the layers.
17. A system according to any of the preceding claims, wherein the upper subsystem (109) comprises a remotely controllable back-up pressure gauge.

18. A system according to any of the preceding claims, wherein the upper subsystem (109) comprises a remotely controllable sampler carrier.
19. A system according to any of the preceding claims, wherein the control station (151) is a wireless control station.
20. A system according to claim 19, wherein the communication means between the control station (151) and the surface comprise one or more repeaters (155) to relay the communication.
21. A system according to any of the preceding claims, wherein the communication system enables to convey the test data collected by the testing means of the individual apparatuses to the surface.
22. A system according to any of the preceding claims, wherein the communication system comprises communication means between the individual apparatuses (116).
23. A system according to any of the preceding claims, wherein the communication means between the station (151) and the individual apparatuses (116) comprise a short hop link (149).
24. A system according to claim 23, wherein the short hop link (149) is an acoustic link.
25. A system according to claim 23, wherein the short hop link (149) is an electromagnetic link.
26. A system according to any of the preceding claims, wherein the communication means between the station (151) and the surface comprise a long hop link (147).
27. A system according to claim 26, wherein the long hop link (147) is an acoustic link.
28. A system according to claim 26, wherein the long hop link (147) is an electromagnetic link.

29. A multizone testing method for the testing of a plurality of subterranean layers intersected by a well, using a multizone testing system of claim 1, comprising the steps of
- (a) running and positioning said system into the well such that each individual apparatus is adjacent to a layer to be tested;
  - (b) controlling the remotely activated tools of the individual apparatuses for a sequential test of the layers.
30. A method according to claim 29, wherein the remotely activated tools of each of the individual apparatuses comprising a packer, a tester valve, a perforating gun system and testing means, step (b) comprises the following steps
- (b1) setting the packers;
  - (b2) keeping all the valves open;
  - (b3) perforating the first layer of interest using the perforating gun system of the first individual tool adjacent to said first layer;
  - (b4) testing the flow of the first layer;
  - (b5) closing the tester valve of the first individual tool;
  - (b6) keeping all the tester valves open except the ones of the layers already tested and repeating steps (b3) to (b6) for the testing of each layer.
31. A method according to claim 30, wherein the testing means comprising a pressure gauge, step (b) further comprises, after the closing of the tester valve of the first individual tool
- (b4') testing the first layer's build up using said pressure gauge.
32. A method according to claims 30 or 31, wherein the testing means comprising a pressure gauge, step (b4) comprises measuring the pressure of the flow using said pressure gauge.
33. A method according to claims 30 to 32, wherein the testing means comprising a sample carrier, step (b4) comprises collecting samples of the corresponding tested layer material using said sample carrier.
34. A method according to claims 30 to 33, wherein the upper subsystem comprising a fluid analyzer, step (b4) comprises analyzing the corresponding tested layer material with said fluid analyzer.

35. A method according to claims 30 to 34, wherein the upper subsystem comprising a flow meter, step (b4) comprises measuring the flow of the corresponding tested layer material with said flow meter.
36. A method according to claims 29 to 35, further comprising the step of  
(c) controlling the remotely activated tools of the individual apparatuses for an interference test between the currently tested layer and one or a plurality of the already tested layers.
37. A method according to claims 29 to 36, further comprising the step of  
(d) controlling the remotely activated tools of the individual apparatuses for a commingled test of at least two tested adjacent layers.
38. A method according to claim 37, wherein step (d) comprises the steps of  
(d1) reopening the tester valves of at least two already tested adjacent layers;  
(d2) testing the commingled flow.
39. A method according to claims 29 to 38, further comprising the step of  
(d') controlling the remotely activated tools of the individual apparatuses for a commingled test of all the tested layers.
40. A method according to claim 39, wherein step (d') comprises the steps of  
(d'1) reopening all the tester valves;  
(d'2) testing the commingled flow.
41. A method according to claim 40, wherein the upper subsystem comprising a main dual-valve, step (d') further comprises the steps of  
(d'3) closing the main dual-valve;  
(d'4) testing the commingled build-up.
42. A method according to claims 29 to 41, further comprising the step of  
(e) conveying the data collected by each testing means of the individual apparatuses to the surface.

43. A method according to claim 42, wherein conveying the data is made in real time.

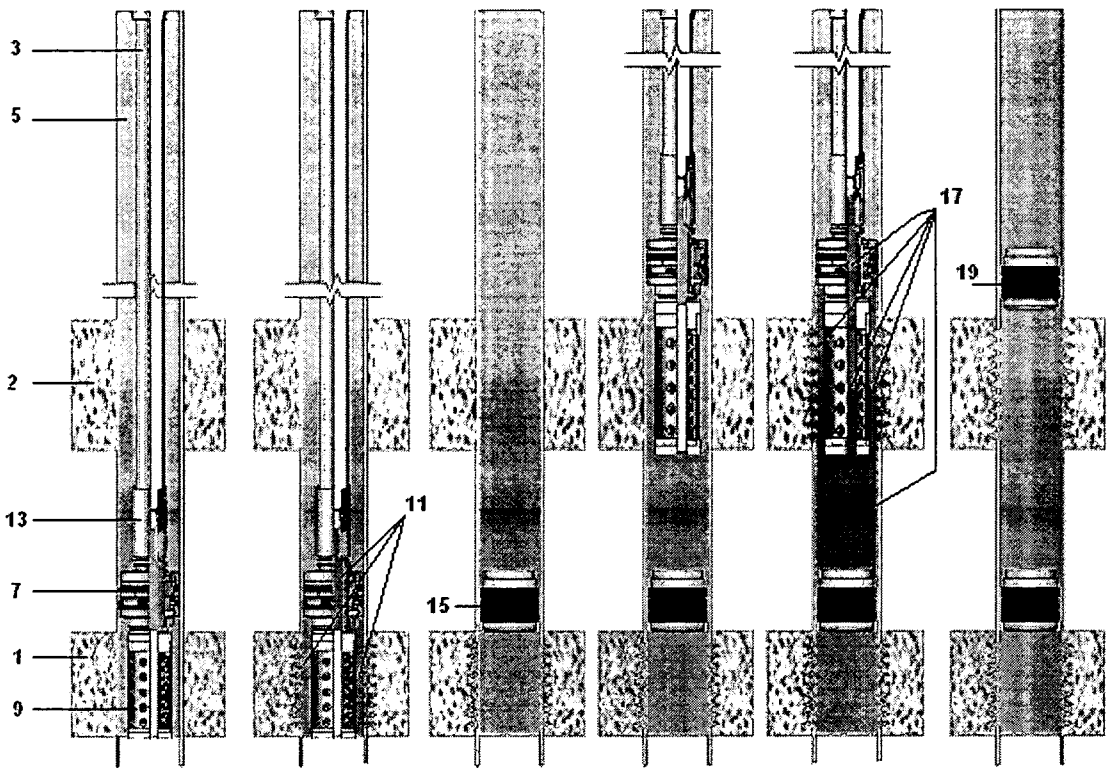

Figure 1a

Figure 1b

Figure 1c

Figure 1d

Figure 1e

Figure 1f



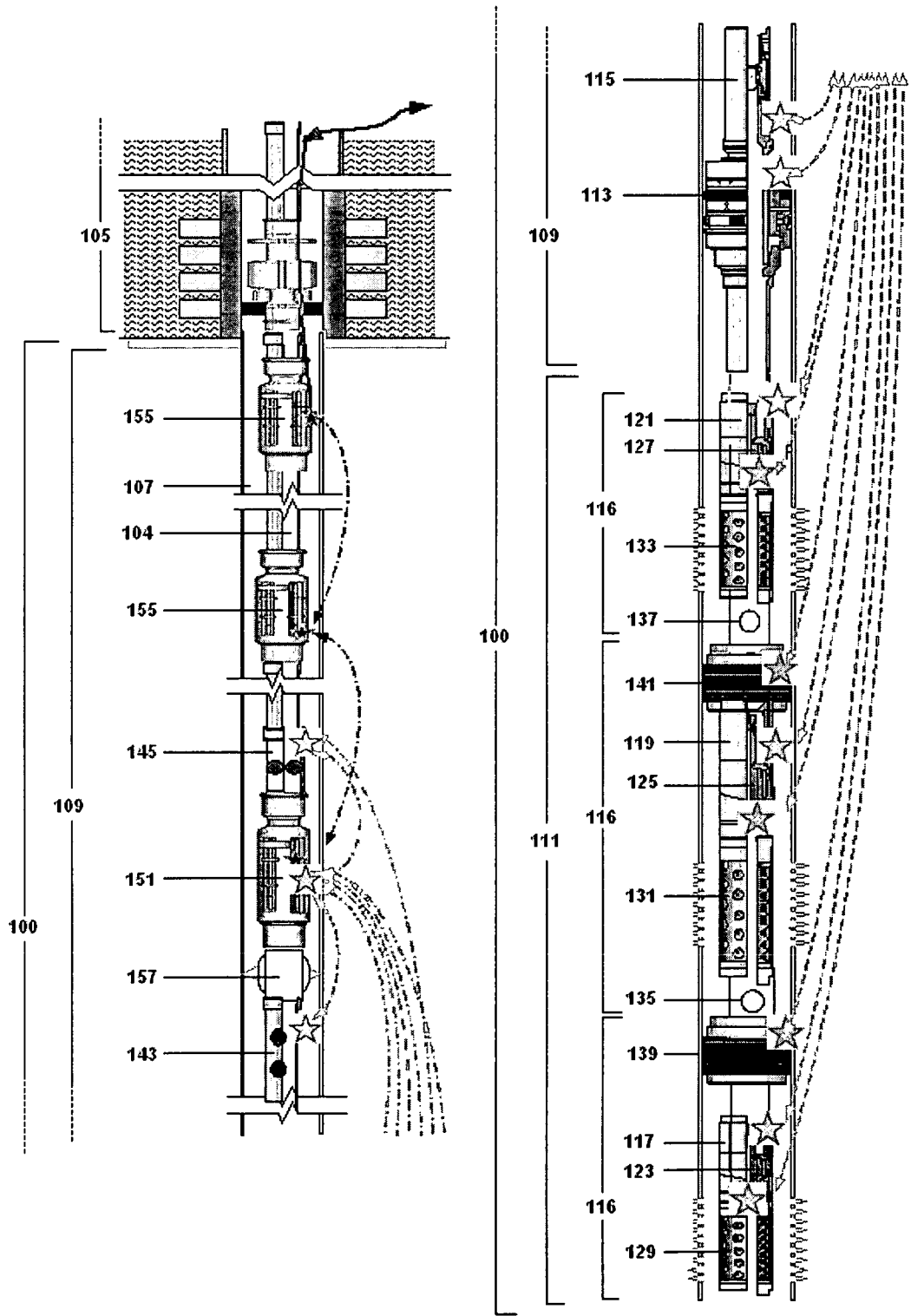

Figure 2

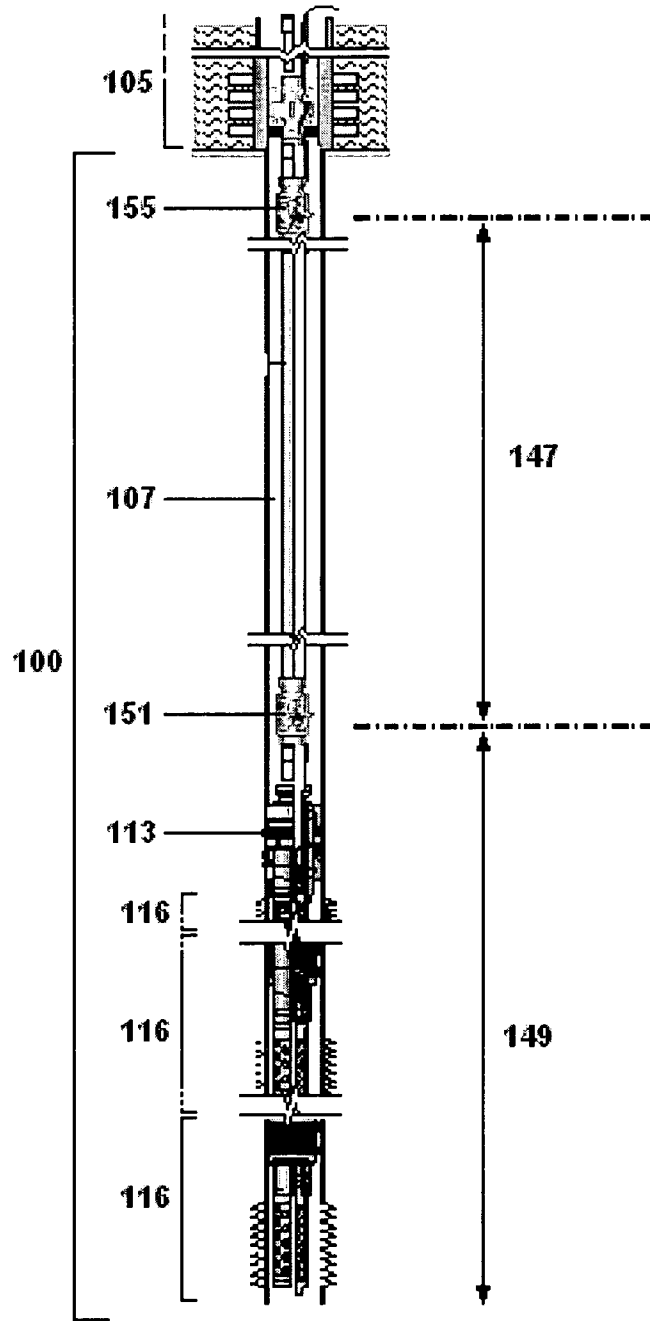

Figure 3

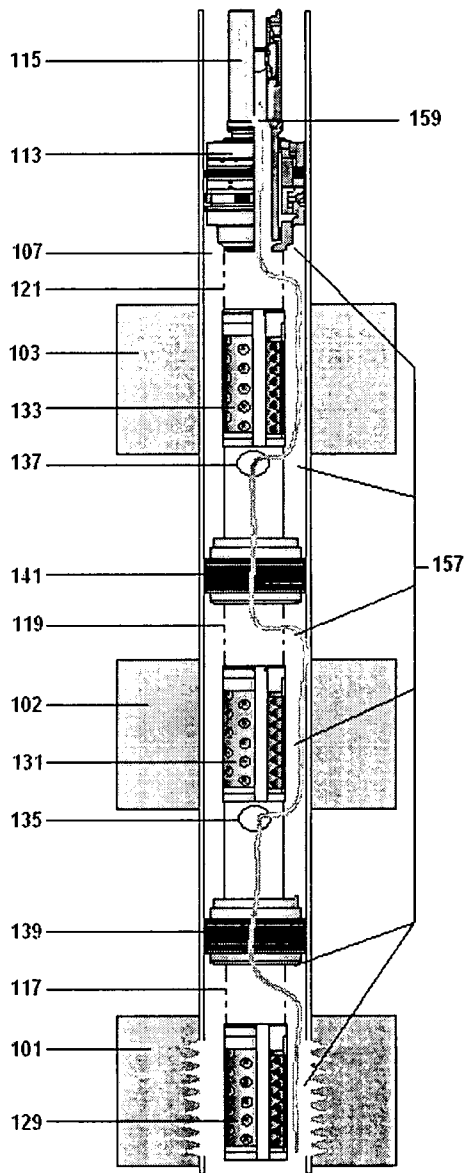

Figure 4a

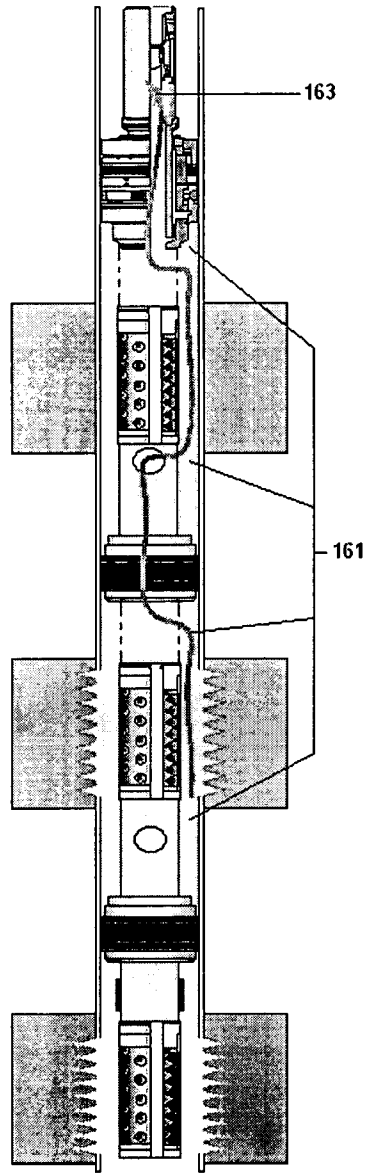

Figure 4b

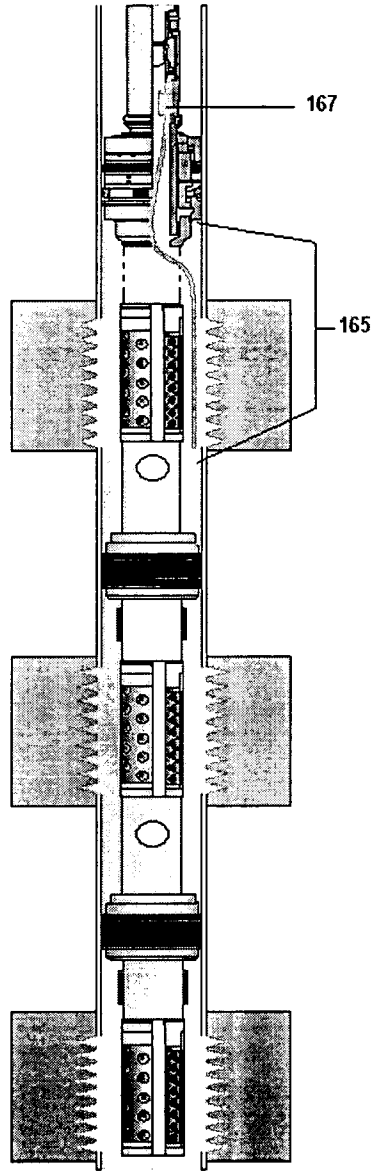

Figure 4c

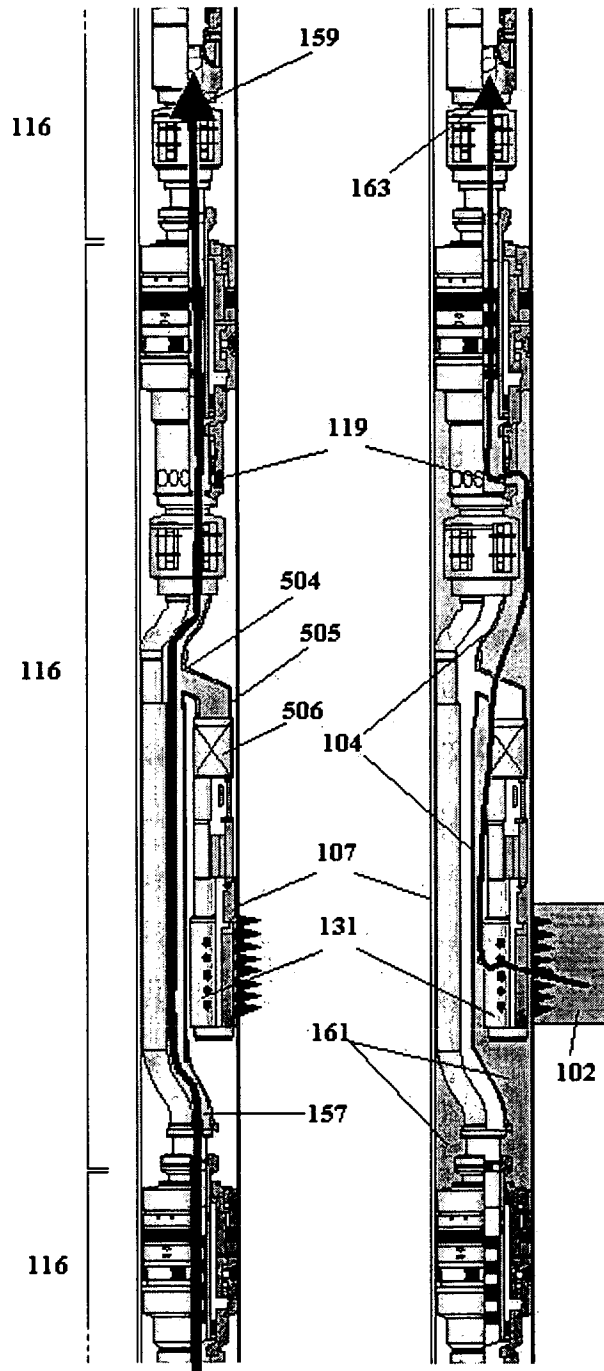

Figure 5a

Figure 5b

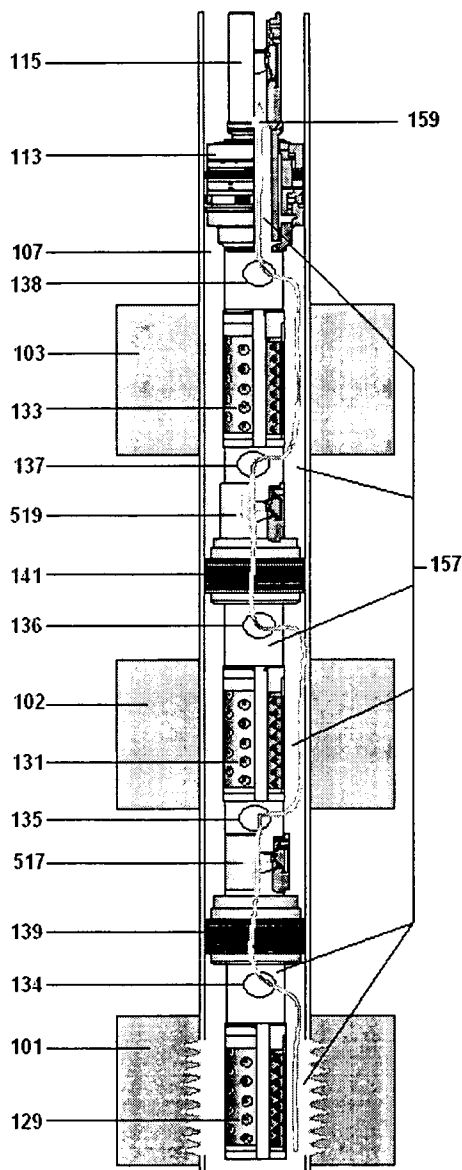

Figure 6a

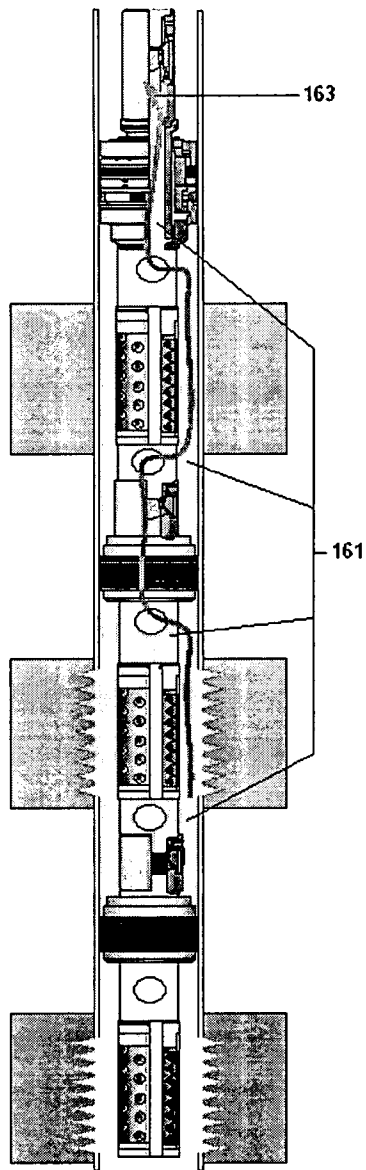

Figure 6b

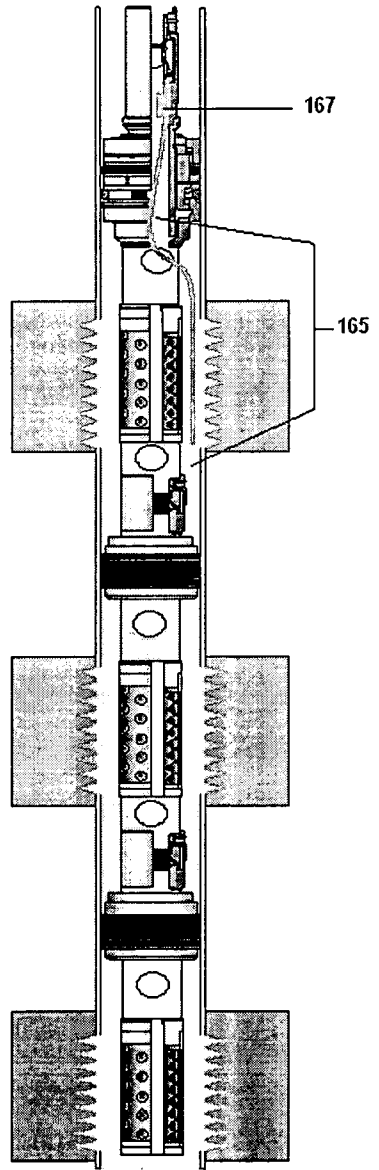

Figure 6c

		Flow	Buid-up	Flow	Buid-up	Flow	Buid-up	Flow	Buid-up
V a l i v e s	115	OPEN	OPEN	OPEN	OPEN	OPEN	OPEN	OPEN	CLOSED
	121	OPEN	OPEN	OPEN	OPEN	OPEN	CLOSED	OPEN	OPEN
	119	OPEN	OPEN	OPEN	CLOSED	CLOSED	CLOSED	OPEN	OPEN
	117	OPEN	CLOSED	CLOSED	CLOSED	CLOSED	CLOSED	OPEN	OPEN
P r e s s u r e	127	L1FI	/	L2FI	/	L3FI	L2Bup	CFI	CBup
	125		/		L2Bup	L2Bup			
	123		L1Bup	L1Bup	L1Bup	L1Bup			

Figure 7a

Figure 7b

Figure 7c

Figure 7d