



Europäisches Patentamt  
European Patent Office  
Office européen des brevets



(11) **EP 0 937 852 B1**

(12) **EUROPEAN PATENT SPECIFICATION**

(45) Date of publication and mention  
of the grant of the patent:  
**20.08.2003 Bulletin 2003/34**

(51) Int Cl.7: **E05F 11/00**, E05F 15/12,  
E05F 11/02

(21) Application number: **99102003.3**

(22) Date of filing: **01.02.1999**

(54) **Operating device for door or window units with hinged wing panels**

Betätigungsvorrichtung für Tür- oder Fensterkonstruktionen mit schwenkbaren Flügelementen  
Dispositif pour actionner les unités des portes ou des fenêtres avec des éléments des battants pivotants

(84) Designated Contracting States:  
**AT BE CH DE DK ES FI FR GB GR IE IT LI LU NL  
PT SE**

(73) Proprietor: **Pol, Germano**  
**31020 Villorba (IT)**

(30) Priority: **20.02.1998 IT VE980009**

(72) Inventor: **Pol, Germano**  
**31020 Villorba (IT)**

(43) Date of publication of application:  
**25.08.1999 Bulletin 1999/34**

(56) References cited:  
**DE-A- 1 708 455** **GB-A- 2 183 723**

**EP 0 937 852 B1**

Note: Within nine months from the publication of the mention of the grant of the European patent, any person may give notice to the European Patent Office of opposition to the European patent granted. Notice of opposition shall be filed in a written reasoned statement. It shall not be deemed to have been filed until the opposition fee has been paid. (Art. 99(1) European Patent Convention).

## Description

**[0001]** This invention relates to an operating device for door or window units with hinged wing panels, in particular for external window shutters.

**[0002]** External window shutters generally of wooden construction with their wing panels hinged together are known. They can be of solid type, in which case they are generally known as "black-out" shutters as their purpose is to completely obscure the internal room, or they can be of the type comprising a plurality of often adjustable parallel slats, in which case they are generally known as "louvre shutters". In either case they can be either of single wing panel type, ie when there is only one wing panel hinged to one or to each side-post of an opening provided in a building, or of multiple wing panel type, ie when two or more wing panels exist, one of which is hinged to the side-post and the others hinged together.

**[0003]** In every case these shutters are positioned on the outside of the window, which generally opens inwards of the building, whereas the shutters are opened outwards.

**[0004]** Consequently a drawback of known external shutters is that for their opening and closure the window has necessarily to be previously opened, which can be uncomfortable especially in winter and/or when raining.

**[0005]** A further drawback is that their opening and closure involves a manual operation, which can be tiring and uncomfortable, especially in the case of large heavy wing panels.

**[0006]** A further drawback is that whereas their closed configuration can be considered stable by virtue of the fastening means provided on the shutter, their open configuration is unstable as the fastening means are not active. It follows that the individual single or multiple wing panels have to be stabilized when in their open position, this being done by using suitable retainers, generally provided on the outer wall of the building and operable manually by the user.

**[0007]** GB-A-2183723 describes a windows or door operating mechanism having a plate adapted to be attached to a windows (door) frame and a bar to be attached to the windows (door) light, the plate and the bar being interconnected by two or more links.

**[0008]** An object of the invention is to provide a device which enables external shutters of hinged wing panel type to be operated from the inside of the room without having to open the window.

**[0009]** A further object of the invention is to provide a device which can be operated from the inside of the room either manually or mechanically by means of a suitable actuator.

**[0010]** A further object of the invention is to provide a device which enables the shutter to be locked in the open configuration without the need for the user to lean outwards.

**[0011]** A further object of the invention is to provide a

device which using a small number of modular components can be adapted to shutters of different types both in relation to the number of wing panels and in relation to their method of opening.

5 **[0012]** A further object of the invention is to provide a device which can also be applied to different types of hinged wing panel door or window units, and in particular to gates of multiple wing panel type.

10 **[0013]** All these aims and further ones which will result from the following description are attained according to the invention through an operating device for door or window units with hinged wing panels as described in the independent claims.

15 **[0014]** Some preferred embodiments of the invention are described in detail hereinafter with reference to the accompanying drawings, on which:

Figure 1 is a schematic partial front view of a first embodiment of the device of the invention, for manually operating a single wing panel shutter;

20 Figure 2 is a perspective view thereof in the uninstalled state without the wing panel;

Figure 3 is a horizontal section therethrough on the line III-III of Figure 1;

25 Figure 4 shows part of it in the same view as Figure 3, but on a larger scale;

Figure 5 shows it in the same view as Figure 4 but in the motorized version;

30 Figure 6 shows a second embodiment of the device of the invention in the same view as Figure 1, for manually operating a shutter with two wing panels accordion-foldable on the outside of the building;

35 Figure 7 shows it in the same view as Figure 2;

Figure 8 is a horizontal section therethrough on the line VIII-VIII of Figure 6;

Figure 9 shows part of it in the same view as Figure 8, but on a larger scale;

40 Figure 10 shows a third embodiment of the device of the invention in the same view as Figure 1, for manually operating a shutter with two wing panels foldable one on the other through 180° within the thickness of the building wall;

45 Figure 11 shows it in the same view as Figure 2;

Figure 12 is a horizontal section therethrough on the line XII-XII of Figure 10;

50 Figure 13 shows part of it in the same view as Figure 12, but on a larger scale;

Figure 14 shows in the same view as Figure 1 the device of the invention for manually operating a shutter with two wing panels foldable through 90° one to other on the outside of the building;

55 Figure 15 shows it in same view as Figure 2;

Figure 16 is a horizontal section therethrough on the line XVI-XVI of Figure 14;

- Figure 17 shows part of it in the same view as Figure 16, but on a larger scale;
- Figure 18 shows it in the same view of Figure 5 in a motorized version;
- Figure 19 shows it in the same view as Figure 18 driven by a crank; and
- Figure 20 shows it driven by a hydraulic jack.

**[0015]** As can be seen from the drawings, the device of the invention in the embodiment shown in Figures 1-4 is applied to a black-out shutter with a single wing panel which is hinged to a fixed support frame 4 preferably formed from metal tubular section pieces incorporated into or otherwise fixed to the wall 6. For simplicity of drawing only one half of the shutter is shown, whereas in reality the expression "shutter with one wing panel" means a shutter with a wing panel hinged to each of the two uprights of the support frame 4, ie a shutter comprising a total of two wing panels.

**[0016]** In addition the drawings show a shutter 2 with an internally incorporated movable frame 8 forming the support member effectively hinged to the fixed frame 4. The fixed frame 4 and movable frame 8 are hinged together by a controlled hinge forming the characterising element of this invention and indicated overall by the reference numeral 10, and an idle hinge 12 which could be of traditional type and be provided in that number and arrangement required by the dimensions of the wing panel and the stresses consequently imposed by the system.

**[0017]** The hinge 10 is in reality formed by two box elements 14 and 16, the first of which is welded to the fixed support frame 4 and the second to the movable frame 8.

**[0018]** A block 20 is hinged to the fixed box element 14 on a pin 18, and is rigid with a lever 22 for manually operating the shutter 2.

**[0019]** In the illustrated example the lever 22 is simply inserted into a cavity provided in the block 20, but instead could be screwed to the block 20 and be constructed in two jointed parts to enable it to be securely fixed to said block while at the same time enabling it to lie parallel to the wall 6 when not in use, in order not to form an obstruction.

**[0020]** One end of a bar 24 is hinged to the block 20, its other end being hinged to a first rocker arm 26. This, in proximity to the end 28 at which it is hinged to the bar 24, is provided with pin 30 guided with its two ends in a pair of slots 32 provided in two opposing walls of the box element 14 parallel to the closure plane of the shutter 2, ie to the plane in which the shutter lies when in its closed configuration.

**[0021]** The other end of the rocker arm 26 is hinged to the box element 16.

**[0022]** In addition to the first rocker arm 26 there is also a second rocker arm 34, which connects together the two box elements 14 and 16 of the hinge 12. This second rocker arm 34 is hinged at one end to the box

element 14 and is provided with a pin 36 slidable with its two ends along two slots 38 provided in two opposing walls of the box element 16, parallel to the slot 32.

**[0023]** The two rocker arms 26 and 34 are also hinged together in their central region by a pin 40.

**[0024]** The device of the invention operates in the following manner:

when the shutter is in its closed configuration the block 20 lies such that the lever 22 rigid with it projects perpendicularly from the inside of the wall 6, after passing through a recess 42 provided in it. In this configuration the movable frame 8 lies parallel to the wall 6, within the compartment provided in it for the window unit, and maintains the shutter 2 in its closed state. If while in this state the user operates the lever 22 in the sense of rotating it about the pin 18 by which it is hinged to the box element 14, in the direction of the arrow 44 in Figure 3, the rotation of the block 20 causes the bar 24 to move in the direction of the arrow 46 in Figure 4, so urging in the same direction that end of the rocker arm 26 to which said bar is hinged.

**[0025]** In its turn the rocker arm 26, which is compelled to slide with its pin 30 along the slot 32, while at the same time being hinged at its other end to the box element 16, is subjected to a roto-traslational movement which causes the second rocker arm 34 to undergo a similar movement by virtue of the hinge 4 between the two.

**[0026]** The movement of the two rocker arms 26 and 34, in combination with the constraints to which they are subjected, causes the box element 16 to undergo a roto-translational movement outwards which, if the various lever arms and the position and length of the slot 32 and 38 are correctly chosen, results in completion of the movement of the shutter 2 into the totally open configuration, in which it has rotated through 180° from its closed configuration and adheres to the outside of the wall 6.

**[0027]** Operating the lever 22 in the opposite direction causes the various parts to move in the opposite sequence to return the shutter 2 into its closed condition, in which a traditional mechanical or electromechanical locking device or the like can be provided to stabilize this condition against any opening attempts made directly against the shutter 2.

**[0028]** In the embodiment shown in Figure 5, which employs the same operating principle and the same type of single wing panel shutter, operating is motorized instead of manual. In this embodiment, in which corresponding parts have the same reference numerals, the bar 24, instead of being connected to the manual operating lever 22, is connected to a threaded rod 48 engaged in an axially threaded bush on a rigid gear 50, coupled via a worm to an electric motor 52. It will be apparent that rotating the motor 52 in one or other direction causes the ring gear to rotate correspondingly, with consequent axial movement of the threaded rod 48 operating the bar 24.

**[0029]** The embodiment shown in Figure 6-9 is provided to operate a different type of shutter comprising two wing panels which when in the closed configuration lie in the shutter closure plane and when in the open configuration are folded 180° apart in the opposite direction onto the outside of the building.

**[0030]** More specifically, the shutter to which this second embodiment of the operating device is applied, comprises a first wing panel 54 hinged to the wall and a second wing panel 2 hinged to the first. Consequently the movable frame consists in reality of two frames, namely a frame 8 incorporated in the wing panel 2 and a frame 56 incorporated in the wing panel 54.

**[0031]** Compared with the preceding embodiment, of which it uses the same reference numerals for corresponding parts, in this embodiment the controlled hinge 12 is in reality formed not only from the two box elements 14 and 16 of the preceding embodiment, but also from an intermediate third box element 58 of length equal to the width of the intermediate frame 56 and welded to it.

**[0032]** Both the hinged connections between the box element 14 and intermediate element 58 and between said intermediate element 58 and the box element 16 are made by a pair of intermediate rocker arms 60,60' in the manner already described for the preceding embodiment.

**[0033]** The two intermediate rocker arms 60,60' are also connected together by a pair of bars 62,62' hinged to a further rocker arm 64, which is hinged centrally on a pin 66 fixed to the intermediate box element 58.

**[0034]** This second embodiment of the device of the invention operates in the following manner:

the roto-translational movement of the rocker arm 26 causes the rocker arm 60 hinged to it to undergo roto-translational movement so, by virtue of the coupling between the two rocker arms 60,60', causing this latter to undergo roto-translational movement to roto-translational move the rocker arm 34. The position and dimensions of the various hinge pins are chosen such that on termination of the angular movement of the lever 22 the box element 58 and hence the intermediate wing panel 54 rigid therewith has undergone an outward roto-translational movement through 180°, to lie parallel with and against the wall 6, the box element 16 having undergone a roto-translational movement through 180° in the opposite direction to the intermediate box element 58, so that the shutter 2 lies parallel to and external to the intermediate wing panel 54 (see dashed lines in Figures 8 and 9). This embodiment, as in the case of the preceding, can also be motorized by replacing the lever 22 for manually operating the bar 24 with a threaded lever operated axially by an electric motor, in the manner as that described with reference to Figure 5.

**[0035]** The embodiment shown in Figures 10-13 is again provided for operating shutters with two wing panels which however, instead of being each rotated through 180° in opposite directions in passing from the open configuration to the closed configuration and vice

versa to lie one on the other parallel to the outside of the building, are in this case rotated one through 90° in one direction and the other through 180° in the opposite direction so as to be able to lie one on the other within the thickness of the wall in the compartment containing the window unit.

**[0036]** The constructional and operational characteristics of this embodiment of the device are substantially similar to the preceding, the only difference being a different ratio between the two arm portions of the rocker arm 64 and different parts for hinging the bars 62,62' to the respective intermediate rocker arms 60,60', such that the same roto-translational movement of the rocker arm 26 caused by the lever 22 or alternatively by the electric motor produces a different roto-translational movement of the rocker arm 60, which in this case undergoes a rotation of 90° instead of 180°. By virtue of the different lengths of the two arm portions of the rocker arm 64, this movement causes the box element 16 to undergo a roto-translational movement relative to the intermediate box element 58 in which the rotation part of the movement is through 180°.

**[0037]** The embodiment shown in Figures 14-17 is provided for operating a different type of shutter comprising two wing panels, of which when in the open configuration the first is rotated through 90° from the shutter closure plane and the second is rotated through 90° from the first.

**[0038]** This difference in angular travel is due essentially to a different choice of length of the arm portions of the rocker arm 64 and of points of hinging of the bars 62,62' with respect to the rocker arms 60,60'.

**[0039]** In the embodiment shown in Figure 18, which employ the same operating principle and the same type of single wing panel it is foreseen that the bar 24 is connected to a block 66 integral with a tube 68 internally threaded for the engagement from a worm 70 rotatably connected to a bevel gear system 72 driven by an electric motor 74 or a crank 76 (see Figure 19). It is obvious that the rotation of the bevel gear system in one or other direction causes the displacement of the block 66 with the consequent displacement of the bar 24.

**[0040]** In the embodiment shown in Figure 20 the bar 24 is connected to the stem 78 of a hydraulic jack.

**[0041]** From the foregoing it is apparent that the device of the invention is particularly advantageous, and in particular:

- it enables external shutter with hinged wing panels to be operated from the inside of the room, without having to open the window,
- it enables shutters to be operated either manually or by motorized operation,
- it enables the shutter to be locked in the closed configuration without having to use external locking members,
- it can be constructed with modular components, of which only certain internal components have to be

varied for its application to shutters of different types,

- it can be used to operate hinged wing panels of door or window units other than external shutters, and in particular of gates,
- it allows to make reinforced shutters by inserting transverse rods inside the frame.

## Claims

1. An operating device for door or window units with hinged wing panels, in particular for external window shutters, **characterised by** comprising:

- a support structure (4) fixed to the wall (6) and having hinged thereto on a vertical axis at least one wing panel (2) to be operationally moved between a closed position and an open position,
- at least one box element (16) incorporated in said wing panel (2),
- a first rocker arm (26) having a first end constrained to move along a predetermined path (32) relative to said support structure (4) and its second end hinged to said box element (16),
- a second rocker arm (34) having a first end constrained to move along a predetermined path (38) relative to said box element (16), its second end hinged to said support structure (4), and its central portion hinged to the central portion of said first rocker arm (26),
- operating means (22,24,48,52) associated with said first rocker arm (26) and acting in the sense of causing its said first end to move along said predetermined path (32) relative to said support structure (4).

2. A device as claimed in claim 1, **characterised in that** said support structure (4) consists of a peripheral frame.

3. A device as claimed in claim 1, **characterised in that** the wing panel (2) is hinged to the support structure (4) by a plurality of hinges (10,12), of which at least one (10) is of controlled type.

4. A device as claimed in claim 3, **characterised by** comprising a movable frame (8) incorporated into the wing panel (2) and hinged to the support structure (4) by the hinges (10,12).

5. A device as claimed in claim 3, **characterised in that** the controlled hinge (10) consists of two box elements (14,16), the first (14) of which is fixed to the support structure (4) and the second of which is incorporated into the wing panel (2).

6. A device as claimed in claim 5, **characterised in that** the first end of the first rocker arm (26) is constrained to slide via a pin (30) thereof within rectilinear guides (32) provided in two opposing walls of the box element (14).

7. A device as claimed in claim 5, **characterised in that** the first end of the second rocker arm (34) is constrained to slide via a pin (36) thereof within rectilinear guides (28) provided in two opposing walls of the box element (14).

8. A device as claimed in claim 1, **characterised by** comprising an operating lever (22) hinged to the support structure (4) and connected to the first end of the first rocker arm (26).

9. A device as claimed in claim 8, **characterised in that** the operating lever (22) is of foldable type.

10. A device as claimed in claim 1, **characterised by** comprising a bar (24,48) hinged to the first end of the first rocker arm (26) and associated with an actuator (52) for moving said first end along said path (32).

11. A device as claimed in claim 1, **characterised by** comprising an electric motor (52) for operating a worm-helical gear reducer provided with a threaded axial cavity engaged by a threaded rod (48) connected to the first rocker arm (26).

12. A device as claimed in claim 1 **characterised in that** the first rocker arm (26) is connected to a block (66) integral with a tube (68) internally threaded for the engagement from a worm (70) rotatably connected to a bevel gear system (72) driven by an electric motor (74).

13. A device as claimed in claim 1 **characterised in that** the first rocker arm (26) is connected to a block (66) integral with a tube (68) internally threaded for the engagement from a worm (70) rotatably connected to a bevel gear system (72) driven by a crank (76).

14. A device as claimed in claim 1 **characterised in that** the first rocker arm (26) is connected to the stem (78) of a hydraulic jack (80).

15. A device for operating a door or window unit with two hinged-together wing panels (2,54), **characterised by** comprising:

- at least one controlled hinge (10) comprising three box elements (14,16,58), of which the first (14) is rigid with a support structure (4), the second (16) is incorporated into the outer wing pan-

- el (2) and the third (58), of length equal to the width of the intermediate wing panel (54), is incorporated into this latter,
- a first rocker arm (26) having a first end constrained to move along a predetermined path (32) relative to the first box element (14) and its second end hinged to the third box element (58),
  - a third rocker arm (60) having a first end constrained to move along a predetermined path relative to the third box element (58), its second end hinged to said first box element (14), and its central part hinged to the central part of said first rocker arm (26),
  - a fourth rocker arm (60') having a first end constrained to move along a predetermined path relative to said third box element (58), and its second end hinged to said second box element (16),
  - a second rocker arm (34) having a first end constrained to move along a predetermined path (38) relative to said second box element (16), its second end hinged to said third box element (58), and its central part hinged to the central part of said fourth rocker arm (60'),
  - a fifth rocker arm (64) housed in said second box element (54) and having its arm portions connected via bars (62,62') to the first end of said third and fourth rocker arm (60,60'),
  - operating means (22,20,24,48,52) associated with said first rocker arm (26) and acting in the sense of causing its said first end to move along said predetermined path (32) relative to said first box element (14).

### Patentansprüche

#### 1. Betätigungsvorrichtung für Tür- und Fenster-Einheiten mit angelenkten Flügeltafeln, insbesondere für äußere Fensterläden, **dadurch gekennzeichnet, dass** sie umfasst:

- eine Tragstruktur (4), die an der Wand (6) befestigt und an der an einer vertikalen Achse wenigstens eine Flügeltafel (2) angelenkt ist, die zwischen einer geschlossenen Position und einer geöffneten Position bewegbar ist,
- wenigstens ein Gehäuseelement (16), das in der besagten Flügeltafel (2) vorgesehen ist,
- einen ersten einarmigen Hebel (26) mit einem ersten Ende, das entlang einem vorgegebenen Weg (32) relativ zu der besagten Tragstruktur (4) zwangsgeführt ist und dessen zweites Ende an dem besagten Gehäuseelement (16) angelenkt ist,
- einem zweiten einarmigen Hebel (34) mit einem ersten Ende, das entlang einem vorgege-

- benen Weg (38) relativ zu dem besagten Gehäuseelement (16) zwangsgeführt ist, und dessen zweites Ende an der besagten Tragstruktur (4) angelenkt ist, und dessen mittlerer Abschnitt an dem mittleren Abschnitt des besagten ersten einarmigen Hebels (26) angelenkt ist,
- einem Betätigungsmittel (22, 24, 48, 52), die das besagten einarmigen Hebel (26) zugeordnet und in dem Sinn wirksam ist, dass es dazu führt, dass das besagte erste Ende entlang dem besagten vorgegebenen Weg (32) relativ zu der besagten Tragstruktur (4) bewegt wird.

2. Vorrichtung nach Anspruch 1, **dadurch gekennzeichnet, dass** die besagte Tragstruktur (4) aus einem äußeren Rahmen besteht.

3. Vorrichtung nach Anspruch 1, **dadurch gekennzeichnet, dass** die Flügeltafel (2) an der Tragstruktur (4) mit einer Vielzahl von Gelenken (10, 12) angelenkt ist, von denen wenigstens eines (10) vom kontrollierten Typ ist.

4. Vorrichtung nach Anspruch 3, **dadurch gekennzeichnet, dass** sie einen bewegbaren Rahmen (8) umfasst, der in die Flügeltafel (2) eingebaut und an der Tragstruktur (4) mit Gelenken (10, 12) angelenkt ist.

5. Vorrichtung nach Anspruch 3, **dadurch gekennzeichnet, dass** das kontrollierte Gelenk (10) aus zwei Gehäuseelementen (14, 16) besteht, wobei das erste (14) an der Tragstruktur (4) befestigt und das zweite in die Flügeltafel (2) eingebaut ist.

6. Vorrichtung nach Anspruch 5, **dadurch gekennzeichnet, dass** das erste Ende des ersten einarmigen Hebels (26) zwangsweise über einen Stift (30) daran in rechteckigen Führungen (32) verschiebbar ist, die an zwei gegenüberliegenden Wänden des Gehäuseelements (14) vorgesehen sind.

7. Vorrichtung nach Anspruch 5, **dadurch gekennzeichnet, dass** das erste Ende des zweiten einarmigen Hebels (34) zwangsweise über einen Stift (36) daran in rechtwinkligen Führungen (28) verschiebbar ist, welche in zwei gegenüberliegenden Wänden des Gehäuseelements (14) vorgesehen sind.

8. Vorrichtung nach Anspruch 1, **dadurch gekennzeichnet, dass** sie einen Betätigungshebel (22) umfasst, der an der Tragstruktur (4) angelenkt und mit dem ersten Ende des ersten einarmigen Hebels (26) verbunden ist.

9. Vorrichtung nach Anspruch 8, **dadurch gekenn-**

**zeichnet, dass** der Betätigungshebel (22) vom faltbaren Typ ist.

10. Vorrichtung nach Anspruch 1, **dadurch gekennzeichnet, dass** sie eine Stange (24, 48) umfasst, die an das erste Ende des ersten einarmigen Hebels (26) angelenkt und einem Aktuator (52) zugeordnet ist, um das besagte erste Ende entlang dem besagten Weg (32) zu bewegen. 5
11. Vorrichtung nach Anspruch 1, **dadurch gekennzeichnet, dass** sie einen Elektromotor (52) zur Betätigung eines Schneckenreduziergetriebes aufweist, welches mit einer mit einem Gewinde versehenen axialen Ausnehmung versehen ist, in das eine Gewindestange (48) eingreift, die mit dem ersten einarmigen Hebel (26) verbunden ist. 10
12. Vorrichtung nach Anspruch 1, **dadurch gekennzeichnet, dass** der erste einarmige Hebel (26) mit einem Block (66) verbunden ist, der mit einem Rohr (68) eine Einheit bildet, welches im Inneren zum Eingriff durch eine Schnecke (70) mit einem Gewinde versehen ist, welche drehbar mit einem Kegelradgetriebesystem (72) verbunden ist, welches durch einen Elektromotor (74) angetrieben wird. 15
13. Vorrichtung nach Anspruch 1, **dadurch gekennzeichnet, dass** der erste einarmige Hebel (26) mit einem Block (66) verbunden ist, der mit einem Rohr (68) eine Einheit bildet, welches innen zum Eingriff einer Schnecke (70) mit einem Gewinde versehen ist, welche drehbar mit einem Kegelradgetriebesystem (72) verbunden ist, welches durch eine Kurbel (76) angetrieben wird. 20
14. Vorrichtung nach Anspruch 1, **dadurch gekennzeichnet, dass** der erste einarmige Hebel (26) mit dem Schaft (78) einer hydraulischen Hebeeinrichtung (80) verbunden ist. 25
15. Vorrichtung nach Anspruch 1 zur Betätigung einer Türoder Fenstereinheit mit zwei aneinander angelenkten Flügeltafeln (2, 54), **dadurch gekennzeichnet, dass** sie umfasst: 30
- wenigstens ein kontrolliertes Gelenk (10), das drei Gehäuseelemente (14, 16, 58) umfasst, von denen das erste (14) starr mit einer Tragsstruktur (4) verbunden ist, das zweite (16) in die äußere Flügeltafel (2) eingebaut ist und das dritte (58) mit einer Länge, die der Breite der mittleren Flügeltafel (54) entspricht, in die letztere eingebaut ist, 35
  - einem ersten einarmigen Hebel (26), der ein erstes Ende aufweist, das entlang eines vorgegebenen Weges (32) relativ zu dem ersten Gehäuseelement (14) zwangsgeführt ist, und des-

- sen zweites Ende an dem dritten Gehäuseelement (58) angelenkt ist,
- einem dritten einarmigen Hebel (60), der ein erstes Ende aufweist, das entlang einem vorgegebenen Weg relativ zu dem dritten Gehäuseelement (58) zwangsgeführt ist, dessen zweites Ende an dem besagten ersten Gehäuseelement (14) angelenkt ist und dessen mittlerer Teil an dem mittleren Teil des besagten ersten einarmigen Hebels (26) angelenkt ist,
- einem vierten einarmigen Hebel (60'), der ein erstes Ende aufweist, das entlang einem vorgegebenen Weg relativ zu dem besagten dritten Gehäuseelement (58) zwangsgeführt ist, und dessen zweites Ende an dem besagten zweiten Gehäuseelement (16) angelenkt ist,
- einen zweiten einarmigen Hebel (34), der ein erstes Ende aufweist, das entlang einem vorgegebenen Weg (38) relativ zu dem besagten zweiten Gehäuseelement (16) zwangsgeführt ist, dessen zweites Ende an dem besagten dritten Gehäuseelement (58) angelenkt ist, und dessen mittlerer Teil an dem mittleren Teil des vierten einarmigen Hebels (60') angelenkt ist,
- einem fünften einarmigen Hebel (64), der in dem zweiten Gehäuseelement (54) aufgenommen ist und Armabschnitte aufweist, die mittels Stangen (62, 62') mit dem ersten Ende des besagten dritten und vierten einarmigen Hebels (60, 60') verbunden sind,
- Betätigungsmittel (22, 20, 24, 48, 52), die dem besagten ersten einarmigen Hebels (26) zugeordnet sind und in dem Sinne wirken, dass sie dazu führen, dass das besagte erste Ende entlang dem besagten vorgegebenen Weg (32) relativ zu dem besagten ersten Gehäuseelement (14) bewegt wird. 40

#### 40 Revendications

1. Dispositif d'actionnement pour unités de porte ou de fenêtre avec des battants pivotants, en particulier pour des volets de fenêtre externe, **caractérisé en ce qu'il comprend :** 45
- une structure porteuse (4) fixée au mur (6) et, articulée par rapport à celle-ci autour d'un axe vertical, au moins un battant (2) devant se déplacer lors de l'actionnement entre une position fermée et une position ouverte, 50
  - au moins un élément de boîtier (16) incorporé dans ledit battant (2),
  - un premier bras à bascule (26) ayant une première extrémité contrainte à se déplacer le long d'un chemin prédéterminé (32) par rapport à ladite structure porteuse (4) et sa deuxième extrémité articulée audit élément de boîtier (16), 55

- un deuxième bras à bascule (34) ayant une première extrémité contrainte à se déplacer le long d'un chemin prédéterminé (38) par rapport audit élément de boîtier (16), sa deuxième extrémité articulée à ladite structure porteuse (4), et sa portion centrale articulée à la portion centrale dudit premier bras à bascule (26),
  - des moyens d'actionnement (22, 24, 48, 52) associés audit premier bras à bascule (26) et agissant de manière à faire déplacer sa dite première extrémité le long dudit chemin prédéterminé (32) par rapport à ladite structure porteuse (4).
2. Dispositif comme revendiqué dans la revendication 1, **caractérisé en ce que** ladite structure porteuse (4) consiste en un bâti de périmétral.
  3. Dispositif comme revendiqué dans la revendication 1, **caractérisé en ce que** le battant (2) est articulé à la structure porteuse (4) par une pluralité de charnières (10, 12), dont au moins une (10) est de type commandé.
  4. Dispositif comme revendiqué dans la revendication 3, **caractérisé en ce qu'il** comprend un cadre mobile (8) incorporé dans le battant (2) et articulé à la structure porteuse (4) par les charnières (10, 12).
  5. Dispositif comme revendiqué dans la revendication 3, **caractérisé en ce que** la charnière contrôlée (10) consiste en deux éléments de boîtier (14, 16), dont le premier (14) est fixé la structure porteuse (4) et dont le deuxième est incorporé dans le battant (2).
  6. Dispositif comme revendiqué dans la revendication 5, **caractérisé en ce que** la première extrémité du premier bras à bascule (26) est contrainte à glisser vers un téton (30) de celui-ci dans des guides rectilignes (32) ménagés dans deux parois opposées de l'élément de boîtier (14).
  7. Dispositif comme revendiqué dans la revendication 5, **caractérisé en ce que** la première extrémité du deuxième bras à bascule (34) est contrainte à glisser vers un téton (36) de celui-ci dans des guides rectilignes (28) ménagés dans deux parois opposées de l'élément de boîtier (14).
  8. Dispositif comme revendiqué dans la revendication 1, **caractérisé en ce qu'il** comprend un levier d'actionnement (22) articulé à la structure porteuse (4) et relié à la première extrémité du premier bras à bascule (26).
  9. Dispositif comme revendiqué dans la revendication 8, **caractérisé en ce que** le levier d'actionnement (22) est de type pliable.
  10. Dispositif comme revendiqué dans la revendication 1, **caractérisé en ce qu'il** comprend une barre (24, 48) articulée à la première extrémité du premier bras à bascule (26) et associée à un actionneur (52) pour déplacer ladite première extrémité le long dudit chemin (32).
  11. Dispositif comme revendiqué dans la revendication 1, **caractérisé en ce qu'il** comprend un moteur électrique (52) pour actionner un réducteur à vis sans fin munie d'une cavité axiale filetée engrenée avec une tige filetée (48) reliée au premier bras à bascule (26).
  12. Dispositif comme revendiqué dans la revendication 1, **caractérisé en ce que** le premier bras à bascule (26) est relié à un bloc (66) en une seule pièce avec un tube (68) fileté intérieurement pour s'engrener avec une vis sans fin (70) reliée à rotation à un système d'engrenage conique (72) mené par un moteur électrique (74).
  13. Dispositif comme revendiqué dans la revendication 1, **caractérisé en ce que** le premier bras à bascule (26) est relié à un bloc (66) en une seule pièce avec un tube (68) fileté intérieurement pour s'engrener avec une vis sans fin (70) reliée à rotation à un système d'engrenage conique (72) mené par une manivelle (76).
  14. Dispositif comme revendiqué dans la revendication 1, **caractérisé en ce que** le premier bras à bascule (26) est relié à une tige (78) d'un vérin hydraulique (80).
  15. Dispositif pour actionner une unité de porte ou de fenêtre avec deux battants pivotants ensemble (2, 54), **caractérisé en ce qu'il** comprend :
    - au moins une charnière commandée (10) comprenant trois éléments de boîtier (14, 16, 58), dont le premier (14) est rigide avec une structure porteuse (4), le deuxième (16) est incorporé dans le battant extérieur (2) et le troisième (58), de longueur égale à la largeur du battant intermédiaire (54), est incorporé dans ce dernier,
    - un premier bras à bascule (26) ayant une première extrémité contrainte à se déplacer le long d'un chemin prédéterminé (32) par rapport au premier élément de boîtier (14) et sa deuxième extrémité articulée au troisième élément de boîtier (58),
    - un troisième bras à bascule (60) ayant une première extrémité contrainte à se déplacer le long d'un chemin prédéterminé par rapport au troi-

- sième élément de boîtier (58), sa deuxième extrémité articulée audit premier élément de boîtier (14), et sa partie centrale articulée à la partie centrale dudit premier bras à bascule (26),
- un quatrième bras à bascule (60') ayant une première extrémité contrainte à se déplacer le long d'un chemin prédéterminé par rapport audit troisième élément de boîtier (58), et sa deuxième extrémité articulée audit deuxième élément de boîtier (16),
  - un deuxième bras à bascule (34) ayant une première extrémité contrainte à se déplacer le long d'un chemin prédéterminé (38) par rapport audit deuxième élément de boîtier (16), sa deuxième extrémité articulée audit troisième élément de boîtier (58), et sa partie centrale articulée à la partie centrale dudit quatrième bras à bascule (60'),
  - un cinquième bras à bascule (64) logé dans ledit deuxième élément de boîtier (54) et ayant ses parties de bras reliées via des barres (62, 62') à la première extrémité desdits troisième et quatrième bras à bascule (60, 60'),
  - des moyens d'actionnement (22, 20, 24, 48, 52) associés audit premier bras à bascule (26) et agissant de manière à faire déplacer sa dite première extrémité le long dudit chemin prédéterminé (32) par rapport audit premier élément de boîtier (14).

5

10

15

20

25

30

35

40

45

50

55

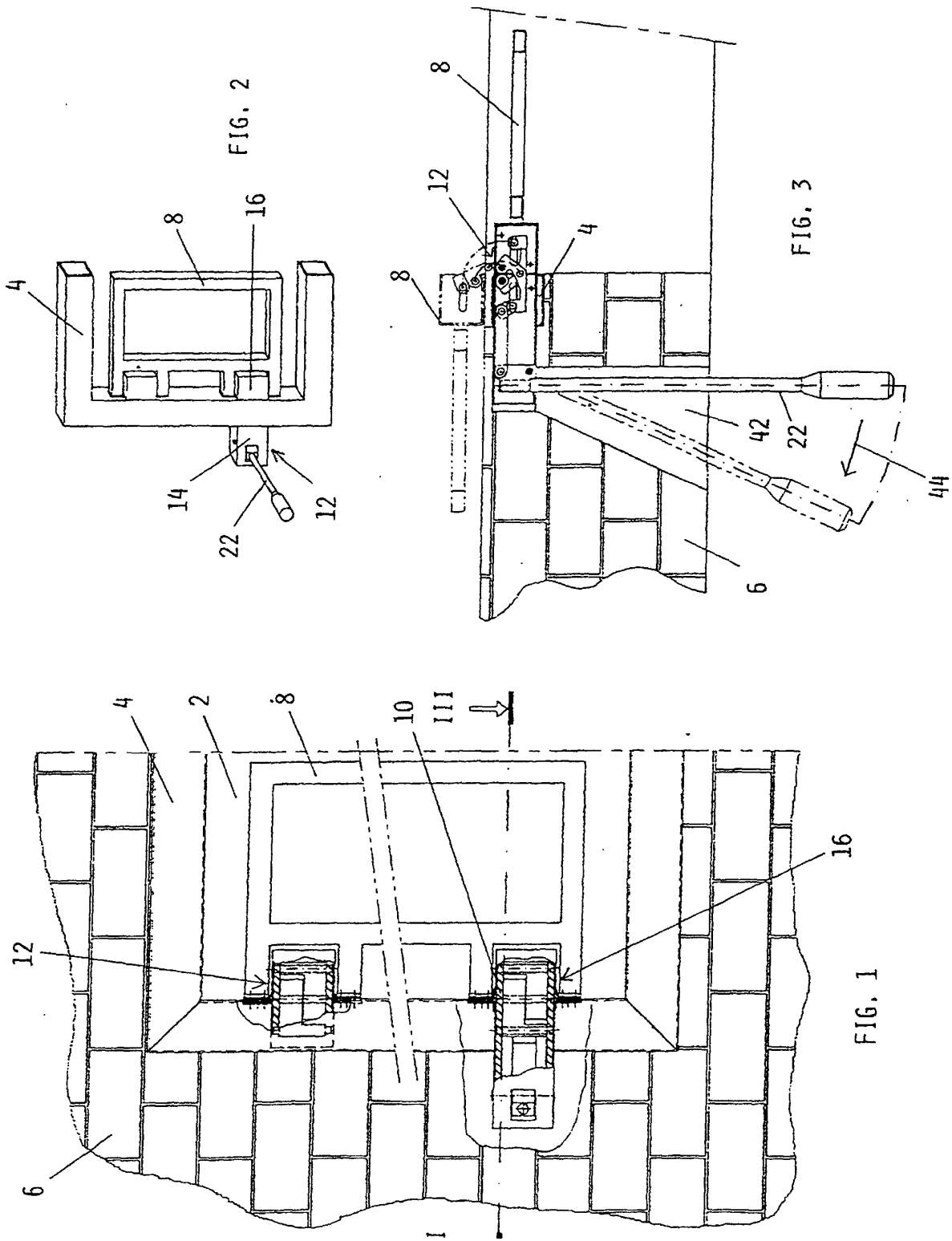



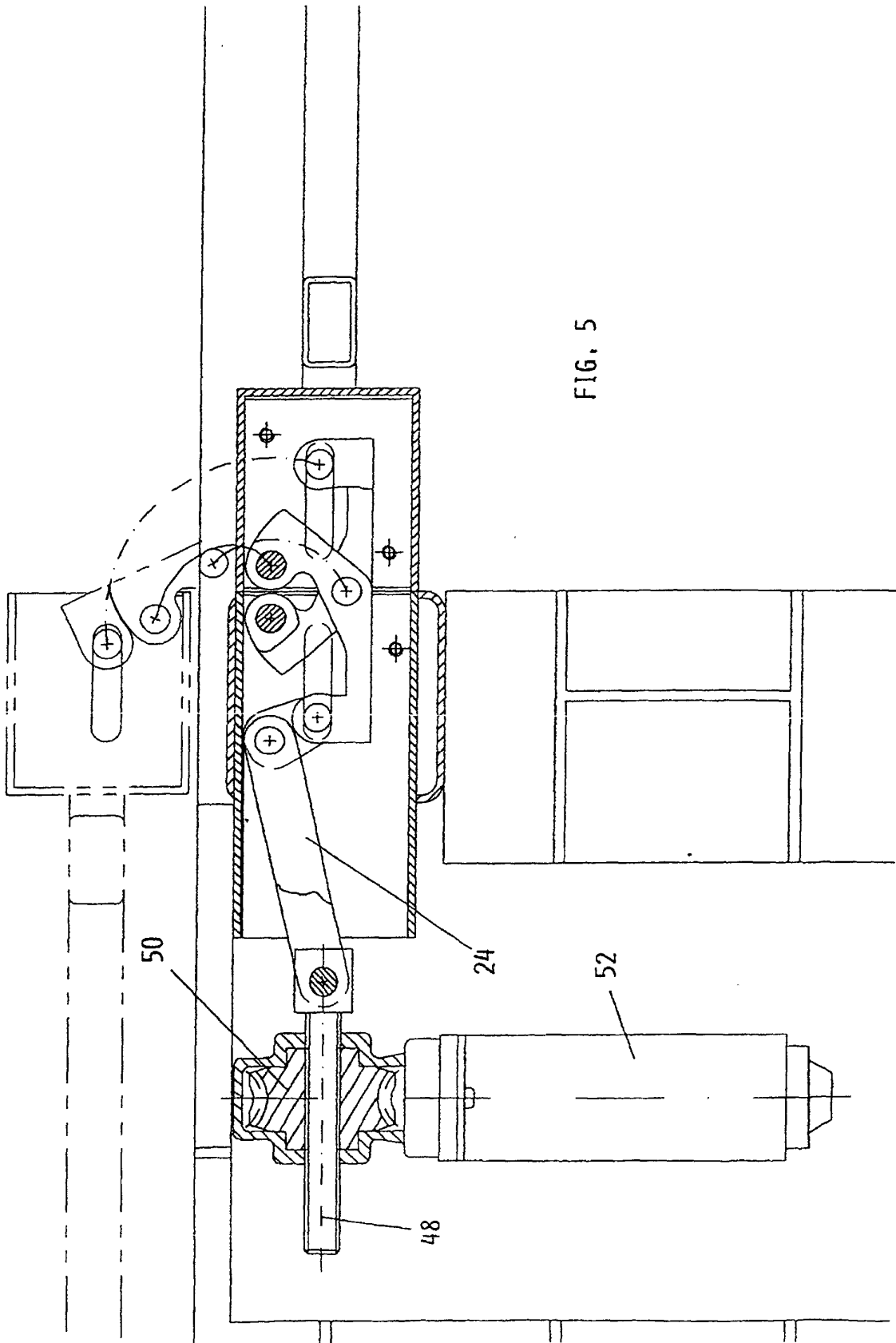
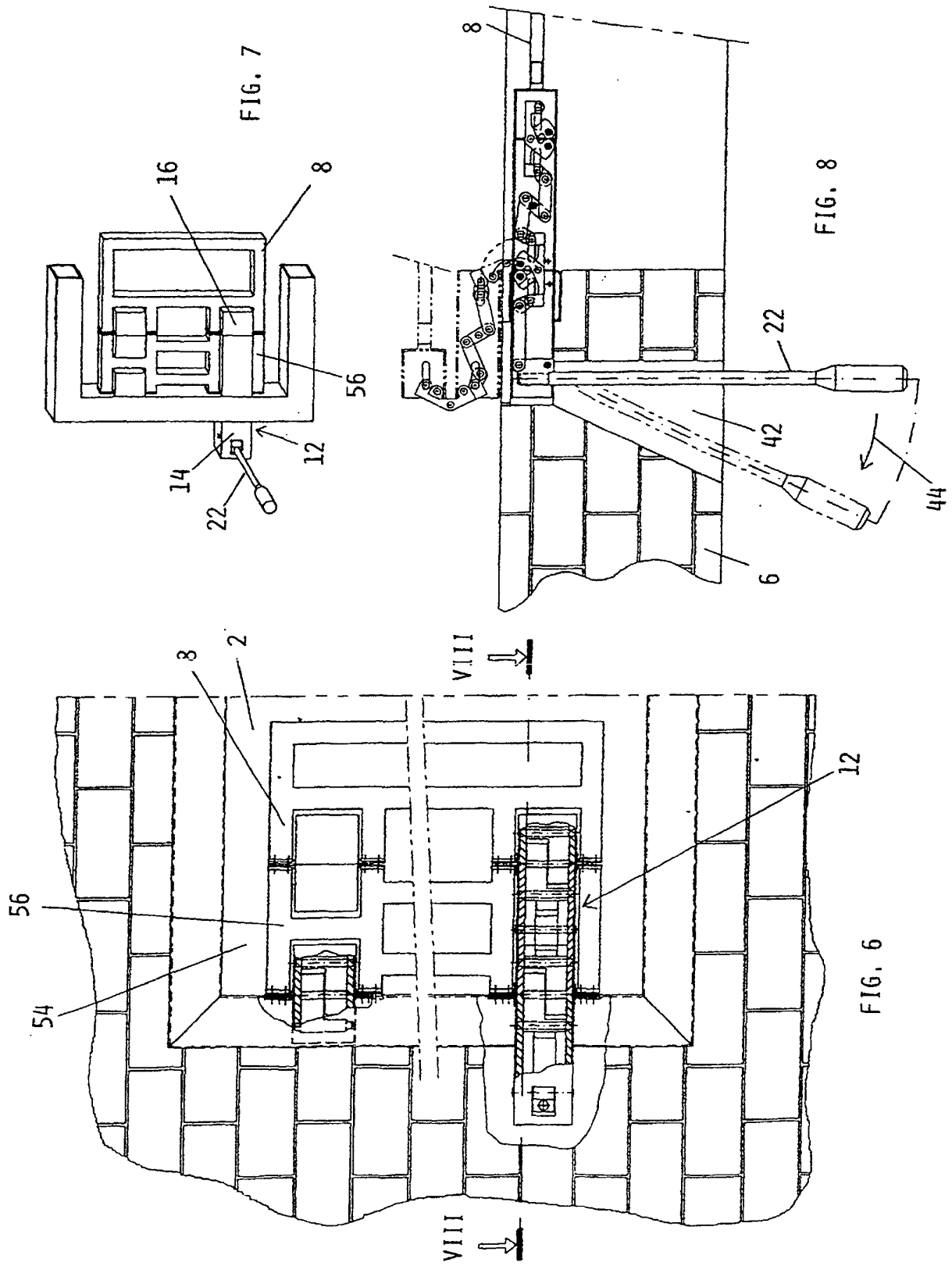

FIG. 5



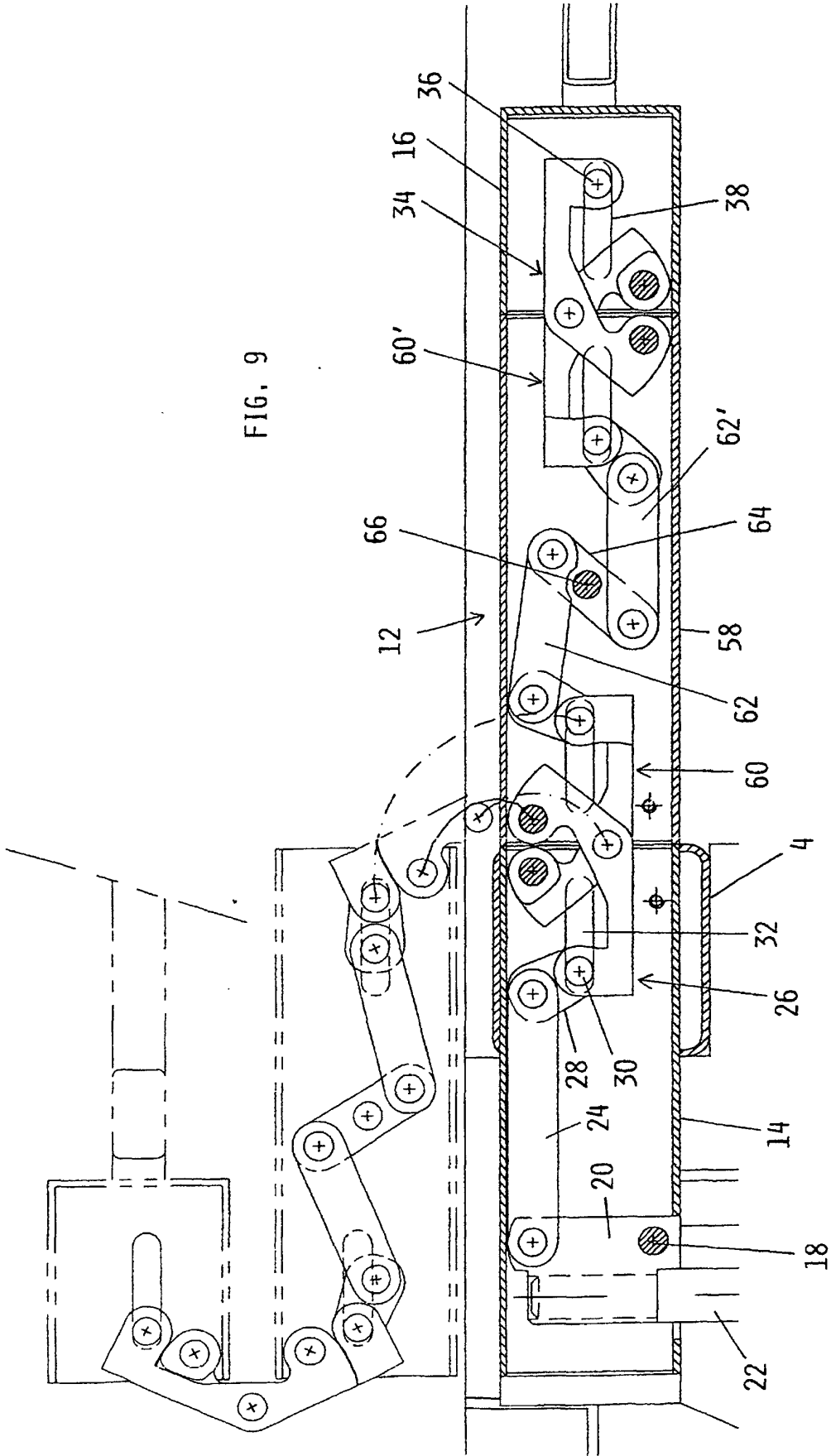

FIG. 9

