



(51) International Patent Classification:

G01V 1/135 (2006.01) G01V 1/38 (2006.01)
G01V 1/145 (2006.01)

(21) International Application Number:

PCT/US2015/016617

(22) International Filing Date:

19 February 2015 (19.02.2015)

(25) Filing Language:

English

(26) Publication Language:

English

(30) Priority Data:

61/942,001 19 February 2014 (19.02.2014) US

(71) Applicant: **BP CORPORATION NORTH AMERICA INC.** [US/US]; 501 Westlake Park Boulevard, Houston, TX 77079 (US).

(72) Inventors: **DELLINGER, Joseph, Anthony**; 150 West Warrenville Road, MC 200-1W, Naperville, IL 60563 (US). **HARPER, Mark, Francis, Lucien**; 150 West Warrenville Road, MC 200-1W, Naperville, IL 60563 (US). **OPENSHAW, Graham, Anthony**; 150 West Warrenville Road, MC 200-1W, Naperville, IL 60563 (US).

(74) Agent: **HEINISCH, Gunnar**; BP America Inc., 150 West Warrenville Road, MC 200-1W, Naperville, IL 60563 (US).

(81) Designated States (unless otherwise indicated, for every kind of national protection available): AE, AG, AL, AM, AO, AT, AU, AZ, BA, BB, BG, BH, BN, BR, BW, BY,

BZ, CA, CH, CL, CN, CO, CR, CU, CZ, DE, DK, DM, DO, DZ, EC, EE, EG, ES, FI, GB, GD, GE, GH, GM, GT, HN, HR, HU, ID, IL, IN, IR, IS, JP, KE, KG, KN, KP, KR, KZ, LA, LC, LK, LR, LS, LU, LY, MA, MD, ME, MG, MK, MN, MW, MX, MY, MZ, NA, NG, NI, NO, NZ, OM, PA, PE, PG, PH, PL, PT, QA, RO, RS, RU, RW, SA, SC, SD, SE, SG, SK, SL, SM, ST, SV, SY, TH, TJ, TM, TN, TR, TT, TZ, UA, UG, US, UZ, VC, VN, ZA, ZM, ZW.

(84) Designated States (unless otherwise indicated, for every kind of regional protection available): ARIPO (BW, GH, GM, KE, LR, LS, MW, MZ, NA, RW, SD, SL, ST, SZ, TZ, UG, ZM, ZW), Eurasian (AM, AZ, BY, KG, KZ, RU, TJ, TM), European (AL, AT, BE, BG, CH, CY, CZ, DE, DK, EE, ES, FI, FR, GB, GR, HR, HU, IE, IS, IT, LT, LU, LV, MC, MK, MT, NL, NO, PL, PT, RO, RS, SE, SI, SK, SM, TR), OAPI (BF, BJ, CF, CG, CI, CM, GA, GN, GQ, GW, KM, ML, MR, NE, SN, TD, TG).

Declarations under Rule 4.17:

- as to applicant's entitlement to apply for and be granted a patent (Rule 4.17(ii))
- as to the applicant's entitlement to claim the priority of the earlier application (Rule 4.17(iii))

Published:

- with international search report (Art. 21(3))
- before the expiration of the time limit for amending the claims and to be republished in the event of receipt of amendments (Rule 48.2(h))

(54) Title: COMPACT SEISMIC SOURCE FOR LOW FREQUENCY, HUMMING SEISMIC ACQUISITION

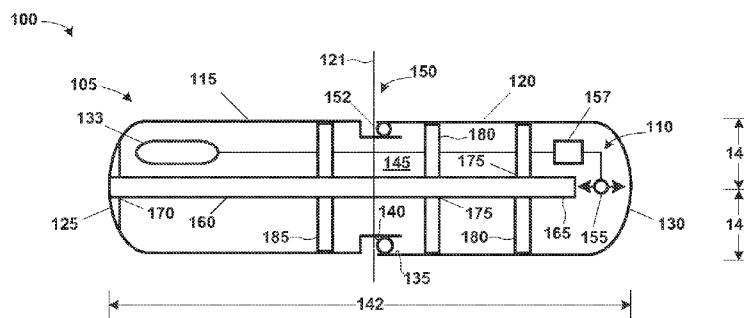
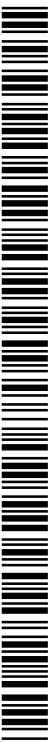

FIG. 1

(57) Abstract: A compact seismic source for seismic acquisition generating a humming signal includes a casing and a low-frequency reciprocating drive. The casing defines a fluid tight chamber and comprises a first casing section and a second casing section of roughly equal mass. The drive is disposed within the fluid tight chamber and, in operation, reinforces the natural reciprocating oscillation of the first and second casing sections relative to one another at a low seismic frequency. In one aspect, this action omnidirectionally radiates the low frequency, humming seismic signal. On another aspect, the compact seismic source is substantially smaller than the wavelength of the low seismic frequency. Such a compact source may be deployed to omnidirectionally radiate a low frequency, humming seismic signal during a seismic survey.



COMPACT SEISMIC SOURCE FOR LOW FREQUENCY, HUMMING SEISMIC ACQUISITION

CROSS-REFERENCE TO RELATED APPLICATIONS

[0001] This application claims priority, under 35 U.S.C. §119(e), of Provisional Application No. 61/942,001, filed February 19, 2014, incorporated herein by this reference.

DESCRIPTION OF THE INVENTION

Field of the Invention

[0002] The present invention pertains to marine seismic sources and, more particularly, to a compact seismic source for low frequency, single frequency, seismic acquisition.

Background of the Invention

[0003] A relatively recent development in seismic acquisition is low-frequency acquisition at a single frequency. This is sometimes referred to as a “humming acquisition”. More precisely, “humming” is using a non-impulsive controlled-frequency source that generates substantially all of its energy at a single frequency. Due to practical stability limitations the source may instead perform a controlled or uncontrolled drift within a narrow frequency range, typically staying within plus or minus one tenth of an octave around the nominal frequency. This is sometimes what is called “monochromatic” or “near monochromatic”, for example in U.S. Application Serial No. 13/327,524.

[0004] Humming acquisition may occur in several different ways. For example, stepped humming is a sequential humming acquisition in which a single source steps over a set of two or more discrete frequencies, one at a time. The time spent moving

between frequencies should be very small compared to the time spent at each frequency. Chord humming is a humming acquisition in which one or more sources simultaneously hum at differing, discrete frequencies. More information is available in U.S. Application Serial No. 13/327,524.

[0005] Seismic sources such as those presented in the aforementioned application are suitable for their intended purpose. However, the art is always receptive to improvements or alternative means, methods and configurations. The art will therefore well receive the seismic source described herein.

BRIEF DESCRIPTION OF THE DRAWINGS

[0006] The accompanying drawings, which are incorporated in and constitute a part of this specification, illustrate embodiments of the invention and together with the description, serve to explain the principles of the invention. In the figures:

[0007] Figure 1 depicts one particular embodiment of a low frequency, single frequency seismic source.

[0008] Figure 2 illustrates seismic acquisition using the seismic source of Figure 1 in one particular embodiment.

[0009] Figure 3A-Figure 3B graph selected aspects of the performance of the seismic source in Figure 1.

[0010] Figure 4A-Figure 4C graphically illustrate selected aspects of design tradeoffs for the seismic source in Figure 1.

[0011] Figure 5A-Figure 5C depict one particular embodiment of a low frequency, single frequency seismic source.

[0012] Figure 6A-Figure 6C illustrate one particular embodiment including a valving system to allow stepwise control of the internal compressible gas volume of the seismic source in Figure 1.

[0013] Figure 7 depicts another particular embodiment of a low frequency, single frequency seismic source alternative to that shown in Figure 1 and in Figure 5A-Figure 5B and Figure 5C.

DESCRIPTION OF THE EMBODIMENTS

[0014] Reference will now be made in detail to the present embodiment(s) (exemplary embodiments) of the invention, an example(s) of which is (are) illustrated in the accompanying drawings. Wherever possible, the same reference numbers will be used throughout the drawings to refer to the same or like parts.

[0015] Turning now to Figure 1, one particular embodiment of a low frequency, humming, compact seismic source 100 is shown. A compact source is a term used by those versed in the art of acoustics and in the present context to denote a source whose dimensions are much less than the smallest wavelength of its emitted signal and which consequently radiates omni-directionally in a homogeneous isotropic fluid such as the water in which a marine seismic survey is conducted.

[0016] The term “humming” does not mean in this context that the seismic source is capable of producing seismic signals of only a single frequency, although that may be the case in some embodiments. It instead refers to a mode of operation in which the seismic source emits signals of only a single frequency for a limited duration at some point in its operation. That is, at some point in its operation, a non-impulsive controlled-frequency seismic source generates substantially all of its energy at a single frequency for a limited duration. In one embodiment, “substantially all of its energy” means 95% of its energy within ± 0.1 octave. The duration will typically be sufficiently long that its inverse exceeds the frequency resolution

required for the task in hand and will be much longer than one cycle of the emitted signal.

[0017] For example, the discussion of humming acquisition set forth above contemplates an acquisition in which the source steps over a set of two or more discrete frequencies, one at a time. Such a source is considered a humming source within the context of this disclosure because it emits signals of only a single frequency for intervals of time much longer than the period of the seismic signal during its operation. This is true even though it does so more than once employing more than one frequency at different times.

[0018] Note also that “low frequency” is “low” as considered within the seismic surveying art. In this context, “low frequency” is less than about 6-8 Hz and, more typically, less than about 4 Hz. The term “about” is a recognition that in acquisition seismic sources may come out of calibration or be poorly calibrated, simultaneously radiate at additional frequencies (for example from harmonics or from noise from a compressor), or that their signals can drift or in other ways deviate from what is desired. Thus, the term “about” means that the actual frequency is within the operational error acceptable to those in the art relative to the desired frequency of acquisition.

[0019] Returning to Figure 1, the seismic source 100 is, more particularly, a compact seismic source. The seismic source 100, in operation, generates a signal of primarily a single frequency at any time. That is, the seismic source 100 is a “humming” source as humming is described above. The seismic source 100 comprises a casing 105 and a low-frequency reciprocating drive 110 disposed within the casing 105 in a manner described more fully below.

[0020] The casing 105 is comprised of two casing sections 115, 120. They are constructed of conventional materials well known to those in the art. The first and second casing sections 115, 120, when assembled, are of roughly equal mass. What constitutes “roughly equal” may vary from embodiment to embodiment because equal masses give the lowest possible resonant frequency for a given overall size and mass of the seismic source 100 as a whole. Thus, embodiments in which the seismic source 100 emits lower frequencies will seek to have more equal masses while embodiments emitting less low frequencies may tolerate greater inequality in the masses. In the illustrated embodiments, the two masses are within $\pm 10\%$ of one another.

[0021] Each of the sections 115, 120 includes a respective domed end 125, 130 on the end most distal from the mid-point of the seismic source 100. In the illustrated embodiments the domed ends 125, 130 are “hemispherical”. The ends 125, 130 are domed (*i.e.*, have smooth convex profiles) to reduce hydrodynamic drag during reciprocation. In general, if the dome is considered as being half an ellipsoid of rotation with the major axis as the axis of rotation, and with that axis along the axis of the source, the larger the ratio of major to minor axis (*i.e.*, the more pointed the ellipsoid), the less the drag.

[0022] However, other considerations mitigate for the hemispherical design of the domes. For example, the hemispherical shape is easy to manufacture and gives most of the drag reduction without causing problems of side-loading if the device is at an angle to the tow direction. Additional information regarding the shape of the domed ends 125, 130 may be found in U.S. Application Serial No. 12/980,527. Note that alternative embodiments may employ different domed shapes for the ends 125, 130.

[0023] The casing 105 defines a fluid tight chamber 145. The first and second sections 115, 120 are joined by a sliding fluid-tight seal 150 allowing relative motion between the two sections 115, 120. The sliding fluid-tight seal 150 of the embodiment in Figure 1 is defined by the sealing element 152 sliding across the smooth sealing faces 135, 140 of the two sections 115, 120. Note that the outer diameter of the first section 115 is stepped down at the seal 150 to maintain a smooth outer profile for the seismic source 100. While this has a salutary effect on the operation of the seismic source 100, it is not necessary to the practice of the invention.

[0024] The sliding fluid-tight seal 150 may comprise any suitable sealing technique known to the art, providing it permits the sliding engagement of the sections 115, 120. In the illustrated embodiment, the sealing element 152 is a spring-energized polyethylene lip seal such as is known in the art. In other embodiments, the sealing element is an elastomeric lubricated O-ring. The sealing faces 135, 140 are typically surfaced with some kind of chrome alloy or other similar material to provide a smooth hard sealing surface.

[0025] The low-frequency reciprocating drive 110 is disposed within the chamber 145. The disposition should maintain the mass distribution of the sections 115, 120 so that the mass of the two sides across the midline of the seismic source 100 are roughly equal. In the illustrated embodiment, an excitation actuator 155 is disposed in the second casing section 120. The excitation actuator 155 is mechanically linked to a centered push-pull rod 160 at one end 165 thereof. The push-pull rod is affixed to the first casing section 115 at a second end 170 thereof.

[0026] In the illustrated embodiment the push-pull rod 160 is supported by two bearings 175 mounted upon stanchions 180 in the second half 120 and a stanchion

185 in the first half 115. Note that the push-pull rod 160 does not move relative to the first half 115 and so no bearing is needed for the stanchion 185. These types of supports may be omitted in some embodiments.

[0027] The seismic source 100 has a source 133 of compressed gas operationally coupled to the chamber 145. In some embodiments, this gas source may be a gas reservoir of compressed gas housed within the chamber 145 as shown in Figure 1. In other embodiments, the compressed gas reservoir may be housed outside of the seismic source 100, say onboard the tow vessel (not shown), and the compressed gas delivered to the seismic source 100 by way of an umbilical (not shown), for example. With respect to the umbilical, if it attaches to either of the sections 115, 120 it should not impede their reciprocating motion. It will not normally do so if the tow line is close to the vertical at the point of attachment or if the tow line is elastic.

[0028] The compressed gas is used to adjust the internal gas pressure of the seismic source 100 to compensate for gas leaks, temperature changes, and other water conditions. These kinds of adjustments may be desirable to keep the device on its desired resonant frequency while maintaining a desired tow-depth window. In some embodiments, the casing 105 may house a valve mechanism (not shown) to release gas to the external environment, in order to lower the internal gas pressure of the seismic source 100. Alternatively, in some embodiments, the internal pressure in chamber 145 may be lowered by means of a pump (not shown) that can force gas back into the gas reservoir 133.

[0029] The gas may be chosen to be oxygen-free to avoid accidental combustion when under pressure. Nitrogen is preferable to air in this respect, as is known to those versed in the art. Other inert gasses with a lower adiabatic ratio than

nitrogen may also be used to lower the resonant frequency. For example, a gas like sulfur hexafluoride may be used and because of its low adiabatic index it could allow lower frequencies to be achieved.

[0030] More particularly, internal gas spaces of the seismic source 100 are normally pressurised to match the external hydrostatic pressure. This is done by filling these internal spaces with an inert gas. The inert nature of the gas avoids the danger of fire which would increase with pressure if these spaces were filled with air. Nitrogen is a suitable alternative to air.

[0031] The compact seismic source 100 radiates a very low-frequency seismic signal, and its resonant frequency depends inversely on the adiabatic compressibility of the gas within it. That means that the less stiff the gas appears in response to rapid changes of volume, the lower the resonant frequency will be. To this end, it may be advantageous to fill the seismic source 100 with a gas selected for having high adiabatic compressibility.

[0032] This will be directly proportional to the so-called adiabatic index of the gas, which is to say the ratio of its principal specific heat at constant pressure to that at constant volume. This ratio is smaller for gases whose molecules have more degrees of freedom of vibration, being equal to about 1.67 for a monatomic gas, 1.4 for a diatomic gas such as nitrogen, and decreasing asymptotically towards unity for more complicated molecules with many degrees of freedom. For example sulphur hexafluoride is an inert gas with an adiabatic index of about 1.09, or 28% lower than nitrogen.

[0033] A source 100 filled with sulphur hexafluoride will thus have a resonant frequency significantly lower than the same source 100 filled with nitrogen. Those of skill in the art having the benefit of this disclosure will appreciate that mixes of two or

more gasses could also be used, and adjusting the proportions of the gas mixture (for example, by releasing different gasses from two or more gas reservoirs) provides another way to adjust the device's resonant frequency at a given tow depth. Care should be taken in the design of such a device because the speed of sound in a gas is equally dependent on its adiabatic ratio. The internal spaces must be designed to avoid standing acoustic waves within the seismic source 100 since these may interfere with its operation. More specifically if the internal space 145 is close to being an integral number of half-wavelengths long at the intended operating frequency of the source, then the internal gas will present a significant (high value) impedance at this frequency and the natural frequency of the system will shift towards higher frequencies. However, if the internal space 145 is close to being an odd number of quarter-wavelengths long at the intended operating frequency of the source then the internal gas will present a very low value impedance at this frequency and the natural frequency of the system will shift towards lower frequencies.

[0034] Some embodiments may also implement short-term, minor adjustments of the frequency by adjusting the phase of the feedback of the excitation actuator 155. This control may be exerted by an electronic controller 157 housed in the chamber 145. In this particular embodiment, the electronic controller 157 includes a power source and associated electronics not otherwise shown. The electronic controller 157 may alternatively be housed outside the seismic source 100, perhaps on the tow vessel, and transmitted to the seismic source 100 via, for example, an umbilical.

[0035] The depiction of the electronic controller 157 and the compressed gas source 133 in Figure 1 is conceptual only. The placement, construction, and

mounting of the electronic controller 157 and the compressed gas source 133 are subject to the design considerations mentioned. Examples of these considerations include, for example, weight distribution and water tightness for the seismic source 100 as a whole. Those in the art having the benefit of this disclosure will appreciate these considerations and how to deal with them in a given implementation.

[0036] Some embodiments may also include one or more interior compartments (not shown in Figure 1; an example is shown in 620), or auxiliary external gas spaces (not shown), that could be sealed off from the space 145 or opened to it by servo or hydraulically controlled valves (not shown in Figure 1; an example is shown in 605), allowing the resonant frequency to be controlled by changing the compressibility of the gas volume defined thereby. This mechanism would provide a way to quickly jump back and forth between two or more frequencies while keeping the seismic source 100 at an approximate constant depth. Smaller changes in volume could be used to re-center the central resonant frequency as needed, allowing the compressed-gas reservoir to be tapped less frequently. The compartments/gas spaces could be organized into a “powers of 2” hierarchy so that a wide range of resonant frequencies could be specified by opening and closing various combinations of compartments.

[0037] As is apparent from the discussion above, the frequency of the marine seismic source will depend on, among other factors, the volume of gas that it contains. The frequency will depend inversely on the square root of this volume. This dependence comes about because of the variation in pressure of the gas as the two sections 115, 120 of the casing 105 move relative to one another. The source frequency will depend on the rate at which this pressure changes with casing

position. It is therefore possible to change the frequency by changing the volume of gas whose volume changes with casing displacement.

[0038] Consider the embodiment of 600 in Figure 6A-Figure 6C. The change in gas volume may be effected by introducing gas-tight bulkheads 605 into each half 115, 120 of the casing 105 with large ports 610. The ports 610 may be opened or closed to either allow free flow of gas across the bulkhead 605 if open or to prevent flow if closed. Any such bulkhead 605 should be stiff enough to prevent it from bowing significantly in response to the difference in gas pressures on its two faces that will occur when the casing sections 115, 120 move. The areas and shapes of the ports 610 must be such as to present negligible flow resistance to the gas when they are open.

[0039] A suitable arrangement of bulkheads 605 is conceptually illustrated in Figure 6A. Each of the casing sections 115, 120 has its internal volume 615 divided in two parts 620 by a bulkhead 605. Each bulkhead 605 is penetrated by the push-pull rod 160 which passes through a seal 625 allowing it to move axially with little or no resistance in a manner well known to those versed in the art.

[0040] When the ports 610 are open, the resonant frequency of the source 600 is negligibly affected by the presence of the bulkheads 605. When the ports 610 of one bulkhead 605 are closed and those of the other are open, the internal gas volume whose volume varies with the motion of the casing 105 is effectively reduced by a quarter, which increases the resonant frequency by a factor of $\sqrt{\frac{4}{3}}$ relative to the frequency when all ports 610 are open. If the ports 610 in both bulkheads 605 are closed, the resonant frequency is increased by a factor of $\sqrt{2}$ compared to its value when all ports 610 are open.

[0041] The bulkheads 605 and the ports 610 may for example be shaped as follows: A bulkhead 605 consists of a flat disc 630 with two port apertures 635 as shown in Figure 6B. A rotor 640, shown in Figure 6C, is mounted co-axially with and in contact with the bulkhead 605. The rotor 640 rotates so that its wings 645 cover the port apertures 635 at two angular positions and leave them clear at two others. In the closed position, the rotor 640 seals the port apertures 635 against fluid flow therethrough. In combination, the bulkhead 605 and rotor 640 form a valve 650 that, when in the open positions, allows flow through an area approaching half the area of the disc 630.

[0042] In the illustrated embodiment, the port apertures 635 are shaped like what might be called "truncated wedges". Alternative embodiments might choose other shapes for the port apertures 635. For example, some embodiments might shape the port apertures as circles or ovals and still other shapes might be used. The design of the rotor 640 might also be changed to accommodate the change in the shape of the port apertures 635 in these embodiments.

[0043] In an alternative embodiment (not shown), casing 145 contains interior compartments that do not extend across the push-pull rod 160, eliminating the need for seals 625. In this embodiment one or more bulkheads 605 control whether or not the gas inside an interior compartment is in fluid communication with internal space 145. An interior compartment disposed in this way is particularly suitable for making smaller adjustments to the compressible gas volume (i.e. a few percent, instead of the 25 percent for the axially disposed bulkheads shown in Figure 6A). Larger adjustments may be achieved if there are multiple internal spaces, each controlled by bulkhead(s), and these are used additively.

[0044] Referring back to Figure 1, in the illustrated embodiment, an umbilical (not shown) is fitted to the seismic source 100. Compressed gas and various control signals are sent to the seismic source 100 and its components via this umbilical. Similarly, outputs from a number of sensors used to detect relative position and other parameters, for example, are transmitted back up to the surface through the umbilical.

[0045] In an embodiment, the two sections 115, 120 of the seismic source 100 will naturally vibrate at a resonant frequency defined chiefly by their masses plus the added mass of entrained fluid and the reciprocal of the compressibility of the gas space 145. The excitation actuator 155, in operation, pushes and pulls the first section 115 relative to the second section 120 in a manner that reinforces that natural reciprocating oscillation. That is, the excitation actuator 155 operates and is controlled to operate to ensure that two sections 115, 120 oscillate at the natural, resonant frequency of the seismic source 100. This causes the seismic source 100 radiate a low frequency, single-frequency seismic signal at the natural resonant frequency of the two sections 115, 120.

[0046] The resonant frequency of the two sections 115, 120 is a function of the depth at which the seismic source 100 is towed because the compressibility of the gas in the space 145 depends inversely on its pressure which will be equal to the hydrostatic pressure of the surrounding fluid. The resonant frequency of the seismic source 100 therefore can be controlled by adjusting the tow depth. Changing the depth will change the hydrostatic pressure to which the seismic source 100 is subjected. This will, in turn, affect the relative positions of the two sections 115, 120.

[0047] More particularly, if left uncontrolled, the relative positions of the sections 115, 120 will change in response to depth changes in such a way that the

internal pressure of the seismic source 100 stays equal to the external, hydrostatic pressure. Note that if depth changes sufficiently, the responsive position change could continue in some circumstances until the seal 150 reaches the end of its travel. Hard stops (not shown) will therefore normally be provided to prevent the two sections 115, 120 from coming apart or colliding. Accordingly, the mass of gas within the chamber 145 may be controlled to maintain the relative positions of the two sections 115, 120 so that the sealing element 152 is maintained near the center of the sliding surface 140. This is one use for the compressed gas source described above.

[0048] The seismic source disclosed herein is dedicated to a low frequency, single frequency type of acquisition. It does not provide signals of the kind known in the art as “broadband swept-frequency” signals. Accordingly, the design can be considerably simplified and the device lightened by omitting elements of broadband sweeping sources and its size compacted. Of particular note is eliminating the variable-stiffness gas spring and associated squeeze piston(s) used in broadband sweeping acquisition as shown in U.S. Application Serial No. 12/995,763.

[0049] One advantage of the size of the compact seismic source 100 is that it radiates the seismic signals it emits “omni-directionally” as is the signal 200 shown in Figure 2. More particularly, the seismic source 100 radiates an acoustic seismic signal 200 omni-directionally because it is much smaller than the wavelengths of the frequencies that it radiates. Note, however, that the wavelengths of the signal being radiated (380m or greater) are so large that the seismic source 100 could be several times its likely size and still be a compact, omni-directional, acoustic source. In this particular embodiment, the low-frequency seismic signal 200 is in the range of 0.5-2 Hz. As discussed herein, the signal emitted is omni-directional because it radiates a

signal in all directions (in three dimensional space) at substantially the same frequency and magnitude.

[0050] The operation of the embodiment in Figure 1 is constrained by the sliding length of the sealing face 140, push-pull rod 160 travel, maximum velocity that the sealing element 152 can tolerate, and device volume. The low end of the achievable frequency range will depend on the volume of the space 145 and the masses of the casing halves 115, 120. Assume a volume of order 10 cubic meters and a total mass of order 30 tons. The frequency would vary with depth roughly as shown in Figure 3A. The acoustic output would also vary strongly as shown in Figure 3B, partly because the source, like any compact acoustic source, is a less efficient radiator at lower frequencies and partly because of the surface ghost. A surface ghost is caused by the surface of the water, which acts as an acoustic mirror, causing “ghost” effects in recorded seismic data.

[0051] At frequencies below about 2.4Hz (*i.e.*, depths down to about 180m) the output is limited by push-pull rod 160 stroke and, above this, by seal velocity—*i.e.*, the relative velocity with which the seal attached to the casing moves over the sealing surface of the piston. The scale in Figure 3A-Figure 3B is referenced to dB re 1 μ Pa at 1m, not re 1 μ Pa/Hz, because the seismic source is emitting a continuous signal. To get the output in dB/Hz simply add $20 \log_{10}(T)$ to the scale, where T is the hum duration in seconds.

[0052] The conventional acquisition-geophysicist's measure of dB/Hz, which integrates the total energy in a “shot”, starts to be less meaningful in this single-frequency context in which the signal may emanate for minutes or even hours instead of the 10-16 seconds of a standard airgun repeat interval. Since the seismic source 100 will be competing with continuous random background noise whose

spectrum is measured in power per unit bandwidth, dB re $1\mu\text{Pa}/\sqrt{\text{Hz}}$, it will be more useful to measure the acoustic power divided by its bandwidth. The seismic source 100 should therefore maintain a stable frequency to minimize its bandwidth and thus maximize its power per unit bandwidth.

[0053] The illustrated embodiments achieve frequency stability of 2% or better, which determines the bandwidth. So, for example, the bandwidth is about 0.02Hz for a 1Hz signal, and so on. This assumes that the signals will last longer than the inverse of the bandwidth (*i.e.*, longer than about 50 seconds). Thus, to get the output in dB re $1\mu\text{Pa}/\sqrt{\text{Hz}}$, add $10 \text{Log}_{10}(1/B)$ to the dB figure re $1\mu\text{Pa}$, where B is the bandwidth.

[0054] For example, suppose the embodiment of the seismic source 100 discussed above is operated at 23m depth. This will allow it to emit a single-frequency signal at 1Hz. From Figure 3A, the source would produce 185dB re $1\mu\text{Pa}$ at 1m. Add 17dB to correct for bandwidth and the measure is 202dB re $1\mu\text{Pa}/\sqrt{\text{Hz}}$. Thus, at 1m one would have a signal-to-noise ratio of 102dB if the background noise level were 100 dB re $1\mu\text{Pa}/\sqrt{\text{Hz}}$. This will decline to 13dB at a distance of 30km, based on an assumption of simple spherical spreading. Accordingly, with a stable frequency, the seismic source 100 can generate an adequate signal for seismic acquisition compared to background noise.

[0055] However, other design parameters may also be used to define the output of the seismic source 100. The factors determining its lowest frequency are the masses of the casing halves 115, 120, the area of cross section of the casing half 115 at the sealing face 140, and the casing gas volume 145 (it decreases with increase in either). The constraints on its output amplitude are push-pull rod 160 stroke; sealing element 152 velocity; and the sliding length of the sealing face 140.

For this discussion, the seismic source 100 will be designed to achieve 0.7Hz frequency at 25m. The contour plot in Figure 4A shows how the resonant frequency will behave as a function of the casing radius 141 and casing length 142. The scales run from a radius equal to 0.8-1.6m and a length equal to 6-12m. The individual contour lines give the locus of possible radius/length combinations for a particular frequency. Thus, the embodiment of Figure 1 can achieve 0.7Hz with a length of approximately 9m.

[0056] Note from Figure 4A how little effect the casing radius 141 has on the resonant frequency. This is for two reasons. Firstly, the moving mass consists almost entirely of mechanical mass, with only a small contribution from fluid added mass. Secondly, the mechanical mass has been set to be proportional to casing volume, so that increased casing radius 141 (which increases the spring stiffness of the gas cavity) is compensated by increased mass.

[0057] Turning now to output level, setting the length at 9m and increasing the stroke in proportion to that length (*i.e.* from $\pm 0.2\text{m}$ to $\pm 0.3\text{m}$) to get the frequency right, Figure 4B graphs far-field output (*i.e.*, accounting for the effect of the free-surface ghost) in dB re $1\mu\text{Pa}/\sqrt{\text{Hz}}@1\text{m}$ (*i.e.*, in units allowing comparison with background noise). Figure 4B illustrates that this design at 0.7Hz can very nearly match the output of the previous example discussed above (*i.e.*, relative to Figure 3A-Figure 3B) operating at 1Hz. This can be done without increasing the casing radius 141, and instead increasing the push-pull rod 160 stroke. Alternatively, one could retain the original stroke and increase the casing radius 141, as shown in Figure 4C.

[0058] Some implementations of the embodiment of Figure 1 might impart excessive accelerations on electronics and/or fail to provide a stable location for a

tow point and/or umbilical attachment. An alternative design would have a central stable section with a moving nose on each end. One such design is presented in the embodiments of Figure 5A-Figure 5B. Figure 5B is a side view of the mechanical linkage 515, while Figure 5A shows a top view of the mechanical linkage 515.

[0059] This seismic source 500 differs from the embodiment of Figure 1 in that it includes a stationary section 505 with a tow point 510 to which a tow line 511 may be attached. Note that the first and second sections 115, 120 still reciprocate relative to one another at the sliding fluid tight seal 150. The functional relationship between the stationary section 505 and the first and second sections 115, 120 is governed by the mechanical linkage 515 consisting of hinged struts of lengths carefully chosen to allow section 505 to remain stationary while sections 115,120 reciprocate. In particular, the axes of rotational motion of the hinges 550, 552, 554 must be coplanar and must lie in a plane parallel to the direction of relative motion of the sections 115,120 and osculating the cylindrical surface of the stationary section 505. Note that the mechanical linkage 515 illustrated is but one means by which the stationary section 505 may be functionally tied to the first and second sections 115, 120 and other means may be used in alternative embodiments.

[0060] In one embodiment shown in Figure 5C, the source 500 includes an umbilical 520 that attaches to the stationary section 505 through a junction box 525. The umbilical 520 runs from the surface, typically a survey vessel such as the vessel 210 in Figure 2, and includes leads for the compressed gas, control, and power as described above. These are continued from the junction box 525 to a penetration 540 mounted on one of the moving sections 115,120 via highly flexible leads 531-533. These leads 531-533 should not impede the reciprocating motion of the two sections 115, 120 and should be resistant to fatigue caused by the relative motion of

the sections 115, 120, 505. They may for example be coiled. They enter the section 115 or 120 via the penetration 540 and connect to equipment therein. Other considerations, such as water tightness and weight distribution, applicable to embodiments described above, also apply. Note that the umbilical 520 permits the removal of some components found in some embodiments from the depicted source 500 to, for example, the survey vessel.

[0061] Returning to Figure 5A-Figure 5C, not shown therein is ancillary equipment such as hydraulic power supplies and accumulators, electric transformers, *etc.* This ancillary equipment may conveniently be mounted on a skid or other mounting means attached to the central section and situated underneath it. The device would rest on this when on deck or on land.

[0062] Some embodiments, such as the seismic source 700 in Figure 7, may be designed to have more than one degree of freedom of vibration within the frequency range. One may, for example, attach masses 705 (only one indicated) on springs 710 (only one indicated) to one or both sections 115, 120 of the casing 105. The masses could be positioned in annuli that slide along the push-pull rod 160 on linear bearings 715 (only one indicated). Each mass/spring combination will use its own excitation actuator (not shown). Note that these components should be disposed in the chamber 145 evenly enough to maintain the roughly equal masses of the first and second sections 115, 120.

[0063] The masses 705 should be near the center of the device 700 to avoid changing the trim of the device 700. The masses 705 will affect the dynamics of the fundamental resonance, for which other aspects of the design as discussed above should compensate. The masses 705 may also increase negative buoyancy, and so their size should be minimized. If the suspension (*i.e.*, spring 710 plus bearing 715)

is sufficiently low-loss, the masses 705 can be smaller with an increased travel to get the same forces. For example, we could use a mass 705 with a fifth the mass of the casing 105, travelling five times as far, to get the same force on the casing 105. Steel springs are low-loss and linear, and, hence, are well suited.

[0064] This mass/spring mechanism cannot be adjusted once the seismic source 700 is deployed. Thus, if the frequency changes (e.g., if the depth or the mass is changed), they will not track the change and modify their operation accordingly. This could be addressed by using gas springs (not shown), with their equilibrium pressure maintained equal to the pressure in the main gas space so that they do track. However, they will have higher losses than steel springs (seal friction), and they will not be linear. This may make it harder to reduce the oscillating mass by using large travels. It will increase the power of the extra actuators needed to drive the masses. Their frequency may drift as friction heats up the gas in the springs unless the pressure control is very good. It will also mean that to some extent, unwanted higher harmonics will be generated.

[0065] The velocities of the linear bearings 715 will be high. A brass plain bearing may manage a velocity of 6m/s. For higher speeds, magnetic or hydrodynamic bearings might be needed.

[0066] The “transfer impedance” between the two ends of the seismic source 700 (if one end creates a pressure in the water, it acts on the other) may modify the output of the harmonics. It is anticipated that this effect will not be significant.

[0067] The following patent applications and patents are hereby incorporated by reference for those portions that are listed and for the purposes set forth as if set forth verbatim herein.

[0068] U.S. Application Serial No. 13/327,524, entitled, "Seismic Acquisition Using Narrowband Seismic Sources", filed December 15, 2011, in the name of the inventors Joseph A. Dellinger *et al.*, published June 21, 2012, as U.S. Patent Publication 2012/0155217, and commonly assigned herewith for its teachings regarding data acquisition located at ¶¶[0024]-[0040], [0054]-[0059], [0065]-[0088].

[0069] U.S. Letters Patent 8,387,744, entitled, "Marine Seismic Source", and issued March 5, 2013, to BP Corporation of North America as assigned of the inventors Mark Harper *et al.* and commonly assigned herewith, for its teachings regarding the design of the domed ends of the source disclosed therein found in column 6, line 64 to column 8, line 11.

[0070] To the extent that any patent, patent application or paper incorporated by reference herein conflicts with the present disclosure, the present disclosure controls.

[0071] Other embodiments of the invention will be apparent to those skilled in the art from consideration of the specification and practice of the invention disclosed herein. It is intended that the specification and examples be considered as exemplary only, with a true scope and spirit of the invention being indicated by the following claims.

WHAT IS CLAIMED IS:

1. A compact marine seismic source for seismic acquisition generating a humming signal, the source comprising:
 - a casing defining a gas filled fluid tight chamber and comprised of a first casing section and a second casing section of roughly equal mass;
 - a low-frequency reciprocating drive disposed within the fluid tight chamber that, in operation, reinforces the natural reciprocating oscillation of the first and second casing sections relative to one another at a low frequency to omni-directionally radiate a low frequency, humming seismic signal; andwherein a frequency of the source is controlled by adjusting a tow depth of the source.
2. The compact seismic source of claim 1, wherein the first and second sections are joined by a sliding fluid tight seal allowing relative motion.
3. The compact seismic source of claim 1, wherein the first and second casing sections each include a hemispherically-domed end.
4. The compact seismic source of claim 1, wherein the reciprocating drive comprises:
 - an excitation actuator disposed in the first casing section; and
 - a push-pull rod mechanically linked to the excitation actuator at one end thereof and affixed to the second casing section at a second end thereof.

5. The compact seismic source of claim 4, further comprising:
at least one bearing for the push-pull rod disposed in the first casing section;
and
a guide for the push-pull rod disposed in the second casing section.
6. The compact seismic source of claim 1, further comprising:
a gas reservoir operationally coupled to the chamber; and
a controller electrically connected to the gas reservoir and the excitation actuator to control their operation including controlling a resonating frequency for the compact seismic source.
7. The compact seismic source of claim 1, further comprising a plurality of fluid-tight chambers within at least one of the first casing section or second casing section, the plurality of fluid-tight chambers in fluid communication with each other via a controllable valve.
8. The compact seismic source of claim 7, wherein volumes of the fluid-tight chambers are arranged in a powers-of-two distribution.
9. The compact seismic source of claim 1, further comprising masses free to vibrate longitudinally on springs.
10. A compact seismic source for seismic acquisition, generating a humming, low-frequency seismic signal at any one time, the source comprising:
a casing defining a fluid tight chamber and comprised of a first casing section
and a second casing section of roughly equal mass;

a low-frequency reciprocating drive disposed within the fluid tight chamber that, in operation, reinforces the natural reciprocating oscillation of the first and second casing sections relative to one another at a low seismic frequency;

wherein the size of the compact seismic source is substantially smaller than the wavelength of the low seismic frequency;

a gas reservoir operationally coupled to the chamber; and

a controller electrically connected to the gas reservoir and the excitation actuator to control their operation to control a resonating frequency for the compact seismic source.

11. The compact seismic source of claim 10, wherein the first and second sections are joined by a sliding fluid tight seal allowing relative motion.
12. The compact seismic source of claim 10, wherein the first and second casing sections each include a hemispherically-domed end.
13. The compact seismic source of claim 10, wherein the reciprocating drive comprises:
 - an excitation actuator disposed in the first casing section; and
 - a push-pull rod mechanically linked to the excitation actuator at one end thereof and affixed to the second casing section at a second end thereof.
14. The compact seismic source of claim 13, further comprising:
 - at least one bearing for the push-pull rod disposed in the first casing section;
 - and
 - a guide for the push-pull rod disposed in the second casing section.

15. The compact seismic source of claim 10, further comprising a plurality of fluid-tight chambers within at least one of the first casing section or second casing section, the plurality of fluid-tight chambers in fluid communication with each other via a controllable valve.
16. The compact seismic source of claim 15, wherein volumes of the fluid-tight chambers are arranged in a powers-of-two distribution.
17. The compact seismic source of claim 10, wherein the source radiates a humming, low-frequency seismic signal omni-directionally.
18. A method for use in marine seismic surveying, comprising:
deploying a low-frequency seismic source, compact on the scale of the wavelength of its radiated signals, the low-frequency seismic source comprising:
a casing defining a fluid tight chamber and comprised of a first casing section and a second casing section of roughly equal mass, wherein the first and second casing sections each include a hemispherically-domed end; and
a low-frequency reciprocating drive disposed within the fluid tight chamber that, in operation, reinforces the natural reciprocating oscillation of the first and second casing sections relative to one another to generate the low-frequency, humming seismic signal;
generating a humming, low-frequency seismic signal from the low-frequency seismic source;
omni-directionally radiating the humming, low-frequency seismic signal;
deploying a receiver array; and

acquiring seismic data from reflections of the low-frequency seismic signal.

19. The method of claim 18, wherein omni-directionally radiating the low-frequency seismic signal includes omni-directionally radiating a low-frequency seismic signal in the range of 0.5-2 Hz.

20. The method of claim 18, wherein deploying a low-frequency seismic source further comprises:

deploying a gas reservoir operationally coupled to the fluid tight chamber; and

deploying a controller electrically connected to the gas reservoir and the excitation actuator to control their operation.

21. The method of claim 18, wherein deploying the low-frequency seismic source includes deploying a low frequency, seismic source at a depth of 25 meters or greater.

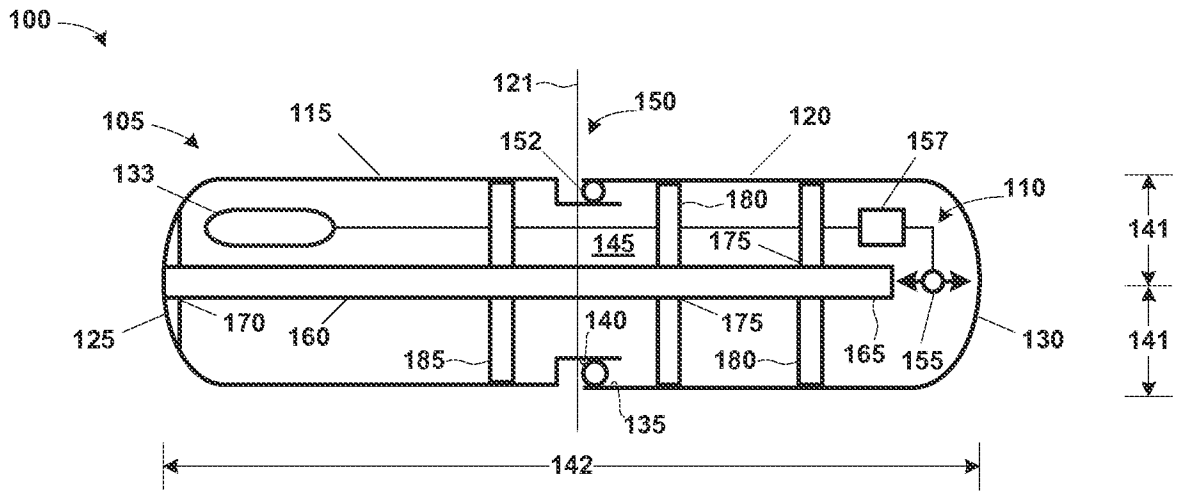

FIG. 1

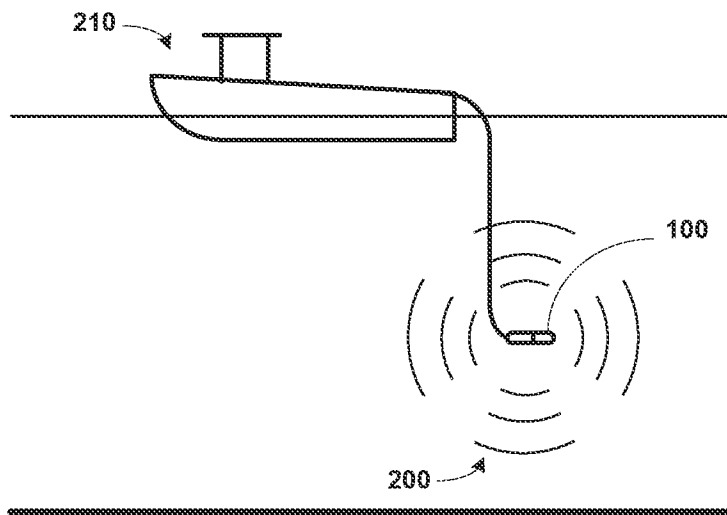

FIG. 2

FREQUENCY VS. DEPLOYMENT DEPTH

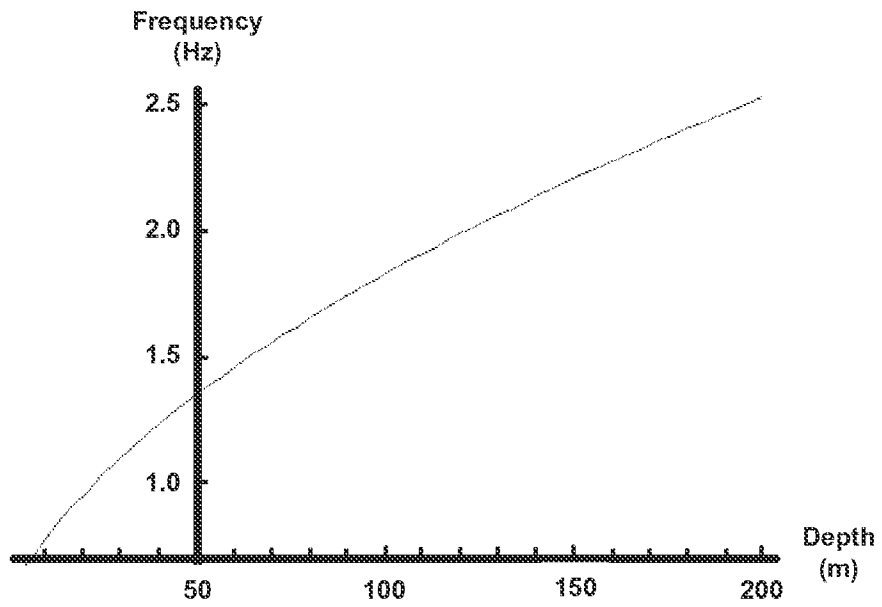

FIG. 3A

FAR FIELD SIGNAL VS. DEPLOYMENT DEPTH

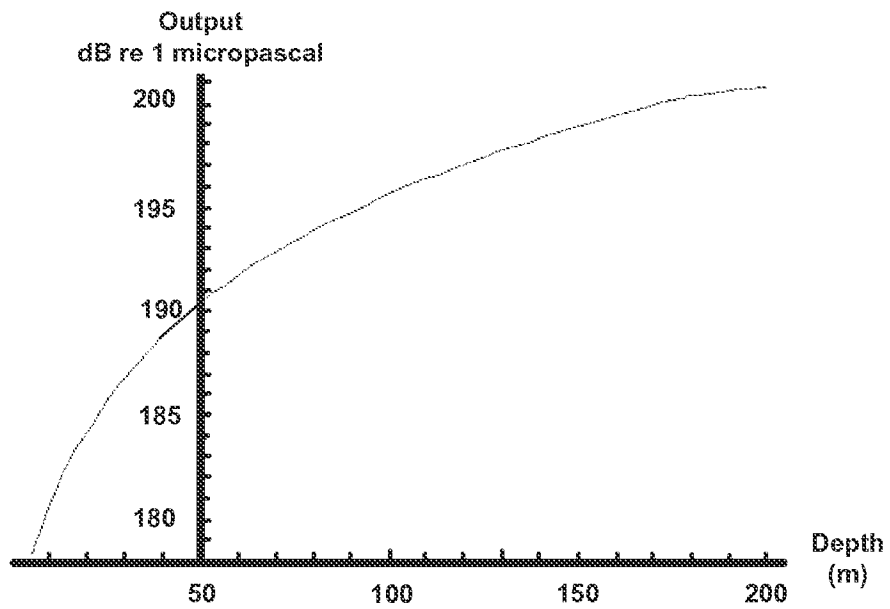

FIG. 3B

FREQUENCY V. PISTON RADIUS & CASING LENGTH

Depth 25m

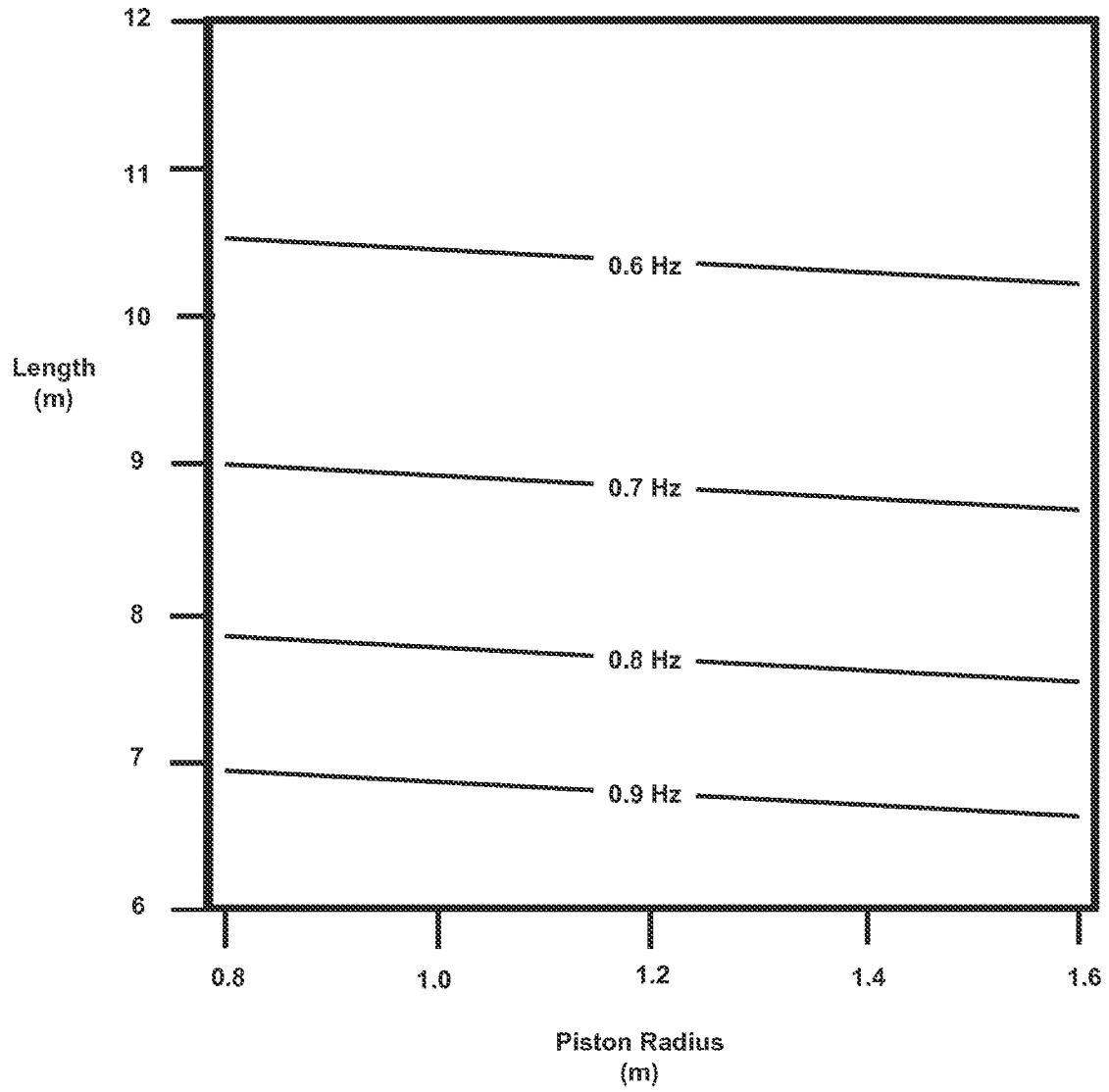

FIG. 4A

FAR FIELD SIGNAL VS. PISTON RADIUS
 Casing Length=9 m Depth=25 m
 Piston Half-Stroke=0.3 m

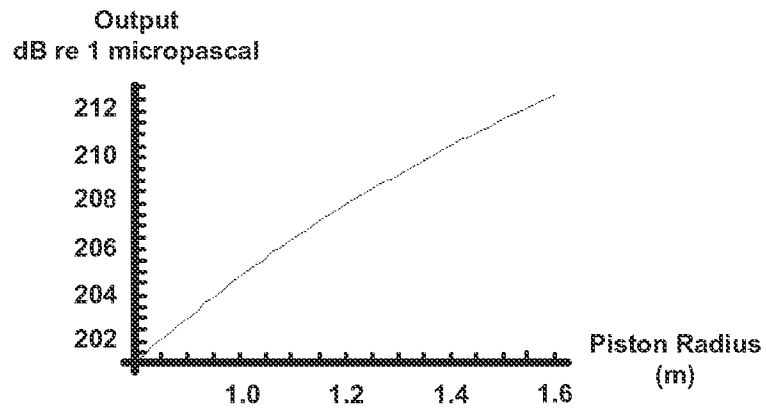

FIG. 4B

FAR FIELD SIGNAL VS. PISTON RADIUS
 Casing Length=9 m Depth=25 m
 Piston Half-Stroke=0.2 m

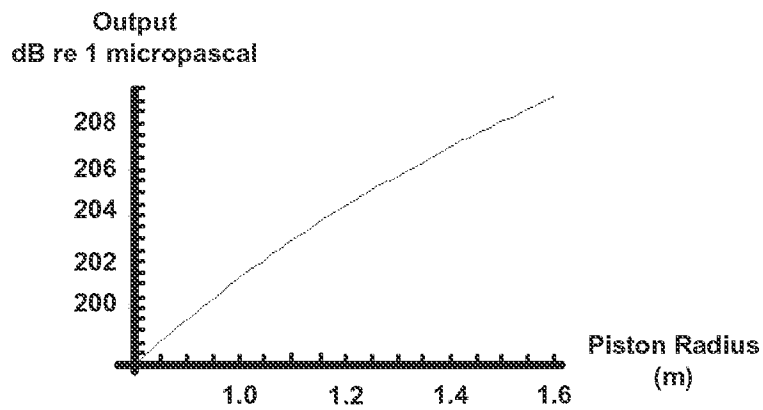

FIG. 4C

5 / 6

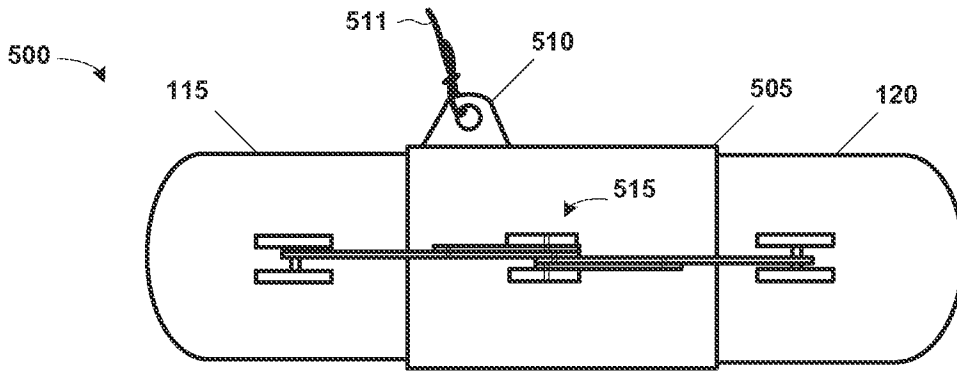

FIG. 5A

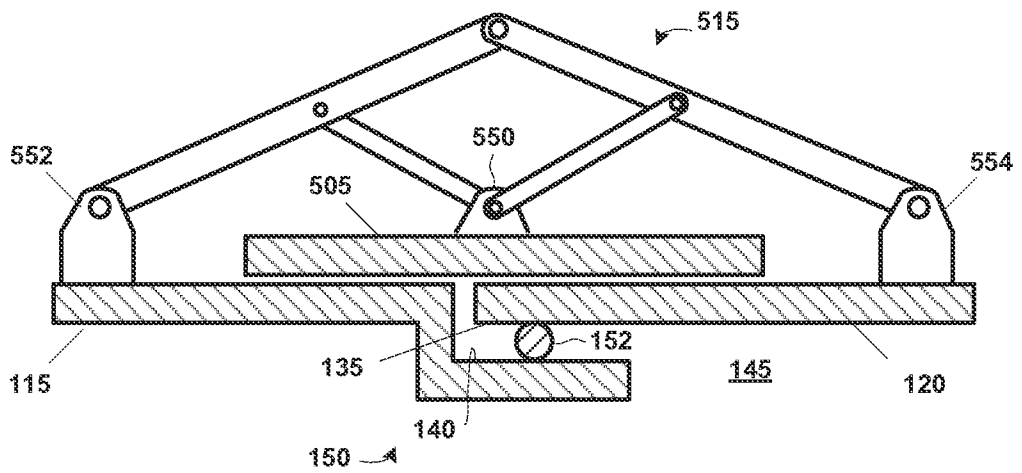

FIG. 5B

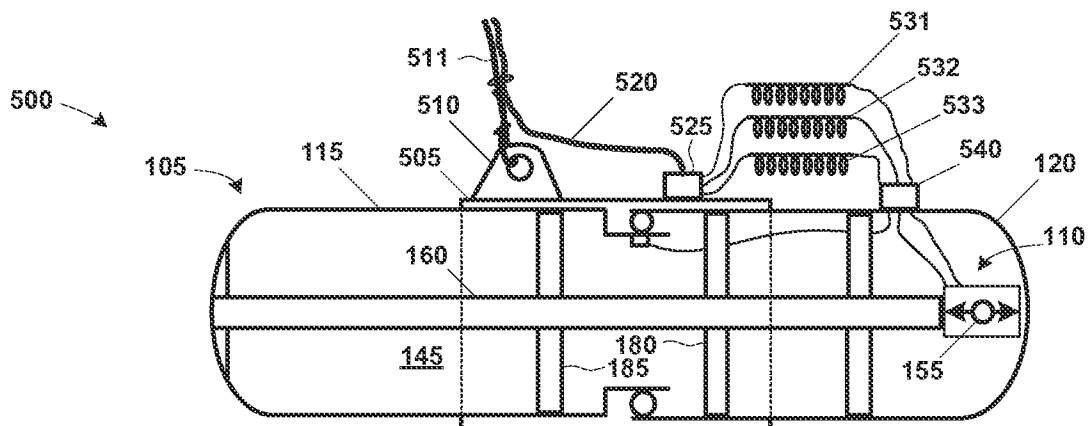

FIG. 5C

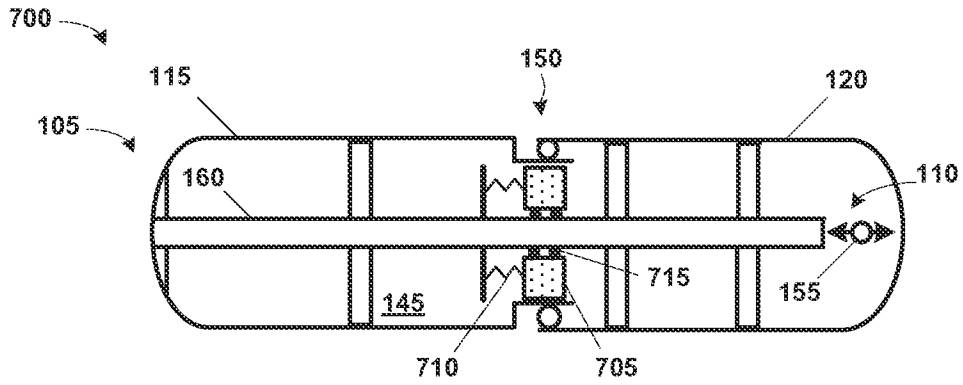

FIG. 7

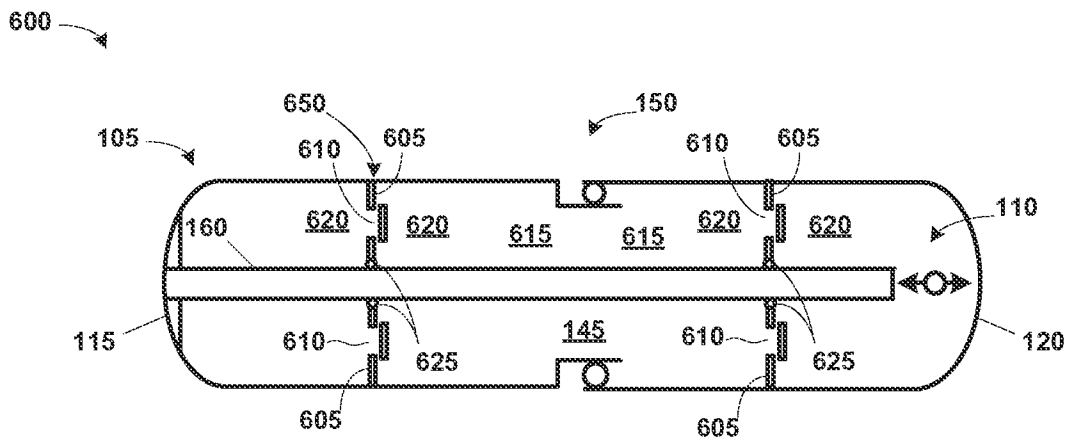

FIG. 6A

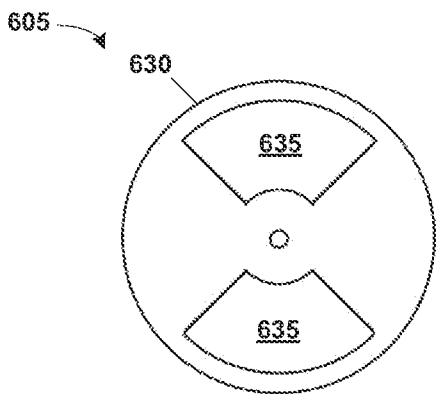

FIG. 6B

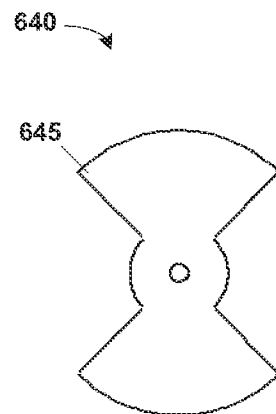

FIG. 6C

INTERNATIONAL SEARCH REPORT

International application No PCT/US2015/016617

A. CLASSIFICATION OF SUBJECT MATTER INV. G01V1/135 G01V1/145 G01V1/38 ADD.				
According to International Patent Classification (IPC) or to both national classification and IPC				
B. FIELDS SEARCHED				
Minimum documentation searched (classification system followed by classification symbols) G01V				
Documentation searched other than minimum documentation to the extent that such documents are included in the fields searched				
Electronic data base consulted during the international search (name of data base and, where practicable, search terms used) EPO-Internal, WPI Data				
C. DOCUMENTS CONSIDERED TO BE RELEVANT				
Category*	Citation of document, with indication, where appropriate, of the relevant passages	Relevant to claim No.		
X	US 6 230 840 B1 (AMBS LORAN D [US]) 15 May 2001 (2001-05-15)	18		
Y	column 1, lines 38-49,64-67 column 2, lines 43-46 column 3, lines 13-25,32-36,46-59 column 5, lines 34-55 abstract claim 8 figures 1A,1C,7	1-17, 19-21		
Y	----- US 5 233 570 A (DONSKOY DIMITRI M [US]) 3 August 1993 (1993-08-03) column 3, lines 10-14	1-9		
Y	----- US 2013/051180 A1 (CHELMINSKI STEPHEN [US]) 28 February 2013 (2013-02-28) paragraphs [0056], [0065], [0069] figures 2A,2B,3,8A,8B,9A -----	6-8, 10-17,20		
-/--				
<input checked="" type="checkbox"/> Further documents are listed in the continuation of Box C. <input checked="" type="checkbox"/> See patent family annex.				
* Special categories of cited documents : <table style="width: 100%; border: none;"> <tr> <td style="width: 50%; border: none; vertical-align: top;"> "A" document defining the general state of the art which is not considered to be of particular relevance "E" earlier application or patent but published on or after the international filing date "L" document which may throw doubts on priority claim(s) or which is cited to establish the publication date of another citation or other special reason (as specified) "O" document referring to an oral disclosure, use, exhibition or other means "P" document published prior to the international filing date but later than the priority date claimed </td> <td style="width: 50%; border: none; vertical-align: top;"> "T" later document published after the international filing date or priority date and not in conflict with the application but cited to understand the principle or theory underlying the invention "X" document of particular relevance; the claimed invention cannot be considered novel or cannot be considered to involve an inventive step when the document is taken alone "Y" document of particular relevance; the claimed invention cannot be considered to involve an inventive step when the document is combined with one or more other such documents, such combination being obvious to a person skilled in the art "&" document member of the same patent family </td> </tr> </table>			"A" document defining the general state of the art which is not considered to be of particular relevance "E" earlier application or patent but published on or after the international filing date "L" document which may throw doubts on priority claim(s) or which is cited to establish the publication date of another citation or other special reason (as specified) "O" document referring to an oral disclosure, use, exhibition or other means "P" document published prior to the international filing date but later than the priority date claimed	"T" later document published after the international filing date or priority date and not in conflict with the application but cited to understand the principle or theory underlying the invention "X" document of particular relevance; the claimed invention cannot be considered novel or cannot be considered to involve an inventive step when the document is taken alone "Y" document of particular relevance; the claimed invention cannot be considered to involve an inventive step when the document is combined with one or more other such documents, such combination being obvious to a person skilled in the art "&" document member of the same patent family
"A" document defining the general state of the art which is not considered to be of particular relevance "E" earlier application or patent but published on or after the international filing date "L" document which may throw doubts on priority claim(s) or which is cited to establish the publication date of another citation or other special reason (as specified) "O" document referring to an oral disclosure, use, exhibition or other means "P" document published prior to the international filing date but later than the priority date claimed	"T" later document published after the international filing date or priority date and not in conflict with the application but cited to understand the principle or theory underlying the invention "X" document of particular relevance; the claimed invention cannot be considered novel or cannot be considered to involve an inventive step when the document is taken alone "Y" document of particular relevance; the claimed invention cannot be considered to involve an inventive step when the document is combined with one or more other such documents, such combination being obvious to a person skilled in the art "&" document member of the same patent family			
Date of the actual completion of the international search	Date of mailing of the international search report			
15 June 2015	19/06/2015			
Name and mailing address of the ISA/ European Patent Office, P.B. 5818 Patentlaan 2 NL - 2280 HV Rijswijk Tel. (+31-70) 340-2040, Fax: (+31-70) 340-3016	Authorized officer Mirkovic, Olinka			

INTERNATIONAL SEARCH REPORT

International application No
PCT/US2015/016617

C(Continuation). DOCUMENTS CONSIDERED TO BE RELEVANT

Category*	Citation of document, with indication, where appropriate, of the relevant passages	Relevant to claim No.
Y	US 3 919 684 A (REED DALE H) 11 November 1975 (1975-11-11) column 3, lines 33-42 column 4, lines 20-37 figures 1-3 abstract -----	3-5, 12-14
Y	US 4 204 278 A (NELSON DAVID E [US]) 20 May 1980 (1980-05-20) column 8, lines 14-31 -----	8,9,16
Y	US 2011/317515 A1 (TENGHAMN STIG RUNE LENNART [US]) 29 December 2011 (2011-12-29) paragraphs [0005], [0025], [0031], [0032], [0043] figures 2,2A -----	9,19-21

INTERNATIONAL SEARCH REPORT

Information on patent family members

International application No PCT/US2015/016617

Patent document cited in search report	Publication date	Patent family member(s)	Publication date
US 6230840	B1	15-05-2001	NONE
US 5233570	A	03-08-1993	NONE
US 2013051180	A1	28-02-2013	CN 103890614 A 25-06-2014
			EP 2748645 A2 02-07-2014
			JP 2014527174 A 09-10-2014
			US 2013051180 A1 28-02-2013
			WO 2013028967 A2 28-02-2013
US 3919684	A	11-11-1975	CA 1011445 A1 31-05-1977
			US 3919684 A 11-11-1975
US 4204278	A	20-05-1980	AU 522100 B2 13-05-1982
			AU 4816979 A 10-01-1980
			CA 1105123 A1 14-07-1981
			DE 2961961 D1 11-03-1982
			DK 279079 A 04-01-1980
			EP 0006768 A2 09-01-1980
			JP S559200 A 23-01-1980
			NO 792144 A 04-01-1980
			US 4204278 A 20-05-1980
			ZA 7903052 A 30-07-1980
US 2011317515	A1	29-12-2011	AU 2011202819 A1 19-01-2012
			BR PI1102801 A2 20-11-2012
			FR 2961902 A1 30-12-2011
			GB 2481707 A 04-01-2012
			GB 2507206 A 23-04-2014
			US 2011317515 A1 29-12-2011