

(19)



(11)

EP 3 715 730 B1

(12)

EUROPEAN PATENT SPECIFICATION

(45) Date of publication and mention of the grant of the patent:

04.12.2024 Bulletin 2024/49

(51) International Patent Classification (IPC):

F24F 1/0011 ^(2019.01) **F24F 1/0047** ^(2019.01)
F24F 13/072 ^(2006.01) **F24F 13/08** ^(2006.01)
F24F 13/14 ^(2006.01) **F24F 13/20** ^(2006.01)

(21) Application number: **20157694.9**

(52) Cooperative Patent Classification (CPC):

(22) Date of filing: **17.02.2020**

F24F 13/072; F24F 1/0011; F24F 1/0047;
F24F 13/081; F24F 13/14; F24F 13/20

(54) **CEILING EMBEDDED AIR CONDITIONER**

IN EINE RAUMDECKE EINGEBETTETE KLIMAAANLAGE

CONDITIONNEUR D'AIR INTÉGRÉ AU PLAFOND

(84) Designated Contracting States:

AL AT BE BG CH CY CZ DE DK EE ES FI FR GB
GR HR HU IE IS IT LI LT LU LV MC MK MT NL NO
PL PT RO RS SE SI SK SM TR

(72) Inventors:

- **SHIGETA, Akihiro**
Osaka, 540-6207 (JP)
- **SHIMIZU, Shougo**
Osaka, 540-6207 (JP)

(30) Priority: **27.03.2019 JP 2019060092**

(74) Representative: **Eisenführ Speiser**

(43) Date of publication of application:
30.09.2020 Bulletin 2020/40

Patentanwälte Rechtsanwälte PartGmbB
Postfach 31 02 60
80102 München (DE)

(73) Proprietor: **Panasonic Intellectual Property Management Co., Ltd.**
Osaka-shi, Osaka 540-6207 (JP)

(56) References cited:

EP-A1- 1 139 034 JP-A- 2006 336 961
JP-A- 2007 024 345 JP-A- H0 886 504

EP 3 715 730 B1

Note: Within nine months of the publication of the mention of the grant of the European patent in the European Patent Bulletin, any person may give notice to the European Patent Office of opposition to that patent, in accordance with the Implementing Regulations. Notice of opposition shall not be deemed to have been filed until the opposition fee has been paid. (Art. 99(1) European Patent Convention).

Description

BACKGROUND OF THE INVENTION

Field of the Invention

[0001] The present invention relates to a ceiling embedded air conditioner.

Description of the Related Art

[0002] As a ceiling embedded air conditioner of this type, there is conventionally known a ceiling embedded air conditioner 100 that is made up, as shown in Fig. 6, of a casing 101 and a decoration panel 105 provided at a bottom surface of the casing 101 and including a plurality of air outlet vents 102, an air inlet vent 103, and air direction deflector plates 104 (refer to, for example, Patent Literature 1, that is, Japanese Patent Laid-Open No. 2000-205642).

[0003] Fig. 7A is a partially cross-sectional view of the conventional ceiling embedded air conditioner described in the patent document described above taken along a line X-X' in Fig. 6, showing a portion near an air outlet vent, which is in use, in the decoration panel. Fig. 7B is a partially cross-sectional view of the conventional ceiling embedded air conditioner described in the patent document described above taken along the line X-X' in Fig. 6, showing a portion near an air outlet vent, which is not in use, in the decoration panel.

[0004] As shown in Fig. 7, an internal air path 102a, an outlet air cut-off member 106, which is provided on an upstream side of the air outlet vent 102 which is not in use, and a substantially flat air direction deflector plate 104, which is provided near a surface of the decoration panel 105 at the air outlet vent 102 so as to close totally the air outlet vent 102 when it is not in use, are provided near each of the air outlet vents 102 in the decoration panel 105, whereby whether the air outlet vents 102 are in use or not can easily be determined from an external appearance of the decoration panel 105, and the direction of air can be adjusted at each of the air outlet vents 102. Thus, the comfortableness for a person and a place can be improved.

[0005] In the conventional configuration described above, however, in a partial cross section near the air outlet vent 102, which is in use, in the decoration panel 105 as shown in Fig. 8, when the air direction deflector plate 104 opens at a small angle, since an air flow W that passes through the internal air path 102a does not flow along a surface Z (a front surface portion) of the air direction deflector plate 104 that is seen from an interior of a room but flows separate from the surface Z, for example, when a cooling operation is performed, there is caused a problem in that condensation is generated on the surface Z due to a difference in temperature between a temperature of the air direction deflector plate 104 that is cooled by cold air and inside air W of high temperature

and high humidity.

[0006] Patent Literature 2 (JP H08-86504) discloses an air conditioning machine having a main body, accommodated in a ceiling, and a panel on which an air outlet port and an air suction port are disposed close to each other. A projection is provided on the inside surface of the air outlet port of a chamber so as to blockade 20% or more of a width of an outlet passage across the whole area of lengthwise direction of the outlet passage.

[0007] Patent Literature 3 (JP 2007-24345) discloses an air conditioner installed on a ceiling and having an indoor unit provided with a plurality of supply openings composed of an inner air trunk wall and an outer air trunk wall, and faced to a lower face, and a suction opening. The air conditioner further comprises vanes respectively mounted on the supply openings for deflecting the direction of the air supplied indoors and having a bent portion bent in the direction separating from the inner air trunk wall at upstream-side portion cassette embedded air conditioner for preventing dew condensation on an outlet at a time of cooling operation by improving a vane (wind deflector) shape and an outlet shape.

SUMMARY OF THE INVENTION

[0008] With a view to solving the problem inherent in the related art ceiling embedded air conditioner, according to an aspect of the present invention, there is provided a ceiling embedded air conditioner as defined in claim 1, including, *inter alia*, an air outlet vent, and in the ceiling embedded air conditioner, the air outlet vent includes an inner air path and an outer air path, the inner air path is made up of a flat surface portion on an upstream side and a curved surface portion on a downstream side, and a plurality of projections are provided at an end portion of the curved surface portion.

[0009] As a result, an air flow colliding with the projection at the air outlet vent generates a longitudinal vortex and flows along a front surface portion (a lower surface side) of the air direction deflector plate.

[0010] Consequently, as in the ceiling embedded air conditioner, an air flow flowing in a substantially vertical direction from an upstream of the air outlet vent is allowed to let out while being guided from the inner air path in the air outlet vent towards the air direction deflector plate.

[0011] Thus, even though an opening area opened by the air direction deflector plate in the air outlet vent is small, that is, the air direction deflector plate opens at a small angle, the air is allowed to flow without separating from the front surface portion (the lower surface side) of the air direction deflector plate.

[0012] With the ceiling embedded air conditioner of the present invention, even though the air direction deflector plate opens at a small angle during a cooling operation, the air is allowed to flow along the air direction deflector plate, whereby the generation of condensation can be prevented which would otherwise be caused by air flowing separate from the front surface portion (the lower

surface side) of the air direction deflector plate during such a cooling operation.

BRIEF DESCRIPTION OF THE DRAWINGS

[0013]

Fig. 1 is a perspective view of a ceiling embedded air conditioner according to a first embodiment of the present invention;

Fig. 2 is a cross-sectional view taken along a line A-A' of the ceiling embedded air conditioner according to the first embodiment of the present invention;

Fig. 3 shows a partially sectional perspective view and a partially enlarged view of an air outlet vent, which is in use, of the ceiling embedded air conditioner according to the first embodiment of the present invention;

Fig. 4 shows a partially sectional perspective view and a partially enlarged view near the air outlet vent in a decoration panel of the ceiling embedded air conditioner according to the first embodiment of the present invention in the cross section taken along the line A-A' in Fig. 1;

Fig. 5 shows a partially sectional perspective view and a partially enlarged view of an air outlet vent, which is in use, of a ceiling embedded air conditioner according to a second embodiment of the present invention;

Fig. 6 is a perspective view of a conventional ceiling embedded air conditioner;

Fig. 7A is a partial cross-sectional view of a conventional ceiling embedded air conditioner taken along a line X-X' in Fig. 6, showing a portion near an air outlet vent, which is in use, in a decoration panel, and Fig. 7B is a partially cross-sectional view of the conventional ceiling embedded air conditioner taken along the line X-X' in Fig. 6, showing a portion near an air outlet vent, which is not in use, in the decoration panel; and

Fig. 8 is an explanatory diagram of an air flow near the air outlet vent in the decoration panel of the conventional ceiling embedded air conditioner in the section taken along the line X-X' in Fig. 6.

DETAILED DESCRIPTION OF THE PREFERRED EMBODIMENTS

[0014] The invention provides a ceiling embedded air conditioner as defined in appended claim 1.

[0015] As a result, the air flow colliding against the projection at the air outlet vent generates a longitudinal vortex and flows along the surface of the air direction deflector plate.

[0016] Consequently, as in the ceiling embedded air conditioner, an air flow flowing in a substantially vertical direction from an upstream of the air outlet vent is allowed to let out while being guided from the inner air path in the

air outlet vent towards the air direction deflector plate, and even though an opening area opened by the air direction deflector plate in the air outlet vent is small, that is, the air direction deflector plate opens at a small angle, the air is allowed to flow without separating from the front surface portion (the lower surface side) of the air direction deflector plate.

[0017] Consequently, even though the air direction deflector plate opens at a small angle during a cooling operation, the air is allowed to flow along the air direction deflector plate, whereby the generation of condensation can be prevented which would otherwise be caused by air flowing separate from the front surface portion (the lower surface side) of the air direction deflector plate during such a cooling operation.

[0018] According to the present invention as defined in claim 1, a surface of each of the plurality of projections includes a plurality of irregular portions that are smaller than the plurality of projections.

[0019] As a result, a resistance generated when the air flow collides against the projection is reduced, and a fine vortex generated near a wall surface of the projection keeps the air flow flowing along the projection, whereby the longitudinal vortex generated on the upstream side is prevented from being combined with a longitudinal vortex generated adjacent thereto.

[0020] Consequently, in particular, even though an air velocity is fast, the longitudinal vortex generated at the projection is ensured to arrive at the air direction deflector plate while reducing the resistance generated by the projection to thereby generate an air flow that flows towards the front surface portion (the lower surface side) of the air direction deflector plate.

[0021] Thus, in particular, even though the air velocity is fast, the air flow is allowed to flow along the air direction deflector plate, whereby the generation of condensation can be prevented which would otherwise be caused by the air flow flowing separate from the front surface portion (the lower surface side) of the air direction deflector plate during a cooling operation.

[0022] According to a further embodiment of the present invention, each of the plurality of projections has an oval shape in which a major axis constitutes a flowing direction when the projection is seen from a normal direction thereof.

[0023] As a result, by adopting the oval shape in which the major axis constitutes the flowing direction, compared with a circular shape, a smaller scaled longitudinal vortex is generated when the air flow collides against the projection, and the air flow is guided by the major axis of the projection.

[0024] Consequently, in particular, even with a low air volume in which a longitudinal vortex is hardly generated, the longitudinal vortex generated at the projection is ensured to be conveyed to the front surface portion (the lower surface side) of the air direction deflector plate.

[0025] Thus, even though the air direction deflector plate opens at a small angle during a cooling operation

particularly with air flowing weakly at a low air velocity, the air is still allowed to flow along the air direction deflector plate, whereby the generation of condensation can be prevented which would otherwise be caused by the air flow flowing separate from the front surface portion (the lower surface side) of the air direction deflector plate during a cooling operation.

[0026] Hereinafter, referring to drawings, embodiments of the present invention will be described. The present invention is not limited by those embodiments.

(First Embodiment)

[0027] Fig. 1 shows a perspective view of a ceiling embedded air conditioner according to a first embodiment of the present invention.

[0028] Fig. 2 shows a cross-sectional view of the ceiling embedded air conditioner according to the first embodiment of the present invention, taken along a line A-A' in Fig. 1.

[0029] Fig. 3 shows a partially sectional perspective view and a partially enlarged view of an air outlet vent, which is in use, of the ceiling embedded air conditioner according to the first embodiment of the present invention.

[0030] Fig. 4 shows a partially sectional perspective view and a partially enlarged view near the air outlet vent in a decoration panel of the ceiling embedded air conditioner according to the first embodiment of the present invention in the cross section, taken along the line A-A' in Fig. 1.

[0031] In Fig. 1, a ceiling embedded air conditioner 1 includes a casing 2 and a decoration panel 6 provided at a bottom surface of the casing 2 and including a plurality of air outlet vents 3, an air inlet vent 4, and air direction deflector plates 5.

[0032] In addition, in Fig. 2, installed in an interior of the ceiling embedded air conditioner 1 are a centrifugal air blower 7, a motor 8 for driving the centrifugal air blower 7, the air inlet vent 4 made up of a grille 4a and a filter 4b, an orifice 9 configured to induct air flows W flowing in from the air inlet vent 4 into the centrifugal air blower 7, a heat exchanger 10 installed in such a manner as to surround the centrifugal air blower 7, a drain pan 11 supporting the heat exchanger 10 and forming parts of internal air paths 3a in the air outlet vents 3 on a side of the casing 2, and an internal insulation material 12 installed on an inner surface of the casing 2 and forming parts of the internal air paths 3a in the air outlet vents 3.

[0033] The ceiling embedded air conditioner 1 is installed in a recessed portion on a ceiling 50 in such a manner as to be suspended from the ceiling 50 with suspension bolts 51.

[0034] As shown in Fig. 3, the air outlet vent 3 includes an inner air path 13, an outer air path 14, the air direction deflector plate 5, and a motor 16 for rotating the air direction deflector plate 5, and the inner air path 13 is made up of a flat surface portion 13a on an upstream side

and a curved surface portion 13b on a downstream side. Then, a plurality of projections 15 are provided at an end portion of the curved surface portion 13b, and each projection 15 has a substantially oval shape in which a major axis constitutes a flowing direction of the air flow W and includes irregular portions 15a provided on a surface thereof, the irregular portions 15a being smaller than the projection 15.

[0035] Then, as shown in Fig. 4, the air direction deflector plate 5 is made up of a front surface portion 5a, a rear surface portion 5b, and a rotational shaft portion 5c to which the motor 16 is connected.

[0036] An operation and a function of the ceiling embedded air conditioner configured as described above will be described as follows.

[0037] At first, as shown in Fig. 2, when the centrifugal air blower 7 is rotated by a motor 8, an air flow W is generated by a difference in pressure between an inside of a room (the atmospheric pressure) and an interior of the ceiling embedded air conditioner 1, and the air flow is inducted into the centrifugal air blower 7 by flowing sequentially through the grille 4a, the filter 4b and the orifice 9 in that order. Thereafter, the air flow W let out from the centrifugal air blower 7 is heated by the heat exchanger 10 for a heating operation and is cooled by the heat exchanger 10 for a cooling operation, whereafter the air flow W passes through the internal air path 3a to be let out into the inside of the room from the air outlet vent 3 that is opened as a result of the rotation of the air direction deflector plate 5.

[0038] In addition, as shown in Figs. 3 and 4, the air direction deflector plate 5 changes not only an opening area in the air outlet vent 3 but also an air blowing direction as a result of the motor 16 being rotated in a rotational direction C.

[0039] Then, when the opening area opened by the air direction deflector plate 5 is small as in a cooling operation, an air flow flowing separate from the front surface portion 5a of the air direction deflector plate 5 by then is changed into an air flow flowing along the front surface portion 5a of the air direction deflector plate 5 by increasing an air flow flowing near the curved surface portion 13b by generating a longitudinal vortex at each projection 15.

[0040] Thus, as has been described above, in this embodiment, as a result of the plurality of projections 15 being provided at the end portion of the curved surface portion 13b, when the opening area opened by the air direction deflector plate 5 is small, an air flow flowing separate from the front surface portion 5a of the air direction deflector plate 5 by then is changed into an air flow flowing along the front surface portion 5a of the air direction deflector plate 5 by increasing an air flow flowing near the curved surface portion 13b by generating a longitudinal vortex at each projection 15.

[0041] Thus, even though the air direction deflector plate 5 opens at a small angle during a cooling operation, the air flow is allowed to flow along the air direction deflector plate 5, whereby the generation of condensa-

tion can be prevented which would otherwise be caused by separation of the air flow from the front surface portion 5a of the air direction deflector plate 5 during a cooling operation.

[0042] Additionally, since force necessary to change the direction of the air flow W is proportional to flow velocity, a flow velocity V_w in this embodiment becomes in the order of $V_w = 1.0L$ to $3.0L$ for a width L of the air outlet vent 3 in Fig. 1.

[0043] Consequently, the projection 15 in this embodiment is given a substantially oval shape in which a major axis constitutes a flowing direction, and for the width L of the air outlet vent 3 shown in Fig. 1, a size of the projection 15 becomes such that a major axis L_1 is $0.005L$ to $0.02L$, a minor axis L_2 is $0.001L$ to $0.01L$, a height h is $0.001L$ to $0.01L$, and an interval P at which the projections 15 are provided in a width direction of the air outlet vent 3 is $0.025L$ to $0.075L$ for the width L of the air outlet vent 3, whereby the flowing direction of the air flow is changed so that the air flow is allowed to flow along the front surface portion 5a of the air direction deflector plate 5 by increasing the air flow flowing near the curved surface portion 13b by generating a longitudinal vortex by the projection 15 without increasing excessively the resistance of the air flow by the projection 15.

[0044] In the invention, since the plurality of irregular portions 15a that are smaller than the plurality of projections are provided on the surface of the projection 15, resistance generated when the air flow collides against the projection 15 is reduced, and the air flow is kept flowing along the projection 15 by a fine vortex generated in the vicinity of a wall surface of the projection 15, whereby a longitudinal vortex generated on an upstream side is prevented from being combined with a longitudinal vortex generated adjacent thereto.

[0045] Consequently, in particular, even when the air velocity is fast, the longitudinal vortex generated at the projection 15 is ensured to arrive at the air direction deflector plate 5 while reducing the resistance by the projection 15, whereby an air flow is generated which flows towards the front surface portion (the lower surface side) 5a of the air direction deflector plate 5.

[0046] Thus, in particular, even when air flows quickly at a fast air velocity, an air flow is allowed to flow along the air direction deflector plate 5, whereby the generation of condensation can be prevented which would otherwise be caused by the separation of the air flow from the front surface portion (a lower surface side) 5a of the air direction deflector plate 5 during a cooling operation.

[0047] Additionally, in this embodiment, the projection 15 is given the substantially oval shape in which the major axis constitutes the flowing direction, whereby compared with a circular shape, a smaller scaled vortex is generated when the air flow collides against the projection 15, and the air flow is guided by the major axis.

[0048] Consequently, in particular, even with a low air volume in which a longitudinal vortex is hardly generated, the longitudinal vortex generated at the projection 15 is

ensured to be conveyed to the front surface portion (the lower surface side) 5a of the air direction deflector plate 5.

[0049] Thus, even though the air direction deflector plate opens at a small angle during a cooling operation particularly with air flowing weakly at a low air velocity, the air is still allowed to flow along the air direction deflector plate, whereby the generation of condensation can be prevented which would otherwise be caused by the air flow flowing separate from the front surface portion (the lower surface side) of the air direction deflector plate during a cooling operation.

[0050] In this embodiment, the intervals P at which the projections 15 are provided are made to be irregular intervals, whereby longitudinal vortexes generated by the projections 15 are made uneven, and a peak in a specific frequency band of noise generated at the air outlet vent 3 is suppressed, thereby making it possible to reduce the noise.

[0051] In this embodiment, the number of projections 15 is not particularly limited, provided that the intervals P are maintained, and longitudinal vortexes are generated at the projections 15 by an amount of air let out from the air outlet vent 3 to increase an air flow flowing in the vicinity of the curved surface portion 13b without increasing excessively a pressure loss of an air flow at each of the projections 15, and the number of air flows whose flowing directions are changed so as to flow along the front surface portion 5a of the air direction deflector plate 5 is changed.

(Second Embodiment)

[0052] Fig. 5 shows a partially sectional perspective view and a partially enlarged view of an air outlet vent, which is in use, of a ceiling embedded air conditioner according to a second embodiment of the present invention. Like reference signs will be given to like or corresponding portions to those of the first embodiment, so that part of a description of the second embodiment is omitted.

[0053] As shown in Fig. 5, a plurality of projections 15 are provided at intervals P at an end portion of a curved surface portion 13b over a distance of $0.3L$ or smaller from opposite sides of an air outlet vent 3.

[0054] An operation and a function of the ceiling embedded air conditioner configured as described above will be described as follows.

[0055] When an opening area opened by an air direction deflector plate 5 is small as in a cooling operation and an air velocity is slow, the Coanda effect (inertial force along a curved surface) at the curved surface portion 13b becomes weak, whereby an air flow flowing along a front surface portion (a lower surface side) 5a of the air direction deflector plate 5 is hardly generated.

[0056] Then, the flowing direction of the air flow flowing separate from the front surface portion 5a of the air direction deflector plate 5 by then is changed in such a way that the air flow flows along the front surface portion

5a of the air direction deflector plate 5 by increasing an air flow flowing in the vicinity of the curved surface portion 13b by generating longitudinal vortexes at the projections 15 provided on the curved surface portion 13b to lie near both the ends of the air outlet vent 3.

[0057] Thus, as has been described heretofore, in this embodiment, since the projections 15 are provided at the intervals P at the end portion of the curved surface portion 13b over the distance of 0.3L or smaller from the opposite sides of the air outlet vent 3, a negative pressure area is generated in an area where the air velocity is slow, whereby an air flow is generated which flows towards the front surface portion (the lower surface side) 5a of the air direction deflector plate 5.

[0058] Thus, in particular, even when an air flow is weak with a slow air velocity, the air flow is allowed to flow along the front surface portion (the lower surface side) 5a of the air direction deflector plate 5, whereby the generation of condensation can be prevented which would otherwise be caused by the air flow flowing separate from the front surface portion (the lower surface side) 5a of the air direction deflector plate 5 as in a cooling operation.

[0059] Additionally, since force necessary to change the direction of the air flow W is proportional to flow velocity, a flow velocity Vw in this embodiment becomes in the order of $Vw = 1.0L$ to $3.0L$ for the width L of the air outlet vent 3 in Fig. 1.

[0060] Consequently, the projection 15 in this embodiment is given a substantially oval shape in which a major axis constitutes a flowing direction, and for the width L of the air outlet vent 3 shown in Fig. 1, a size of the projection 15 becomes such that a major axis L1 is 0.005L to 0.02L, a minor axis L2 is 0.001L to 0.01L, a height h is 0.001L to 0.01L, and an interval P at which the projections 15 are provided in a width direction of the air outlet vent 3 is 0.025L to 0.075L for the width L of the air outlet vent 3, whereby the flowing direction of the air flow is changed so that the air flow is allowed to flow along the front surface portion 5a of the air direction deflector plate 5 by increasing the air flow flowing in the vicinity of the curved surface portion 13b by generating a longitudinal vortex by the projection 15 without increasing excessively the resistance of the air flow by the projection 15.

[0061] In this embodiment, since a plurality of irregular portions 15a that are smaller than the plurality of projections are provided on the surface of the projection 15, the air flow is kept flowing along the projection 15 by a fine vortex generated in the vicinity of a wall surface of the projection 15, whereby a longitudinal vortex generated on an upstream side is prevented from being combined with a longitudinal vortex generated adjacent thereto.

[0062] Consequently, the longitudinal vortex generated at the projection 15 is ensured to arrive at the air direction deflector plate 5 while reducing the resistance by the projection 15, whereby an air flow is generated which flows towards the front surface portion (the lower surface side) 5a of the air direction deflector plate 5.

[0063] Thus, the air flow is allowed to flow along the air direction deflector plate 5, whereby the generation of condensation can be prevented which would otherwise be caused by the air flow flowing separate from the front surface portion (the lower surface side) 5a of the air direction deflector plate 5 during a cooling operation.

[0064] In this embodiment, since the projection 15 is given the substantially oval shape in which the major axis constitutes the flowing direction, compared with a circular shape, a smaller scaled vortex is generated when the air flow collides against the projection 15, and the air flow is guided by the major axis of the projection.

[0065] Consequently, in particular, even with a low air amount which hardly generates a longitudinal vortex, the longitudinal vortex generated at the projection 15 is ensured to be conveyed to the front surface portion (the lower surface side) 5a of the air direction deflector plate 5.

[0066] Thus, in particular, even when the air flow is weak at a slow air velocity with the air direction deflector plate 5 opening at a small angle as in a cooling operation, the air flow is allowed to flow along the air direction deflector plate, whereby the generation of condensation can be prevented which would otherwise be caused by the air flow flowing separate from the front surface portion (the lower surface side) of the air direction deflector plate as in a cooling operation.

[0067] In this embodiment, the intervals P at which the projections 15 are provided are made to be irregular intervals, whereby longitudinal vortexes generated by the projections 15 are made uneven, and a peak in a specific frequency band of noise generated at the air outlet vent 3 is suppressed, thereby making it possible to reduce the noise.

[0068] In this embodiment, the number of projections 15 is not particularly limited, provided that the intervals P are maintained, and longitudinal vortexes are generated at the projections 15 by an amount of air let out from the air outlet vent 3 to increase an air flow flowing in the vicinity of the curved surface portion 13b without increasing excessively a pressure loss of an air flow at each of the projections 15, and the number of air flows whose flowing directions are changed so as to flow along the front surface portion 5a of the air direction deflector plate 5 is changed.

Industrial Applicability

[0069] Thus, as has been described heretofore, the ceiling embedded air conditioner according to the present invention prevents the generation of condensation on a lower surface of the air direction deflector plate which would otherwise be caused by the air flow from the upstream of the internal air path flowing separate from a front edge portion of the air direction deflector plate and can be applied to an air conditioner, an air cleaner, a dryer, an air conditioner for a motor vehicle, and the like.

Reference Signs List

[0070]

- 2 casing
- 3 air outlet vent
- 4 air inlet vent
- 5 air direction deflector plate
- 6 decoration panel
- 13 inner air path
- 13a flat surface portion
- 13b curved surface portion
- 14 outer air path
- 15 projection
- 15a irregular portion

Claims

1. A ceiling embedded air conditioner comprising a casing (2) embedded in a ceiling, a decoration panel (6) provided at a bottom surface of the casing, an air inlet vent (4) provided in the decoration panel to let inside air in an inside of a room into an interior of the casing, an air outlet vent (3) configured to let the air into the interior of the casing from the air inlet vent out into the inside of the room, and an air direction deflector plate (5) provided at the air outlet vent, configured to rotate around a rotational shaft (5c) at an end of the air direction deflector plate to control a direction of the air,
- wherein the air outlet vent includes an inner air path (13) and an outer air path (14),
 wherein the inner air path is made up of a flat surface portion (13a) on an upstream side and a curved surface portion (13b) on a downstream side, and
 wherein a plurality of projections (15) are provided at an end portion of the curved surface portion so that an air flow colliding with the plurality of projections generates a longitudinal vortex and flows along a front surface portion (5a) which is provided to the air direction deflector plate at a lower surface side of the air direction deflector plate,
characterized in that
 a surface of each of the plurality of projections comprises a plurality of irregular portions (15a) that are smaller than the plurality of projections.
2. The ceiling embedded air conditioner according to claim 1,
 wherein each of the plurality of projections has an oval shape in which a major axis constitutes a flowing direction when the projection is seen from a normal direction thereof.

3. The ceiling embedded air conditioner according to claim 1 or 2,
 wherein the plurality of projections are provided at intervals (P) over a distance of 0.3L or smaller from opposite sides of the air outlet vent (3) for a width L of the air outlet vent (3).

Patentansprüche

1. Deckeneinbau-Klimaanlage, umfassend ein in eine Decke eingebettetes Gehäuse (2), eine an einer Bodenfläche des Gehäuses vorgesehene Dekorplatte (6), eine in der Dekorplatte vorgesehene Luft-einlassöffnung (4), um Innenluft in einem Inneren eines Raums in einen Innenraum des Gehäuses strömen zu lassen, eine Luftauslassöffnung (3), die dazu konfiguriert ist, die Luft aus der Lufteinlassöffnung in das Innere des Gehäuses und aus der Luftauslassöffnung in das Innere des Raums strömen zu lassen, und eine an der Luftauslassöffnung vorgesehene Luftrichtungs-Ablenkplatte (5), die dazu konfiguriert ist, sich um eine drehbare Welle (5c) an einem Ende der Luftrichtungs-Ablenkplatte zu drehen, um eine Richtung der Luft zu steuern,

wobei die Luftauslassöffnung einen inneren Luftpfad (13) und einen äußeren Luftpfad (14) umfasst,

wobei der innere Luftpfad aus einem flachen Oberflächenabschnitt (13a) auf einer stromaufwärts gelegenen Seite und einem gekrümmten Oberflächenabschnitt (13b) auf einer stromabwärts gelegenen Seite gebildet ist, und wobei mehrere Vorsprünge (15) an einem Endabschnitt des gekrümmten Oberflächenabschnitts vorgesehen sind, so dass ein Luftstrom, der mit den mehreren Vorsprüngen kollidiert, einen Längswirbel erzeugt und entlang eines vorderen Oberflächenabschnitts (5a) strömt, der an der Luftstrom-Ablenkplatte an einer unteren Oberflächenseite der Luftstrom-Ablenkplatte vorgesehen ist,

dadurch gekennzeichnet, dass

eine Oberfläche jedes der mehreren Vorsprünge mehrere unregelmäßige Abschnitte (15a) umfasst, die kleiner sind als die mehreren Vorsprünge.

2. Deckeneinbau-Klimaanlage nach Anspruch 1,
 wobei jeder der mehreren Vorsprünge eine ovale Form aufweist, bei der eine Hauptachse eine Fließrichtung darstellt, wenn der Vorsprung aus einer normalen Richtung davon betrachtet wird.
3. Deckeneinbau-Klimaanlage nach Anspruch 1 oder 2,
 wobei die mehreren Vorsprünge in Abständen (P)

über eine Strecke von 0,3 L oder weniger von gegenüberliegenden Seiten der Luftauslassöffnung (3) für eine Breite L der Luftauslassöffnung (3) vorgesehen sind.

5

Revendications

1. Climatiseur intégré au plafond comprenant un boîtier (2) intégré dans un plafond, un panneau de décoration (6) disposé au niveau d'une surface inférieure du boîtier, un événement d'entrée d'air (4) disposé dans le panneau de décoration destiné à laisser l'air intérieur à l'intérieur d'une pièce entrer dans l'intérieur du boîtier, un événement de sortie d'air (3) conçu pour laisser l'air dans l'intérieur du boîtier provenant de l'événement d'entrée d'air sortir dans l'intérieur de la pièce et une plaque déflectrice de sens d'air (5) disposée au niveau de l'événement de sortie d'air, conçue pour tourner autour d'un arbre rotatif (5c) au niveau d'une extrémité de la plaque déflectrice de sens d'air afin commander un sens de l'air,
 - l'événement de sortie d'air comprenant un trajet d'air interne (13) et un trajet d'air externe (14), le trajet d'air interne étant constitué d'une partie de surface plate (13a) sur un côté en amont et d'une partie de surface incurvée (13b) sur un côté en aval et une pluralité de saillies (15) étant disposées au niveau d'une partie d'extrémité de la partie de surface incurvée de telle sorte qu'un flux d'air entrant en collision avec la pluralité de saillies génère un tourbillon longitudinal et s'écoule le long d'une partie de surface avant (5a) qui est disposée sur la plaque déflectrice de sens d'air au niveau d'un côté de surface inférieure de la plaque déflectrice de sens d'air,

caractérisé en ce que

 une surface de chaque saillie parmi la pluralité de saillies comprend une pluralité de parties irrégulières (15a) qui sont plus petites que la pluralité de saillies.
2. Climatiseur intégré au plafond selon la revendication 1,

chaque saillie parmi la pluralité de saillies présentant une forme ovale dans laquelle un axe principal constitue une direction d'écoulement lorsque la saillie est vue depuis une direction perpendiculaire correspondante.
3. Climatiseur intégré au plafond selon la revendication 1 ou 2,

la pluralité de saillies étant disposées à des intervalles (P) sur une distance de 0,3 L ou moins à partir de côtés opposés de l'événement de sortie d'air (3) pour une largeur L de l'événement de sortie d'air (3).

FIG.1

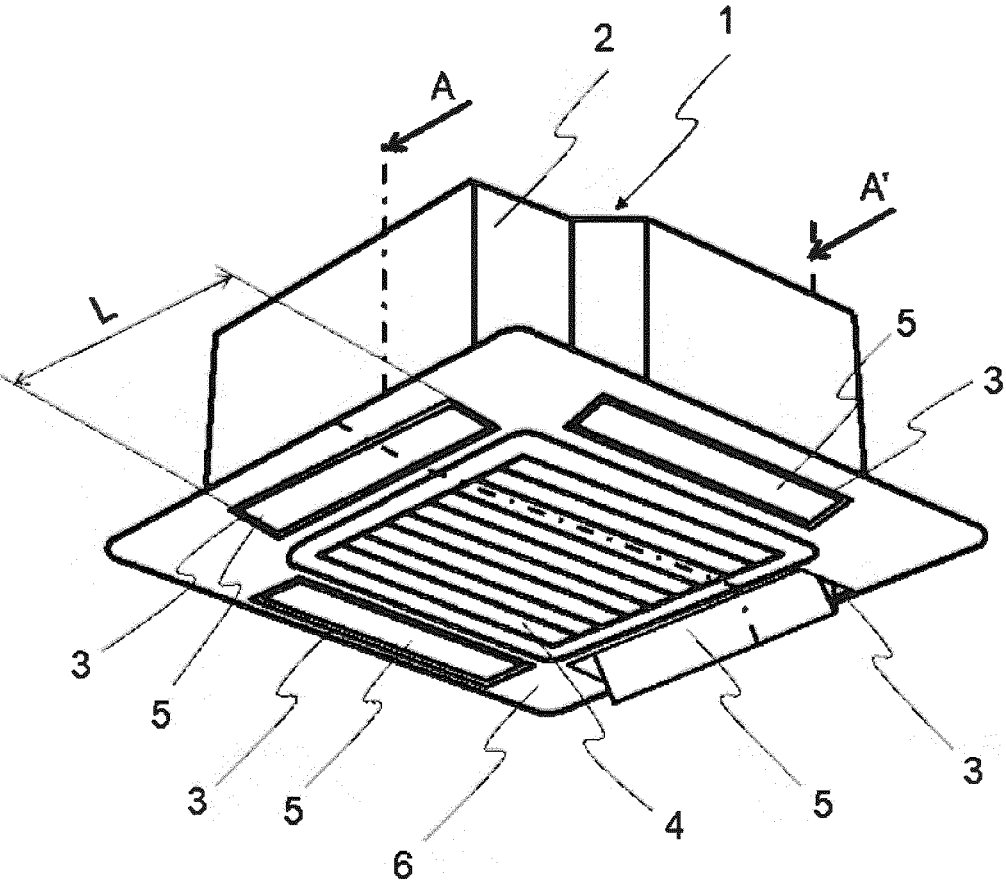

- 2: CASING
- 3: AIR OUTLET VENT
- 4: AIR INLET VENT
- 5: AIR DIRECTION DEFLECTOR PLATE
- 6: DECORATION PANEL

FIG.2

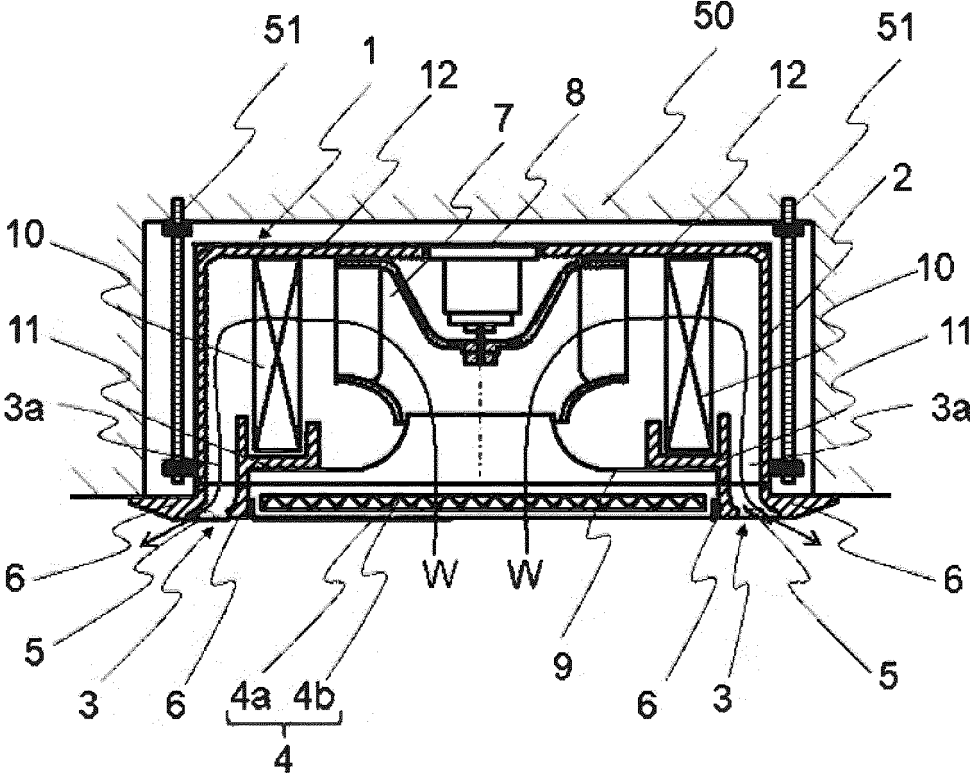

FIG. 3

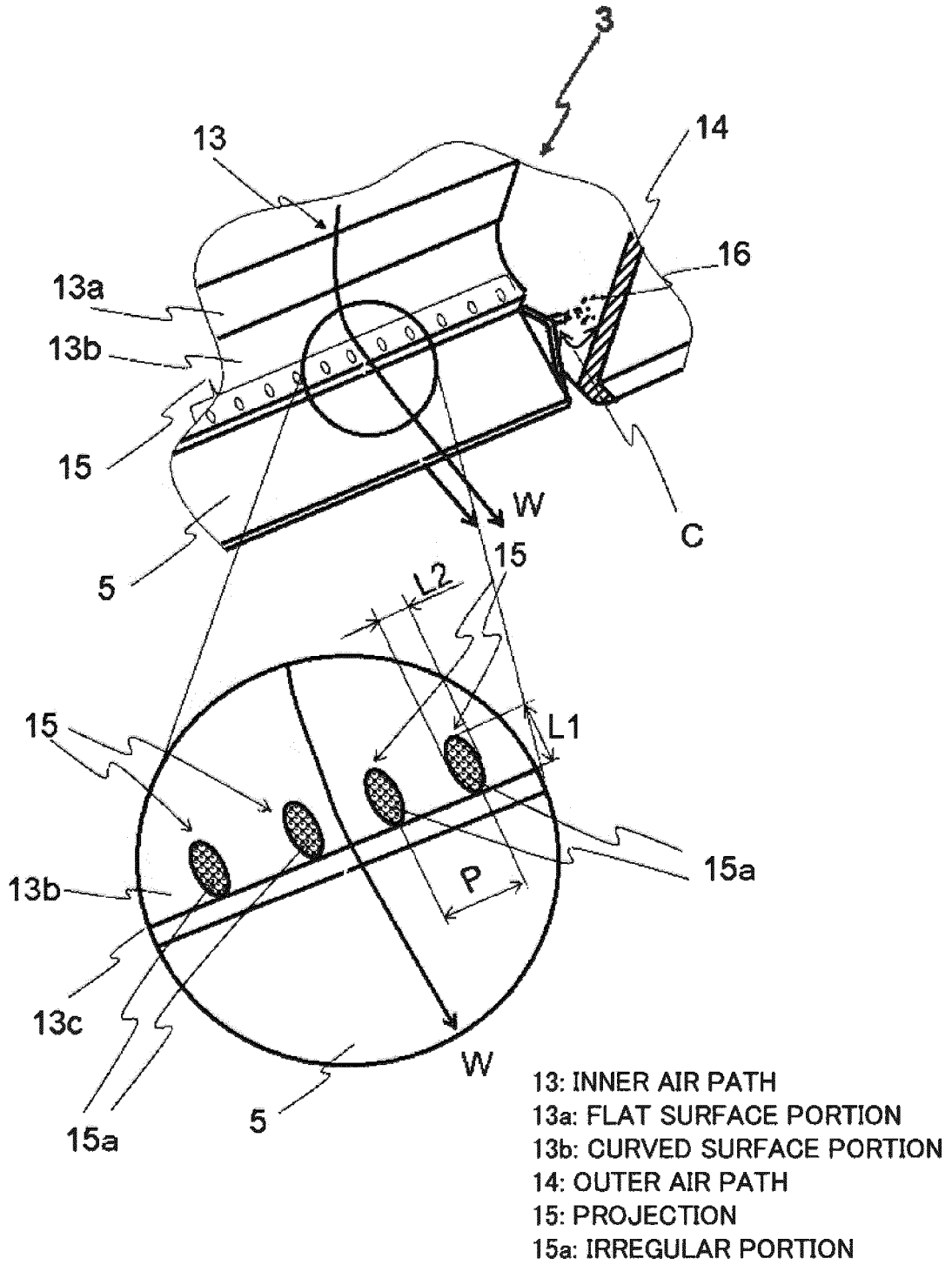

FIG.4

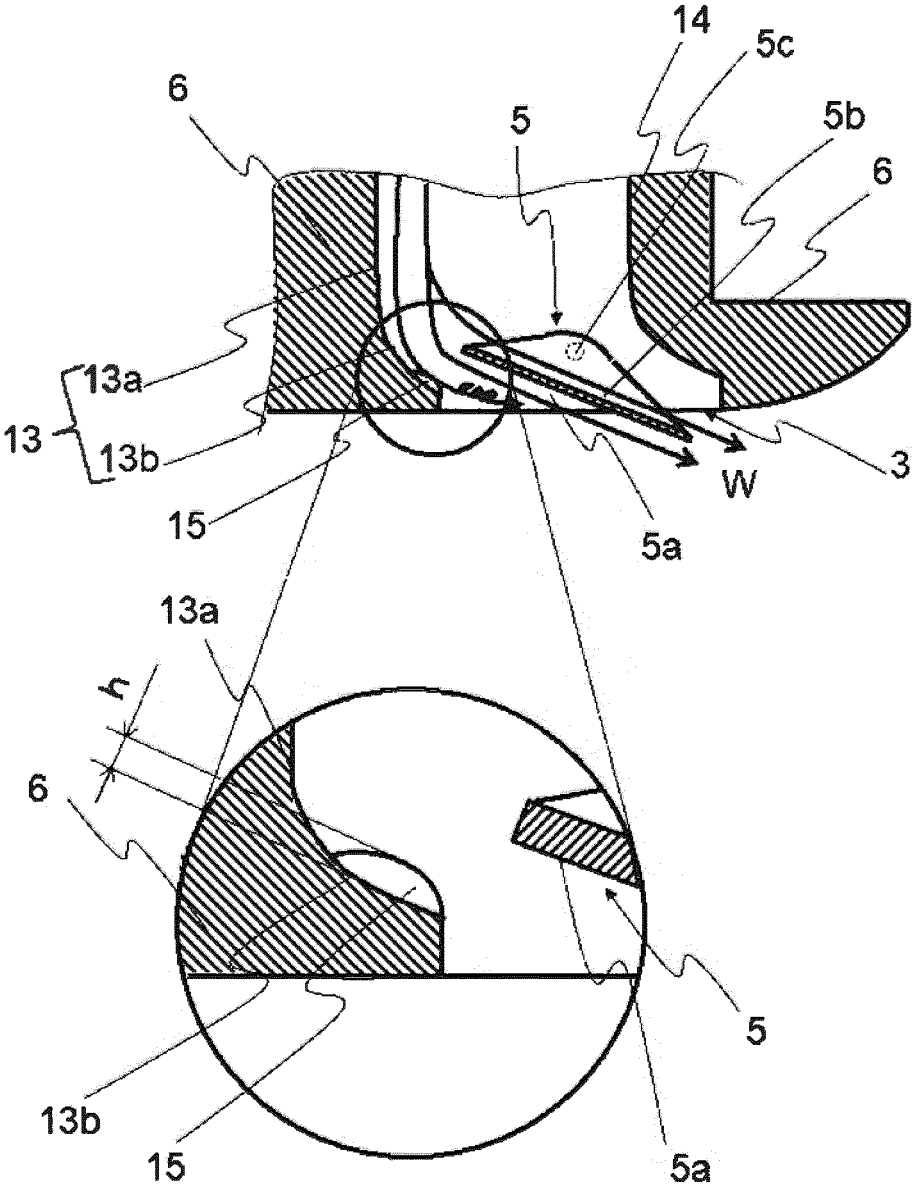

FIG. 5

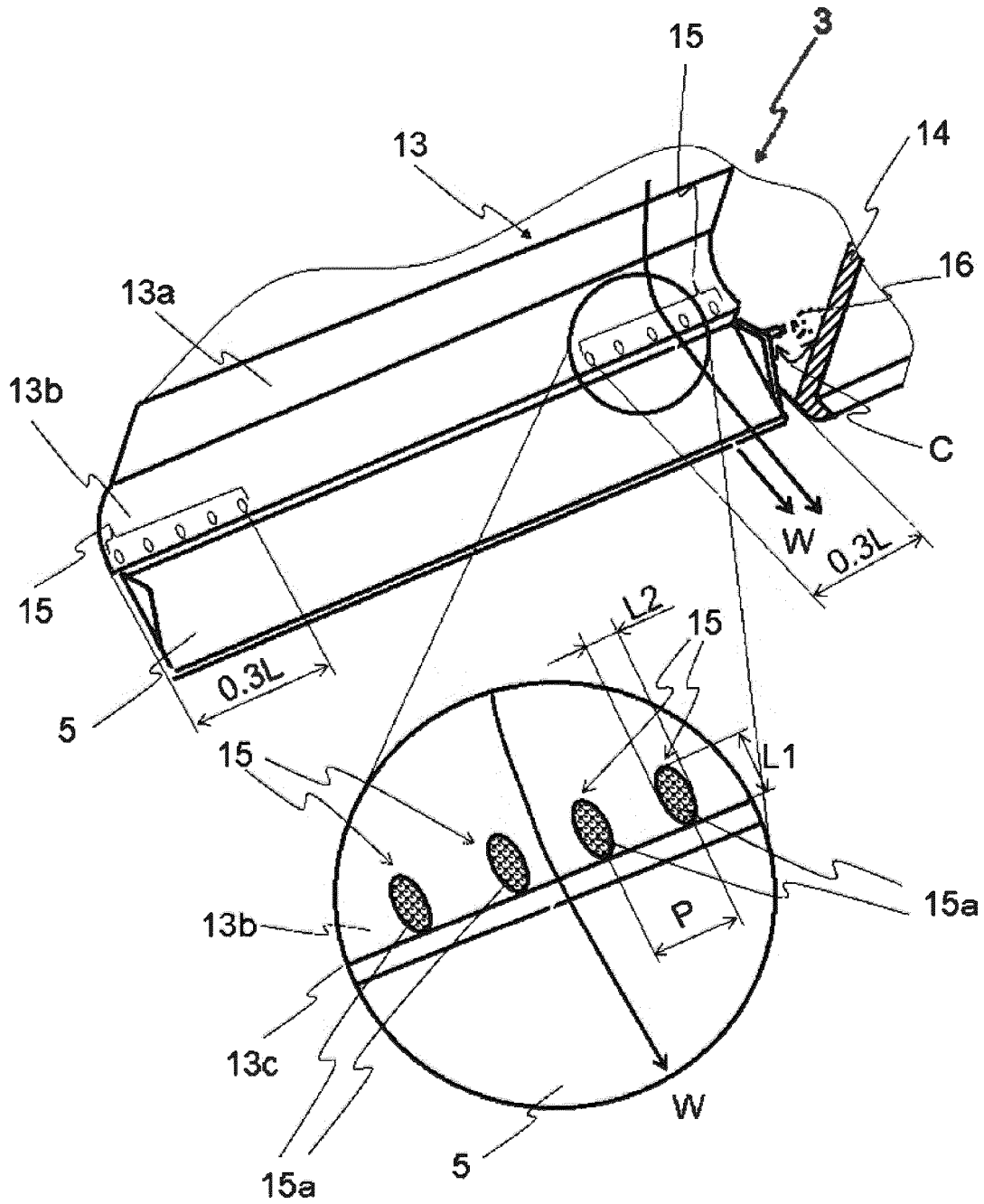

FIG. 6

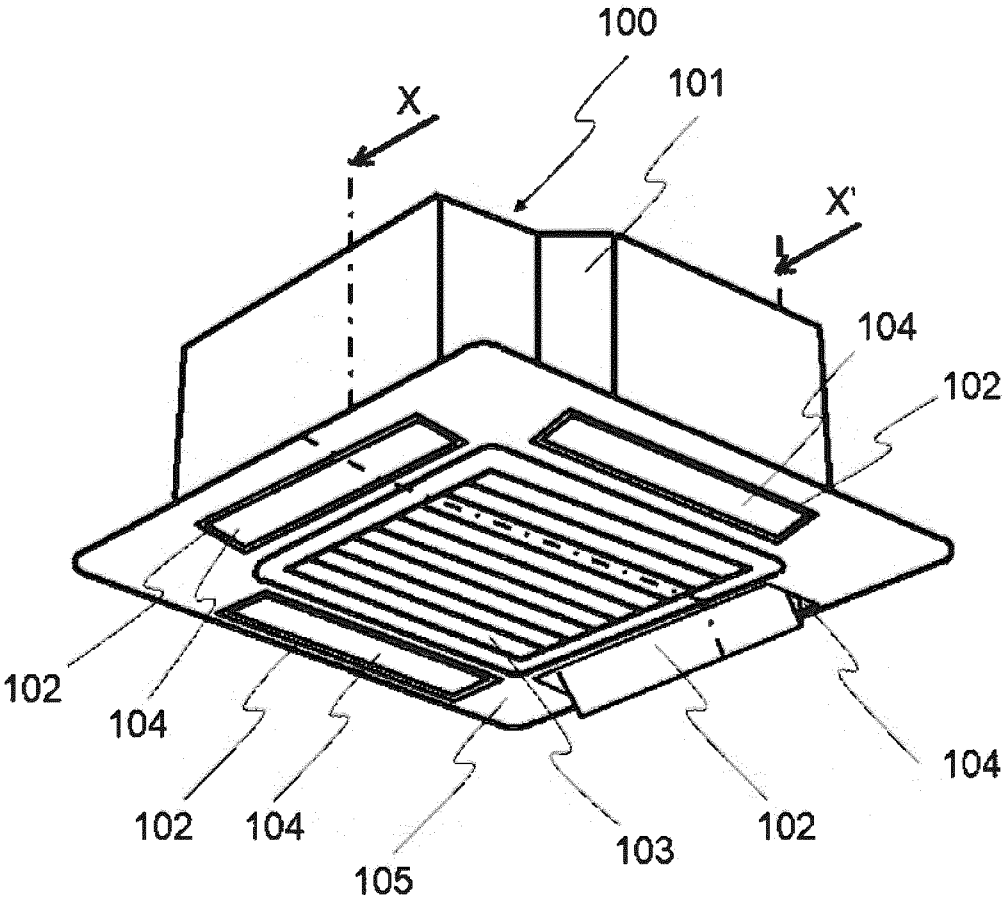
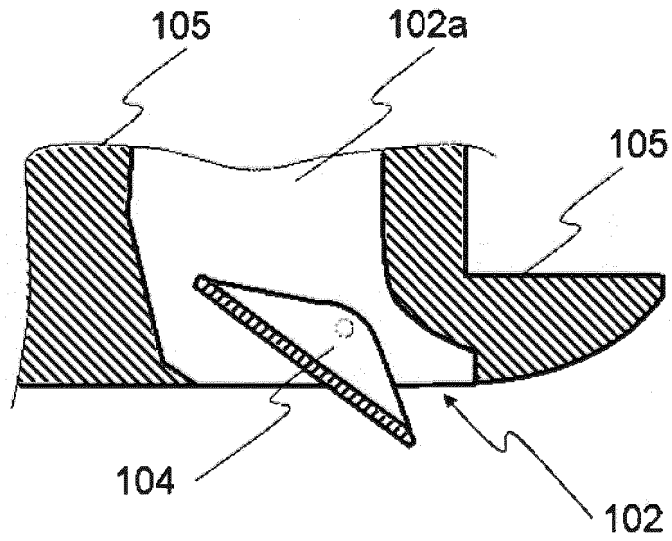
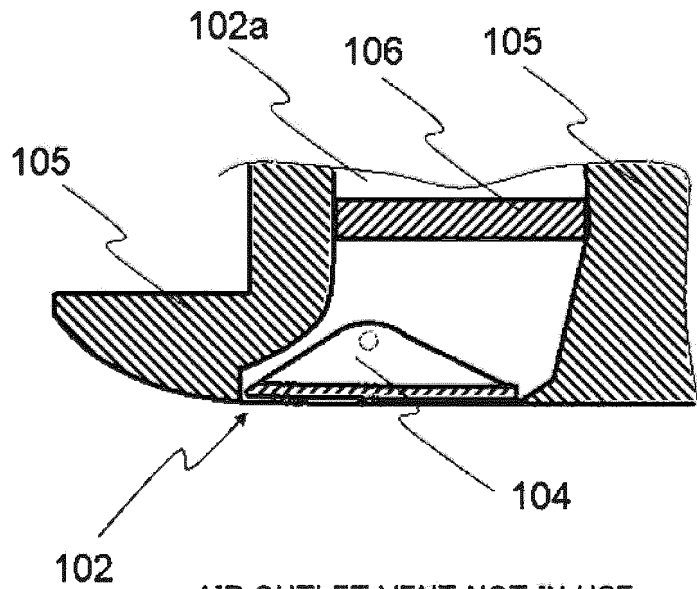

FIG.7A



AIR OUTLET VENT IN USE

FIG.7B



AIR OUTLET VENT NOT IN USE

FIG.8

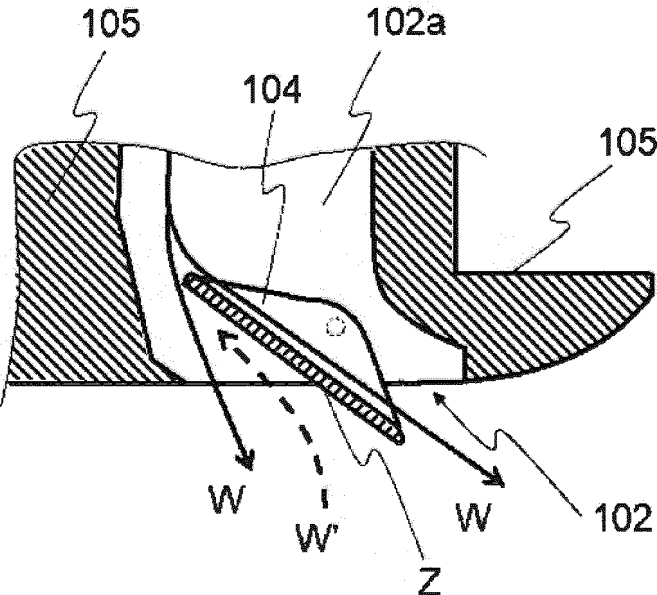

REFERENCES CITED IN THE DESCRIPTION

This list of references cited by the applicant is for the reader's convenience only. It does not form part of the European patent document. Even though great care has been taken in compiling the references, errors or omissions cannot be excluded and the EPO disclaims all liability in this regard.

Patent documents cited in the description

- JP 2000205642 A [0002]
- JP H0886504 B [0006]
- JP 2007024345 A [0007]