

(12) **United States Design Patent** (10) **Patent No.:** **US D776,507 S**  
**Faverio et al.** (45) **Date of Patent:** **\*\* Jan. 17, 2017**

(54) **ROTATABLE CRANK TOOL**

(71) Applicant: **EASY AWNING CRANK LLC**, Flat Rock, MI (US)

(72) Inventors: **Gregory George Faverio**, Flat Rock, MI (US); **Gino Faverio**, Canton, MI (US); **Paul Edward Faverio, Jr.**, Gibraltar, MI (US)

(73) Assignee: **Easy Awning Crank LLC**, Flat Rock, MI (US)

(\*\*) Term: **14 Years**

(21) Appl. No.: **29/519,835**

(22) Filed: **Mar. 9, 2015**

(51) **LOC (10) Cl.** ..... **08-05**

(52) **U.S. Cl.**  
 USPC ..... **D8/70**

(58) **Field of Classification Search**  
 USPC ..... D8/14, 44, 59, 60, 70, 90, 98, 314, 349, D8/358, 359, 360, 380, 382, 499; D12/96, 106, D12/217, 223, 400; D24/147; D32/35, 40, 46, D32/49; 29/264, 227, 240.5; 81/441, 53.2; 172/13, 18, 19, 22, 25; 408/225, 227, 211  
 CPC .. B23B 51/0045; F16B 13/002; F16B 13/065; F16B 21/10; F16B 2013/007; Y10T 408/5583; B66D 3/006; B66D 3/18; B66D 3/26; B66D 3/02; B66D 3/14  
 See application file for complete search history.

(56) **References Cited**  
 U.S. PATENT DOCUMENTS

1,345,027 A 6/1920 Rippe  
 4,209,903 A \* 7/1980 Owens ..... A01G 3/06 294/50.7  
 4,311,288 A \* 1/1982 Galland ..... B60P 7/0846 242/399

D334,577 S \* 4/1993 Wheat ..... D15/139  
 D345,288 S \* 3/1994 Hubal ..... D12/106  
 D379,578 S \* 6/1997 Daniels ..... D8/70  
 D400,411 S \* 11/1998 Ambrose ..... D8/14  
 D419,414 S \* 1/2000 Pellak ..... D15/138  
 D424,901 S \* 5/2000 Landry ..... D8/107  
 6,102,637 A \* 8/2000 Mocci ..... B60P 7/083 410/100  
 D440,476 S \* 4/2001 Del Gaone ..... D8/14  
 6,398,147 B1 \* 6/2002 Fredrickson ..... B65H 54/553 242/390.8  
 6,398,470 B1 \* 6/2002 Mosley ..... B60P 7/0853 410/100  
 D475,589 S \* 6/2003 Wilkinson ..... D8/29  
 (Continued)

*Primary Examiner* — Darlington Ly  
 (74) *Attorney, Agent, or Firm* — Carrier Blackman & Associates, P.C.; Joseph P. Carrier; William D. Blackman

(57) **CLAIM**  
 The ornamental design for a rotatable crank tool, as shown and described.

**DESCRIPTION**

FIG. 1 is a right side elevational view of a rotatable crank tool showing our new design;  
 FIG. 2 is a front elevational view thereof;  
 FIG. 3 is a rear elevational view thereof;  
 FIG. 4 is a left side elevational view thereof;  
 FIG. 5 is a top plan view thereof;  
 FIG. 6 is a bottom plan view thereof;  
 FIG. 7 is perspective view thereof; and,  
 FIG. 8 is an enlargement view thereof, of which the area being enlarged is the bottom end of the tool as indicated by the broken line reference circle in FIG. 7.  
 In FIG. 7, the broken line showing of the drill is provided for the purpose of illustrating environmental structure and forms no part of the claimed design. Furthermore, in FIGS. 7 and 8, the broken line circle is provided as a graphical symbol to indicate the area of enlargement and also forms no part of the claimed design.

**1 Claim, 3 Drawing Sheets**

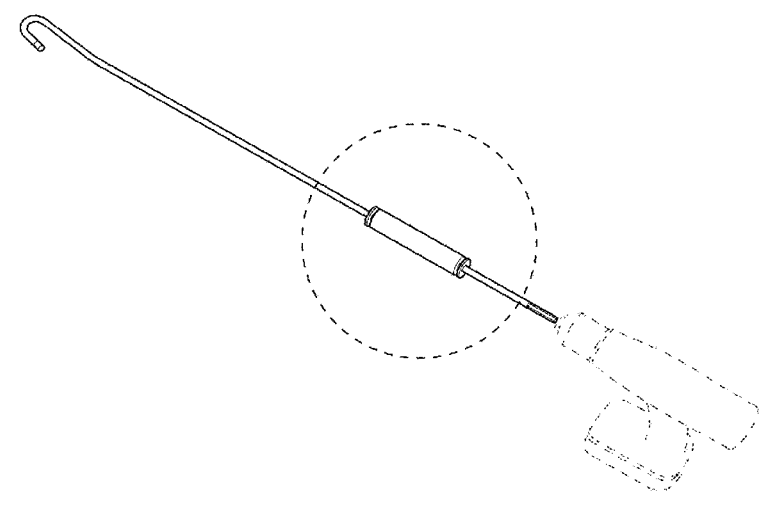

(56)

**References Cited**

U.S. PATENT DOCUMENTS

D477,763 S \* 7/2003 Hebert ..... D8/70  
6,705,597 B1 \* 3/2004 Reilly ..... B60P 7/0846  
254/223  
6,863,430 B2 \* 3/2005 Berube ..... B01F 13/002  
366/129  
D526,173 S \* 8/2006 Hudson ..... D8/44  
7,141,074 B2 \* 11/2006 Fanger ..... A61B 17/1617  
606/80  
D576,007 S \* 9/2008 Murdock ..... D8/70  
D663,185 S \* 7/2012 Denning ..... D8/70  
D696,703 S \* 12/2013 Tsai ..... D15/138  
D703,814 S \* 4/2014 Bolia ..... D24/133  
D704,335 S \* 5/2014 Bolia ..... D24/133  
D750,946 S \* 3/2016 Hardman ..... D8/44  
D751,880 S \* 3/2016 Howell ..... D8/70

\* cited by examiner

**Fig. 1**

**Fig. 2**

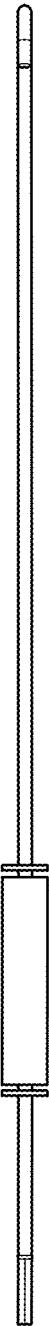

**Fig. 3**

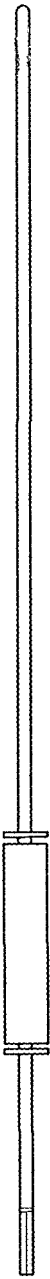

**Fig. 4**

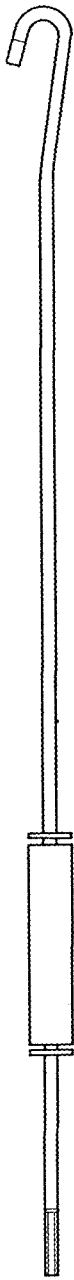
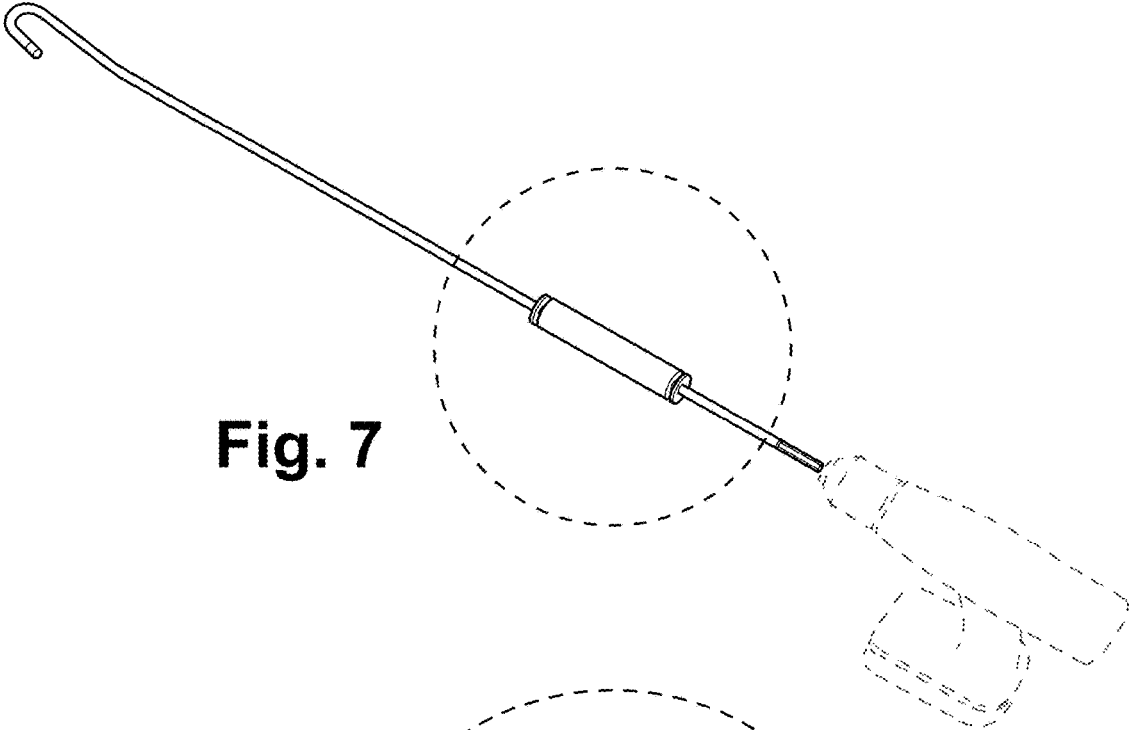

**Fig. 5**

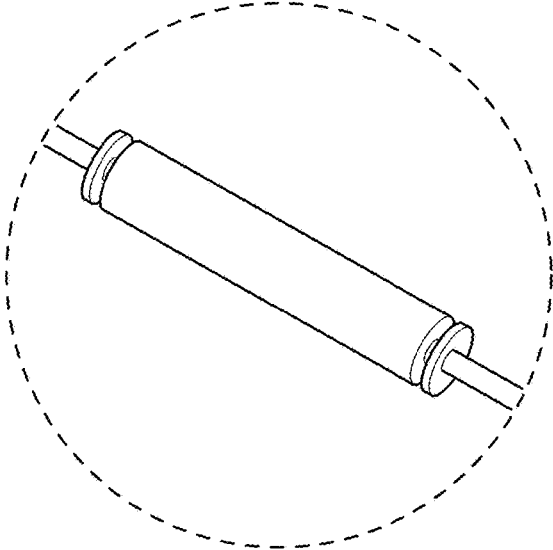

**Fig. 6**





**Fig. 7**



**Fig. 8**