



(11) **EP 2 434 844 B1**

(12) **EUROPEAN PATENT SPECIFICATION**

(45) Date of publication and mention of the grant of the patent:
03.08.2016 Bulletin 2016/31

(51) Int Cl.:
H05B 41/282^(2006.01)

(21) Application number: **11181655.9**

(22) Date of filing: **16.09.2011**

(54) **Lighting device, illumination fixture, and illumination system**

Beleuchtungsanordnung, Beleuchtungsbefestigung und Beleuchtungssystem

Dispositif d'éclairage, appareil d'éclairage et système d'éclairage

(84) Designated Contracting States:
AL AT BE BG CH CY CZ DE DK EE ES FI FR GB GR HR HU IE IS IT LI LT LU LV MC MK MT NL NO PL PT RO RS SE SI SK SM TR

(30) Priority: **27.09.2010 JP 2010216200**

(43) Date of publication of application:
28.03.2012 Bulletin 2012/13

(73) Proprietor: **Panasonic Intellectual Property Management Co., Ltd.**
Osaka 540-6207 (JP)

(72) Inventors:
• **Hamamoto, Katunobu**
Neyagawa, Osaka (JP)
• **Himeda, Masato**
Shikama-ku,
Himeji, Hyogo 652-8039 (JP)

(74) Representative: **Rüger, Rudolf**
Webergasse 3
73728 Esslingen (DE)

(56) References cited:
US-A1- 2010 013 393 US-B1- 6 181 086

EP 2 434 844 B1

Note: Within nine months of the publication of the mention of the grant of the European patent in the European Patent Bulletin, any person may give notice to the European Patent Office of opposition to that patent, in accordance with the Implementing Regulations. Notice of opposition shall not be deemed to have been filed until the opposition fee has been paid. (Art. 99(1) European Patent Convention).

Description

[Field of the Invention]

5 **[0001]** The present invention relates to a lighting device which is capable of measuring input power, an illumination fixture, and an illumination system.

[Background Art]

10 **[0002]** There have been proposed power source devices in which power supplied from an external power source is converted appropriately and supplied to a load, while input power (or power consumption) is measured to present externally (e.g. refer to patent literatures 1 and 2). Measurement results of input power, which are obtained from these power source devices, are presented to a user of the power source devices and an administrator of a facility in which the power source devices are installed, and can be utilized for reduction of wasted power consumption (i.e. power saving).

15 **[0003]** As a method to measure input power, it is known in general to use a current transformer, but if the current transformer which is difficult to miniaturize and relatively expensive is used in each of power source devices, the power source devices will also be enlarged and result in being expensive.

20 **[0004]** Meanwhile, there is also proposed a lighting device which is configured to enable measurement of input power without using the current transformer. The lighting device has a power conversion part which includes a switching element and appropriately converts DC power inputted from a DC power source part so as to supply to a light source load, a current detection part for detecting a current flowing in the switching element, and a calculation part for obtaining input power by using a detection value of the current detection part.

25 **[0005]** Here, the current detection part includes a detection resistor connected in series to the switching element, and outputs, as a detection value, a value which is made higher as a current flowing in the switching element and the detection resistor is larger. The calculation part calculates, by using a detection value V_s of the current detection part and constants a and β , input power (or power consumption) W_{in} from an expression $W_{in} = a \times V_s + \beta$.

30 **[0006]** In this configuration, the current detection part can include the resistance element which is connected in series to the switching element, thereby making it possible to realize a relatively small lighting device (or power source device) inexpensively.

[Conventional Technique Literature]

[Patent Literature]

35 **[0007]**

[Patent literature 1] JP S64-13695 T

[Patent literature 2] JP 3168842

40 [Disclosure of the Invention]

[Problems to be solved by the Invention]

45 **[0008]** Fluorescent lamps which are representatively used as a light source load are known to have a tendency such that, owing to a temperature characteristic thereof, impedance (= lamp voltage / lamp current) is changed depending on an ambient temperature with an increased lamp current and decreased lamp power under high-temperature or low-temperature environments. In a light source using a light emitting diode to which attention has been paid in recent years, owing to a temperature characteristic thereof, impedance is also changed depending on an ambient temperature. Therefore, in a lighting device which allow lighting of the light source loads, it is devised to improve controllability by a feedback control or other controls so that a current and a voltage flowing in the loads correspond to a predetermined characteristic relative to impedance fluctuations of the light sources.

50 For example US 2010/0013393 A1 discloses a discharge lamp lighting device which detects a direct current superimposed on an alternating current, both currents flowing through the discharge lamp. The device modifies the dimming signal depending on a threshold comparison of the detected direct current with predetermined thresholds. Accordingly the dimming signal is modified depending on impedance changes of the discharge lamp.

55 **[0009]** However, the input power W_{in} calculated by the expression $W_{in} = a \times V_s + \beta$ as stated above fails to correspond to a load characteristic such as reduction of a signal integrated value in response to an increase of input power caused by an ambient temperature change, therefore, a relatively large error may possibly occur in relation to actual input power.

That is, no problem will arise as long as a light source load has a constant ambient temperature, but if there is a change in the ambient temperature, a value of the input power W_{in} obtained from the above arithmetic expression may not be sufficiently accurate.

5 [0010] The present invention was achieved in view of the above circumstances and has an object to provide a lighting device, an illumination fixture and an illumination system in which input power can be measured without using a current transformer and input power can be obtained with sufficient accuracy even if there is a change in the ambient temperature of a light source load.

10 [Means adapted to solve the Problems]

[0011] A lighting device according to the present invention is provided with a power conversion part which includes a switching element and adjusts power supplied to a light source load by receiving DC power as an input and in response to an operation to turn on/off the switching element, a control part for controlling the power conversion part to operate by receiving a power setting value which determines the size of power supplied to the light source load, a current detection part for detecting a current flowing in the switching element, a power estimation part for estimating input power by using a detection value of the current detection part, and a presentation part for presenting an estimation result of the power estimation part, wherein the power estimation part obtains input power by using a power setting value and a current detection value which corresponds to an output of the current detection part, and through correction of a fluctuation of a current detection value caused by a change in the ambient temperature of a light source load.

20 [0012] In the lighting device, the power estimation part normalizes the power setting value by using, as a maximum power value, a power setting value obtained when power is supplied to the light source load at the maximum, and obtains input power by using a power adjustment value corresponding to a difference between the power setting value and the current detection value.

25 [0013] In the lighting device, the power estimation part obtains a value corresponding to input power by subtracting a power adjustment value from a value obtained by multiplying, to a ratio of a power setting value relative to a power maximum value, a coefficient which is set in advance so as to be larger than a power adjustment value.

[0014] An illumination fixture according to the present invention includes a fixture main body including the above lighting device, and a light source load held by the fixture main body.

30 [0015] An illumination system according to the present invention includes a plurality of the illumination fixtures and also having a read device for reading estimation results of the power estimation part by receiving a notification signal transmitted from the presentation part.

[Effect of the Invention]

35 [0016] The present invention has advantages such that input power can be measured without using a current transformer and input power can be obtained with sufficient accuracy even if there is a change in an ambient temperature of a light source load.

[Brief Description of the Drawings]

40 [0017]

[Fig. 1] Fig. 1 is a schematic circuit diagram showing a configuration of a lighting device according to a first embodiment.

45 [Fig. 2] Fig. 2 is a schematic circuit diagram showing a main part of Fig. 1.

[Fig. 3] Fig. 3 is a time chart showing how a frequency generation part of Fig. 1 is operated.

[Fig. 4] Fig. 4 is an explanatory diagram showing a relationship between input power and a current detection value in Fig. 1.

50 [Fig. 5] Fig. 5 is a model diagram showing a relationship between the input power and the current detection value in Fig. 1.

[Fig. 6] Fig. 6 is an explanatory diagram showing a relationship between the input power and the current adjustment value in Fig. 1.

[Fig. 7] Fig. 7 is an explanatory diagram showing a relationship between input power and a calculated value when a is 4.5 as shown in Fig. 7(a), a is 5 as shown in Fig. 7(b), and α is 6 as shown in Fig. 7(c).

55 [Fig. 8] Fig. 8 is an explanatory diagram showing a relationship between lamp power and a calculated value when a is 5 in Fig. 7.

[Fig. 9] Fig. 9 is an explanatory diagram showing a relationship between input power and a calculated value obtained when a is 8 in Fig. 7.

[Fig. 10] Fig. 10 is a schematic circuit diagram showing a configuration of a lighting device according to a second embodiment.

[Fig. 11] Fig. 11 is a perspective view showing an illumination fixture using the lighting device of Fig. 10.

5 [Best Mode for Carrying Out the Invention]

(First embodiment)

10 **[0018]** A lighting device 1 of a present embodiment has, as shown in Fig. 1, a rectifier 2 connected to an AC power source 100, a DC power source circuit 3, a power conversion circuit 4, a load circuit 5, a control circuit 6, a frequency calculation part 7, and an output setting part 8. Note that the lighting device 1 does not include the AC power source 100 and a discharge lamp 11 shown in Fig. 1 as a component.

15 **[0019]** The DC power source circuit (or DC power source part) 3 which includes a smoothing capacitor (not shown) is connected to an output of the rectifier 2 so as to smooth a full-wave rectified voltage outputted from the rectifier 2. Accordingly, when the AC power source 100 is turned on, a smoothed DC voltage is outputted from the DC power source circuit 3, and the DC voltage is applied to the power conversion circuit (or power conversion part) 4 in a rear stage. Note that the DC power source circuit 3 is not limited to a specific concrete configuration as long as it is configured to have at least a smoothing capacitor.

20 **[0020]** The power conversion circuit 4 has a pair of switching elements 41 and 42 connected in series between output ends of the DC power source circuit 3. Each of the switching elements 41 and 42 is made of MOSFET. The pair of the switching elements 41 and 42 is turned on/off alternately in response to a driving signal outputted from the control circuit 6 so as to supply high frequency power to the load circuit 5.

25 **[0021]** The load circuit 5 is connected in parallel with the switching element 42, having a series circuit including a DC cut capacitor 51, a resonance inductor 52, and a resonance capacitor 53. The discharge lamp 11 serving as a load (or light source load) of the lighting device 1 is connected in parallel with the resonance capacitor 53.

30 **[0022]** Moreover, the lighting device 1 is further provided with a preheating circuit 9 for preheating filaments of the discharge lamp 11, and the preheating circuit 9 is also connected in parallel with the switching element 42. The preheating circuit 9 includes a preheating transformer 92 whose primary winding is connected to an output of the power conversion circuit 4 via a capacitor 91, and a secondary winding of the preheating transformer 92 is used to supply a preheating current to each filament of the discharge lamp 11 via a capacitor 93 and a capacitor 94.

35 **[0023]** Furthermore, in the example of Fig. 1, a control power source circuit 10 for supplying a control power source voltage V_{cc1} to the control circuit 6 is also connected in parallel with the switching element 42. The control power source circuit 10 generates a control power source voltage between both ends of a capacitor 101 in response to a switching operation of the power conversion circuit 4, and clamps a voltage to reach a desired level by a zener voltage of a zener diode 102. However, a concrete circuit configuration of the control power source circuit 10 is not limited to the configuration of Fig. 1 as long as it is configured to enable generation of a control power source in response to a switching operation of the power conversion circuit 4.

40 **[0024]** The control circuit 6 includes mainly a drive part 61, a reference power source generation part 62, and a frequency generation part 63. The reference power source generation part 62 receives the control power source voltage V_{cc1} inputted to the control circuit 6, and generates a power source voltage V_{cc2} which is outputted to the frequency generation part 63 as well as the frequency calculation part 7 and the output setting part 8 which are described later. The reference power source generation part 62 is not limited to a specific concrete configuration as long as it is configured to enable generation of a constant voltage (e.g. power source voltage V_{cc2}) by using a zener diode and a band gap.

45 **[0025]** The frequency generation part 63 determines a frequency of a driving signal outputted to the switching elements 41 and 42 of the power conversion circuit 4. The frequency generation part 63 has, as shown in Fig. 2, an operational amplifier 631 for configuring a constant voltage buffer part, an output transistor 630, a current mirror 632, and a comparator 633. The current mirror 632 determines, in accordance with an output of the operational amplifier 631, by using a current flowing in a load part (which is a resistor 634 or the like here) through the output transistor 630 as a source, a value of a current flowing in a capacitor 635. The comparator 633 controls a charging/discharging current flowing in the capacitor 635 by comparing a voltage between both ends of the capacitor 635 and a predetermined threshold value.

50 **[0026]** If a voltage between both ends of the capacitor 635 is lower than a predetermined threshold value V_{ref2} , a current determined by an output voltage V_{ref1} of the constant voltage buffer part and a resistance value of the resistor 634 is made to flow in the resistor 634. Owing to this current, the capacitor 635 is charged by a constant current via the current mirror 632 which has a predetermined mirror ratio. In contrast, if a voltage between both ends of the capacitor 635 reaches the predetermined threshold value V_{ref2} , a "+" input of the comparator 633 is switched to a threshold value V_{ref3} by a transfer gate part 636. Furthermore, a switching element 637 is turned off by an output of the comparator 633 to start charging the capacitor 635 with a constant current.

[0027] That is, in accordance with switching an output of the comparator 633 between "H" and "L" as shown in Fig.

3(b), a voltage between both ends of the capacitor 635 shows a waveform of a triangular wave shape as shown in Fig. 3(a) along with switching of charging and discharging.

[0028] Here, if a current flowing in the output transistor 630 in response to an output of the operational amplifier 631 is larger, a charging/discharging current value of the capacitor 635 is made larger with larger inclination of a triangular wave shown in Fig. 3(a), thereby resulting in a high frequency in a triangular wave. The frequency generation part 63 thus controls a frequency of a triangular wave by comparing a voltage between both ends of the capacitor 635 and a predetermined threshold value and using an oscillator which uses the comparator 633 for controlling a charging/discharging current flowing in the capacitor 635.

[0029] A voltage outputted from the comparator 633 is inputted to a counter part 638 and a dead time part 639 in a rear stage. Although a concrete circuit is not shown in Fig. 2, the counter part 638 is configured to invert an output thereof at a falling edge of an input signal so as to generate a counter signal of a rectangular wave as shown in Fig. 3(c). A counter signal generated in the counter part 638 is inputted to the dead time part 639, and two driving signals each of which has a quiescent period so as not to turn on the switching elements 41 and 42 simultaneously are generated in the dead time part 639.

[0030] The dead time part 639 generates a first driving signal with "L" maintained during a period t_d from rising of a counter signal as shown in Fig. 3(d) by a combination of a delay factor such as a capacitor and a logic element. The dead time part 639 outputs the first driving signal to a first drive part 611 which configures the drive part 61. The first drive part 611 drives, in response to the first driving signal, the switching element 42 via a resistor 43 (refer to Fig. 1).

[0031] The dead time part 639 also generates, by using a signal obtained by inverting a counter signal of Fig. 3(c), a second driving signal with "L" maintained during the period t_d from rising of the inverted signal so as to output to a second drive part 612 which configures the drive part 61. The second drive part 612 drives the switching element 41 via a resistor 44 (refer to Fig. 1) in response to the second driving signal. That is, the period t_d is a quiescent period of the driving signals.

[0032] Next, the frequency calculation part 7 will be explained referring to Fig. 2. The frequency calculation part 7 configures an integrator by mainly having an operational amplifier 71 and a capacitor 72 which is connected between an inverted input end and an output end of the operational amplifier 71. A voltage outputted from the operational amplifier 71 is called a power adjustment value hereinafter.

[0033] A pulse signal is outputted from a power setting part 81 which configures the output setting part 8 to be described later, and a DC voltage obtained by converting the pulse signal into a direct current in a smoothing part which includes resistors 73 and 74 and a capacitor 75 is inputted to a non-inverted input end of the operational amplifier 71 as a power setting value. The pulse signal outputted from the power setting part 81 has a duty ratio corresponding to a lighting control rate which is determined inside the power setting part 81 or determined based on a lighting control signal inputted from an externally operable lighting control signal generation device.

[0034] Meanwhile, to the inverted input end of the operational amplifier 71, a voltage between both ends of the detection resistor (or current detection part) 45 connected in series to the switching element 42 arranged on a low voltage side of the power conversion circuit 4 is inputted via a resistor 76. The detection resistor 45 is inserted in a space between a low voltage side (or source) of the switching element 42 and an output end on a negative side of the DC power source circuit 3 so as to detect a current flowing in the switching element 42. Therefore, to the inverted input end of the operational amplifier 71, a current detection value corresponding to a current flowing in the switching element 42 (or an integrated value of a voltage between both ends of the detection resistor 45) is inputted.

[0035] An output end of the operational amplifier 71 is connected to the output transistor 630 connected to an output end of the operational amplifier 631 which configures the frequency generation part 63 via a diode 77 and a resistor 78.

[0036] Owing to the above configuration, the operational amplifier 71 has an output voltage (or power adjustment value) which is reduced if a current detection value inputted to the inverted input end thereof is larger than a power setting value inputted to the non-inverted input end thereof. If an output voltage (or power adjustment value) of the operational amplifier 71 is reduced, a current drawn out to the output end of the operational amplifier 71 via the diode 77 and the resistor 78 is increased. Therefore, a current flowing in the output transistor 630 which configures the frequency generation part 63 is increased and a frequency of a driving signal supplied to the power conversion circuit 4 becomes high, accompanied by a decrease of power consumed in the load circuit 5 owing to a resonance action of the load circuit 5.

[0037] In contrast, if an integrated value of a current detection value is small relative to a power setting value, an output voltage of the operational amplifier 71 (i.e. power adjustment value) is raised and a frequency of a driving signal supplied to the power conversion circuit 4 becomes low, accompanied by increased power consumed in the load circuit 5.

[0038] The frequency calculation part 7 thus controls power consumption of the load circuit 5 so as to achieve a desired value by changing an operating frequency (or switching frequency) of the power conversion circuit in accordance with an increase and decrease of a power adjustment value outputted from the operational amplifier 71. In summary, the control circuit 6 and the frequency calculation part 7 configure a control part which controls the power conversion circuit 4 to operate by receiving a power setting value for determining a size of power (or lamp power) supplied to the discharge lamp 11.

[0039] Explained next will be the output setting part 8. The output setting part 8 includes, as shown in Fig. 1, the power

EP 2 434 844 B1

setting part 81 for generating a pulse signal with a duty ratio corresponding to a lighting control rate, a maximum power setting part 82 for storing a maximum power value, and a power calculation part 83 for executing a predetermined calculation.

[0040] The maximum power setting part 82 stores in advance a maximum power value corresponding to a pulse signal which is outputted from the power setting part 81 when a value of power consumed in the load circuit 5 is at the maximum.

[0041] The power calculation part 83 executes a predetermined calculation by receiving an output of the power setting part 81 (i.e. power setting value), an output of the maximum power setting part 82 (i.e. maximum power value), and a power adjustment value inputted from the above frequency calculation part 7, and estimates input power of the lighting device 1. That is, the power calculation part 83 functions as a power estimation part for estimating input power by using a detection value of the detection resistor 45 serving as a current detection part.

[0042] Explained below will be an operation to obtain input power of the lighting device 1 by the power calculation part 83 referring to tables 1 and 2 and Figs.4 to 6.

[0043] The tables 1 and 2 show, for each ambient temperature of the discharge lamp 11, input power (or power consumption), lamp power, current detection values, power adjustment values, and calculation results of the power calculation part 83. Here, the tables 1 and 2 show each value obtained when, using two of fluorescent lamps (FHF63 type) in the discharge lamp 11, the discharge lamp 11 is subjected to dimmed lighting by a resonance action with 200 V set for an input of the lighting device 1, and the discharge lamp 11 has an ambient temperature changed in a range from -10°C to 60°C. The current detection value used here is a numerical value obtained by equalizing a voltage between both ends of the detection resistor 45 shown in Fig. 1 and a fine value including a measurement error. The power adjustment value corresponds to a voltage outputted from the operational amplifier 71 which configures the frequency calculation part 7.

[0044] The table 1 corresponds to a lighting control rate of 100% (or full lighting), wherein a pulse signal with a duty ratio of 100% is outputted from the output setting part 8 and converted into a power setting value with a direct current of 330 mV in the smoothing part. The table 2 corresponds to dimmed lighting with a lighting control rate of about 25%, wherein a pulse signal with a duty ratio of 50% is outputted from the output setting part 8 and converted into a current setting value with a direct current of 165 mV in the smoothing part. Furthermore, in the maximum power setting part 82, a power setting value with a direct current of 330 mV corresponding to a pulse signal with a duty ratio of 100%, which is outputted from the output setting part 8 when a dimming control of 100% is performed, is set as a maximum power value in advance.

[Table 1]

Ambient temperature [°C]	Input power [W]	Lamp power [W]	Current detection value [mV]	Power adjustment value [V]	Calculation result
-10	132.3	111.6	28.4	3.10	1.90
0	135.5	116.4	29.2	3.04	1.96
10	139.7	122.8	24.8	2.98	2.02
25	139.9	123.2	26.8	2.98	2.02
35	136.1	119.7	29.0	3.02	1.98
45	131.5	114.3	27.1	3.09	1.91
60	125.6	106.4	27.9	3.17	1.83

[Table 2]

Ambient temperature [°C]	Input power [W]	Lamp power [W]	Current detection value [mV]	Power adjustment value [V]	Calculation result
-10	45.8	33.0	7.2	1.89	0.61
0	44.2	31.4	9.1	1.92	0.58
10	42.1	28.7	7.3	1.95	0.55
25	40.6	27.1	9.0	1.98	0.53
35	40.6	27.7	10.3	1.98	0.52

EP 2 434 844 B1

(continued)

Ambient temperature [°C]	Input power [W]	Lamp power [W]	Current detection value [mV]	Power adjustment value [V]	Calculation result
45	40.9	28.6	8.2	1.97	0.53
60	40.3	29.1	8.9	1.98	0.52

[0045] Fig. 4 shows a relationship between input power and a current detection value in the cases of the table 1 (in the lighting control rate of 100%) and the table 2 (in the lighting control rate of about 25%). In Fig. 4, measurement data of the table 1 is shown by a rhombus mark and measurement data of the table 2 is shown by a square mark.

[0046] Here, Fig. 5 shows a simplified relationship between input power and a current detection value.

[0047] If the discharge lamp 11 has a constant ambient temperature, a change in the lighting control rate is accompanied by a signal integrated value which is increased in a slightly curved manner as input power is increased (i.e. positive characteristic). Shown by "X" in Fig. 5 is a relationship between input power and a current detection value in the case of changing the lighting control rate from about 20% to 100% under an environment with an ambient temperature of 25°C.

[0048] In contrast, in a state with a lighting control rate of 100%, if the discharge lamp 11 has an ambient temperature changed in a range from 10°C to 75°C, input power is increased/decreased depending on a temperature characteristic of the discharge lamp 11, while a current detection value tends to have a negative characteristic to decrease in accordance with increased input power as shown in a region indicated by "Y" in Fig. 5. Even if the discharge lamp 11 has an ambient temperature changed in a range from -10°C to 75°C in a state with a lighting control rate of about 20%, a current detection value tends to have a negative characteristic to decrease in accordance with increased input power as shown in a region indicated by "Z" in Fig. 5.

[0049] Note that, in Fig. 5, the reason why a relationship between input power and a current detection value in the vicinity of the lighting control rates of 100% and 20% is shown by the elliptic regions "Y" and "Z" is because of frequently observed measurement errors resulting from the detection resistor 45 whose resistance value is relatively low and a detection current value which is a fine value. The reason why the detection resistor 45 is set to a low resistance is to avoid enlargement of the detection resistor 45 and to further prevent, in turning on the switching element 42, a gate driving voltage from being insufficient as a result of high source potential.

[0050] As a main cause of having a relationship between a current detection value and input power with a tendency as indicated by "Y" and "Z" in Fig. 5, a balance change between an active current and a reactive current by a resonance action is considered due to an impedance change in the discharge lamp 11 owing to the temperature characteristic.

[0051] More specifically, under high-temperature and/or low-temperature environments, a lump current is increased with decreased lamp power or decreased lamp voltage, but owing to the resonance capacitor 53 connected in parallel with the discharge lamp 11, reduction of a lamp voltage is followed by a decreased reactive current. In other words, impedance of the discharge lamp 11 is reduced by the temperature characteristic, and a reactive current flowing in a parallel circuit made of the discharge lamp 11 and the resonance capacitor 53 is decreased. In contrast, when a lamp current is increased, an active current is increased.

[0052] As a result, a combined current made of an active current and a reactive current is easily increased, which causes an increased circuit component loss. In contrast, lamp power is reduced as stated above and a current detection value therefore tends to be reduced as input power is increased.

[0053] From the explanation above, calculation of the input power W_{in} by using the expression $W_{in} = a \times V_s + \beta$ as explained in the background art column is possible as long as the discharge lamp 11 has a constant ambient temperature, but it is impossible to correspond to a reduction of a current detection value relative to increased input power resulting from an ambient temperature change. Accordingly, if there is a change in the ambient temperature of the discharge lamp 11, an obtained value of the input power W_{in} may not be sufficiently accurate.

[0054] In addition, various embodiments are considered for an illumination fixture in which the lighting device 1 is arranged in a fixture main body, and even if an illumination fixture is operated, for example, under a condition with an ambient temperature of 25°C, an ambient temperature of the discharge lamp 11 will vary depending on an embodiment of the illumination fixture. Therefore, even if an illumination fixture has a constant ambient temperature, a value of input power may not be sufficiently accurate depending on an embodiment of the illumination fixture.

[0055] Furthermore, it is considered to provide a configuration such that a plurality of constants a and β used in the above arithmetic expression is set in advance so as to appropriately select constants a and β corresponding to a temperature detected by a temperature detection part (not shown), and such a configuration can be realized relatively easily by using a microcomputer. However, as is obvious from the explanation above, since a temperature detection part has no meaning unless it is arranged in the vicinity of the discharge lamp 11, it is necessary to provide a configuration of installing a temperature detection part in a fixture main body of an illumination fixture, therefore, the illumination fixture

becomes expensive. It is further necessary to use a microcomputer with a relatively large storage capacity in order to store a plurality of constants α and β in advance.

[0056] In contrast, in the lighting device 1 of the present embodiment, the power calculation part 83 obtains input power by using a power setting value and a current detection value corresponding to an output of the detection resistor 45, through correction of a fluctuation of a current detection value caused by a change in the ambient temperature of the discharge lamp 11. Furthermore, in the present embodiment, the power calculation part 83 normalizes a power setting value by using a maximum power value which is a power setting value obtained when power is supplied to the discharge lamp 11 at the maximum, and obtains input power by using a power adjustment value corresponding to a difference between a power setting value and a current detection value.

[0057] To be more specific, the power calculation part 83 executes a first calculation which is expressed by an expression $a \times W_s/W_{max}$ by using a power setting value W_s , a coefficient a , and a maximum power value W_{max} set in the maximum power setting part 82. The power calculation part 83 further executes a second calculation for subtracting a power adjustment value V_{fb} from the first calculation result. That is, the power calculation part 83 carries out a calculation expressed by an expression $(a \times W_s/W_{max}) - V_{fb}$ and a result thereof is outputted as a calculated value (or calculation result).

[0058] Fig. 6 shows a relationship between input power and a power adjustment value for each of the table 1 (in the lighting control rate of 100%) and the table 2 (in the lighting control rate of about 25%). In Fig. 6, measurement data of the table 1 is shown by a rhombus mark and measurement data of the table 2 is shown by a square mark. In the present embodiment, the output voltage V_{ref1} of the operational amplifier 631 which configures the frequency generation part 63 is set to 3.5 V, and the operational amplifier 71 is set to have an output voltage (or power adjustment value) which is always lower than the output voltage V_{ref1} (i.e. 3.5 V). A relationship between input power and a power adjustment value as shown in Fig. 6 tends to have a similar negative characteristic as explained in Fig. 5.

[0059] Here, the tables 1 and 2 show, in the calculation result column, calculation results (or calculated values) obtained when the power calculation part 83 carries out the above calculations (i.e. first and second calculations) with the coefficient a which is 5.

[0060] Figs. 7a to 7c also show a relationship between a calculated value and input power obtained when the power calculation part 83 carries out the above calculations (i.e. first and second calculations) with the coefficient a which is 4.5 or 5.6.

[0061] When the coefficient a is 4.5, as shown in Fig. 7(a), calculated values tend to be lower than a straight line (referred to as a "reference line" hereinafter) by which 0[W] and maximum power (139.9[W]) is connected. In contrast, when the coefficient a is 6, as shown in Fig. 7(c), calculated values tend to be higher than the reference line. Coincidence between the reference line and calculated values with relatively high accuracy is seen when the coefficient a is around 5, and a relationship between input power and calculated values obtained when the coefficient a is 5 is as shown in Fig. 7(b).

[0062] Here, a value of the coefficient α is selected out of values which are higher than the output voltage V_{ref1} (which is 3.5 V here) of the operational amplifier 631 for configuring the frequency generation part 63, in accordance with power calculation accuracy set as a target, the type of a load to be used, and a circuit constant of the frequency calculation part 7. Since an output voltage (or power adjustment value) of the operational amplifier 71 is set to be lower than the output voltage V_{ref1} of the operational amplifier 631, the coefficient α is set to be a value which is larger than at least a power adjustment value.

[0063] A calculated value of the power calculation part 83 has a relationship substantially proportional to not only input power of the lighting device 1 but also lamp power as shown in Fig. 8. Fig. 8 shows a relationship between calculated values and lamp power obtained when the power calculation part 83 carried out the above calculations with the coefficient a which is 5.

[0064] Calculation results of the power calculation part 83 obtained as stated above (or input power and/or lamp power estimated from calculation results) are presented by a presentation part (not shown) of the lighting device 1. The presentation part presents calculation results to a user of the lighting device 1 or the like by a method such as display and audio. User or the like can therefore utilize presented calculation results for reduction of wasted power consumption (or power saving).

[0065] According to the lighting device 1 of the present embodiment as explained above, the power calculation part 83 obtains input power by using a current detection value corresponding to an output of the detection resistor 45, whereby input power can be measured without using a current transformer. The power calculation part 83 further corrects, by using a power setting value and a current detection value, a fluctuation of a current detection value caused by a change in the ambient temperature of the discharge lamp 11, whereby a calculation result which is substantially proportional to input power and/or lamp power can be obtained with high accuracy. In summary, the power calculation part 83 can obtain input power by using not only a current detection value but also a power setting value which determines the size of power supplied to the discharge lamp 11, from a relationship between a current detection value and a power setting value, through correction of a fluctuation of a current detection value caused by an ambient temperature change.

[0066] In addition, the power calculation part 83 normalizes a power setting value by using a maximum power value which is a power setting value obtained when power is supplied to the discharge lamp 11 at the maximum, and obtains input power by using a power adjustment value corresponding to a difference between a power setting value and a current detection value. Therefore, the power calculation part 83 can obtain, by using the relatively simple calculations, input power relatively accurately.

[0067] That is, the power calculation part 83 is required to carry out, by using the maximum power value W_{max} , the power setting value W_s , and the power adjustment value V_{fb} , a calculation which is expressed by the expression $(a \times W_s/W_{max}) - V_{fb}$, so that a calculation result which is substantially proportional to input power can be obtained by the simple calculations using only four basic operations. Accordingly, the power calculation part 83 can be realized by a combination of simple logic elements or the like without using a microcomputer.

[0068] Note that a calculation made by the power calculation part 83 may be any calculations as long as using the maximum power value W_{max} , the power setting value W_s , and the power adjustment value V_{fb} , and is not limited to the above calculations. That is, even if the power calculation part 83 carries out, for example, a calculation expressed by an expression $(W_s/W_{max}) - (\beta \times V_{fb})$ by using a coefficient β , similar to the above example, a calculation result which is substantially proportional to input power and/or lamp power can be obviously obtained.

[0069] Fig. 9 further shows a relationship between input power and a calculation result (or calculated value) obtained by using the above expression $(a \times W_s/W_{max}) - V_{fb}$ with the coefficient a which is 8. As long as it is allowed to have a calculated value which is not 0 when input power is 0 and calculation accuracy is slightly low, even in the case of Fig. 9, a substantially linear relationship can be seen between input power and calculated values. Therefore, in such a case, a calculation such as $(a \times W_s/W_{max}) - V_{fb} - A$ is carried out by using a predetermined value A , similar to the above example, a calculation result which is substantially proportional to input power and/or lamp power can be obtained.

[0070] In addition, though the present embodiment shows an example in which the power calculation part 83 functions as a power estimation part, the power estimation part may have any configurations as long as input power can be accurately estimated by using a detection value of the detection resistor 45 serving as a current detection part, and it is not essential to carry out a calculation. For example, the power estimation part may be configured to have a table in advance by which input power is approximated from a relationship between a power setting value and a current detection value, and estimate input power by applying a power setting value and a current detection value to the table.

[0071] Note that the present embodiment exemplified, by using the discharge lamp as a light source load, the lighting device 1 which carries out high-frequency lighting with an inverter operation, but is not limited to the configuration. That is, the lighting device 1 may also be configured so that a calculation result which is substantially proportional to input power and/or lamp power can be obtained by carrying out a frequency control and/or a pulse width control using an operational amplifier on the basis of a detection value of a current flowing in a switching element, and using a calculation similar to that of the present embodiment. For example, the lighting device 1 may be configured to use a light emitting diode for illumination as a light source load and allow lighting of the light source load by a step-down chopper operation.

(Second embodiment)

[0072] The lighting device 1 according to the present embodiment is provided with a notification part 12 arranged as a presentation part as shown in Fig. 10 in order to receive calculation results of the power calculation part 83 of the output setting part 8 and notify the calculation results to an external device. Configurations similar to those of the first embodiment are referred to below with the same reference numbers as those of the first embodiment and explanation thereof is omitted appropriately.

[0073] In the present embodiment, the power calculation part 83 executes a following calculation by using a coefficient a , a coefficient γ , a maximum power value W_{max} , a power setting value W_s , and a power adjustment value V_{fb} :

$$\{(a \times W_s/W_{max}) - V_{fb} + W_s\} \times \gamma$$

[0074] Following tables 3 and 4 show, for each ambient temperature of the discharge lamp 11, input power, lamp power, current detection value, power adjustment value, calculation result of the power calculation part 83, and calculation result error relative to input power. These tables 3 and 4 show each value obtained when, using two fluorescent lamps (FHF63 type) for the discharge lamp 11, the discharge lamp 11 is subjected to dimmed lighting by a resonance action with 200 V set for an input of the lighting device 1 and the discharge lamp 11 has an ambient temperature changed in a range from -10°C to 60°C. Calculation results shown here are obtained when the power calculation part 83 carries out a calculation with the coefficient a which is 4.9 and the coefficient γ which is 62.

[0075] The table 3 corresponds to a lighting control rate of 100% (i.e. full lighting), wherein a pulse signal with a duty ratio of 100% is outputted from the output setting part 8 and converted into a power setting value with a direct current

EP 2 434 844 B1

of 330 mV in the smoothing part. The table 4 corresponds to dimmed lighting with a lighting control rate of about 25%, wherein a pulse signal with a duty ratio of 50% is outputted from the output setting part 8 and converted into a current setting value with a direct current of 165 mV in the smoothing part. Furthermore, in the maximum power setting part 82, a power setting value with a direct current of 330 mV corresponding to a pulse signal with a duty ratio of 100%, which is outputted from the output setting part 8 when a dimming control of 100% is performed, is set in advance as a maximum power value.

[Table 3]

Ambient temperature [°C]	Input power [W]	Lamp power [W]	Current detection value [mV]	Power adjustment value [V]	Calculation result	Calculation error [%]
-10	132.3	111.6	28.4	3.10	132.2	0.0
0	135.5	116.4	29.2	3.04	135.6	-0.1
10	139.7	122.8	24.8	2.98	139.5	+0.2
25	139.9	123.2	26.8	2.98	139.6	+0.2
35	136.1	119.7	29.0	3.02	136.5	-0.3
45	131.5	114.3	27.1	3.09	132.7	-0.9
60	125.6	106.4	27.9	3.17	127.4	-1.2

[Table 4]

Ambient temperature [°C]	Input power [W]	Lamp power [W]	Current detection value [mV]	Power adjustment value [V]	Calculation result	Calculation error [%]
-10	45.8	33.0	7.2	1.89	44.7	+2.5
0	44.2	31.4	9.1	1.92	43.2	+2.4
10	42.1	28.7	7.3	1.95	40.9	+2.8
25	40.6	27.1	9.0	1.98	39.4	+3.1
35	40.6	27.7	10.3	1.98	39.6	+2.6
45	40.9	28.6	8.2	1.97	39.8	+2.8
60	40.3	29.1	8.9	1.98	39.4	+2.4

[0076] It is understood from the table 3 that calculation results are obtained with an error which is less than about 1% relative to input power in the case of lighting with a lighting control rate of 100%, and from the table 4 that calculation results are obtained with an error which is less than about 3% relative to input power in the case of lighting with a lighting control rate of about 25%.

[0077] Furthermore, because the lighting device 1 according to the present embodiment is provided with the notification part 12 serving as a presentation part, calculation results of the power calculation part 83 can be notified externally by the notification part 12. The notification part 12 notifies calculation results through communications to a read device arranged outside the lighting device 1.

[0078] Other configurations and functions are similar to those of the first embodiment.

[0079] The lighting device 1 according to each of the above embodiments is, as shown in Fig. 11, incorporated in a fixture main body 130 of a ceiling installation type and configures an illumination fixture 13 along with a light source load (i.e. discharge lamp 11) which is held by the fixture main body 130. Electrical connection between the lighting device 1 and the discharge lamp 11 is realized via socket parts 131 and 132 arranged in the fixture main body 130.

[0080] In an illumination system provided with a plurality of such illumination fixtures 13, a system administrator and/or a user uses, as a read device, a remote control receiver and a personal computer or other devices which are capable of numerically displaying a communication signal outputted from the notification part 12 in each of the plurality of the illumination fixtures 13. That is, a system administrator and/or a user can see the amount of power usage with relatively high accuracy by receiving notification signals from the notification parts 12 using one read device. Such an illumination

system can also be included inexpensively in comparison with the case of using a current transformer.

[Description of Reference Numerals]

5	[0081]
	1 Lighting device
	3 DC power source circuit (DC power source part)
	4 Power conversion circuit (Power conversion part)
10	6 Control circuit
	7 Frequency calculation part
	11 Discharge lamp (light source load)
	12 Notification part (presentation part)
	13 Illumination fixture
15	42 Switching element
	45 Detection resistor (current detection part)
	81 Power setting part
	83 Power calculation part (power estimation part)
20	130 Fixture main body

Claims

1. A lighting device comprising:

a power conversion part (4) including a switching element (42) and receiving DC power as an input in order to adjust power supplied to a light source load (11) by an operation to turn on/off the switching element (42);
 a control part (6, 7) receiving a power setting value (W_s) adapted to determine size of power supplied to the light source load (11) and to control the power conversion part (4);
 a current detection part (45) adapted to detect a current flowing in the switching element (42) and to obtain a corresponding current detection value;
 a power estimation part (83) adapted to estimate the input power (W_{in}) of the lighting device;

characterized by

a presentation part adapted to present the estimated input power (W_{in}) of the lighting device to a user or to notify the estimated input power (W_{in}) of the lighting device to an external device,
 the power estimation part (83) estimates the input power (W_{in}) by using the power setting value (W_s) and the current detection value, thereby providing correction of the input power (W_{in}) estimation for fluctuations of the current detection value caused by a change in the ambient temperature of the light source load by means of the following calculation:

- calculating a ratio by dividing the power setting value (W_s) by a stored maximum power value (W_{max}), which corresponds to the power setting value obtained in response to maximum power supplied to the light source load (11), and multiplying said ratio with a preset coefficient (α) to obtain a first value,
 - subtracting a power adjustment value (V_{fb}) from said first value obtained by multiplying the preset coefficient (α) with said ratio of the power setting value (W_s) relative to the maximum power value (W_{max}), wherein the power adjustment value (V_{fb}) corresponds to a difference between the power setting value (W_s) and the current detection value and wherein the value of the coefficient (α) is larger than the power adjustment value (V_{fb}).

2. An illumination fixture (13) having: a fixture main body (130) comprising the lighting device according to claim 1, and the light source load (11) held by the fixture main body (130).

3. An illumination system having a plurality of the illumination fixtures (13) according to claim 2, and a read device for reading the estimation result of the power estimation part (83) by receiving a communication signal transmitted from the presentation part.

Patentansprüche

1. Beleuchtungseinrichtung aufweisend:

5 einen Leistungswandlerteil (4) aufweisend ein Schaltelement (42) und eine Gleichspannungsleistung als Einganggröße erhaltend, um die zu einer Lichtquellenlast (11) gelieferte Leistung mittels eines Betriebs des Einschaltens/Ausschaltens des Schaltelements (42) einzustellen;
 einen Steuerteil (6, 7), der einen Leistungsvorgabewert (W_s) empfängt, der zur Bestimmung einer Größe der Leistung, die an die Lichtquellenlast (11) geliefert wird und zur Steuerung des Leistungswandlerteils (4) eingerichtet ist;
 10 einen Stromerfassungsteil (45), der dazu eingerichtet ist, einen in das Schaltelement (42) fließenden Strom zu erfassen und einen entsprechenden Stromerfassungswert zu erhalten;
 einen Leistungsschätzungsteil (83), der dazu eingerichtet ist, die Eingangsleistung (W_{in}) der Beleuchtungseinrichtung zu schätzen;
 15 **gekennzeichnet durch**
 einen Darstellungsteil, der dazu eingerichtet ist, die geschätzte Eingangsleistung (W_{in}) der Beleuchtungseinrichtung einem Benutzer darzustellen oder die geschätzte Eingangsleistung (W_{in}) der Beleuchtungseinrichtung einer externen Einrichtung mitzuteilen,
 wobei der Leistungsschätzungsteil (83) die Eingangsleistung (W_{in}) **durch** die Verwendung des Leistungsvorgabewerts (W_s) und dem Stromerfassungswert schätzt, wobei eine Korrektur der Schätzung der Eingangsleistung (W_{in}) von Fluktuationen des Stromerfassungswerts bereitgestellt wird, die **durch** eine Änderung in der Umgebungstemperatur der Lichtquellenlast verursacht wird, mittels der folgenden Berechnung:

25 - Berechnen eines Verhältnisses **durch** Teilen des Leistungsvorgabewertes (W_s) **durch** einen gespeicherten maximalen Leistungswert (W_{max}), der dem Leistungsvorgabewert entspricht, der als Antwort zum Bereitstellen der maximalen Leistung für die Lichtquellenlast (11) erhalten wird, und Multiplizieren dieses Verhältnisses mit einem vorgegebenen Koeffizienten (α), um einen ersten Wert zu erhalten,
 - Abziehen eines Leistungseinstellwertes (V_{fb}) von dem ersten Wert, der **durch** die Multiplikation des vorgegebenen Koeffizienten (α) mit dem Verhältnis des Leistungsvorgabewertes (W_s) zum maximalen Leistungswert (W_{max}) erhalten wurde, wobei der Leistungseinstellwert (V_{fb}) einer Differenz zwischen dem Leistungsvorgabewert (W_s) und dem Stromerfassungswert entspricht und wobei der Wert des Koeffizienten (α) größer ist als der Leistungseinstellwert (V_{fb}).

35 **2.** Beleuchtungshalterung (13) aufweisend: einen Halterungshauptkörper (130) aufweisend die Beleuchtungseinrichtung nach Anspruch 1 und die Lichtquellenlast (11), die durch den Halterungshauptkörper (130) gehalten ist.

3. Beleuchtungssystem aufweisend einer Mehrzahl von Beleuchtungshalterungen (13) nach Anspruch 2 und eine Leseeinrichtung zum Lesen des Schätzungsergebnisses des Leistungsschätzungsteils (83) durch Empfang eines Kommunikationssignals, das von dem Darstellungsteil übermittelt wurde.

Revendications

1. Dispositif d'éclairage comprenant :

45 une partie de conversion d'énergie (4) comportant un élément de commutation (42) et recevant de l'énergie à courant continu en entrée afin d'ajuster la puissance fournie à une charge de source de lumière (11) par une opération pour rendre passant/bloqué l'élément de commutation (42) ;
 une partie de commande (6, 7) recevant une valeur de réglage de puissance (W_s) adaptée pour déterminer l'amplitude de la puissance fournie à la charge de source de lumière (11) et pour commander la partie de conversion d'énergie (4) ;
 50 une partie de détection de courant (45) adaptée pour détecter un courant circulant dans l'élément de commutation (42) et pour obtenir une valeur de détection de courant correspondante ;
 une partie d'estimation de puissance (83) adaptée pour estimer la puissance d'entrée (W_{in}) du dispositif d'éclairage ;
 55

caractérisé par :

EP 2 434 844 B1

une partie de présentation adaptée pour présenter la puissance d'entrée estimée (W_{in}) du dispositif d'éclairage à un utilisateur ou pour notifier la puissance d'entrée estimée (W_{in}) du dispositif d'éclairage à un dispositif extérieur,

la partie d'estimation de puissance (83) estime la puissance d'entrée (W_{in}) en utilisant la valeur de réglage de puissance (W_s) et la valeur de détection de courant, en fournissant ainsi une correction de l'estimation de la puissance d'entrée (W_{in}) pour les fluctuations de la valeur de détection de courant provoquées par un changement de la température ambiante de la charge de source de lumière au moyen du calcul suivant :

- calculer un rapport en divisant la valeur de réglage de puissance (W_s) par une valeur de puissance maximale stockée (W_{max}), qui correspond à la valeur de réglage de puissance obtenue en réponse à la puissance maximale fournie à la charge de source de lumière (11), puis multiplier ledit rapport par un coefficient préétabli (α) pour obtenir une première valeur,

- soustraire une valeur d'ajustement de puissance (V_{fb}) de ladite première valeur obtenue en multipliant le coefficient préétabli (α) par ledit rapport de la valeur de réglage de puissance (W_s) sur la valeur de puissance maximale (W_{max}), la valeur d'ajustement de puissance (V_{fb}) correspondant à une différence entre la valeur de réglage de puissance (W_s) et la valeur de détection de courant et dans lequel la valeur du coefficient (α) est supérieure à la valeur d'ajustement de puissance (V_{fb}).

2. Equipement d'éclairage (13) comportant un corps principal d'équipement (130) comprenant le dispositif d'éclairage selon la revendication 1, et la charge de source de lumière (11) tenue par le corps principal d'équipement (130).

3. Système d'éclairage comportant une pluralité des équipements d'éclairage (13) selon la revendication 2, et un dispositif de lecture pour lire le résultat d'estimation de la partie d'estimation de puissance (83) en recevant un signal de communication transmis par la partie de présentation.

Figure 1

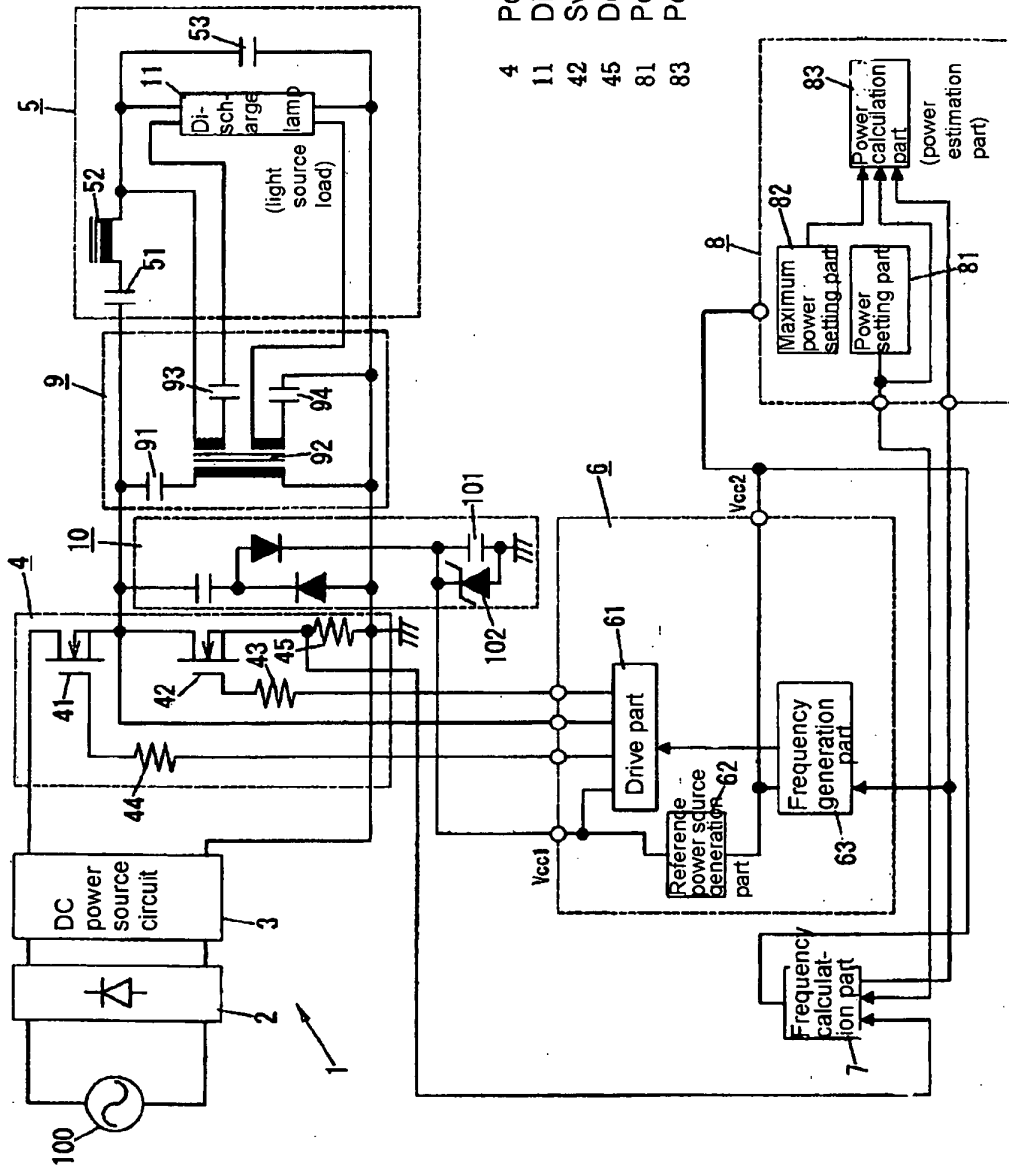

- 4 Power conversion circuit (power conversion part)
- 5 Discharge lamp (light source load)
- 9 Switching element
- 10 Detection resistor (current detection part)
- 11 Power setting part
- 83 Power calculation part (power estimation part)

Figure 2

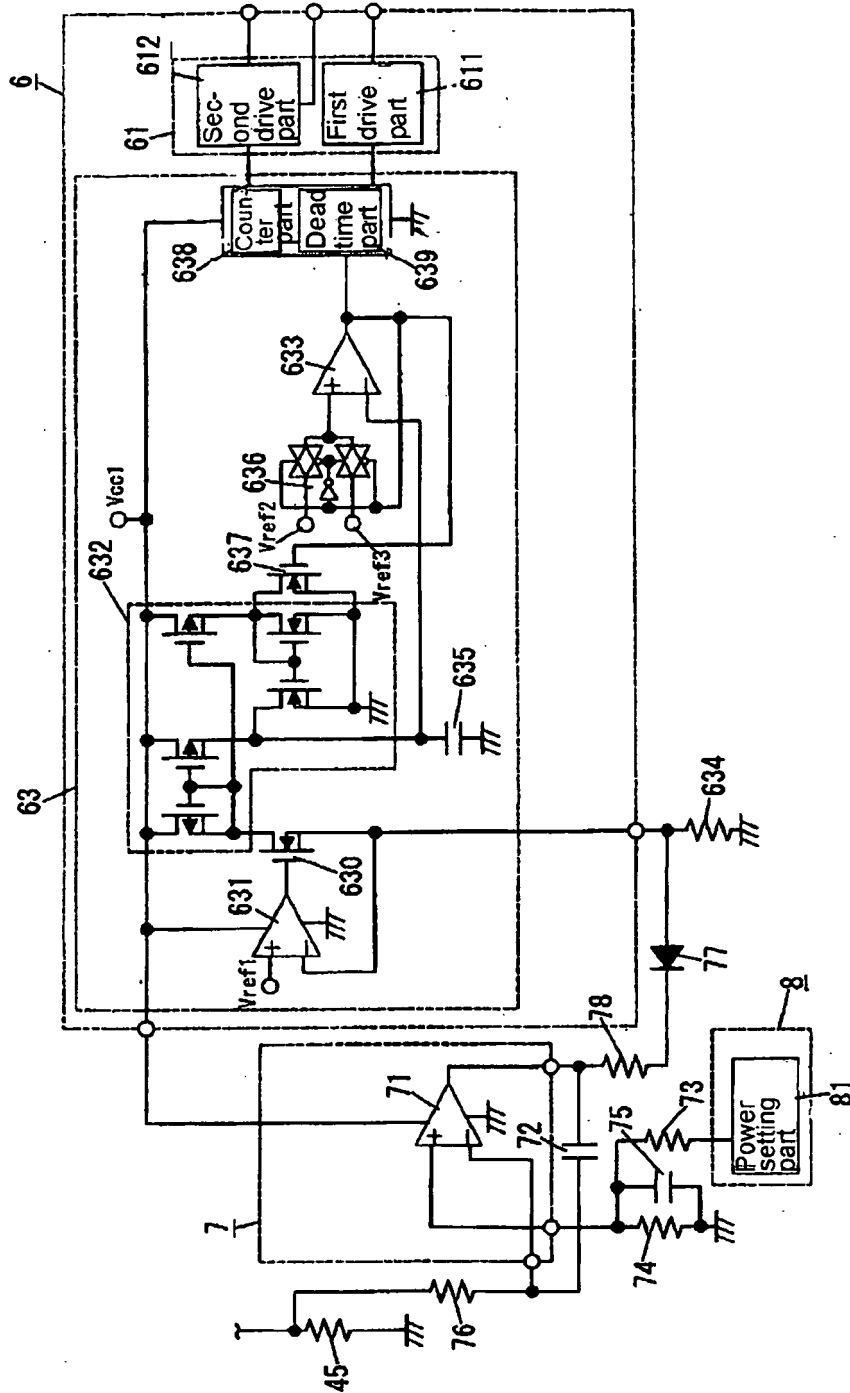

Figure 3

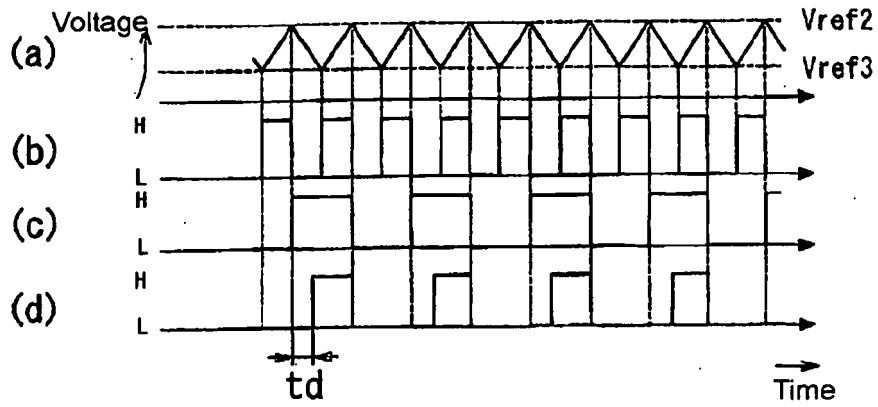

Figure 4

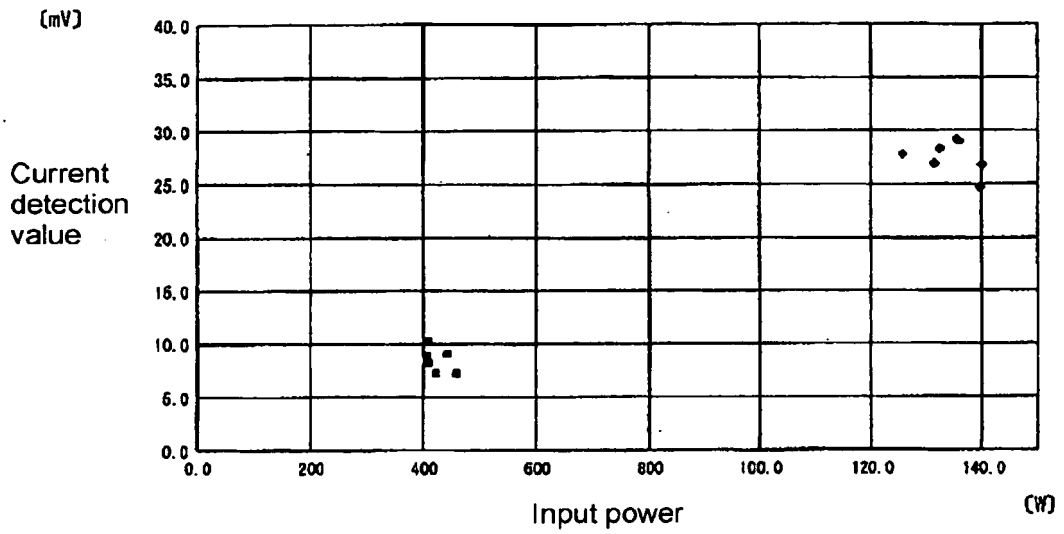

Figure 5

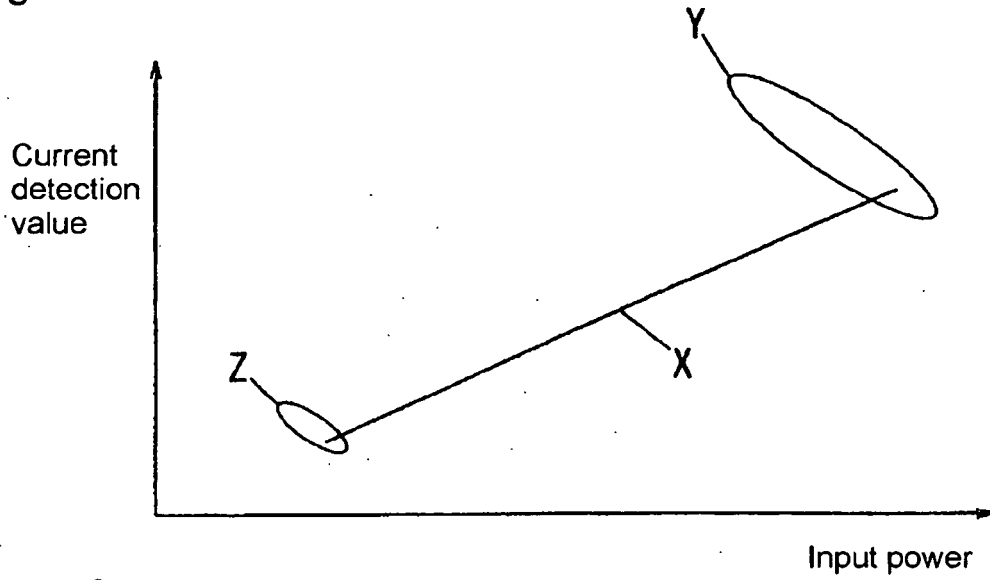

Figure 6

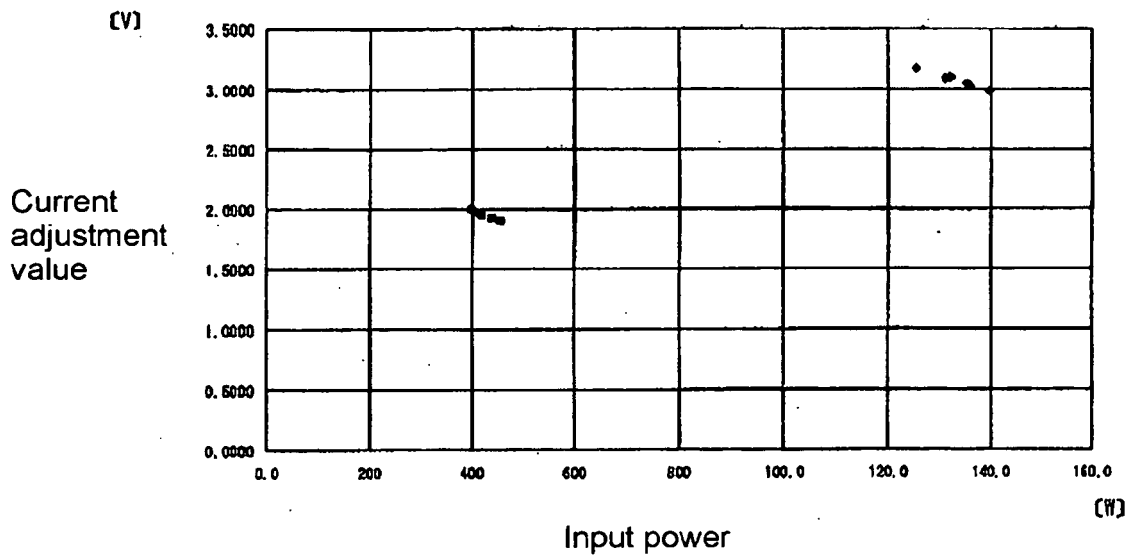

Figure 7

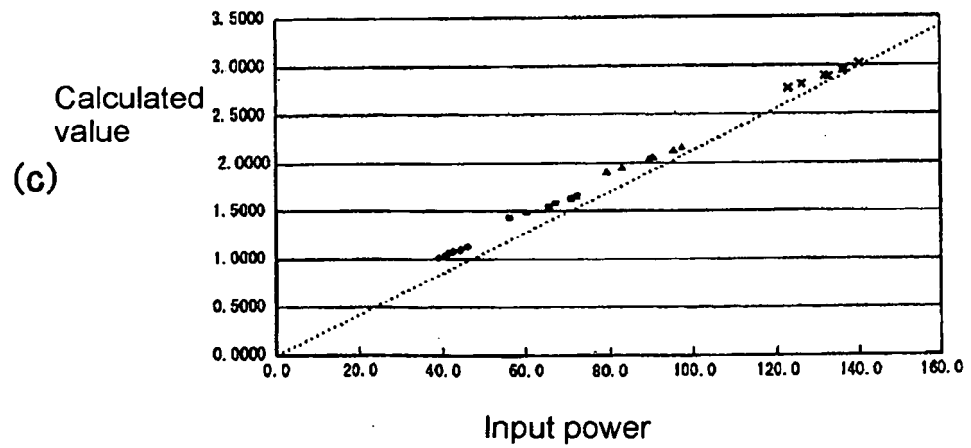
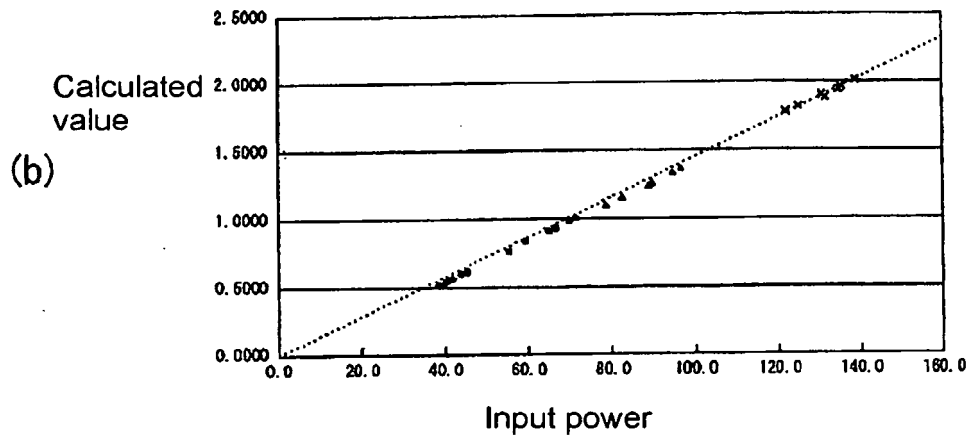
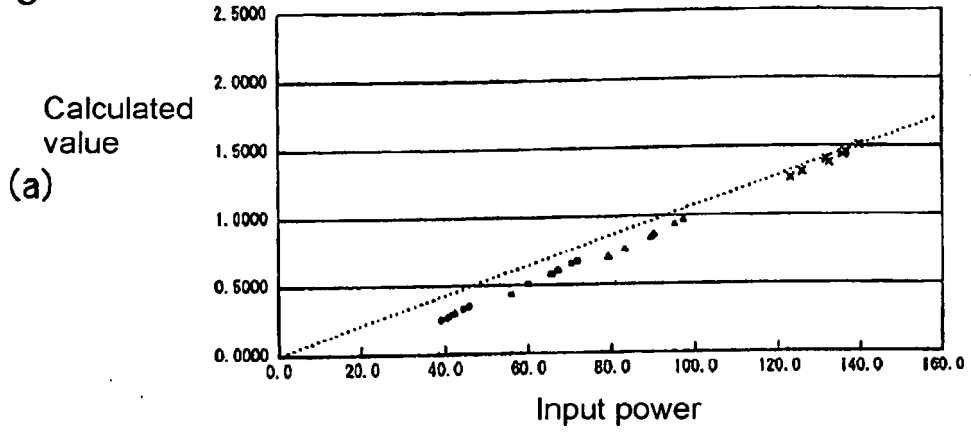

Figure 8

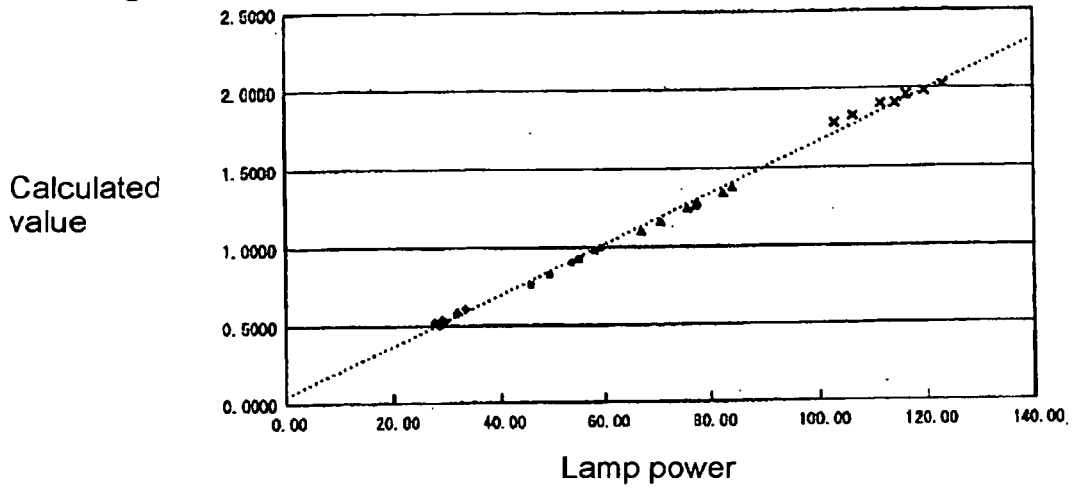

Figure 9

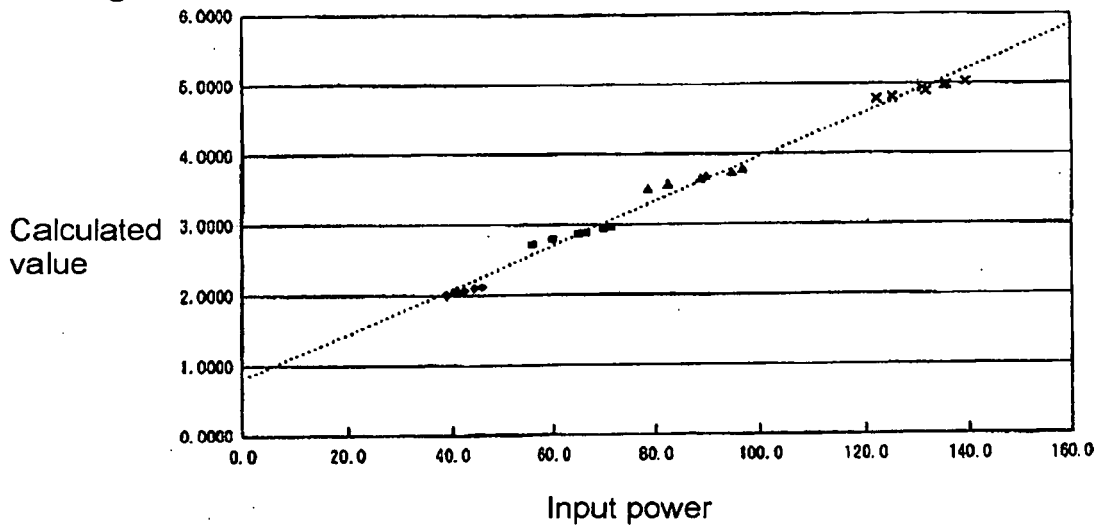

Figure 10

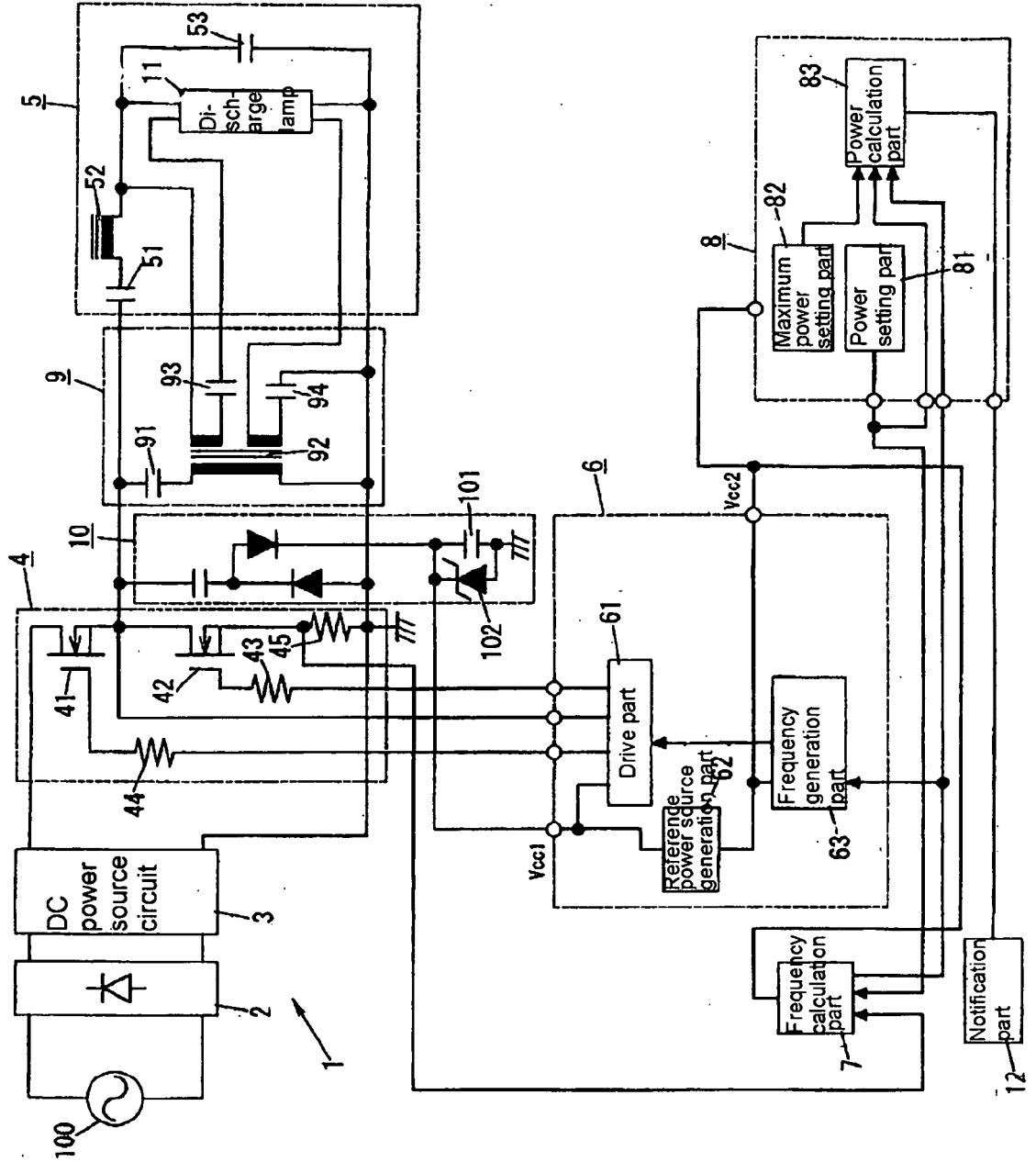
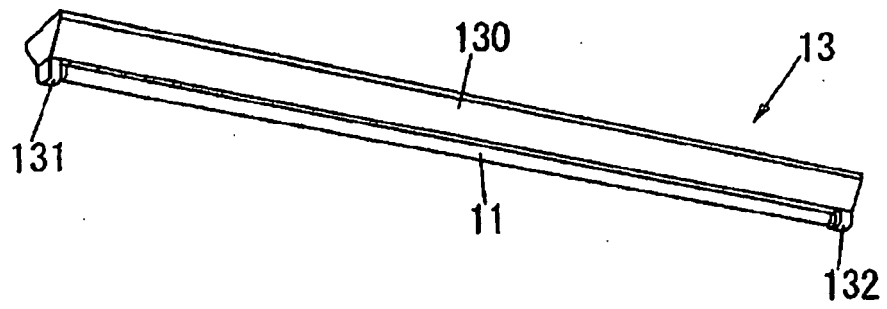

Figure 11



REFERENCES CITED IN THE DESCRIPTION

This list of references cited by the applicant is for the reader's convenience only. It does not form part of the European patent document. Even though great care has been taken in compiling the references, errors or omissions cannot be excluded and the EPO disclaims all liability in this regard.

Patent documents cited in the description

- JP 6413695 T [0007]
- JP 3168842 B [0007]
- US 20100013393 A1 [0008]