

United States Patent [19]

Hansen et al.

[11] **3,864,688**

[45] **Feb. 4, 1975**

- [54] **CROSS-POLARIZED PARABOLIC ANTENNA**
- [75] Inventors: **Laurence H. Hansen**, Oak Lawn; **Robert E. Massey**, Oak Forest; **Aloysius Wojnowski**, Worth, all of Ill.
- [73] Assignee: **Andrew Corporation**, Orland Park, Ill.
- [22] Filed: **Mar. 26, 1974**
- [21] Appl. No.: **454,814**

Related U.S. Application Data

- [63] Continuation of Ser. No. 331,172, Feb. 9, 1973, which is a continuation of Ser. No. 237,727, March 24, 1972, abandoned.
- [52] **U.S. Cl.**..... 343/756, 343/840, 333/21 A
- [51] **Int. Cl.**..... **H01q 19/14**, H01q 1/16
- [58] **Field of Search** 343/756, 779, 840, 912; 333/21 R, 21 A

[56] **References Cited**

UNITED STATES PATENTS			
2,526,383	10/1950	Meier.....	333/21 A
FOREIGN PATENTS OR APPLICATIONS			
1,041,545	9/1966	Great Britain.....	343/854
913,171	12/1962	Great Britain.....	343/768
1,023,112	3/1966	Great Britain.....	343/768

Primary Examiner—Eli Lieberman
Attorney, Agent, or Firm—Wolfe, Hubbard, Leydig, Voit & Osann, Ltd.

[57] **ABSTRACT**
 A cross-polarized parabolic antenna employs a horn fed by two rectangular waveguides having their longer transverse dimension in a common plane, with a 90° polarization rotator in the feed between the connection points of the waveguide.

7 Claims, 6 Drawing Figures

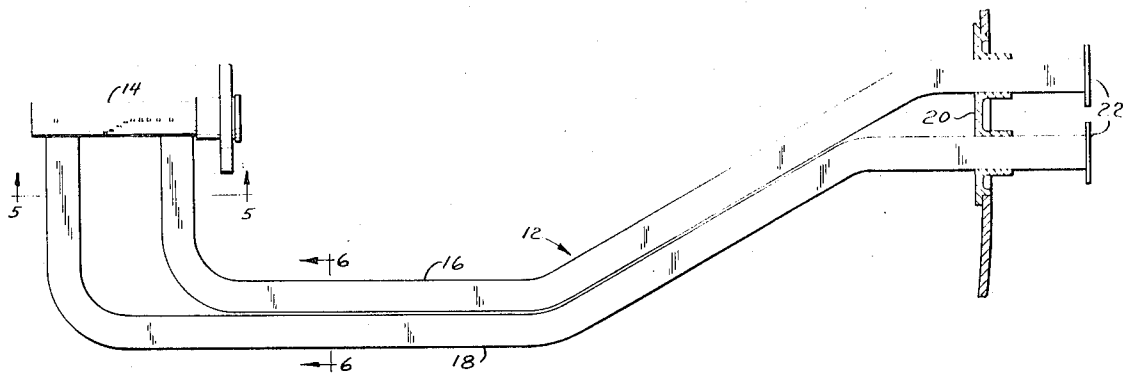

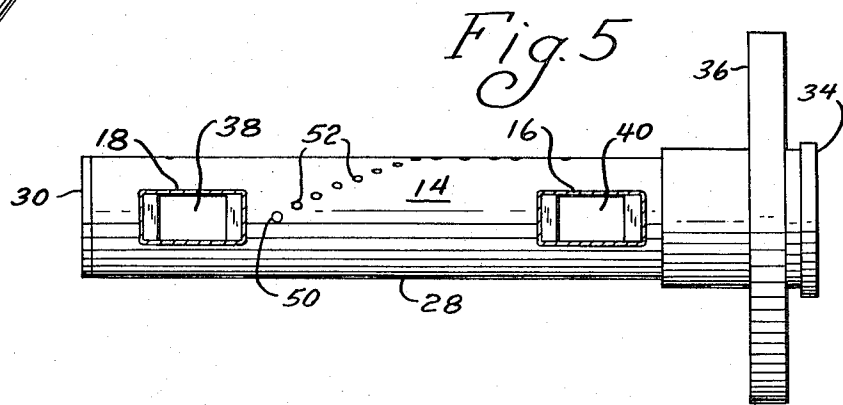
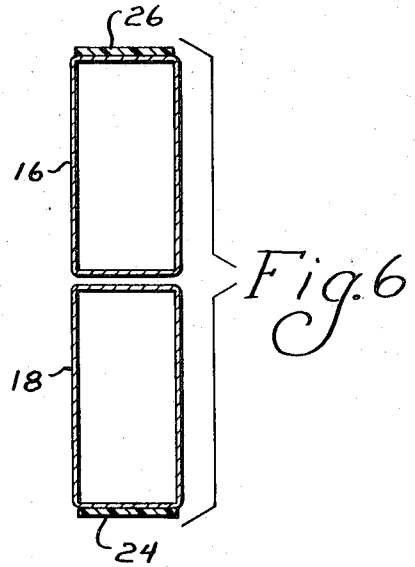
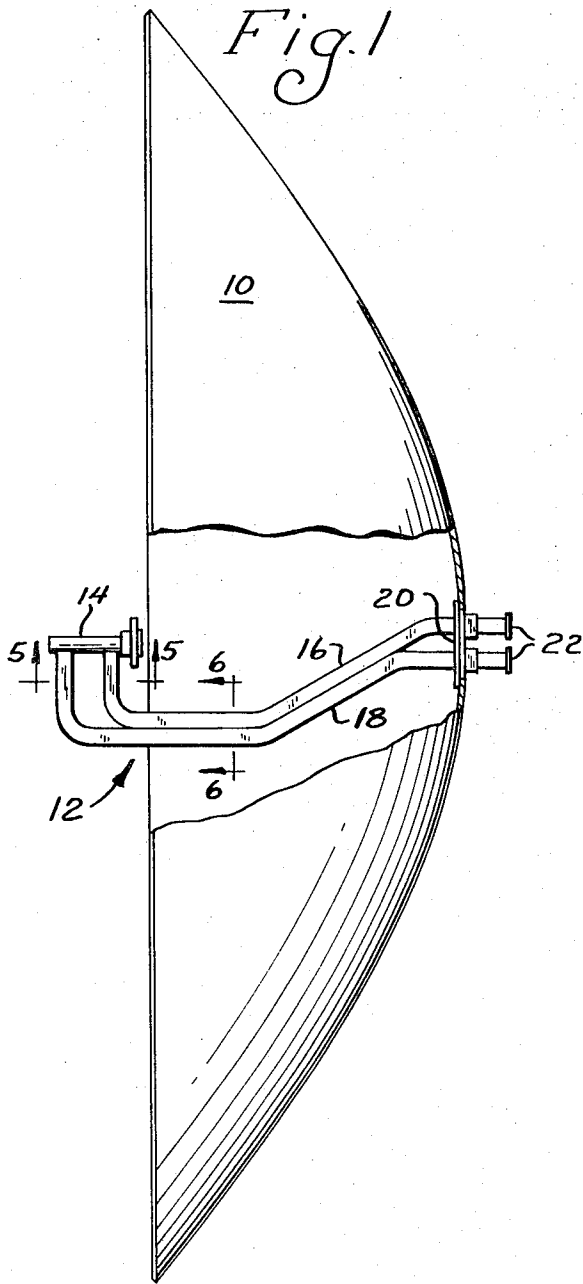

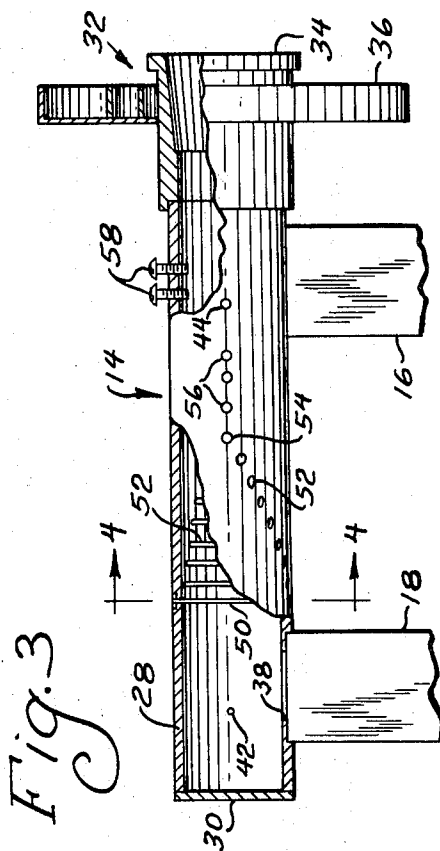
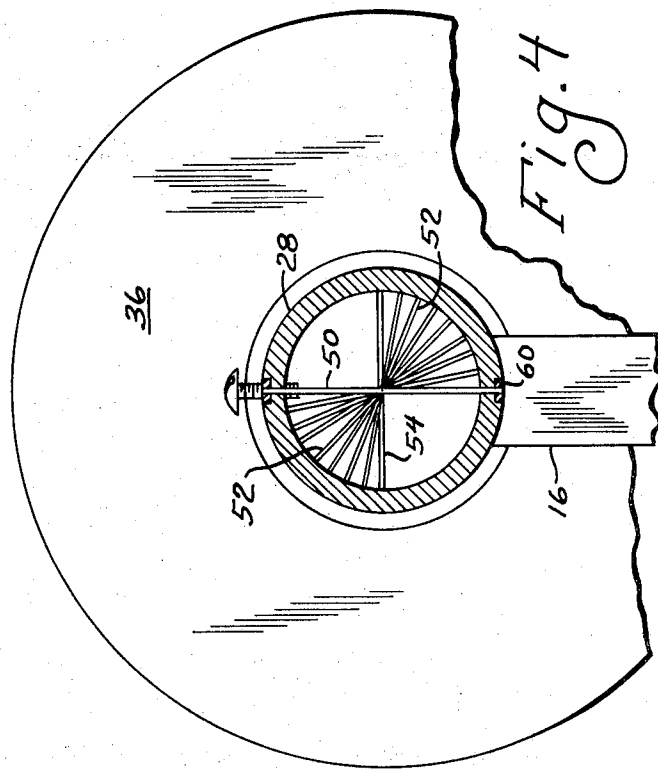
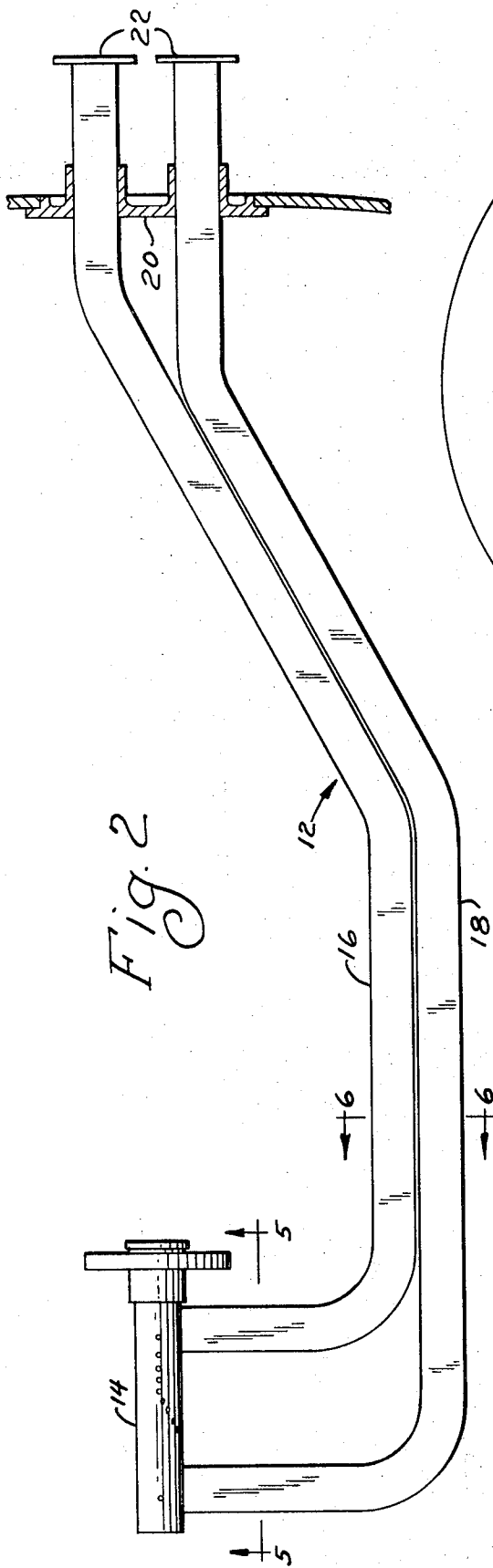

CROSS-POLARIZED PARABOLIC ANTENNA

This is a continuation of application Ser. No. 331,172, filed Feb. 9, 1973, which in turn is a continuation of application Ser. No. 237,727, filed Mar. 24, 1972, now abandoned.

This invention relates to dual-polarized parabolic antennas, and more specifically to cross-polarized feed assemblies for such antennas.

Rectangular waveguide bent in the so-called "button-hook" configuration is commonly employed in connection with feed-horns of parabolic reflector antennas. For dual or cross-polarized antennas, two waveguides are employed, and various modified forms of the button-hook configuration have been employed for the two waveguides.

The present invention lies in an improved construction for the feed assembly of such an antenna. A typical prior construction for such a feed assembly is shown in U.S. Pat. No. 3,599,219. The present invention constitutes an improvement on such a construction as there shown in respects including improvement of the radiation pattern and VSWR and reduction of the forward extension of the feed assembly from the plane of the front edge of the reflector dish.

In the present invention, as in the patent just mentioned, two rectangular waveguides are used with a horn feed, each of the waveguides being employed for one of the two linearly polarized signals. In the present invention, however, unlike past constructions, the longer transverse dimensions of both rectangular waveguides are in a common plane, rather than orthogonal planes, throughout the entire length of the waveguides. Both waveguides, at their points of connection to the feed, have the same direction of polarization for the fundamental mode. Within the feed, between the spaced points of connection of the guides, is a 90° polarization rotator which produces orthogonality of the radiations of the respective waveguide signals appearing at the mouth. Both of the waveguides have their ends extending radially from the feed at the points of connection to minimize the forward extension of the feed assembly.

There is found to be achieved both a substantial reduction of pattern distortion due to aperture blockage and an appreciable improvement in VSWR, as well as reduction of the size of the overall feed assembly in the axial direction. The latter greatly reduces the required bulk of a radome while at the same time adding to the rigidity of the overall structure as well as reducing the required length and simplifying the fabrication of the waveguide portion of the assembly.

Although the novel construction for producing cross-polarized radiations which is provided by the invention is of greatest advantage in antenna-feed construction, wherein the cross-polarized signals are produced close to the mouth of the feed and released for unguided propagation after traversing only a negligible length of guide, it will be obvious to those skilled in the art that the transition construction may also be advantageously employed in producing cross-polarized signals for guided propagation through greater lengths of waveguide. (It will be understood that the specific discussion herein of only one direction of propagation is reciprocally applicable to the opposite direction.)

The invention, in implementing the general aspects described, incorporates further features of novelty best

understood by reference to the embodiment illustrated in the drawing, in which:

FIG. 1 is a view in side elevation of a parabolic reflector antenna and its feed assembly, the former partially broken away in section;

FIG. 2 is an enlarged view of the feed assembly shown in FIG. 1;

FIG. 3 is a further enlarged elevational view, partially in section, of the feed portion of the assembly;

FIG. 4 is an enlarged sectional view along the lines 4—4 of FIG. 3 in the direction indicated by arrows;

FIG. 5 is a sectional view along the line 5—5 of FIGS. 1 and 2 in the direction indicated by arrows; and

FIG. 6 is an enlarged sectional view along the line 6—6 of FIGS. 1 and 2 in the direction indicated by arrows.

The antenna of FIG. 1 consists of a parabolic reflector or dish 10 with its feed assembly 12 consisting of a feed 14 having its mouth or radiating portion effectively at the parabolic focus and a pair of waveguides 16 and 18 mounting and supporting the feed 14 as well as serving for transmission of the respective signals thereby carried. Guy wires which may be employed for stabilization of the portion of the feed, as is conventional in large dish antennas, are omitted from the drawing.

The guides 16 and 18 extend through a center plate 20 at their inner end and terminate in coupling flanges 22. The guides 16 and 18 are formed with bends generally similar to conventional button-hook shaping, but with the outer or forward end of both being wholly radial at the respective points of connection to the feed. Both of the rectangular guides have their long dimension, the H-plane dimension, aligned in a common radial plane throughout their length, so that the aperture blockage produced by the two waveguides is substantially that of a single waveguide. All bends in both guides are in the H-plane; the effect of the bends on VSWR is thus minimized. The guides are closely adjacent to each other in the relatively long median portion of their length and one short side of each waveguide, the outer, is covered with absorber 24 and 26, respectively, in an overall manner resembling a single waveguide.

The feed 14 has a body 28 in the form of a circular tube closed by a shorting cap 30 at the outer end (the end farthest from the reflector) and having a radiating horn assembly 32 at the inner end. The circularly cylindrical horn or mouth 34 has a set-back surrounding choke and reflector 36 of the type described in U.S. Pat. No. 3,553,707 for uniformity of illumination of the large-aperture reflector 10.

The rectangular guides 16 and 18 are coupled to the circularly cylindrical feed 14 through laterally constricted apertures 38 and 40 in opposite end portions of the wall of the tube body 28, the constriction producing the required impedance transformation in the coupling from the rectangular guide to the circular feed.

The waveguide transmission is of course in the dominant mode, with linear polarization across the short or E-plane dimension, so that the direction of polarization of the signal from both waveguides 16 and 18 is in the same direction (perpendicular to the drawing of FIG. 3) at the points of connection to the feed 14. In each case a pin or rod 42 and 44, respectively, extending diametrically across the tube in the direction of the elec-

tric field, directs the propagation inward (note that radiation from the feed in the direction to illuminate the dish is herein designated as inward).

In the central longitudinal region of the feed, between the waveguide couplings, is a series of closely spaced diametric conducting pins. As seen in FIGS. 3 and 4, the pin 50 inwardly adjacent to the waveguide 18 is orthogonal to the polarization direction in that waveguide. The succeeding pins 52 are longitudinally spaced at intervals small compared to the diameter, and thus very small compared to a wavelength, and extend across the tube at successive small progressive angles, this series terminating in a pin 54 parallel with the pins 42 and 44, i.e., in the direction of waveguide electric-field polarization. Further pins 56 are parallel with pin 54. There is thus formed a polarization rotator which twists the plane of polarization of the signal of the waveguide 18 by 90°, the pins 56 stabilizing the rotated polarization direction of the signal for transmission of the mouth of the feed while at the same time aiding the effectiveness of the pins 44 in blocking propagation of the signal of the waveguide 16 in the undesired outward direction, thus minimizing cross-talk between the signals. Tuning screws 58 are provided for optimization of performance.

Although the employment of closely longitudinally spaced pins, secured by solder 60, is a simple and convenient manner of forming the rotator, the overall action is that of a twisted conducting baffle extending diametrically across the tube, with the pins 56 constituting in essence a planar extension. Thus a continuous conductor in the form of a foil or vane may be employed if desired, as may other forms of polarization rotator, although less advantageously.

In the antenna feed described, the cross-polarized radiation is thus produced closely adjacent to the flared horn or mouth 34 and propagates through only the very short length of the waveguide feed which couples to the flare. However it will be readily seen that the same transition or coupling between the two rectangular guides and a circular guide may advantageously be used wherever it is desired to feed cross-polarized radiations to a circular guide with improved VSWR as compared with prior art transitions for the purpose, particularly in installations where the co-planar orientation of

the rectangular guides at the juncture with the circular guide which characterizes the present invention enables use of H-plane bends throughout the runs of the rectangular guides.

Many other detailed forms of the invention will readily be devised by persons skilled in the art. Accordingly, the scope of the protection to be afforded the invention should be determined only in terms of the structures defined in the annexed claims, and equivalents thereof.

What is claimed is:

1. In a cross-polarized antenna comprising a parabolic reflector, a horn feed at the focus of the reflector, a pair of rectangular waveguides connected to the feed, the improvement characterized by the longer transverse H-plane dimension of both waveguides being aligned in a common radial plane, and the feed including a 90° polarization rotator between the point of connection of one waveguide and the point of connection of the other.

2. The cross-polarized antenna of claim 1 further characterized by the feed comprising a circular tube extending along the parabolic axis and having the respective waveguides connected adjacent to opposite ends thereof.

3. The cross-polarized antenna of claim 2 characterized by the polarization rotator comprising conductor means between the waveguide connections extending diametrically across the tube and forming a 90° twisted baffle with the outer end in said common plane and the inner end perpendicular thereto.

4. The antenna of claim 3 wherein the conductor means comprises a series of closely spaced pins extending across successively slightly rotated diameters.

5. The antenna of claim 3 having added conductor means forming a planar extension of said inner end to form an isolation section blocking undesired outward propagation from the other waveguide connection.

6. The antenna of claim 1 having the outer ends of both waveguides extending radially from the feed.

7. The antenna of claim 6 having the inner ends of both waveguides extending axially through the reflector, both waveguides being bent solely in their common H-plane.

* * * * *

50

55

60

65