



INTERNATIONAL APPLICATION PUBLISHED UNDER THE PATENT COOPERATION TREATY (PCT)

<p>(51) International Patent Classification ⁵ : A61N 1/30</p>	<p>A1</p>	<p>(11) International Publication Number: WO 91/18642 (43) International Publication Date: 12 December 1991 (12.12.91)</p>
<p>(21) International Application Number: PCT/US90/03015 (22) International Filing Date: 30 May 1990 (30.05.90) (71) Applicant: NOVEN PHARMACEUTICALS, INC. [US/US]; 13300 S.W. 128th Street, Miami, FL 33131 (US). (72) Inventor: LAPRADE, Ronald, E. ; 7520 S.W. 126th Street, Miami, FL 33156 (US). (74) Agent: MELOY, Sybil; Foley & Lardner, 501 Brickell Key Drive, Suite 403, Miami, FL 33313 (US). (81) Designated States: AT, AT (European patent), AU, BE (European patent), BG, BR, CA, CH, CH (European patent), DE*, DE (European patent)*, DK, DK (European patent), ES, ES (European patent), FI, FR (European patent), GB, GB (European patent), HU, IT (European patent), JP, KR, LU (European patent), NL, NL (European patent), NO, RO, SE, SE (European patent), SU.</p>		<p>Published <i>With international search report.</i> <i>With amended claims and statement.</i></p>
<p>(54) Title: METHOD AND APPARATUS FOR IONTOPHORETIC DRUG DELIVERY</p>		
<div style="text-align: center;"> </div>		
<p>(57) Abstract</p>		
<p>An iontophoretic device for delivery of a drug comprising a flexible, non-conductive backing (12); first (16) and second (18) conductive electrodes composed of a substantially non-ionizing material in a plane, one side of the plane which is optionally attached to the optionally flexible backing (12), and the other side of the plane which is adapted to be affixed to one side of a flexible and electrically conductive layer containing the drug to be delivered; a source (34) of electrical current and an integrated circuit (30) containing means for reversing the polarity of the two electrodes. The device can additionally include the conductive layer containing the drug to be delivered, affixed to the plane of the two electrodes. An ion exchange membrane can optionally be disposed between the two electrodes and the drug-containing layer. The integrated circuit (30) can optionally contain pulsing means or current varying means or both to vary the amount of current delivered from time to time or in absolute amount.</p>		

DESIGNATIONS OF "DE"

Until further notice, any designation of "DE" in any international application whose international filing date is prior to October 3, 1990, shall have effect in the territory of the Federal Republic of Germany with the exception of the territory of the former German Democratic Republic.

FOR THE PURPOSES OF INFORMATION ONLY

Codes used to identify States party to the PCT on the front pages of pamphlets publishing international applications under the PCT.

AT	Austria	ES	Spain	MG	Madagascar
AU	Australia	FI	Finland	ML	Mali
BB	Barbados	FR	France	MN	Mongolia
BE	Belgium	GA	Gabon	MR	Mauritania
BF	Burkina Faso	GB	United Kingdom	MW	Malawi
BG	Bulgaria	GN	Guinea	NL	Netherlands
BJ	Benin	GR	Greece	NO	Norway
BR	Brazil	HU	Hungary	PL	Poland
CA	Canada	IT	Italy	RO	Romania
CF	Central African Republic	JP	Japan	SD	Sudan
CG	Congo	KP	Democratic People's Republic of Korea	SE	Sweden
CH	Switzerland	KR	Republic of Korea	SN	Senegal
CI	Côte d'Ivoire	LI	Liechtenstein	SU	Soviet Union
CM	Cameroon	LK	Sri Lanka	TD	Chad
CS	Czechoslovakia	LU	Luxembourg	TC	Togo
DE	Germany	MC	Monaco	US	United States of America
DK	Denmark				

METHOD AND APPARATUS FOR
IONTOPHORETIC DRUG DELIVERY

BACKGROUND OF THE INVENTION

The present invention relates to transdermal (transcutaneous) drug applicators and methods of their use, as well as to a drug-containing medium for use with such applicators, and more particularly to iontophoretic drug applicators which are electrically operated and which exhibit properties which facilitate the transcutaneous delivery or transfer of drugs, and the like.

Iontophoresis has come into increasing attention as an effective method for the topical application of drugs through the skin to exert a systemic effect.

Iontophoresis is the technique of delivering ionic, ionizable or polar drugs through a person's skin, by placing a solution or other medium containing the ions, ionizable or polar substances in contact with the skin, and applying electric current to the medium. The medium containing the ions, ionizable or polar substance may be a fluid or a solid and is in contact with a first electrode. Ions

are caused to migrate from the medium through the skin or tissue by the application of electric current from the first electrode, to the medium and then to a second electrode spaced from the first electrode.

Iontophoretic devices have been designed so that one electrode is in contact with the medium containing the drug of like charge to that of the electrode, while the second electrode is in contact with a medium lacking such drug. Alternatively, the second electrode can be in contact with a different drug having a charge the same as that of the second electrode.

In addition, iontophoretic devices have been proposed containing pulsing means, namely means for effecting depolarization of the electrodes at spaced intervals, in an attempt to lower the voltage needed for the iontophoresis.

The overall size of the iontophoretic device should desirably be minimized for cost effectiveness and aesthetics, and the dosage capability maximized.

It is an object of the present invention to provide improved iontophoretic devices comprising two electrodes insulated from each other, that is minimum in size and capable of maximum drug delivery, and yet reasonable in cost.

It is a further object of the present invention to provide an improved iontophoretic system utilizing improved electrode construction, which permits delivery of a single drug through both electrodes, by use of a means to reverse the polarity of the two electrodes. The means for reversing the polarity of the two electrodes can be an electronic switching device, which can optionally be coupled to a pulse generating device. The pulse generating device permits the delivery of electrical current in

pulses, which, in cooperation with the electronic switching device, can be timed to reverse the polarity of the electrodes at spaced intervals related to the pulses, or independent of the pulses. Still another object of this invention is an iontophoretic device having means to vary the amount of current delivered to the device.

Another object of this invention is the provision of a drug-containing medium for use in the iontophoretic device, which layer is backed on both sides with a pressure sensitive adhesive.

These and other objects and advantages of the invention, will become more apparent from a reading of the following detailed description of the preferred modifications and embodiments of the invention.

SUMMARY OF THE INVENTION

An iontophoretic device for delivery of a drug comprising a flexible, non-conductive backing; first and second conductive electrodes composed of a substantially non-ionizing material in a plane, one side of the plane which is optionally attached to the optionally flexible backing, and the other side of the plane which is adapted to be affixed to one side of a flexible and electrically conductive layer containing the drug to be delivered; a source of electrical current and means for reversing the polarity of the two electrodes. The device can additionally include the conductive layer containing the drug to be delivered, affixed to the plane of the two electrodes. An ion exchange membrane can optionally be disposed between the two electrodes and the drug-containing layer. The device can optionally contain pulsing means or current varying means or both

to vary the amount of current delivered from time to time or in absolute amount.

DESCRIPTION OF THE DRAWINGS

Fig. 1 is a top view of the first embodiment of the present invention.

Fig. 2 is a bottom view of the invention of Fig. 1.

Fig. 3 is a cross-section of the invention of Fig. 1.

Fig. 4 is a block diagram of the electrical circuit for the device shown in Fig. 3.

Fig. 5 is an electrical schematic drawing of the circuit of the polarity switching device used with the invention of Fig. 3.

Fig. 6 is a top view of the drug-containing conductive gel layer used with the invention of Fig. 3.

Fig. 7 is a cross-sectional view of the drug layer of Fig. 6.

Fig. 8 is a top view of a second embodiment of the present invention.

Fig. 9 is a cross-sectional view of the second embodiment of the present invention.

DETAILED DESCRIPTION OF THE INVENTION

The present invention generally provides an iontophoretic device which comprises:

an optionally flexible, non-conductive backing;

first and second conductive electrodes in a plane, one side of which is optionally attached to a flexible backing, and composed of a substantially non-ionizing material;

an optional conductive layer

containing the drug to be delivered affixed to the two electrodes in communication;

a source of electrical current;

means for reversing the polarity of the two electrodes;

an optional pulsing generator to cause the current to be delivered to the electrodes in discrete segments;

an optional current regulator to vary the voltage of the current to be delivered;

an optional ion exchange membrane carried between the electrodes and the drug-containing layer; and

an optional, pressure-sensitive adhesive on each side of the drug-containing layer, to hold said layer in contact with the electrodes on one side and with the skin on the other side.

Referring to Figs. 1, 2 and 3, there is shown a first embodiment of iontophoretic device 10 which comprises a non-conductive polymeric, outer-layer 12 of polyvinylchloride, or other flexible, non-conductive backing material. On the reverse side of the iontophoretic device 10, shown in Fig. 1, as shown in Fig. 2, there is a layer 14 serving as a dual electrode. Layer 14 comprises a conductive material, such as copper, silver or molybdenum metals, or other substantially non-ionizing material. Specifically, the layer 14 is composed of a material that will not cause the formation of substantial amounts of ions in competition with those of the ionized drugs, such as

hydronium ions. An insulating material 20 in Figs. 2 and 3, acts to separate layer 14 into two portions 16 and 18, which thus permits the two portions to serve as electrodes of opposite charge.

Referring to Fig. 3, a layer 30 is a thin integrated circuit containing a direct current pulse generator, a current regulator circuit and a polarity switching means (not shown in Fig. 3).

Fig. 4 is a block diagram of a system used to permit pulsing and polarity switching of the device. In Fig. 4, electrical pulse-generating device 36 is connected to polarity switching device which is connected to anode 38 and cathode 39 sections of the device. The battery 34 is connected to the pulse generating device via suitable electrical conducting materials. Some suitable pulse generating devices are described in Sasaki, European Patent application No. 84305910.6, assigned to Kabushiki Kaisya Advance Kashatsu Kenkyujo, the disclosure of which is incorporated by reference.

By means of the time relay device 36, the polarity of the iontophoretic device can be changed at some number of pulses to obtain an active to indifferent electrode ratio to obtain maximum delivery of the ionized drug used.

The layer 30 of Fig 3 can be provided with an external current generator and switching device, a schematic representation of which is shown schematically in Fig. 5. A battery 34 consists of multiple layers of conductive flexible polymers in a gel substance that will generate voltage to the pulse generating device and is electrically connected to the polarity switching device 50. The insulating material 20 shown in Figs. 2 and 3 absorbs excess

moisture from the drug layer to prevent any shorting of the two electrodes during operation.

Fig. 5 is a circuit diagram of switch means permitting reversal of the polarity of the electrodes with desired time period and consists of a time relay circuit or any other timing circuit incorporated into the total circuit of Fig. 4.

The operation of the device incorporating the circuit of Fig. 5 is as follows: A constant power source is obtained from the battery 34 and is used to power the timing circuit 42 of the timed relay 50. A microswitch 60 is provided in the device to turn on time relay 50 when drug matrix is affixed to the iontophoretic device. Relay 41 is timed via timing circuit 42, so that the relay contacts 49 change positions after the desired number of pulses. During this period, the pulsing device, pulse current at connection 46 from pulsing device 36, is in electrical contact with active electrode 43 while indifferent electrode 44 is in contact with connection 47 from pulsing device. At the end of desired number of pulses and when time relay time is zero, contacts 49 change position (power is applied to relay coil 40), so that connection 46 is now in contact with the now active electrode 44 and connection 47 is in contact with the now indifferent electrode 43. The timing circuit of timed relay 50 is reset automatically at the end of each pulsing period thereby timing up during one period and timing down during the next period. By so changing polarity of the active and indifferent electrode after each set of pulses (periods) the drug delivers in both portions of the device shown in Fig. 2 and is maintained during subsequent periods of the pulsing device.

A plane view and a cross-section view of the conductive gel (or other supporting conductive media), containing the drug is illustrated in Fig. 6. In the cross-section shown in Fig. 7, a conductive adhesive layer 53 is laminated to the top of ionic membrane 55. Ionic membrane 55 is laminated to the gel layer 52 containing the drug for contact with the skin. Insulator 56 separates the two equal halves of the conductive gel for contact with the two electrodes and prevents shorting the drug gel matrix to reduce current density concentrations at any spot smaller than the electrode surface area.

One conductive material for use in making a gel layer includes, for example, the resinous polysaccharide karaya gum. Other conductive materials that can be used to form a gel include tragacanth gum, polyvinyl alcohol, polyvinyl methacrylate, polyacrylic acid, polyacrylic esters. These natural and synthetic resins are combined with water or polyols, such as ethylene glycol and glycerin. Additives such as polyethylene glycol, propylene glycol and dipropylene glycol in combination with oleic acid can be added to the gel to improve drug delivery through the skin, thus reducing the current density to deliver a given drug.

An ionized drug or conductive salts thereof are mixed with the aforementioned material making the gel more conductive for iontophoresis. Release liner 54 can be used on both sides of the gel layer to protect pressure sensitive adhesives until they are applied to the patient for drug delivery.

The device of Figs. 8 and 9 is a second embodiment of the invention which utilizes an external power source, a pulse generating device, and a polarity reversing device for delivering higher

current densities than are possible by the devices shown in Figs. 1 to 3. In Figs. 8 and 9 shown outer layer 10a is a polymeric non-conductive material, and 14a corresponds with dual electrodes of Figs. 2 and 3. Insulator 20a separates the two electrodes of the device. The device in Figs. 8 and 9 has an additional electrical connector 74 connected to the external power source, pulse generating and polarity switching device 75. The device 75 is equipped so that pulse frequency, current density and polarity switching period is adjustable.

The cathode and anode of the device of this invention are made of component materials such as silver, cooper, molybdenum, stainless steel or other materials that will either (1) be "sacrificial", meaning they will oxidize during operation, or (2) resist corrosion during subsequent operation.

If karaya gum is used for the gel layer, it will be electrochemically conductive and will be more desirable for contact with skin due to high water retention and a natural pH buffer action (pH 4-5).

A karaya gum gel is usually made from approximately 50 parts by weight karaya gum, 25 parts by weight water and 25 parts by weight propylene glycol or glycerin. Due to the high water retention ionic drugs can be added with minimum effect on the gel. The amount of drug added depends on the desired unit dosage per unit time, size of gel layer in contact with active electrode, amount of current used, and other variables.

To the electrode side of the above gel layer is an ion exchange member separating the electrodes and the ionic drug impregnated gel layer for inhibiting the flow of ions of similar charge created by the electrode material. The ion exchange membrane

is made of a microporous material and will vary with drug used in the gel layer.

Suitable ion exchange membranes available under the designation AR103-QZ by Ionics, Inc. and Raipore 4010 and 4035 by RAI Research Corp. The outer surface of the ion exchange membrane is affixed with conductive pressure sensitive adhesive for contacting the electrodes of the iontophoretic device. Both surfaces of the gel layer, including the ion exchange membrane, are covered with a release liner for removal when the drug gel layer is used. The final layer is then pouched in a protective pouch to maintain the drug at the desired concentration until use.

Known devices for pulse generating can be used in this invention. One of these devices comprises a pulse generator and a charge pump type voltage converter circuit for increasing the output current of the pulse. By using this type of voltage increasing device to double or triple the voltage of a thin layer battery, it may be possible to achieve the current to overcome the high resistance of the skin (i.e., skin resistance is of the order of 10K ohms to 1M ohms. Also, by pulsing, higher currents can be applied with less irritation, burns, etc. to the skin under the electrodes.

To the known pulse generating device added for purposes of this invention, is a timed electronic reversing circuit to change the anode and the cathode electrodes at a predetermined time period corresponding to a number of pulses. The number of pulses between reversal of the anode and cathode is determined to give a positive drug delivery at the active electrode before reversing the active electrode to the indifferent electrode. It has been

determined that higher current densities deliver higher concentrations of ionized drug in less time than lower current densities. Therefore, by pulsing higher current to the active electrode the ionized drug is delivered through the skin faster and goes into the bloodstream faster. This prevents the drug from leaving the skin during reversal of the electrodes. The skin also has a tendency to become polar with the charge being used over long periods of continuous iontophoresis, causing increased resistance to ionized drug delivery. Reversing of the electrodes prevents polarization from occurring, thus minimizing the natural resistance of the skin to ionized drug delivery and increasing the amount of drug delivered over time.

A thin layer battery is used to supply power to the current switching, and or pulse generating devices. Such a battery uses thin layers of a flexible conductive polymer material in sheets layered with a gel substance to generate voltage. By employing the current doubling circuit above, the transdermal drug delivery rate can be increased.

The circuit, including the battery, the pulse generating device and the switch device, is layered to reduce the total thickness to the iontophoretic device. The thickness is kept to from 0.5 millimeters which will allow for a device of no more than 1. to 25. millimeters.

The selection of an outer layer is made to protect the electrical circuits and the two electrodes of the device and provide a cavity for the active ionic gel material containing the drug. Materials such as polyethylene and polypropylene, or any non-conductive polymer that can be molded to the desired shape and that offers protection to the

electrode circuit, can be used. However, a polymer that is reasonably flexible so that it bends with the skin is most desirable.

We claim:

1. An iontophoretic device for delivery of a drug comprising:
 - an optionally flexible, non-conductive backing layer;
 - first and second conductive electrodes in a plane composed of a substantially non-ionizing material, attached to one side of which is the backing layer and the other side of which is adapted to be affixed to one side of a flexible and electrically conductive layer containing the drug to be delivered;
 - a source of electrical current; and
 - means for reversing the polarity of the two electrodes.
2. The device of claim 1, which additionally contains a conductive layer containing the drug to be delivered, affixed to the electrodes.
3. The device of claim 2, wherein the conductive layer is a gel containing a drug in ionic form.
4. The device of claim 2 wherein the conductive gel is separated from the electrode by an ion exchange membrane.
5. The device of claim 1, which additionally includes a pulse generator to cause the current to be delivered in timed intervals.
6. The device of claim 5, which further comprises a switch mechanism capable of reversing the polarity of the electrodes after one or more therapeutic pulses.
7. The device of claim 1, which additionally contains a conductive layer containing

the drug to be delivered, one side of the conductive layer carrying an ion exchange member and the other side attached to the two electrodes.

8. The device of claim 7 in which the conductive layer is a gel.

9. The device of claim 7 in which the drug is contained in karaya gel.

10. An iontophoretic device comprising:

a flexible, non-conductive backing layer;

first and second conductive electrodes composed of a substantially non-ionizing material adjacent to the flexible backing layer and adapted to be affixed to one side of a conductive layer containing the drug to be delivered; and

a flexible conductive layer containing the drug to be affixed to the electrodes; and

a source of electrical current; and means for reversing the polarity between the two electrodes during operation.

11. The device of claim 10, wherein the conductive layer is a gel containing an ionic drug.

12. The device of claim 11 wherein the conductive gel further is backed on one side with an ion exchange membrane.

13. The device of claim 1, which additionally includes a pulse generator and means for altering the amount of current to the electrodes in timed intervals.

14. The device of claim 13, wherein the device further comprises a switch mechanism which

reverses the polarity of the electrodes between both electrodes, simultaneously with the interval of the therapeutic pulse, to carry out reversal of polarity between both electrodes during an intermission period of the therapeutic pulse.

15. A flexible and electrically conductive material adapted and sized to be affixed to a non-conductive backing layer of an iontophoretic device and containing a drug.

16. The layer of claim 15 which further contains a pressure sensitive adhesive on both sides thereof having sufficient adhesive strength to attach to the skin at one end and to an electrode at the other end.

17. The device of claim 16 which further contains an ion exchange membrane placed between the adhesive layer for contact with the skin and the adjacent flexible, conductive material, which ion exchange membrane attracts ions.

18. An iontophoretic device adapted to be used with a source of electrical current comprising:

- pulse generator;
- two electrodes composed of a substantially non-ionizing material;
- means for reversing the polarity of the two electrodes;
- means for delivering current to the electrodes in pulses; and
- means for varying the voltage of the current.

AMENDED CLAIMS

[received by the International Bureau
on 16 April 1991 (16.04.91)
original claims 2 and 16 cancelled; original claims
1, 3-6, 10, 14, 15, 17 and 18 amended;
other claims unchanged (3 pages)]

1. An iontophoretic device for drug delivery comprising:
a non-conductive backing layer;
first and second electrically conductive layers each
containing a drug to be delivered;

first and second conductive electrodes arranged to be
coplanar and composed of a substantially non-ionizing material,
each of said conductive electrodes having two sides, there being
attached to one side a backing, and the other side being adapted
to be affixed to one side of a respectively associated one of
said electrically conductive layers;

a source of electrical current;
generator means for producing a sequence of electrical
pulses;

timing means for defining a predetermined period of time;
and

polarity reversing means responsive to said timing means for
reversing the polarity of the two electrodes after a predetermi-
nable number of the electrical pulses have been produced by said
generator means.

2. Canceled.

3. The device of claim 1, wherein the conductive layer is
a gel containing a drug in ionic form.

4. The device of claim 1, wherein the conductive gel is
separated from the electrode by an ion exchange membrane.

5. The device of claim 1, wherein said generator means
includes a pulse generator for causing a current to be delivered
to said electrodes in timed intervals.

6. The device of claim 5, wherein said polarity reversing
means comprises a switch mechanism for reversing the direction
of the current delivered to said electrodes.

7. The device of claim 1, which additionally contains a
conductive layer containing

the drug to be delivered, one side of the conductive layer carrying an ion exchange member and the other side attached to the two electrodes.

8. The device of claim 7 in which the conductive layer is a gel.

9. The device of claim 7 in which the drug is contained in karaya gel.

10. An iontophoretic device comprising:

a flexible, non-conductive backing layer;

first and second conductive electrodes composed of a substantially non-ionizing material, each arranged to be adjacent to said backing layer;

a flexible conductive layer containing a drug to be delivered, said flexible conductive layer being affixed to at least one of the electrodes;

a source of electrical current;

pulse means coupled to said source of electrical current for producing a current issued thereby in timed pulses;

means for reversing the polarity between the two electrodes during operation after a predetermined number of said timed pulses.

11. The device of claim 10, wherein the conductive layer is a gel containing an ionic drug.

12. The device of claim 11, wherein the conductive gel further is backed on one side with an ion exchange membrane.

13. The device of claim 1, which additionally includes a pulse generator and means for altering the amount of current to the electrodes in timed intervals.

14. The device of claim 13, wherein said pulse means further comprises a switch mechanism

for reversing the polarity of the electrodes during an intermission period of the timed pulses.

15. A device formed of a flexible and electrically conductive material having two sides and being adapted and sized to be affixed to a non-conductive backing layer of an iontophoretic device, said flexible and electrically conductive material containing a drug, there being further provided a layer of pressure sensitive adhesive on each side thereof having sufficient adhesive strength to attach to the skin of a user at one side thereof to an electrode at the other side thereof, each layer of pressure sensitive adhesive having a release liner removably attached thereto.

16. Canceled.

17. The device of claim 15, which further contains an ion exchange membrane placed between the adhesive layer for contact with the skin of the user and the adjacent flexible, conductive material, which ion exchange membrane attracts ions.

18. An iontophoretic device adapted to be used with a source of electrical energy comprising:

a pulse generator responsive to the source of electrical current for generating therapeutic electrical pulses;

two electrodes composed of a substantially non-ionizing material;

means for coupling the two electrodes to the pulse generator and for reversing the polarity state of the two electrodes after a predetermined number of the therapeutic electrical pulses; and

means for timing a period during which the electrodes are in a polarity state.

STATEMENT UNDER ARTICLE 19

Independent claims 1, 10, and 18 have been amended to specify subject matter relating to the electrical pulsing system, particularly a generator which generates a sequence of electrical pulses during a predetermined time, such that a predetermined number of pulses are issued before the polarity of the electrodes is reversed. It is respectfully asserted that these amended independent claims specify subject matter which is not taught or suggested by the prior art of record.

Independent claim 15 has been amended to specify with greater precision the layers of adhesive material, one on each side of the device, and a release liner which can be removed easily so the device can be coupled to the electrode on one side thereof, and the skin of the wearer on the other. This combination of elements is not present in the prior art of record.

In view of the foregoing, it is believed that the present international application specifies subject matter which is allowable over the prior art of record.

FIG. 1

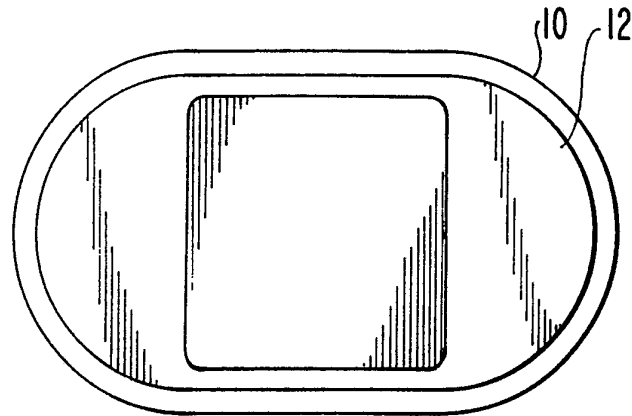

FIG. 2

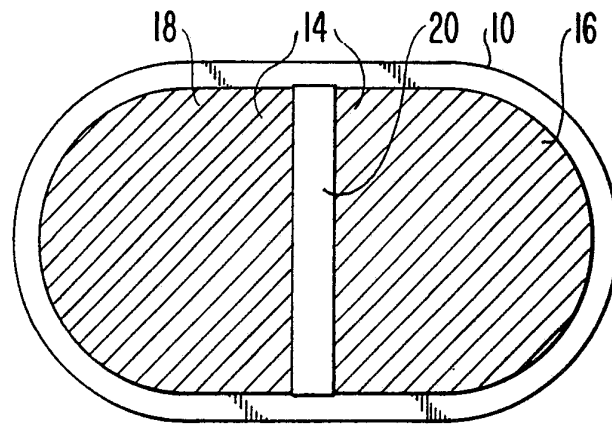

FIG. 3

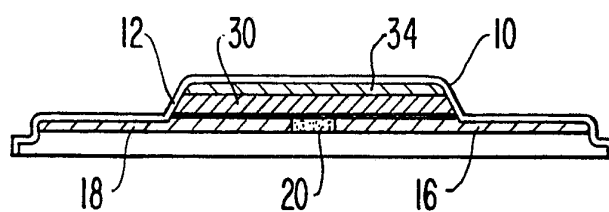

FIG. 4

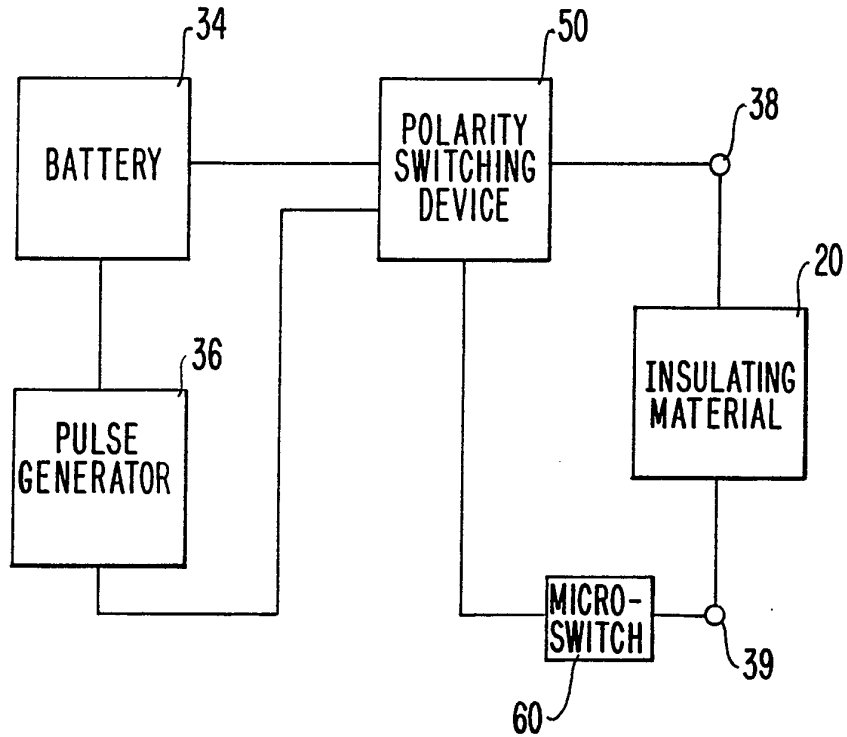

FIG. 5

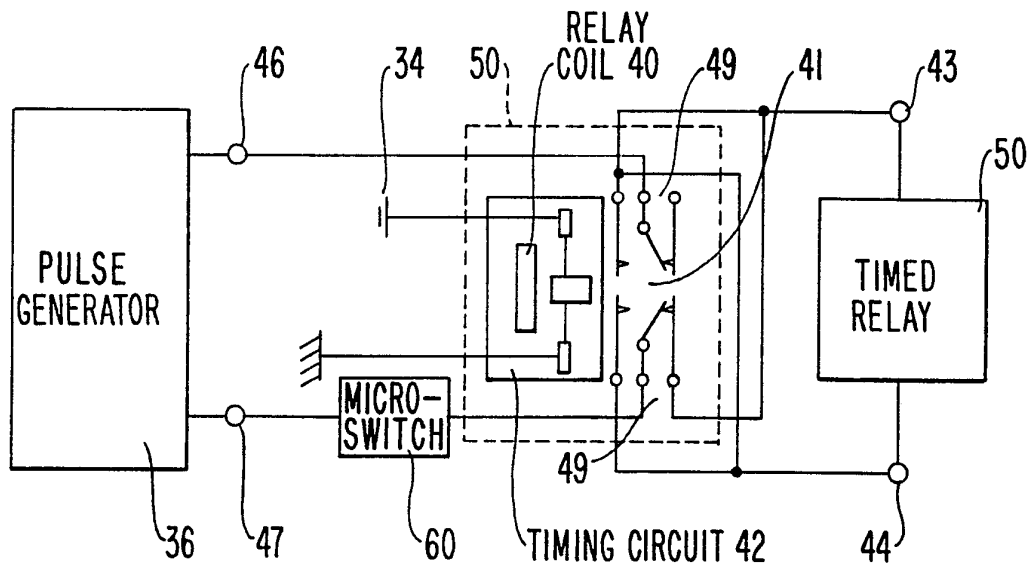

FIG. 6

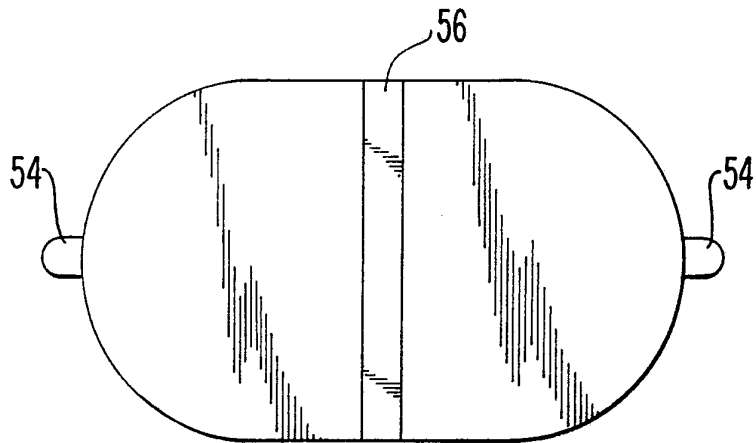

FIG. 7

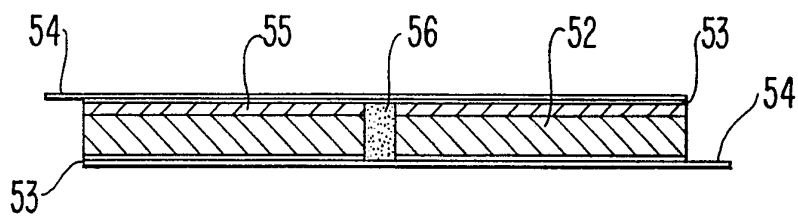

FIG. 8

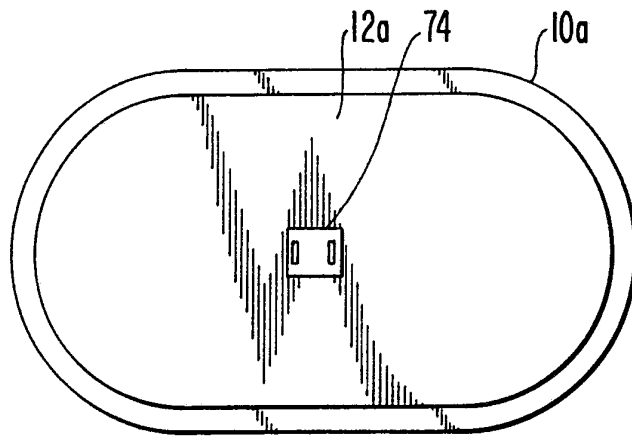
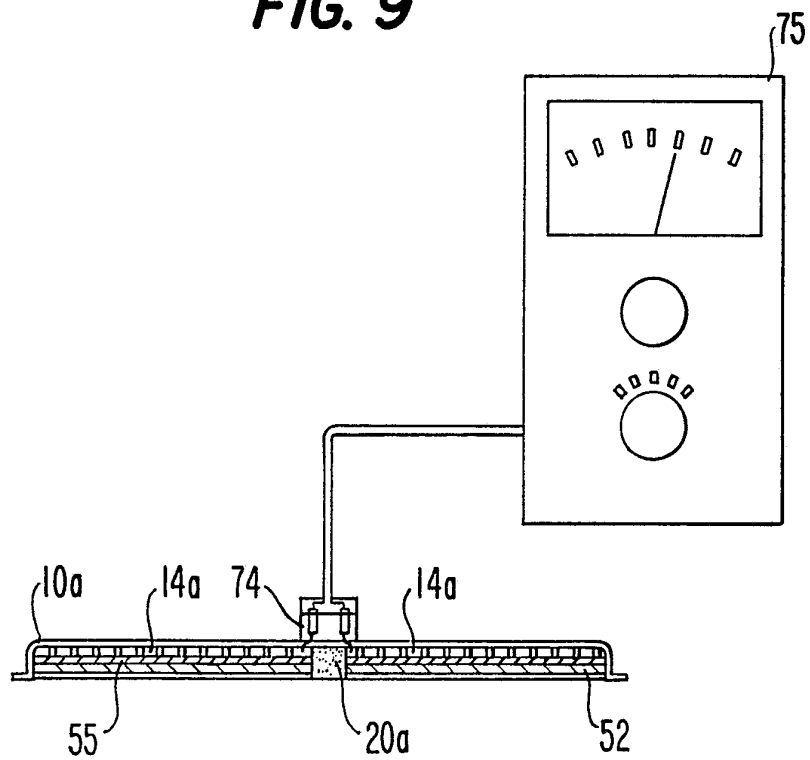

FIG. 9



INTERNATIONAL SEARCH REPORT

PCT/US 90/03015

International Application No

I. CLASSIFICATION OF SUBJECT MATTER (if several classification symbols apply, indicate all) ⁶		
According to International Patent Classification (IPC) or to both National Classification and IPC		
Int.Cl. 5	A61N1/30	
II. FIELDS SEARCHED		
Minimum Documentation Searched ⁷		
Classification System	Classification Symbols	
Int.Cl. 5	A61N	
Documentation Searched other than Minimum Documentation to the Extent that such Documents are Included in the Fields Searched ⁸		
III. DOCUMENTS CONSIDERED TO BE RELEVANT⁹		
Category ^o	Citation of Document, ¹¹ with indication, where appropriate, of the relevant passages ¹²	Relevant to Claim No. ¹³
Y	EP,A,0060452 (MEDTRONIC, INC) 22 September 1982 see page 6, line 27 - page 21, line 6; figures 1-11	1-3, 7, 8, 10, 11, 15, 16, 18
A	---	5, 6, 13, 14
Y	US,A,4927408 (ALZA CORPORATION) 22 May 1990 see the whole document	1-3, 7, 8, 10, 11, 15, 16, 18
A	---	4, 12, 17
A	WO,A,8607269 (DRUG DELIVERY SYSTEMS INC.) 18 December 1986 see page 19, line 20 - page 25, line 29; figures 12-17	1-8, 10-18

	-/--	
<p>^o Special categories of cited documents :¹⁰</p> <p>"A" document defining the general state of the art which is not considered to be of particular relevance</p> <p>"E" earlier document but published on or after the international filing date</p> <p>"L" document which may throw doubts on priority claim(s) or which is cited to establish the publication date of another citation or other special reason (as specified)</p> <p>"O" document referring to an oral disclosure, use, exhibition or other means</p> <p>"P" document published prior to the international filing date but later than the priority date claimed</p> <p>"T" later document published after the international filing date or priority date and not in conflict with the application but cited to understand the principle or theory underlying the invention</p> <p>"X" document of particular relevance; the claimed invention cannot be considered novel or cannot be considered to involve an inventive step</p> <p>"Y" document of particular relevance; the claimed invention cannot be considered to involve an inventive step when the document is combined with one or more other such documents, such combination being obvious to a person skilled in the art.</p> <p>"&" document member of the same patent family</p>		
IV. CERTIFICATION		
Date of the Actual Completion of the International Search	Date of Mailing of this International Search Report	
31 JANUARY 1991	20. 02. 91	
International Searching Authority	Signature of Authorized Officer	
EUROPEAN PATENT OFFICE	FERRIGNO A. <i>A Ferrigno</i>	

III. DOCUMENTS CONSIDERED TO BE RELEVANT (CONTINUED FROM THE SECOND SHEET)		
Category °	Citation of Document, with indication, where appropriate, of the relevant passages	Relevant to Claim No.
A	US,A,4764164 (M.SASAKI) 16 August 1988 see the whole document (cited in the application) ---	1-18

ANNEX TO THE INTERNATIONAL SEARCH REPORT
ON INTERNATIONAL PATENT APPLICATION NO. PCT/US 90/03015

SA 37435

This annex lists the patent family members relating to the patent documents cited in the above-mentioned international search report. The members are as contained in the European Patent Office EDP file on
The European Patent Office is in no way liable for these particulars which are merely given for the purpose of information. 31/01/91

Patent document cited in search report	Publication date	Patent family member(s)	Publication date
EP-A-0060452	22-09-82	US-H- H516	06-09-88
		US-A- 4406658	27-09-83
US-A-4927408	22-05-90	None	
WO-A-8607269	18-12-86	EP-A- 0225872	24-06-87
US-A-4764164	16-08-88	JP-A- 60188176	25-09-85
		JP-A- 61031169	13-02-86
		JP-A- 60156475	16-08-85
		AU-A- 1850688	22-09-88
		AU-B- 575068	21-07-88
		AU-A- 3249284	07-03-85
		CA-A- 1262564	31-10-89
		EP-A, B 0138347	24-04-85
		EP-A- 0308572	29-03-89
AU-B- 599493	19-07-90		