



(43) International Publication Date
28 November 2013 (28.11.2013)

- (51) International Patent Classification:
G03F 7/20 (2006.01)
- (21) International Application Number:
PCT/EP2013/059973
- (22) International Filing Date:
15 May 2013 (15.05.2013)
- (25) Filing Language: English
- (26) Publication Language: English
- (30) Priority Data:
10 2012 208 514.9 22 May 2012 (22.05.2012) DE
61/649 970 22 May 2012 (22.05.2012) US
- (71) Applicant: **CARL ZEISS SMT GMBH** [DE/DE];
Rudolf-Eber-Strasse 2, 73447 Oberkochen (DE).
- (72) Inventor: **SCHWAB, Markus**; Limesstrasse 47/2, 73434
Aalen (DE).
- (74) Agent: **RAU, SCHNECK & HÜBNER**; Königstrasse 2,
90402 Nürnberg (DE).
- (81) Designated States (unless otherwise indicated, for every
kind of national protection available): AE, AG, AL, AM,
AO, AT, AU, AZ, BA, BB, BG, BH, BN, BR, BW, BY,
BZ, CA, CH, CL, CN, CO, CR, CU, CZ, DE, DK, DM,
DO, DZ, EC, EE, EG, ES, FI, GB, GD, GE, GH, GM, GT,

HN, HR, HU, ID, IL, IN, IS, JP, KE, KG, KM, KN, KP,
KR, KZ, LA, LC, LK, LR, LS, LT, LU, LY, MA, MD,
ME, MG, MK, MN, MW, MX, MY, MZ, NA, NG, NI,
NO, NZ, OM, PA, PE, PG, PH, PL, PT, QA, RO, RS, RU,
RW, SC, SD, SE, SG, SK, SL, SM, ST, SV, SY, TH, TJ,
TM, TN, TR, TT, TZ, UA, UG, US, UZ, VC, VN, ZA,
ZM, ZW.

(84) Designated States (unless otherwise indicated, for every
kind of regional protection available): ARIPO (BW, GH,
GM, KE, LR, LS, MW, MZ, NA, RW, SD, SL, SZ, TZ,
UG, ZM, ZW), Eurasian (AM, AZ, BY, KG, KZ, RU, TJ,
TM), European (AL, AT, BE, BG, CH, CY, CZ, DE, DK,
EE, ES, FI, FR, GB, GR, HR, HU, IE, IS, IT, LT, LU, LV,
MC, MK, MT, NL, NO, PL, PT, RO, RS, SE, SI, SK, SM,
TR), OAPI (BF, BJ, CF, CG, CI, CM, GA, GN, GQ, GW,
ML, MR, NE, SN, TD, TG).

Declarations under Rule 4.17:

— of inventorship (Rule 4.17(iv))

Published:

- with international search report (Art. 21(3))
- before the expiration of the time limit for amending the
claims and to be republished in the event of receipt of
amendments (Rule 48.2(h))

[Continued on next page]

(54) Title: ADJUSTMENT DEVICE AND MASK INSPECTION DEVICE WITH SUCH AN ADJUSTMENT DEVICE

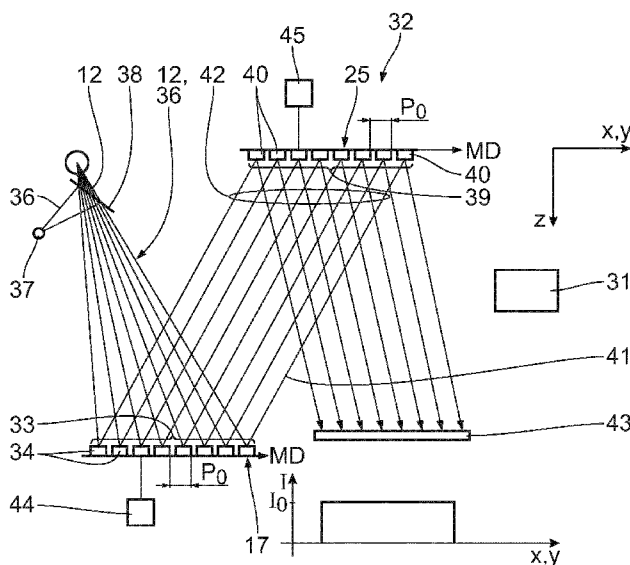

Fig. 5

(57) Abstract: An adjustment device (32) serves for
adjusting mirrors (17, 25) for guiding used radiation
(12) along a beam path. The adjustment device (32)
has at least a first adjustment mark (33) and at least
a second adjustment mark (39). At least one of the two
adjustment marks (33, 39) is fixedly connected to
one of the mirrors (17, 25) to be adjusted. The
relative position of the adjustment marks (33, 39)
with respect to one another is a measure for an
adjustment parameter for the correspondence between
an actual adjustment position of the mirrors (17, 25)
to be adjusted and an intended adjustment position.
The adjustment device (32) includes a spatially
resolving detector (43) for detecting the adjustment
parameter. At least one of the mirrors to be
adjusted is a facet mirror (17, 25) with a plurality
or multiplicity of mirror facets or mirror facet
groups. The result of this is an adjustment device
by means of which a predetermined adjustment
precision for the relative position of the two
mirrors with respect to one another is achieved.

WO 2013/174680 A3

(88) Date of publication of the international search report:
30 May 2014

INTERNATIONAL SEARCH REPORT

International application No
PCT/EP2013/059973

A. CLASSIFICATION OF SUBJECT MATTER
INV. G03F7/20
ADD.
According to International Patent Classification (IPC) or to both national classification and IPC

B. FIELDS SEARCHED
Minimum documentation searched (classification system followed by classification symbols)
G03F

Documentation searched other than minimum documentation to the extent that such documents are included in the fields searched

Electronic data base consulted during the international search (name of data base and, where practicable, search terms used)
EPO-Internal, WPI Data

C. DOCUMENTS CONSIDERED TO BE RELEVANT

Category*	Citation of document, with indication, where appropriate, of the relevant passages	Relevant to claim No.
X	DE 10 2009 043501 A1 (ZEISS CARL SMT GMBH [DE]) 31 March 2011 (2011-03-31) paragraphs [0007], [0011], [0020], [0021], [0055] - [0058] -----	1-4,8-13
X	EP 1 345 082 A1 (ASML NETHERLANDS BV [NL]) 17 September 2003 (2003-09-17) paragraphs [0031] - [0045]; figures 2,3 -----	1,2, 10-13
A	US 2011/188018 A1 (KLAASSEN MICHEL FRANSOIS HUBERT [NL] ET AL) 4 August 2011 (2011-08-04) paragraphs [0056], [0059], [0064]; figures 2,5c, 6, 8 -----	1-5,8-13
A	DE 10 2005 062038 A1 (ZEISS CARL SMT AG [DE]) 28 June 2007 (2007-06-28) paragraphs [0034] - [0046]; figure 2 -----	1-5,8-13

Further documents are listed in the continuation of Box C.

See patent family annex.

* Special categories of cited documents :

- "A" document defining the general state of the art which is not considered to be of particular relevance
- "E" earlier application or patent but published on or after the international filing date
- "L" document which may throw doubts on priority claim(s) or which is cited to establish the publication date of another citation or other special reason (as specified)
- "O" document referring to an oral disclosure, use, exhibition or other means
- "P" document published prior to the international filing date but later than the priority date claimed

- "T" later document published after the international filing date or priority date and not in conflict with the application but cited to understand the principle or theory underlying the invention
- "X" document of particular relevance; the claimed invention cannot be considered novel or cannot be considered to involve an inventive step when the document is taken alone
- "Y" document of particular relevance; the claimed invention cannot be considered to involve an inventive step when the document is combined with one or more other such documents, such combination being obvious to a person skilled in the art
- "&" document member of the same patent family

Date of the actual completion of the international search

25 October 2013

Date of mailing of the international search report

14/04/2014

Name and mailing address of the ISA/

European Patent Office, P.B. 5818 Patentlaan 2
NL - 2280 HV Rijswijk
Tel. (+31-70) 340-2040,
Fax: (+31-70) 340-3016

Authorized officer

Weckesser, Jens

INTERNATIONAL SEARCH REPORT

Information on patent family members

International application No PCT/EP2013/059973

Patent document cited in search report	Publication date	Patent family member(s)	Publication date
DE 102009043501 A1	31-03-2011	NONE	

EP 1345082 A1	17-09-2003	CN 1445612 A	01-10-2003
		EP 1345082 A1	17-09-2003
		JP 2004006823 A	08-01-2004
		SG 106138 A1	30-09-2004
		TW 583514 B	11-04-2004
		US 2003179357 A1	25-09-2003

US 2011188018 A1	04-08-2011	CN 102099744 A	15-06-2011
		JP 5377641 B2	25-12-2013
		JP 2011529629 A	08-12-2011
		KR 20110038714 A	14-04-2011
		NL 2003192 A1	02-02-2010
		TW 201013328 A	01-04-2010
		US 2011188018 A1	04-08-2011
		WO 2010012589 A1	04-02-2010

DE 102005062038 A1	28-06-2007	NONE	

INTERNATIONAL SEARCH REPORT

International application No.
PCT/EP2013/059973

Box No. II Observations where certain claims were found unsearchable (Continuation of item 2 of first sheet)

This international search report has not been established in respect of certain claims under Article 17(2)(a) for the following reasons:

1. Claims Nos.:
because they relate to subject matter not required to be searched by this Authority, namely:

2. Claims Nos.:
because they relate to parts of the international application that do not comply with the prescribed requirements to such an extent that no meaningful international search can be carried out, specifically:

3. Claims Nos.:
because they are dependent claims and are not drafted in accordance with the second and third sentences of Rule 6.4(a).

Box No. III Observations where unity of invention is lacking (Continuation of item 3 of first sheet)

This International Searching Authority found multiple inventions in this international application, as follows:

see additional sheet

1. As all required additional search fees were timely paid by the applicant, this international search report covers all searchable claims.

2. As all searchable claims could be searched without effort justifying an additional fees, this Authority did not invite payment of additional fees.

3. As only some of the required additional search fees were timely paid by the applicant, this international search report covers only those claims for which fees were paid, specifically claims Nos.:

4. No required additional search fees were timely paid by the applicant. Consequently, this international search report is restricted to the invention first mentioned in the claims; it is covered by claims Nos.:

1-5, 8-13

Remark on Protest

- The additional search fees were accompanied by the applicant's protest and, where applicable, the payment of a protest fee.
- The additional search fees were accompanied by the applicant's protest but the applicable protest fee was not paid within the time limit specified in the invitation.
- No protest accompanied the payment of additional search fees.

FURTHER INFORMATION CONTINUED FROM PCT/ISA/ 210

This International Searching Authority found multiple (groups of) inventions in this international application, as follows:

1. claims: 1-5, 8-13

Closest prior art: Document DE 10 2009 043 501 A1 (hereinafter D1) discloses the following features of claim 1, the references in parentheses applying to this document: Adjustment device for adjusting mirrors for guiding used radiation along a beam path (figure 6; par. 0055 - 0058) with at least a first adjustment mark (par. 0057 - 0058; partially reflecting element 611), with at least a second adjustment mark (par. 0057 - 0058; partially reflecting element 621), wherein at least one of the two adjustment marks is fixedly connected to one of the mirrors to be adjusted (par. 0056; mirrors 610, 620), wherein the relative position of the adjustment marks with respect to one another is a measure for an adjustment parameter for the correspondence between an actual adjustment position of the mirrors to be adjusted and an intended adjustment position (par. 0055), with a spatially resolving detector for detecting the adjustment parameter (par. 0056; interferometer 640 implicitly discloses a spatially resolving detector).

A person skilled in the art is aware of the high positioning accuracy required not only for the mirrors of an EUV projection system but also for the mirrors of an EUV illumination system. Therefore a person skilled in the art would without the exercise of an inventive step provide the facet mirrors of an EUV illumination system with adjustment devices according to D1, thereby arriving at the subject-matter of present claim 1 .

Special technical feature, taking due account of the description and drawings:

A periodicity of the adjustment markers on the mirrors to be adjusted differs, wherein the adjustment radiation partial beams extend in a divergent fashion with respect to one another or in a convergent fashion with respect to one another between the adjustment marks (claim 5 of the present application).

Technical effect of this special technical feature:

The adjustment device is particularly sensitive with respect to a distance maladjustment between the two mirrors.

Problem solved by this special technical feature:

How to achieve a high sensitivity with respect to a distance maladjustment between the two mirrors.

2. claims: 6, 7

Closest prior art: as for group 1

Special technical feature, taking due account of the description and drawings:

FURTHER INFORMATION CONTINUED FROM PCT/ISA/ 210

The first adjustment mark is imaged onto the second mark by the first and/or second mirror to be adjusted, wherein a distance between the image of the first adjustment mark and the second adjustment mark is detected as adjustment parameter.

Technical effect of this special technical feature:
The adjustment device is particularly sensitive with respect to translation maladjustment between the two mirrors.

Problem solved by this special technical feature:
How to achieve a high sensitivity with respect to a translation maladjustment between the two mirrors.
