



## INTERNATIONAL APPLICATION PUBLISHED UNDER THE PATENT COOPERATION TREATY (PCT)

<p>(51) International Patent Classification <sup>7</sup> : E21B 21/00, 4/02</p>	<p>A1</p>	<p>(11) International Publication Number: <b>WO 00/50731</b> (43) International Publication Date: 31 August 2000 (31.08.00)</p>
<p>(21) International Application Number: PCT/GB00/00642 (22) International Filing Date: 25 February 2000 (25.02.00) (30) Priority Data: 9904380.4 25 February 1999 (25.02.99) GB (71) Applicant (for all designated States except US): WEATHER-FORD/LAMB, INC. [US/US]; Suite 600, 515 Post Oak Boulevard, Houston, TX 77027 (US). (72) Inventor; and (75) Inventor/Applicant (for US only): MOYES, Peter, Barnes [GB/GB]; Lochnagar, The Terrace, Dunecht, Aberdeen AB32 7AX (GB). (74) Agent: HARDING, Richard, Patrick; Marks &amp; Clerk, 4220 Nash Court, Oxford Business Park South, Oxford OX4 2RU (GB).</p>		<p>(81) Designated States: AU, CA, GB, NO, US, European patent (AT, BE, CH, CY, DE, DK, ES, FI, FR, GB, GR, IE, IT, LU, MC, NL, PT, SE).  <b>Published</b> <i>With international search report. Before the expiration of the time limit for amending the claims and to be republished in the event of the receipt of amendments.</i></p>
<p>(54) Title: DRILLING METHOD</p>		
<p>(57) Abstract</p>		
<p>A drilling method in which a rotary drill bit is mounted on a tubular drillstring (32) extending through a bore comprises: drilling through a formation (33) containing fluid at a predetermined pressure; circulating drilling fluid down through the drill string (32) to exit the string at or adjacent the bit, and then upwards through an annulus (50) between the string and bore wall; and adding energy to the drilling fluid in the annulus at a location above the formation (33). The addition of energy to the fluid in the annulus (50) has the effect that the pressure of the drilling fluid above the formation (33) may be higher than the pressure of the drilling fluid in communication with the formation and that predetermined differential may be created between the pressure of the formation fluid and the pressure of the drilling fluid in communication with the formation.</p>		

**FOR THE PURPOSES OF INFORMATION ONLY**

Codes used to identify States party to the PCT on the front pages of pamphlets publishing international applications under the PCT.

AL	Albania	ES	Spain	LS	Lesotho	SI	Slovenia
AM	Armenia	FI	Finland	LT	Lithuania	SK	Slovakia
AT	Austria	FR	France	LU	Luxembourg	SN	Senegal
AU	Australia	GA	Gabon	LV	Latvia	SZ	Swaziland
AZ	Azerbaijan	GB	United Kingdom	MC	Monaco	TD	Chad
BA	Bosnia and Herzegovina	GE	Georgia	MD	Republic of Moldova	TG	Togo
BB	Barbados	GH	Ghana	MG	Madagascar	TJ	Tajikistan
BE	Belgium	GN	Guinea	MK	The former Yugoslav Republic of Macedonia	TM	Turkmenistan
BF	Burkina Faso	GR	Greece			TR	Turkey
BG	Bulgaria	HU	Hungary	ML	Mali	TT	Trinidad and Tobago
BJ	Benin	IE	Ireland	MN	Mongolia	UA	Ukraine
BR	Brazil	IL	Israel	MR	Mauritania	UG	Uganda
BY	Belarus	IS	Iceland	MW	Malawi	US	United States of America
CA	Canada	IT	Italy	MX	Mexico	UZ	Uzbekistan
CF	Central African Republic	JP	Japan	NE	Niger	VN	Viet Nam
CG	Congo	KE	Kenya	NL	Netherlands	YU	Yugoslavia
CH	Switzerland	KG	Kyrgyzstan	NO	Norway	ZW	Zimbabwe
CI	Côte d'Ivoire	KP	Democratic People's Republic of Korea	NZ	New Zealand		
CM	Cameroon			PL	Poland		
CN	China	KR	Republic of Korea	PT	Portugal		
CU	Cuba	KZ	Kazakstan	RO	Romania		
CZ	Czech Republic	LC	Saint Lucia	RU	Russian Federation		
DE	Germany	LI	Liechtenstein	SD	Sudan		
DK	Denmark	LK	Sri Lanka	SE	Sweden		
EE	Estonia	LR	Liberia	SG	Singapore		

DRILLING METHOD

The present invention relates to a drilling method, and to a drilling apparatus. Embodiments of the invention relate to a drilling method and apparatus where the effective circulating density (ECD) of drilling fluid (or drilling "mud") in communication with a hydrocarbon-bearing formation is lower than would be the case in a conventional drilling operation. The invention also relates to an apparatus for reducing the buildup of drill cuttings or other solids in a borehole during a drilling operation; and to a method of performing underbalance drilling.

When drilling boreholes for hydrocarbon extraction, it is common practice to circulate drilling fluid or "mud" downhole: drilling mud is pumped from surface down a tubular drillstring to the drill bit, where the mud leaves the drillstring through jetting ports and returns to surface via the annulus between the drillstring and the bore wall. The mud lubricates and cools the drill bit, supports the walls of the unlined bore, and carries dislodged rock particles or drill cuttings away from the drill bit and to the surface.

In recent years the deviation, depth and length of wells has increased, and during drilling the mud may be

circulated through a bore several kilometres long. Pressure losses are induced in the mud as it flows through the drillstring, downhole motors, jetting ports, and then passes back to the surface through the annulus and around stabilisers, centralisers and the like. This adds to natural friction associated pressure loss as experienced by any flowing fluid.

Similarly, the pressure of the drilling mud at the drill bit and, most importantly, around the hydrocarbon-bearing formation, has tended to rise as well depth, length and deviation increase; during circulation, the pressure across the formation is the sum of the hydrostatic pressure relating to the height and density of the column of mud above the formation, and the additional pressure required to overcome the flow resistance experienced as the mud returns to surface through the annulus. Of course the mud pressure at the bit must also be sufficient to ensure that the mud flowrate through the annulus maintains the entrainment of the drill cuttings.

The mud pressure in a bore is often expressed in terms of the effective circulating density (ECD), which is represented as the ratio between the weight or pressure of mud and the weight of a corresponding column of water. Thus, the hydrostatic pressure or ECD at a drill bit may be around 1.05SG, whereas during circulation the mud pressure,

or ECD, may be as high as 1.55SG.

It is now the case that the ECD of the drilling mud at the lower end of the bore where the bore intersects the hydrocarbon-bearing formations is placing a limit on the length and depth of bores which may be drilled and reservoirs accessed. In addition to mechanical considerations, such as top drive torque ratings and drill pipe strength, the increase in ECD at the formation may reach a level where the mud damages the formation, and in particular reduces the productivity of the formation.

During drilling it is usually preferred that the mud pressure is higher than the fluid pressure in the hydrocarbon-bearing formation, such that the formation fluid does not flow into the bore. However, if the pressure differential exceeds a certain level, known as the fracture gradient, the mud will fracture the formation and begin to flow into the formation. In addition to loss of drilling fluid, fracturing also affects the production capabilities of a formation. Attempts have been made to minimise the effects of fracturing by injecting materials and compounds into bore to plug the pores in the formation.

However, this increases drilling costs, is often of limited effectiveness, and tends to reduce the production capabilities of the formation.

High mud pressure also has a number of undesirable

effects on drilling efficiency. In deviated bores the drillstring may lie in contact with the bore wall, and if the bore intersects a lower pressure formation the fluid pressure acting on the remainder of the string will tend to push the string against the bore wall, significantly increasing drag on the string; this may result in what is known as "differential sticking".

It has also been suggested that high mud pressure at the bit reduces drilling efficiency, and this problem has been addressed in US Patents Nos. 4,049,066 (Richey) and 4,744,426 (Reed), the disclosures of which are incorporated herein by reference. Both documents disclose the provision of pump or fan arrangements in the annulus rearwardly of the bit, driven by mud passing through the drillstring, which reduces mud pressure at the bit. It is suggested that the disclosed arrangements improve jetting and the uplift of cuttings.

Another method of reducing the mud pressure at the bit is to improve drillstring design to minimise pressure losses in the annulus, and US Patent No. 4,823,891 (Hommani et al) discloses a stabiliser configuration which aims to minimise annulus pressure losses, and thus allow a desired mud flow to be achieved with lower initial mud pressure.

It is also known to aerate drilling mud, for example by addition of nitrogen gas, however the apparatus

necessary to implement this procedure is relatively expensive, cuttings suspension is poor, and the circulation of two phase fluids is problematic. The presence of low density gas in the mud may also make it difficult to "kill" a well in the event of an uncontrolled influx of hydrocarbon fluids into the wellbore.

It is among the objects of embodiments of the present invention to obviate or alleviate these and other difficulties associated with drilling operations.

According to the present invention there is provided a drilling method in which a drill bit is mounted on a tubular drill string extending through a bore, the method comprising:

drilling a bore which extends through a formation containing fluid at a predetermined pressure;

circulating drilling fluid down through the drill string to exit the string at or adjacent the bit, and then upwards through an annulus between the string and bore wall; and

adding energy to the drilling fluid in the annulus at a location above said formation such that the pressure of the drilling fluid above said location is higher than the pressure of the drilling fluid below said location and there is a predetermined differential between the pressure of the formation fluid and the pressure of the drilling

fluid in communication with the formation.

The invention also relates to apparatus for use in implementing this method.

The method of the present invention allows the pressure of the drilling fluid in communication with the formation, typically a hydrocarbon-bearing formation, to be maintained at a relatively low level, even in relatively deep or highly deviated bores, while the pressure in the drilling fluid above the formation may be maintained at a higher level to facilitate drilling fluid circulation and cuttings entrainment.

The differential between the drilling fluid pressure and the formation fluid pressure, which is likely to have been determined by earlier surveys, may be selected such that the drilling fluid pressure is high enough to prevent the formation fluid from flowing into the bore, but is not so high as to fracture or otherwise damage the formation.

In certain embodiments, the pressure differential may be varied during a drilling operation to accommodate different conditions, for example the initial pressure differential may be controlled to assist in formation of a suitable filter cake. Alternatively, the drilling fluid pressure may be selected to be lower than the formation fluid pressure, that is the invention may be utilised to carry out "underbalance" drilling; in this case the returning



drilling fluid may carry formation fluid, which may be separated from the drilling fluid at surface.

Preferably, energy is added to the drilling fluid by at least one pump or fan arrangement. Most preferably, the pump is driven by the fluid flowing down through the drillstring, such as in the arrangements disclosed in US Patents Nos. 4,049,066 and 4,744,426. Fluid driven downhole pumps are also produced by Weir Pumps Limited of Cathcart, Glasgow, United Kingdom. The preferred pump form utilises a turbine drive, that is the fluid is directed through nozzles onto turbine blades which are rotated to drive a suitable impeller acting on the fluid in the annulus. Such a turbine drive is available, under the TurboMac trade mark, from Rotech of Aberdeen, United Kingdom. When using the preferred pump form the initial pump pressure at surface will be relatively high, as energy is taken from the fluid, as it flows down through the string, to drive the pump. Alternatively, in other embodiments it may be possible for the pump to be driven by a downhole motor, to be electrically powered, or indeed driven by any suitable means, such as from the rotation of the drillstring.

Energy may be added to the drilling fluid in the annulus at a location adjacent the drill bit, but is more likely to be added at a location spaced from the drill bit,

to allow the bore to be drilled through the formation and still ensure that the higher pressure fluid above said location is spaced from the formation.

In one embodiment of the invention, a proportion of the circulating drilling fluid may be permitted to flow directly from the drillstring bore to the annulus above the formation, and such diversion of flow may be particularly useful in boreholes of varying diameter, the changes in diameter typically being step increases in bore diameter. When the bore diameter increases, drilling fluid flow speed in the annulus will normally decrease, and the additional volume of fluid flowing directly from the drillstring bore into the annulus assists in maintaining flow speed and cuttings entrainment. This may be achieved by provision of one or more bypass subs in the string. The bypass subs may be selectively operable to provide fluid bypass only when considered necessary or desirable.

The drill string may also incorporate means for isolating sections of one or both of the drill string bore and annulus when there is no fluid circulation. This is of particular importance when the pressure of the circulating drilling fluid at the formation is lower than hydrostatic pressure; the isolating means will support the column of fluid above the formation, allowing lower sections of the bore to be maintained at relatively low pressures.

Alternatively, or in addition, the isolating means may serve to prevent fluid flowing from the formation and then up the bore in underbalance conditions. The isolating means may be in the form of one or more valves, packers, swab cups or the like.

The drillstring may also be provided with means for agitating cuttings in the annulus, such as the flails disclosed in US Patent No. 5,651,420 (Tibbets et al), the disclosure of which is incorporated herein by reference.

Tibbets et al propose mounting flails on elements of the drillstring, which flails are actuated by the rotation of the string or the flow of drilling fluid around the flails.

Most preferably however, the agitating means are mounted on a body which is rotatable relative to the string. The body is preferably driven to rotate by drive means actuated by the flow of drilling fluid through the string, but may be driven by other means. This feature may be provided in combination with or separately of the main aspect of the invention.

These and other aspects of the present invention will now be described, by way of example only, with reference to the accompanying drawings, in which:

Figure 1 is a schematic illustration of a conventional wellbore drilling operation;

Figure 2 is a graph illustrating the pressure of

circulating drilling mud at various points in the wellbore of Figure 1;

Figure 3 is a schematic illustration of a wellbore drilling operation according to an embodiment of the present invention;

Figure 4 is an enlarged sectional view of a pump arrangement of Figure 3; and

Figure 5 is a graph illustrating the pressure of circulating drilling mud at various points in the wellbore in a drilling operation according to an embodiment of the present invention.

Reference is first made to Figure 1 of the drawings, which illustrates a conventional drilling operation. A rotating drill string 12 extends through a borehole 14, and drilling mud is pumped from the surface down the drill string 12, to exit the string via jetting ports in a drill bit 16, and returns to the surface via the annulus 17 between the string 14 and the bore hole wall.

Reference is now also made to Figure 2 of the drawings, which is a sketch graph of the pressure of the drilling mud at various points in the wellbore 14 as illustrated in Figure 1. The mud enters the drillstring at surface at a relatively high pressure  $P_1$ , and emerges from the bit 16 at a lower pressure  $P_2$ , reflecting the pressure losses resulting from the passage of the mud through the

string 12 and bit 16. The drilling mud returns to the surface via the annulus 17 and reaches surface at close to atmospheric pressure  $P_3$ .

Figure 3 of the drawings illustrates a drilling operation in accordance with an embodiment of a first aspect of the present invention, a drill string 32 being shown located in a drilled bore intersecting a hydrocarbon-bearing formation 33.

Mounted on the drillstring 32 are two pump assemblies 34, 36 which serve to assist the flow of drilling mud through the annulus, and to allow a reduction in the ECD at various points in the wellbore, with the lowermost pump 36 being located above the formation 33. One of the pumps 34 is shown schematically in Figure 4 of the drawings, and comprises a turbine motor section 46, such as is available under the TurboMac trade mark from Rotech of Aberdeen, United Kingdom, and a pump section 48. The motor section 46 is arranged to be driven by the flow of mud downhole through the string bore 44, rotation of the motor section 46 being transferred to the pump section 48, which includes vanes 49 extending into the annulus 50. The pump vanes are arranged to add energy to the mud in the annulus 50, increasing the mud pressure as it passes across the pump section 48.

Figure 5 is a sketch graph of the pressure of

circulating drilling mud in a drilling operation utilising a single pump assembly 36 as described in Figure 4, the pump 36 being located in the string such that the pump 36 remains above the hydrocarbon-bearing formation during the drilling operation. The solid line is the same as that of the graph of Figure 2, and illustrates the circulating mud pressure profile in a comparable conventional wellbore drilling operation. The dashed line illustrates the effect on the circulating mud pressure resulting from the provision of a pump assembly 36 in the drillstring, as will be described. At surface, the mud pressure must be higher than conventional, shown by point 52, and then drops gradually due to pressure losses to point 54, where the fluid in the drill string passes through the pump turbine motor section 46 and transfers energy to the fluid in the annulus 50, as reflected by the rapid loss of pressure, to point 56. As the mud emerges from the drillstring at the drill bit, it is apparent that the pressure or ECD of the mud, at point 58, is lower than would be the case in a conventional drilling operation, despite the higher initial mud pressure 52. As the return mud passes up through the annulus 50 it loses pressure gradually until reaching the pump 36, at point 60, whereupon it receives an energy input in the form of a pressure boost 62, to ensure that the mud will flow to the surface with the cuttings entrained in the

mud flow. As with a conventional drilling operation, the mud exits the string at close to atmospheric pressure, at point 64.

The pressure of the fluid in the formation 33 will have been determined previously by surveys, and the location of the pump 36 and the mud pressure between the points 58, 60 is selected such that there is a predetermined pressure differential between the drilling fluid pressure and the formation fluid pressure. In most circumstances, the drilling fluid pressure will be selected to be higher than the formation fluid pressure, to prevent or minimise the flow of formation fluid into the bore, but not so high to cause formation damage, that is at least below the fracture gradient.

Thus, it may be seen that the present invention provides a means whereby the ECD in the section of wellbore intersecting the hydrocarbon-bearing formation may be effectively reduced or controlled to provide a predetermined pressure between the drilling fluid and the formation fluid without the need to reduce the mud pressure elsewhere in the wellbore or impact on cuttings entrainment. This ability to reduce and control the ECD of the drilling mud in communication with the hydrocarbon-bearing formation allows drilling of deeper and longer wells while reducing or obviating the occurrence of

formation damage, and will reduce or obviate the need for formation pore plugging materials, thus reducing drilling costs and improving formation production.

It will be understood that the foregoing description is for illustrative purposes only, and that various modifications and improvements may be made to the apparatus and method herein described, without departing from the scope of the invention. For example, the pump assemblies may be electrically or hydraulically powered, and may only be actuated when the pressure of the drilling mud in communication with the formation rises above a predetermined pressure; a predetermined detected pressure may activate a fluid bypass causing fluid to be directed to drive an appropriate pump assembly.



CLAIMS

1. A drilling method in which a drill bit is mounted on a tubular drill string extending through a bore, the method comprising:

drilling a bore extending through a formation containing fluid at a predetermined pressure;

circulating drilling fluid down through the drill string to exit the string at or adjacent the lower end thereof, and then pass upwards through an annulus between the string and bore wall; and

adding energy to the drilling fluid in the annulus at a location above said formation such that the pressure of the drilling fluid above said location is higher than the pressure of the drilling fluid below said location and there is a predetermined differential between the pressure of the formation fluid and the pressure of the drilling fluid in communication with the formation.

2. The method of claim 1, wherein the differential between the drilling fluid pressure and the formation fluid pressure is selected such that the drilling fluid pressure is high enough to prevent the formation fluid from flowing

into the bore, but is not so high as to damage the formation.

3. The method of claim 1 or 2, wherein the pressure of the drilling fluid above said location is higher than the pressure of the drilling fluid in communication with the formation.

4. The method of claim 1, wherein the drilling fluid pressure at the formation is lower than the formation fluid pressure.

5. The method of any of claims 1, 2, 3 or 4, wherein the formation is a hydrocarbon-bearing formation.

6. The method of any of the preceding claims, wherein the pressure of the fluid in the formation is determined by prior survey.

7. The method of any of claims 1 to 6, wherein energy is added to the drilling fluid at said location by at least one pump arrangement.

8. The method of claim 7, wherein the pump is driven by the fluid flowing through the drillstring.

9. The method of claim 7, wherein the pump is electrically powered.

10. The method of claim 7, wherein the pump is driven by the rotation of the drill string.

11. The method of any of the preceding claims, wherein a proportion of the circulating drilling fluid flows directly from the drill string bore to the annulus above said location.

12. The method of any of the preceding claims, further comprising isolating sections at least one of the drill string bore and annulus when there is no fluid circulation, such that such sections may be maintained at relatively low pressures.

13. The method of any of the preceding claims, wherein the pressure of the circulating drilling fluid at the formation is lower than hydrostatic pressure.

14. The method of any of the preceding claims, further comprising agitating drill cuttings in the annulus.

15. The method of claim 14, wherein the drill cuttings are

agitated by agitating members driven by the flow of drilling fluid through the string.

16. Drilling apparatus for accessing a sub-surface formation containing fluid at a predetermined pressure, the apparatus comprising:

a drill bit mounted on a tubular drill string for extending through a bore and drilling through a formation containing fluid at a predetermined pressure;

means for circulating drilling fluid down through the drill string to exit the string at or adjacent the bit, and then upwards through an annulus between the string and bore wall; and

means for adding energy to the drilling fluid in the annulus above the formation such that the pressure of the drilling fluid above said means is higher than the pressure of the drilling fluid below said means and there is a predetermined differential between the pressure of the formation fluid and the pressure of the drilling fluid in communication with the formation.

17. The apparatus of claim 16, wherein said means for adding energy is at least one pump arrangement mounted on the drill string.

18. The apparatus of claim 17, wherein the pump is adapted to be driven by the fluid flowing through the drill string.

19. The apparatus of claim 18, wherein the pump comprises a turbine drive.

20. The apparatus of claim 17, wherein the pump is an electrically driven pump.

21. The apparatus of claim 17, wherein the pump is adapted to be driven by rotation of the drillstring.

22. The apparatus of any of claims 16 to 21, wherein the drillstring includes means for directing a proportion of the circulating drilling fluid directly from the drillstring bore to the annulus above said energy adding means.

23. The apparatus of claim 22, wherein said means for directing a proportion of the circulating drilling fluid directly from the drillstring bore to the annulus above said energy adding means is a bypass tool.

24. The apparatus of any of claims 16 to 23, further comprising means for isolating sections of at least one of

the drillstring bore and annulus when there is no fluid circulation.

25. The apparatus of claim 25, wherein the isolating means comprises at least one valve.

26. The apparatus of any of claims 16 to 25, further comprising means for agitating cuttings in the annulus.

27. The apparatus of claim 26, wherein the agitating means is mounted on a body which is rotatable relative to the drillstring and is driven to rotate by the flow of drilling fluid through the string.

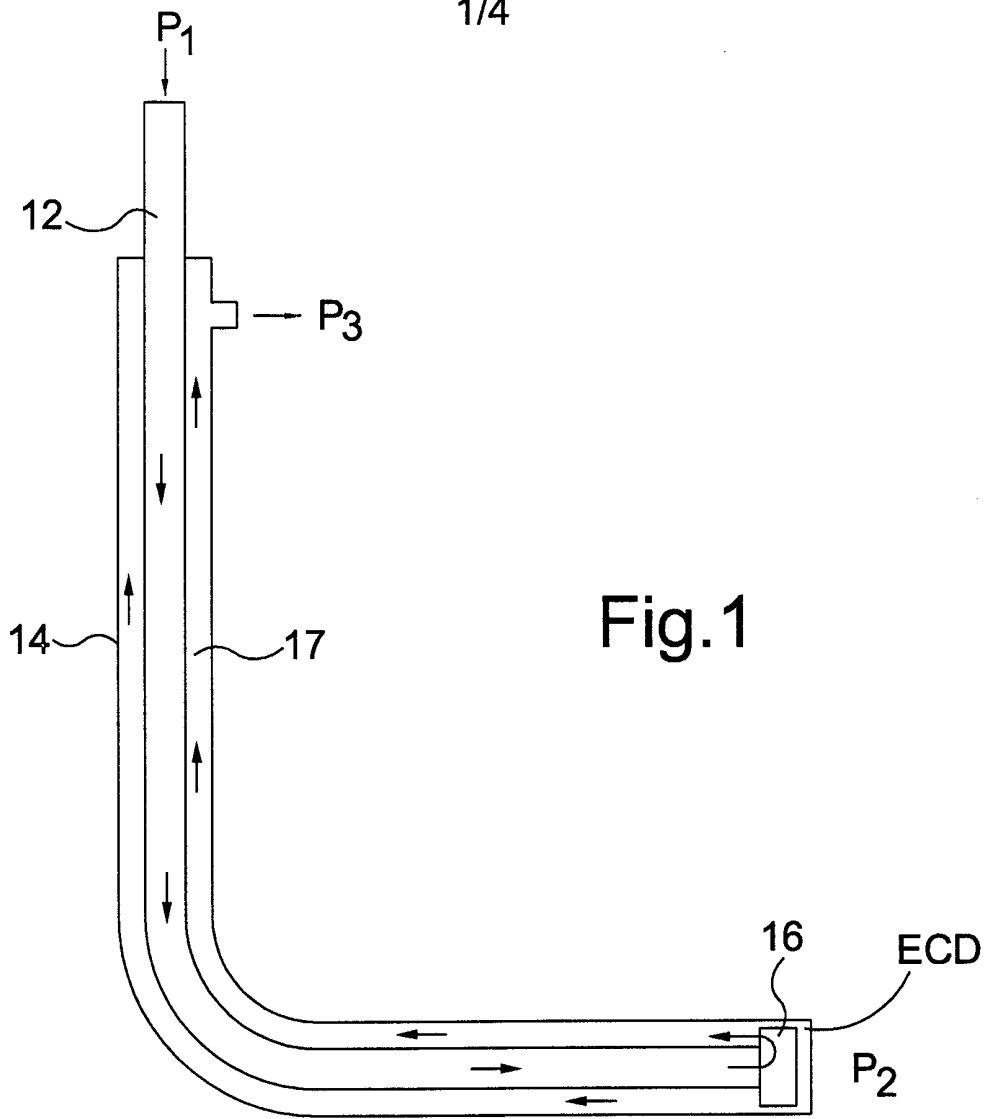

Fig.1

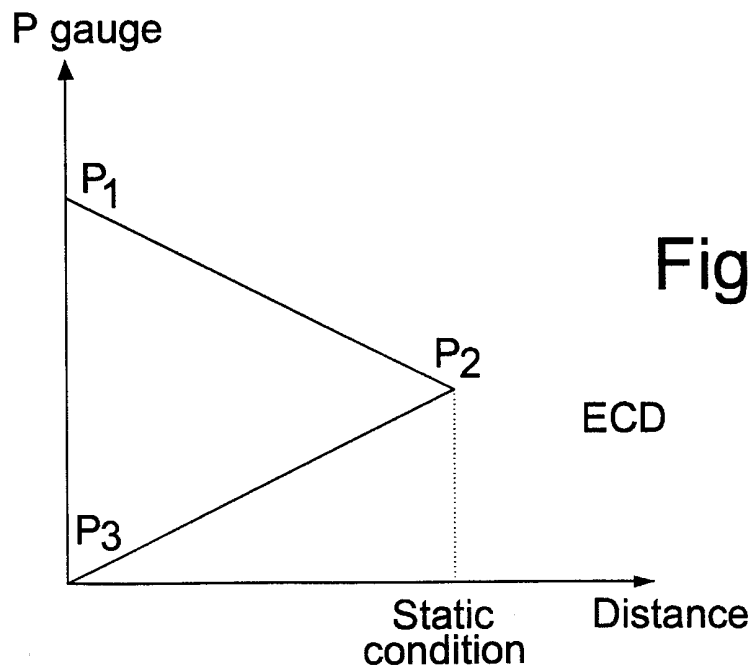

Fig.2

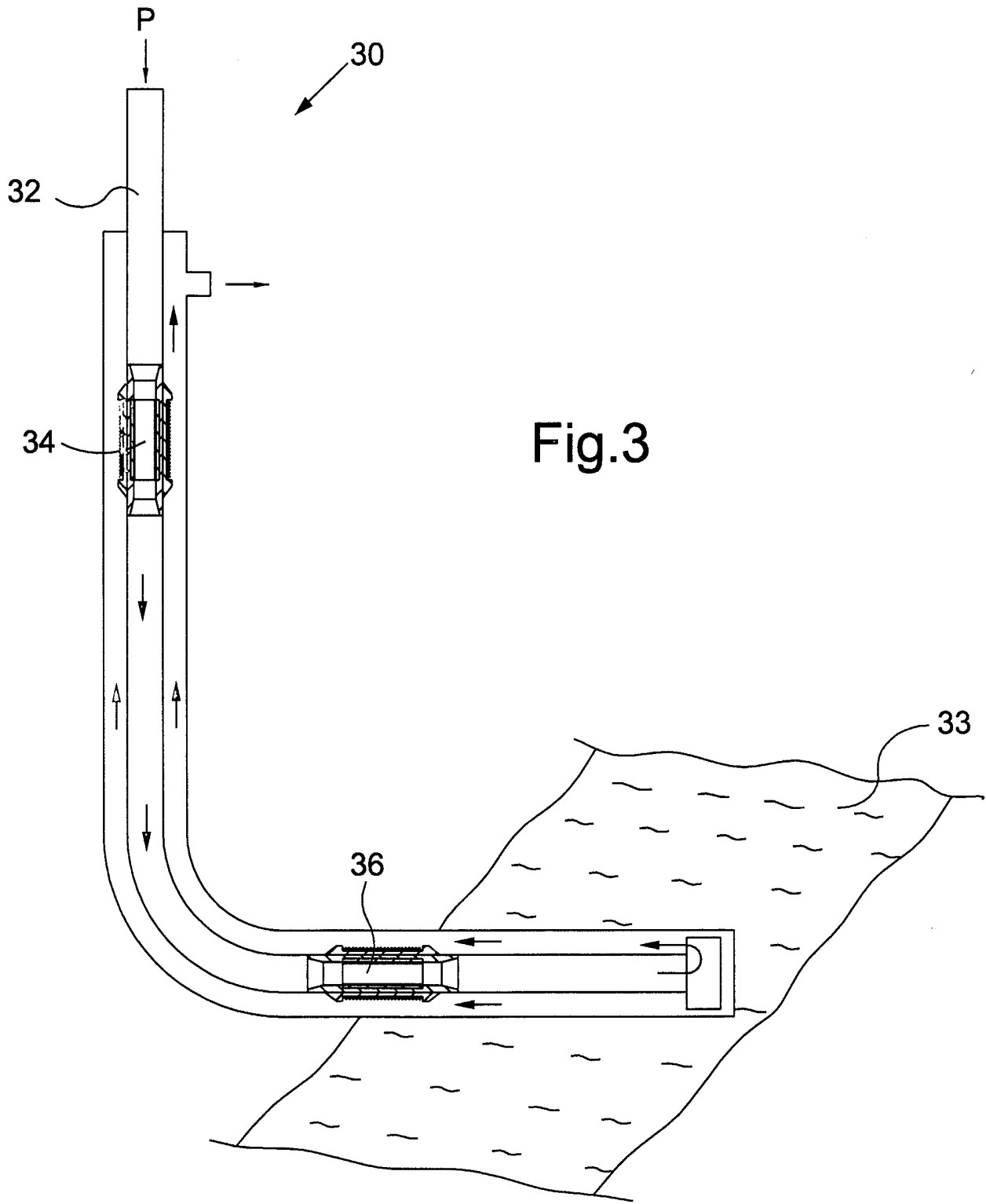

Fig.3



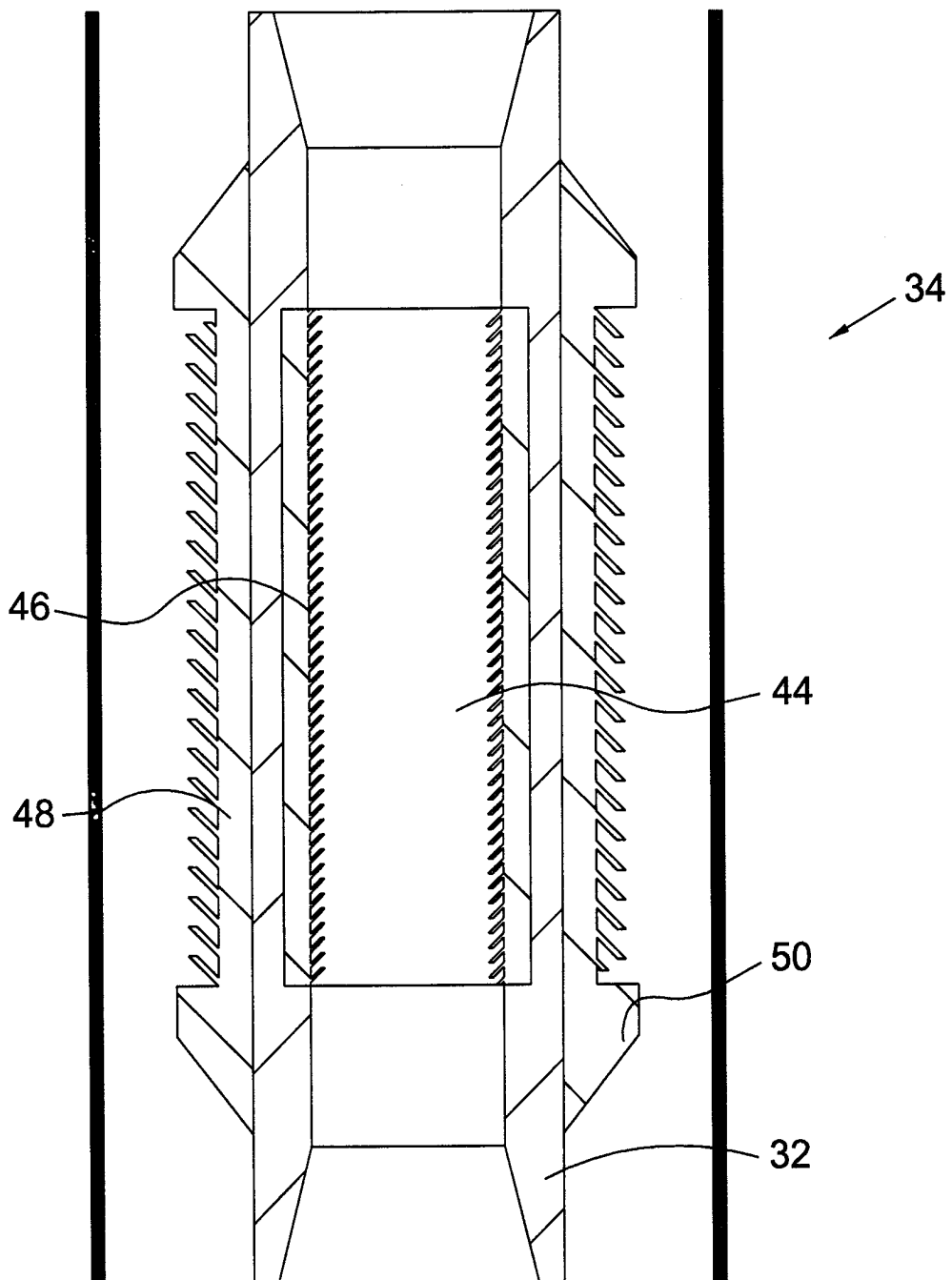

Fig.4

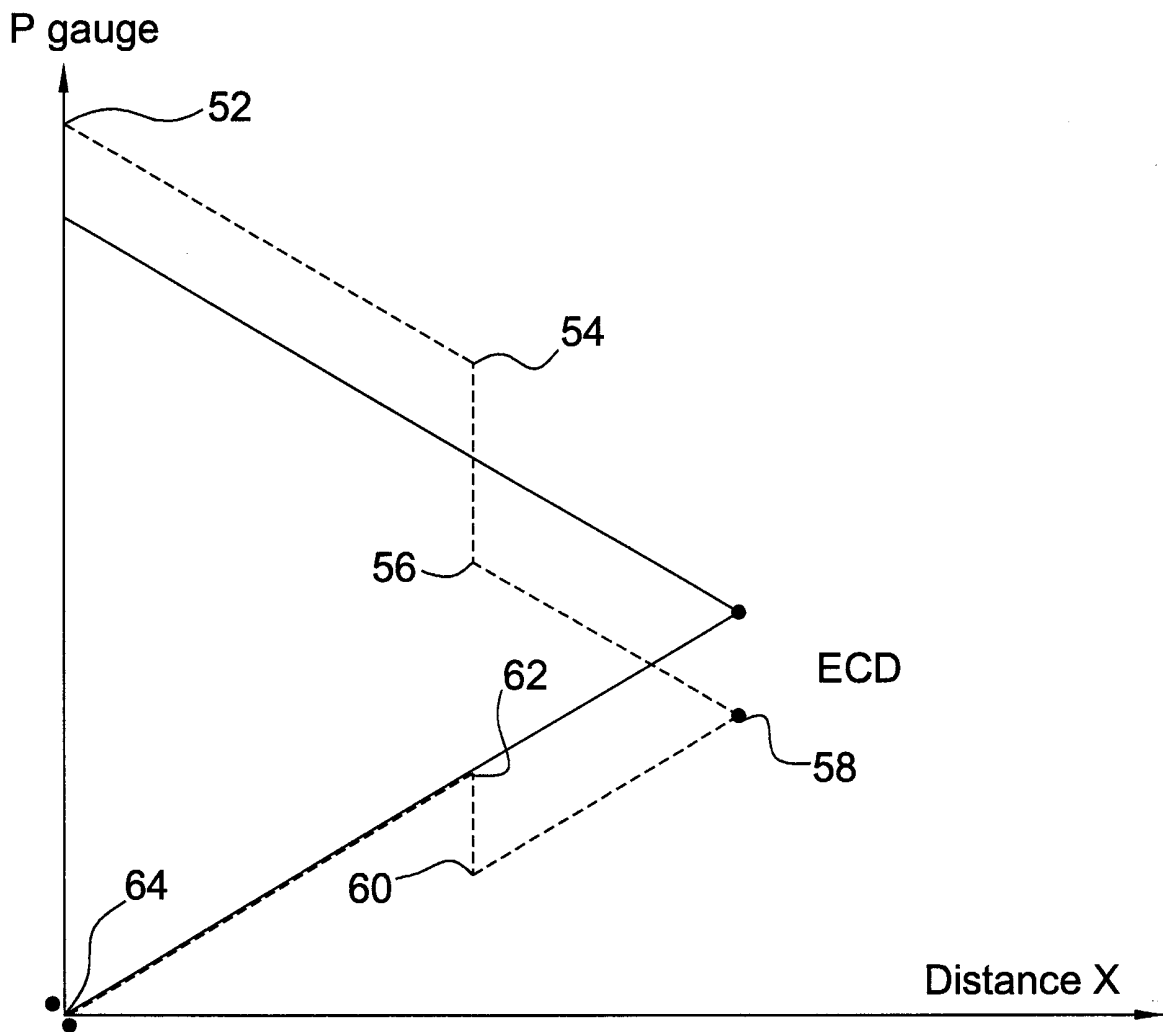

Fig.5

# INTERNATIONAL SEARCH REPORT

Intern. Application No

PCT/GB 00/00642

**A. CLASSIFICATION OF SUBJECT MATTER**  
 IPC 7 E21B21/00 E21B4/02

According to International Patent Classification (IPC) or to both national classification and IPC

**B. FIELDS SEARCHED**

Minimum documentation searched (classification system followed by classification symbols)  
 IPC 7 E21B

Documentation searched other than minimum documentation to the extent that such documents are included in the fields searched

Electronic data base consulted during the international search (name of data base and, where practical, search terms used)

**C. DOCUMENTS CONSIDERED TO BE RELEVANT**

Category °	Citation of document, with indication, where appropriate, of the relevant passages	Relevant to claim No.
A	US 4 630 691 A (HOOPER DAVID W) 23 December 1986 (1986-12-23) ---	1,7,16, 17
A	US 5 339 899 A (RAVI KRIS M ET AL) 23 August 1994 (1994-08-23) claims ---	1,16
A	US 4 430 892 A (OWINGS ALLEN J) 14 February 1984 (1984-02-14) claims ---	1,16
A	US 5 651 420 A (TIBBITTS GORDON A ET AL) 29 July 1997 (1997-07-29) cited in the application abstract ---	26
A	US 3 583 500 A (RANDALL BILLY V ET AL) 8 June 1971 (1971-06-08) -----	

Further documents are listed in the continuation of box C.       Patent family members are listed in annex.

° Special categories of cited documents :

<p>"A" document defining the general state of the art which is not considered to be of particular relevance</p> <p>"E" earlier document but published on or after the international filing date</p> <p>"L" document which may throw doubts on priority claim(s) or which is cited to establish the publication date of another citation or other special reason (as specified)</p> <p>"O" document referring to an oral disclosure, use, exhibition or other means</p> <p>"P" document published prior to the international filing date but later than the priority date claimed</p>	<p>"T" later document published after the international filing date or priority date and not in conflict with the application but cited to understand the principle or theory underlying the invention</p> <p>"X" document of particular relevance; the claimed invention cannot be considered novel or cannot be considered to involve an inventive step when the document is taken alone</p> <p>"Y" document of particular relevance; the claimed invention cannot be considered to involve an inventive step when the document is combined with one or more other such documents, such combination being obvious to a person skilled in the art.</p> <p>"&amp;" document member of the same patent family</p>
--	--

Date of the actual completion of the international search  <b>9 June 2000</b>	Date of mailing of the international search report  <b>19/06/2000</b>
---	---

Name and mailing address of the ISA European Patent Office, P.B. 5818 Patentlaan 2 NL - 2280 HV Rijswijk Tel. (+31-70) 340-2040, Tx. 31 651 epo nl, Fax: (+31-70) 340-3016	Authorized officer  <b>Fonseca Fernandez, H</b>
--	---

# INTERNATIONAL SEARCH REPORT

Information on patent family members

International Application No

PCT/GB 00/00642

Patent document cited in search report	A	Publication date	Patent family member(s)	Publication date
US 4630691	A	23-12-1986	NONE	
US 5339899	A	23-08-1994	NONE	
US 4430892	A	14-02-1984	NONE	
US 5651420	A	29-07-1997	GB 2298881 A, B	18-09-1996
			GB 2330607 A, B	28-04-1999
			GB 2330608 A, B	28-04-1999
			GB 2330609 A, B	28-04-1999
			US 5901797 A	11-05-1999
US 3583500	A	08-06-1971	NONE	