

(No Model.)

T. GRABOWSKI & K. JURKOWSKI.
PADLOCK.

No. 577,246.

Patented Feb. 16, 1897.

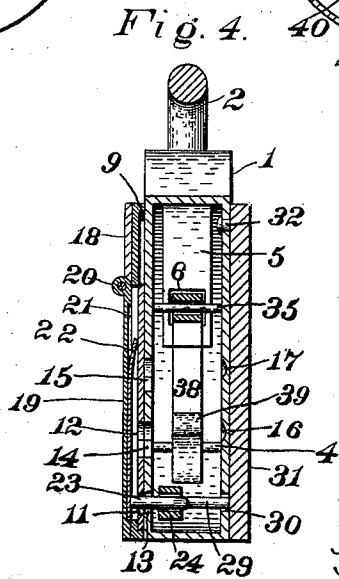
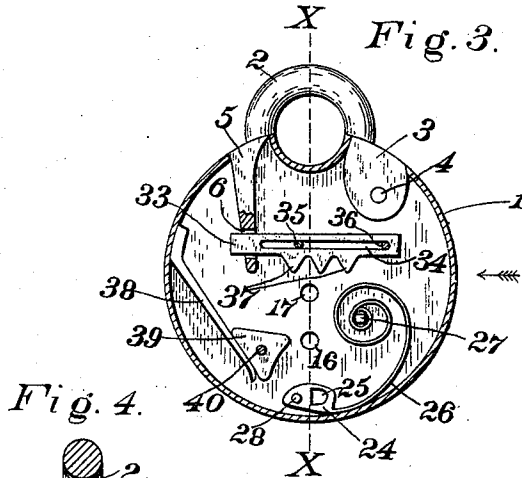
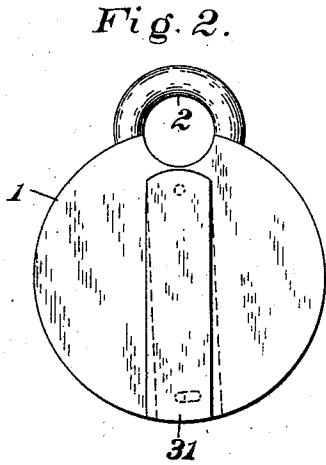
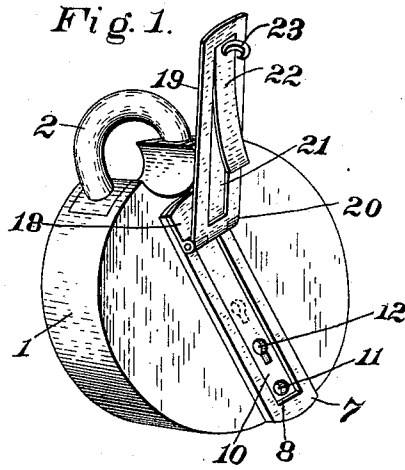

Witnesses:
James Smith.
R. Clinton Bahner.

Inventors:
Theodor Grabowski,
Kazimierz Jurkowski,
By Edwin Guthrie, Attorney

UNITED STATES PATENT OFFICE.

THEODOR GRABOWSKI, OF BUFFALO, AND KAZIMIERZ JURKOWSKI, OF
NIAGARA FALLS, NEW YORK.

PADLOCK.

SPECIFICATION forming part of Letters Patent No. 577,246, dated February 16, 1897.

Application filed September 5, 1896. Serial No. 604,967. (No model.)

To all whom it may concern:

Be it known that we, THEODOR GRABOWSKI, a citizen of the United States, residing at Buffalo, in the county of Erie, and KAZIMIERZ JURKOWSKI, a subject of the Emperor of Russia, residing at Niagara Falls, in the county of Niagara, State of New York, have invented certain new and useful Improvements in Padlocks; and we do declare the following to be a full, clear, and exact description of the invention, such as will enable others skilled in the art to which it appertains to make and use the same, reference being had to the accompanying drawings, and to the figures of reference marked thereon, which form a part of this specification.

Our invention relates to padlocks, more particularly to padlocks which add to the security and usefulness of the ordinary padlock by disguising the entrance to the keyhole.

The object of our invention is to provide a padlock simple in operation and durable and cheap with regard to construction, into the keyhole of which the key cannot be inserted until a preliminary manipulation of certain parts is completed and the true keyhole disclosed.

It is a further object of our invention to effectually conceal from close scrutiny the method of instituting the series of movements by which the parts masking the keyhole are so actuated as to expose it. Until the operator has learned the method of gaining access to the keyhole the possession of the key affords no aid in unfastening the padlock.

Each constituent element of our invention is described in detail, and its office, together with the mode of operation of the whole, fully explained hereinafter.

Referring to the accompanying drawings, wherein like numerals are employed to designate like parts throughout, Figure 1 represents a perspective view of our invention from the front, showing the keyhole-cover raised and exhibiting the attachments thereto. Fig. 2 represents a view of the back of our invention. Fig. 3 represents a vertical mid-section view of the casing, looking toward the back, and presenting the interior details of the lock. Fig. 4 represents, upon a somewhat enlarged

scale, a vertical mid-sectional view of the entire lock, the cut being made upon a line indicated by X X in Fig. 3, the observer looking in the direction of the arrow shown at the right of that figure.

In each view numeral 1 designates the casing, of any convenient shape, and, as customarily constructed, no joints appear except where the bow 2 enters the casing.

Considering Fig. 3, numeral 3 marks a flat portion of bow 2, and 4 a pivot upon which the entire bow is oscillative.

5 designates a projecting tongue of the bow, through the lower end of which is formed a slot 6, designed to admit the bolt of the lock, as hereinafter set out.

In Figs. 1 and 4 numeral 7 designates the keyhole guard-plate fixed vertically upon the front face of casing 1. A slot 8 extends longitudinally through the plate, and a recess 9 is formed in its under side to accommodate a sliding keyhole-plate 10. Plate 10 is less in length than recess 9 and is capable of being moved lengthwise therein. Two orifices pierce plate 10, one near its lower extremity (marked 11) and one in the form of a keyhole (marked 12) situated at some distance above the first mentioned.

Through the front face of casing 1 is an orifice 13, similar to and placed to register with orifice 11 in plate 10. In the normal position of sliding plate 10 keyhole 12 registers with keyhole 14 of the casing, and a second keyhole 15 is cut through the casing at such a distance from the first keyhole 14, regard being had to the extent of the sliding movement of plate 10, as will enable the keyhole 13 to be caused to register with the second keyhole through the casing 1.

16 and 17 designate depressions in the inner surface of the back of the casing, in which the end of a key inserted either through keyhole 14 or 15 may be supported while being turned.

Number 18 marks the portion of the keyhole-cover which is fixed upon and coincides with the upper portion of keyhole guard-plate 7. The remainder of the keyhole-cover 19 is hinged to the fixed portion by hinge 20. A recess 21 is formed in the under surface of the hinged cover 19, and one end of a flat

curved spring 22 is fixed in the outer end of the recess. The free end of spring 22 rises out of the recess. At the same point there is fixed a pin-hook 23, which projects perpendicularly from the lower face of hinged cover 19. The parts just described are best shown in Fig. 1, and they also appear in Fig. 4. Hinged cover 19, when closed, is exactly coextensive with the lower or slotted portion of plate 7.

Number 24, Fig. 3, marks a block having a slot 25 and constituting one end (the free end) of a spiral spring 26, the remaining end of which is bent about a square stud 27, projecting from the inner surface of the back of the casing. Slot 25 of block 24 possesses one edge formed to engage hook-pin 23 when hinged cover 19 is closed against the force of curved spring 22.

Number 28 marks the end of a pin 29, (see also Fig. 4,) which passes through a slot 30 in the back of the casing and is driven into the under face of a plate 31, which plate is arranged to rest closely against the outer surface of the back of the casing and to swing, under the limitations imposed by slot 30, upon the pivot-pin 32.

33 designates the bolt of the lock, plainly shown in engagement with slot 6 of the bow in Fig. 3. Projecting from the inner surface of the casing through longitudinal slot 34 in bolt 33 are the pins 35 36, the offices of which are to maintain the bolt in its proper position while it is shot back and forth within the casing by means of a key of common design and operation acting upon the serrations 37 of the bolt.

Number 38 designates a flat spring having one end fixed upon the inner surface of the side of the casing (see Figs. 3 and 4) and a free end adapted to bear against a triangular block 39, which may be turned upon pivot 40.

An explanation of the mode of operating our invention will now be clearly understood. It will be seen, Fig. 2, that when plate 31 is swung to the right upon its pivot 32 block 24 is correspondingly moved by pin 29, the end 28 of the pin being engaged with a suitable orifice through the block. (See Fig. 4.) It has already been stated that one edge of slot 25 of the block is fashioned for engagement with pin-hook 23 when cover 19 is closed. Upon motion of the block 24 the pin-hook is released and the cover thrown upwardly by spring 22, an operation easily followed in Figs. 1, 3, and 4. Our practice is and has been to form the hinged cover 19 with such care that no space remains between it and the keyhole guard-plate 7 when those parts are brought into contact. So intimate is the contact customarily that it is practically impossible to introduce a thin sheet of paper in the joint. Plate 7 is intentionally fixed upon the casing in such manner that there is nothing to indicate the fact that it is fixed, nor is it apparent to the most careful observer that any differ-

ence of condition exists between the fixed plate 7 and pivoted plate 31. Even after plate 31 has been moved sidewise and the cover 19 released the problem has not been solved, as the uninformed operator must yet guess or hit upon by trial the movement of sliding plate 10, which brings keyhole 12 into registry with the true keyhole 15 through the casing. Inserted in the false keyhole 14 and turned, the key merely moves the triangular block 39 upon its pivot 40 until key and block separate, when the latter is returned quickly to its original position by spring 38, the only apparent effect being an audible click or snap heard as the parts come together. The office of the triangular block and spring is to interpose in the path of the turning key about the same resistance as that encountered when the true keyhole is discovered and the bolt engaged. No hint is thus given the uninformed operator that a second keyhole must be sought for.

It will be at once perceived that a person must be acquainted with two distinct secret movements before the lock can be released, even though the key may be in the possession of such person. It is obvious, further, that the construction of the lock and key proper may be widely varied within the scope of our invention.

Not the least important feature of our invention is that, owing to the essential fact that all joints are practically effaced, the lock is to all intents and purposes waterproof, and, when made of suitable materials, non-corrodible.

What we claim, and desire to protect by Letters Patent of the United States, is—

1. In a padlock, the combination of a casing, said casing having suitable orifices and keyholes, a pivoted bow, a bolt adapted to be operated by a key, said bow constructed for engagement with said bolt, a fixed keyhole guard-plate having a longitudinal slot and recess, a sliding keyhole-plate provided with suitable orifices, a keyhole-cover consisting of a fixed and a hinged portion, said hinged portion possessing a pin-hook, a pivoted back plate, spring-operated devices within said casing adapted to engage said pin-hook, and connections between said back plate and spring-operated devices whereby the pin-hook may be released, substantially as described.

2. In a padlock, the combination of a casing, said casing having suitable orifices and keyholes, a pivoted bow, a bolt adapted to be operated by a key, said bow constructed for engagement with said bolt, a fixed keyhole guard-plate having a longitudinal slot and recess, a sliding keyhole-plate provided with suitable orifices, a keyhole-cover consisting of a fixed and a hinged portion, said hinged portion possessing a pin-hook and longitudinal recess, a curved spring having one end fixed in said recess, a pivoted back plate, spring-operated devices within said casing adapted to engage said pin-hook, and connec-

tions between said back plate and spring-operated devices whereby said pin-hook may be released, substantially as described.

3. In a padlock, the combination of a casing, said casing having suitable orifices and keyholes, a pivoted bow, a bolt adapted to be operated by a key, said bow constructed for engagement with said bolt, a fixed keyhole guard-plate having a longitudinal slot and recess, a sliding keyhole-plate provided with suitable orifices, a keyhole-cover consisting of a fixed and a hinged portion, said hinged portion possessing a pin-hook and longitudinal recess, a curved spring having one end fixed in said recess, a pivoted back plate,

spring-operated devices within said casing adapted to engage said pin-hook, connections between said back plate and spring-operated devices whereby said pin-hook may be released, a pivoted angular block, and a flat spring fixed to said casing, constructed and arranged substantially as shown and described, for the purposes set forth.

In testimony whereof we affix our signatures in presence of two witnesses.

THEODOR GRABOWSKI.
KAZIMIERZ JURKOWSKI.

Witnesses:

CHARLES SCHUNÉDEHAUSEN,
ADOLF SULKOWSKI.