

[54] AUTOMATIC TUBE EXTRACTOR

[72] Inventor: Donald J. Hopko, Yonkers, N.Y.

[73] Assignee: Windings, Inc., Yonkers, N.Y.

[22] Filed: Sept. 1, 1970

[21] Appl. No.: 68,664

[52] U.S. Cl.242/18 R, 242/43, 242/163

[51] Int. Cl.B65h 54/00

[58] Field of Search242/18 R, 163, 43

[56] References Cited

UNITED STATES PATENTS

3,578,255 5/1971 Gordon et al.242/18 R

Primary Examiner—Stanley N. Gilreath

Attorney—Jennings Bailey, Jr.

[57] ABSTRACT

In the winding of a package of flexible material of the universal type with a radial opening, the inner end of the material being led out through the radial opening for twistless payout, in order to make the inner end available when the package is completed and at the same time to provide the radial hole with a guide tube, a rotary switch is connected to a retracting oscillating guide for flexible material which rests on the face of the material being wound and controls a motor mounted inside the mandrel on which the flexible material is being wound. This motor through a cam and follower advances a guide tube, through which the inner end of the material has been threaded, through the radial hole which is formed during the winding at substantially the same rate that the package builds up.

1 Claims, 6 Drawing Figures

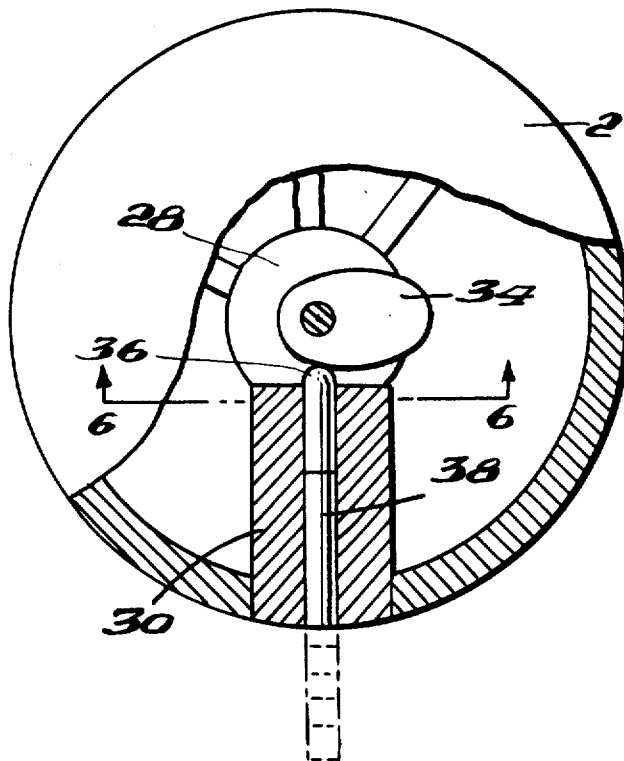

Fig. 1.

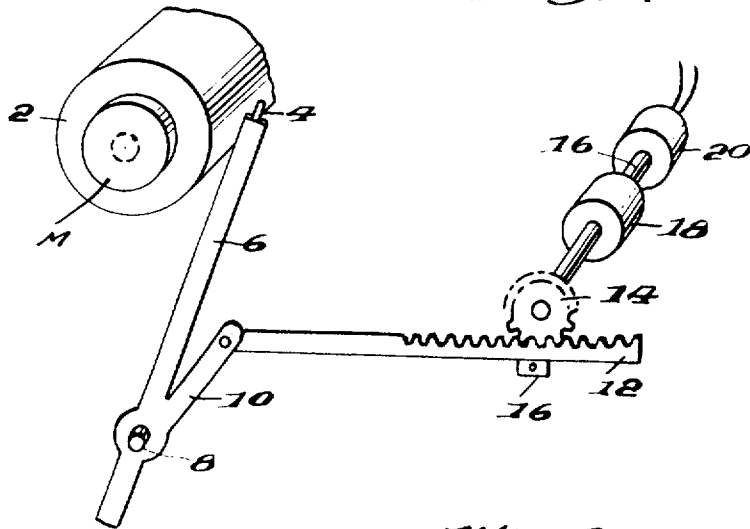

Fig. 3.

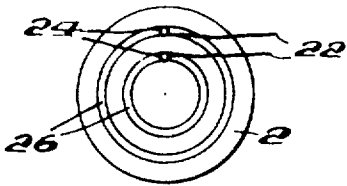

Fig. 2.

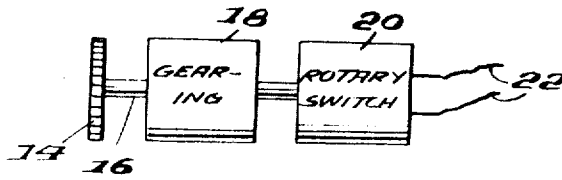

Fig. 5.



Fig. 4.

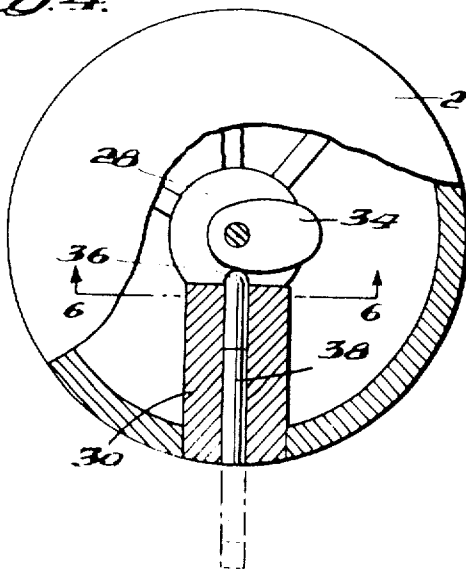
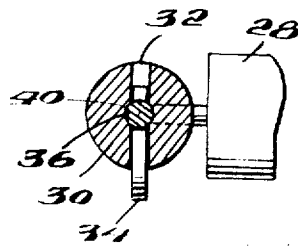

Fig. 6.



INVENTED BY

James G. ...
ATTORNEY

AUTOMATIC TUBE EXTRACTOR

BACKGROUND OF THE INVENTION

1. Field of the Invention

The invention relates to an arrangement for bringing out the inner end of the flexible material in a universal wound type package with a radial opening.

2. The Prior Art

Devices for producing packages of the type shown herein are well known, as shown for example by the Taylor U.S. Pat. No. 2,767,938. There is also pending an application of William F. Gordon and James W. Newman, Ser. No. 818,731, filed Apr. 23, 1969, for Production of a Twistless Payout Package With Means for Drawing Out the Inner End of the Material. That application shows an arrangement in which a member to which the inner end of the material is secured is fed outwardly a the package builds up by a gearing arrangement which depends upon the rotation of the spindle for its actuation.

SUMMARY OF THE INVENTION

The present invention provides an arrangement in which a tube or other holding arrangement for holding the inner free end of the material is fed outwardly under the control of the retrogression of the oscillating or reciprocating guide which carries the flexible material back and forth across the face of the rotating spindle and which rests on the surface of the material being wound. The control of the projection of the tube or other holding member through the package during its formation is thus directly controlled in accordance with a build-up of the package the mandrel, whereas in the prior device a deviation is possible, because of variations in tension or the like, between the theoretical and the actual surface layers.

In general, the invention contemplates the use of a rack connected with the reciprocating guide in such a way it moves in unison with the retraction of the guide from the mandrel. This rack controls through suitable gearing a rotary switch which at each rotation imparts an electrical impulse to a step by step motor located inside the mandrel. This motor turns a cam which through a follower guided in a block mounted inside the mandrel pushes a tube or other member to which the free end of the material is attached outwardly from the face of the mandrel as the package builds up.

BRIEF DESCRIPTION OF THE DRAWING

In the drawings

- FIG. 1 shows partly in perspective and schematically a part of the apparatus embodying the invention;
- FIG. 2 shows the gearing and rotary switch;
- FIG. 3 shows an end view of the mandrel;
- FIG. 4 shows an end view of the mandrel partly in section;
- FIG. 5 is a cross-section through a guide tube and;
- FIG. 6 is a cross-section substantially along the line 6—6 of FIG. 4.

DESCRIPTION OF THE PREFERRED EMBODIMENTS

In the arrangement shown in FIG. 1, M is a motor driving a mandrel 2. A guide 4 is mounted on an arm 6 for reciprocatory movement along the face of the mandrel 2, which at the same time is carried by a shaft 8. The guide rests on the surface of the package being wound, so as to push the guide back as the package builds up. The mounting such a mandrel and guide in this way is well known.

Connected to the shaft 8 is an arm 10 to which is pivoted a rack 12 engaging a pinion 14 and held against it by a guide member 16. Pinion 14 in turn through shaft 16 turns high ratio gearing 18 which in turn drives rotary switch 20 at a speed many times that of the gearing 14. Switch 20 closes once at each revolution, and thereby sends current to wires 22. These

wires in turn are connected to brushes 24 which engage slip rings 26 on one end of the mandrel 2. Slip rings 26 are in turn connected to a motor 28 located inside the mandrel.

The mandrel is hollow and has projecting inwardly from one face pair of blocks 30, with a space 32 between them. Motor 28 drives a cam 34 which is capable of moving within the space 32, and operating a follower 36. The follower 36 in turn engages against a tube 38. The space 32 is less in width than the diameter of the follower 36 and tube 38, so that grooves 40 are provided in the walls of the block 30 which act as guides for the follower and the tube.

The tube 38 may have in one wall a groove 42 for reasons to be explained below.

The arrangement operates as follows:

As the mandrel is rotated and the guide reciprocated, a package is built up on the mandrel. During this build up a radial hole is caused to form opposite the blocks 36, for example in the manner described in Taylor U.S. Pat. No. 2,767,938 referred to above. As the guide arm 6 retracts, rack 12 turns the pinion 14 which turns shaft 16 much more rapidly and cause frequent periodical signals from the rotary switch 20 to be transmitted to the motor 28. This results in the rotation of cam 34 which gradually pushes the follower 36 and this pushes the tube 38 out through the opening being formed. When the package is completed, the inner end of the tube 38 will be at or slightly above the outer surface of the mandrel 2. The follower 36 can then be allowed to retract, for example by manual operation or by manual reversal of power to the motor 28, whereupon the package can be slipped off the mandrel.

If it is desired to have a tube within the finished package as a guide tube, the tube is provided as shown in FIG. 5 with a groove 42 in one side. Before starting the wind, the beginning end of the material is brought through the tube from what is to be the inner end, and then the last section is laid in the groove 42, the inner end being positioned at the upper end of the tube. When the package is completed, the tube will be in position in the hole and the free inner end of the material will be passed up through it readily for withdrawal.

By reason of the fact that the guide is caused to retract by the actual build up of the material of the package, the tube or other member is always advanced by the proper amount and thus maintained in the proper relation to the surface of the material. In contrast, when the rotation of the spindle is relied on, this relation may be disturbed by variations in the tension with which the material is wound, which would cause the thickness of the package wall to vary; by variations in the thickness of the material, which would have the same effect; or by other variables.

If on the other hand the material is to be fed without a guide tube, a solid bar could be used instead of the tube 38, the free inner end of the material being merely secured to the end of this bar.

I claim:

- 1. In machine for winding a package of flexible material having a plurality of layers each formed of a plurality of figure 8 bights with the cross-overs progressing around the package and with a radial opening therein through which the free inner end of the material can be drawn out, said machine including a spindle on which the material is wound and means to rotate the spindle, a guide for flexible material, means to move said guide back and forward along the face of the spindle while engaging the face of the material being wound on the spindle so as to retract the guide as the package builds up on the spindle, said spindle having a radial opening therein, a member slidably mounted in said opening, and to move said member outwardly through the opening in the package as a package is built up on the spindle, and control means for said member moving means connected directly with the guide and operated thereby in synchronism with the retraction of said guide.

* * * * *