



- (51) International Patent Classification:
E21B 33/08 (2006.01) F16J 15/16 (2006.01)
F16C 33/72 (2006.01)
- (21) International Application Number:
PCT/CA2015/050019
- (22) International Filing Date:
13 January 2015 (13.01.2015)
- (25) Filing Language: English
- (26) Publication Language: English
- (30) Priority Data:
2,839,151 14 January 2014 (14.01.2014) CA
- (71) Applicant: STRATA ENERGY SERVICES INC.
[CA/CA]; 27312 - 245 Twp. Rd. 394, Blackfalds, Alberta
T0M0J0 (CA).
- (72) Inventors: TRAVIS, Kenneth; 27312 - 245 Twp. Rd.
394, Blackfalds, Alberta T0M0J0 (CA). FILLIOL, Lyle;
27312 - 245 Twp. Rd. 394, Blackfalds, Alberta T0M0J0

(CA). WILSON, Stewart; 27312 - 245 Twp. Rd. 394,
Blackfalds, Alberta T0M0J0 (CA).

(74) Agent: WOODRUFF, Nathan; 200, 10328 - 81 Avenue
NW, Edmonton, Alberta T6E1X2 (CA).

(81) Designated States (unless otherwise indicated, for every
kind of national protection available): AE, AG, AL, AM,
AO, AT, AU, AZ, BA, BB, BG, BH, BN, BR, BW, BY,
BZ, CA, CH, CL, CN, CO, CR, CU, CZ, DE, DK, DM,
DO, DZ, EC, EE, EG, ES, FI, GB, GD, GE, GH, GM, GT,
HN, HR, HU, ID, IL, IN, IR, IS, JP, KE, KG, KN, KP, KR,
KZ, LA, LC, LK, LR, LS, LU, LY, MA, MD, ME, MG,
MK, MN, MW, MX, MY, MZ, NA, NG, NI, NO, NZ, OM,
PA, PE, PG, PH, PL, PT, QA, RO, RS, RU, RW, SA, SC,
SD, SE, SG, SK, SL, SM, ST, SV, SY, TH, TJ, TM, TN,
TR, TT, TZ, UA, UG, US, UZ, VC, VN, ZA, ZM, ZW.

(84) Designated States (unless otherwise indicated, for every
kind of regional protection available): ARIPO (BW, GH,
GM, KE, LR, LS, MW, MZ, NA, RW, SD, SL, ST, SZ,
TZ, UG, ZM, ZW), Eurasian (AM, AZ, BY, KG, KZ, RU,
TJ, TM), European (AL, AT, BE, BG, CH, CY, CZ, DE,

[Continued on next page]

(54) Title: MODULAR SEALING ELEMENTS FOR A BEARING ASSEMBLY

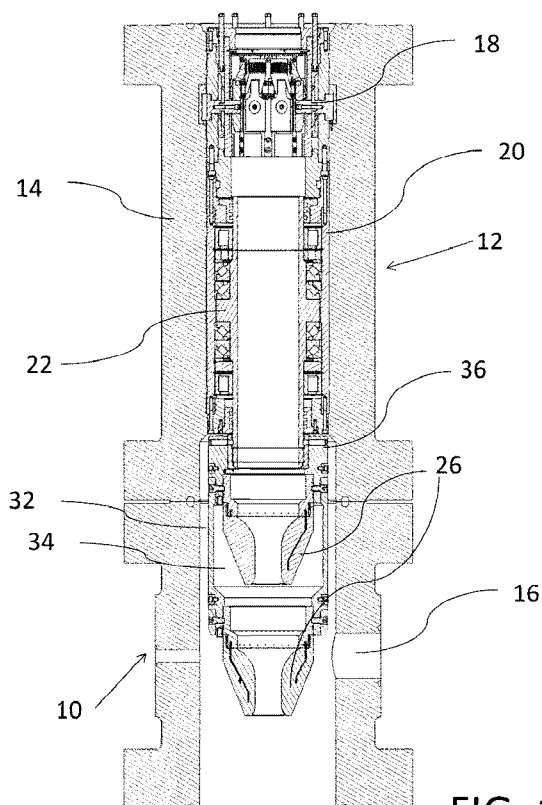

FIG. 1

(57) Abstract: ABSTRACT OF THE DISCLOSURE There is provided
a sealing assembly for a bearing assembly that supports a rotating
tubing string that extends through the riser. The sealing assembly has a
plurality of sealing elements. Each sealing element has a seal body hav-
ing an inner sealing surface designed to seal against a tubular body.
The sealing assembly also has one or more sleeves that removably at-
tach between adjacent sealing elements. Adjacent sealing elements are
attached to the one or more sleeves in axial alignment. A chamber is
formed by the adjacent sealing elements and the corresponding sleeve.
The sealing assembly further has a bearing attachment for attaching the
plurality of modular sealing elements to a rotating portion of the bear-
ing assembly such that the sealing elements extend downward in series
from the bearing assembly and rotate with the rotating tubing string.

WO 2015/106351 A1

DK, EE, ES, FI, FR, GB, GR, HR, HU, IE, IS, IT, LT, **Published:**
LU, LV, MC, MK, MT, NL, NO, PL, PT, RO, RS, SE, — *with international search report (Art. 21(3))*
SI, SK, SM, TR), OAPI (BF, BJ, CF, CG, CI, CM, GA,
GN, GQ, GW, KM, ML, MR, NE, SN, TD, TG).

TITLE

[0001] Modular sealing elements for a bearing assembly

TECHNICAL FIELD

5 [0002] This relates to modular sealing elements for a bearing assembly that may be used with a subsea hydrocarbon producing well.

BACKGROUND

10 [0003] In order to seal around a drill pipe or other tubular body in a subsea location, sealing elements are provided and are generally mounted to a bearing assembly. United States patent no. 6,244,359 (Bridges et al.) entitled ‘Subsea diverter and rotating drilling head’ describes an example of a bearing and seal assembly for a subsea drilling head.

SUMMARY

15 [0004] According to an aspect, there is provided a sealing assembly for a bearing assembly, the bearing assembly having a fixed portion attached to a riser of a subsea wellhead and rotating portion attached to a rotating tubing string that extends through the riser. The sealing assembly comprises a plurality of sealing elements, and each sealing element comprises a seal body having an inner sealing surface designed to seal against a tubular body.

20 The sealing assembly comprises one or more sleeves that removably attach between adjacent sealing elements, the adjacent sealing elements being to the one or more sleeves in axial alignment. A chamber is formed by the adjacent sealing elements and the corresponding sleeve. There is a bearing attachment for attaching the plurality of modular sealing elements to a rotating portion of the bearing assembly such that the sealing elements extend downward

25 in series from the bearing assembly and rotate with the rotating tubing string.

[0005] According to another aspect, the sealing element may have a first end and a second end, and the first end may be attached to the sealing sleeve and the inner sealing surface may be positioned toward the second end.

30

[0006] According to another aspect, each sealing element may define an inner sealing diameter.

[0007] According to another aspect, there may be at least one sealing element with a different inner sealing diameter than another sealing element.

[0008] According to another aspect, the one or more sleeves may comprise connection
5 seals at each of the first and second ends.

[0009] According to another aspect, each sleeve may attach to a first end of the sealing elements, such that an upper sealing element extends into the chamber.

10 [0010] According to another aspect, the inner sealing surface may be positioned toward a second end of the sealing element.

[0011] According to another aspect, the one or more attachment sleeves have first and second ends and the first end may be sized to nest with adjacent sleeves such that each of the
15 first and second ends may be simultaneously attached to a respective sealing element.

[0012] According to another aspect, the sealing assembly may further comprise a cap ring that may engage the second end of the attachment sleeve at the end of the series of sealing elements.
20

[0013] According to another aspect, each sealing element may comprise a rigid attachment portion for attaching to the sleeve and an elastomeric sealing portion that may be carried by the attachment portion.

25 [0014] According to another aspect, the sealing assembly may further comprise at least one sensor for sensing at least one of the pressure and the temperature within at least one chamber. The sensor may transmit the readings wirelessly.

[0015] According to another aspect, each sealing element may carry a sensor for sensing
30 at least one of pressure and temperature. The sensors may transmit the readings wirelessly.

BRIEF DESCRIPTION OF THE DRAWINGS

[0016] These and other features will become more apparent from the following description in which reference is made to the appended drawings, the drawings are for the purpose of illustration only and are not intended to be in any way limiting, wherein:

5 **FIG. 1** is a side elevation view in section of a latching assembly securing a bearing assembly and element module assembly in a riser.

FIG. 2 is a side elevation view in section of a latching assembly securing a bearing assembly in a riser showing three modular sealing elements with different sized openings.

10 **FIG. 3** is a side elevation view in section of a modular sealing element assembly.

FIG. 4 is a side elevation view of a latching assembly securing a bearing assembly and element module assembly in a riser.

DETAILED DESCRIPTION

15 [0017] A modular sealing assembly generally identified by reference numeral 10, will now be described with reference to **FIG. 1** through **4**.

[0018] Referring to **FIG. 4**, sealing assembly 10 is attached to a bearing assembly 12 that is supported within a riser 14 of a subsea wellhead by a latch assembly 18. Referring to **FIG. 1**, the bearing assembly 12 has a non-rotating portion 20 seated in riser 14. Riser 14 has a port 16 for pumping fluids. Port 16 is designed to be attached to a conduit (not shown) for pumping fluids, such as drilling mud out from the wellbore. As shown, bearing assembly 12 is supported within riser 14 by a latch 18. Bearing assembly 12 may be supported within riser 14 in various ways as will be recognized by those skilled in the art, however the particular latch 18 that is depicted in the drawings is described in PCT application no. CA2013/050692. The bearing assembly 12 also has a rotating portion 22 that attaches to a rotating tubing string 24 (shown in **FIG. 4**) that extends through the riser 14. As shown, the rotating tubing string 24 enters the bearing assembly 12 and the sealing assembly 10. The rotating tubing string 24 enters a plurality of sealing elements 26, and the seal element body 28 seals about the rotating tubing string 24 at inner sealing surface 30 (shown in **FIG. 3**). The bearing assembly 12 allows the sealing elements 26 to rotate with the rotating tubing string 24.

20

25

30

[0019] Sealing assembly 10 is made up of a plurality of sealing elements 26 that are designed to be modular. This allows them to be attached together in a stack of a desired configuration. Each sealing element 26 has a seal body 28 (shown in **FIG. 3**) with an inner sealing surface 30 designed to seal against a tubular body, such as rotating tubing string 24, shown in **FIG. 4**. Referring again to **FIG. 1**, adjacent sealing elements 26 are removably attached by sleeves 32. Referring to **FIG. 2** and **3**, each sleeve 32 has a first end 38 and a second end 40. Each second end 40 is design to be attached to a seal element 26. This results in more than one seal element 26 attached in series below bearing assembly 12. Sleeve 32 maintains adjacent sealing elements 26 in axial alignment and forms a chamber 34 between the adjacent sealing elements 26. Sleeve 32 preferably includes seals 33 at each of first and second ends 38 and 40 to seal chamber 34. Sleeves 32 with first 38 and second 40 ends may be sized such that they nest with adjacent sleeves 32 such that each of the first 38 and second 40 ends are simultaneously attached to the sealing element 26.

15

[0020] Referring to **FIG. 3**, in the depicted embodiment, the sealing element 26 has the sleeve 32 attached to a first end 38 of the sealing element 26 above, such that the upper sealing element 26 extends down into the chamber 34. In this case, the inner sealing surface 30 is positioned toward a second end 40 of the sealing element 26. As shown, the sealing element 26 defines an inner sealing diameter 42. In the preferred embodiment, sleeve 32 further comprises a cap ring that engages the end of the attachment sleeve 32 and the second end 40 of the sealing element 26, such that it finishes the series of sealing elements 26 at the end of the sealing assembly 10. Each sealing element 26 may comprise a rigid attachment portion 46 in the region of the first end 52 of the sealing element 26 for attaching to the sleeve 32, and an elastomeric sealing portion 48 in the region of the second end 54 of the sealing element 26 defining the inner sealing surface 30, and the elastomeric sealing portion 48 is carried by the rigid attachment portion 46. The sealing assembly 10 is attached to the rotating portion 22 of the bearing assembly 12 with a bearing attachment 36. They are attached such that the sealing elements 26 extend downward in series from the bearing assembly 12 and rotate with the rotating tubing string 24. Bearing attachment 36 has an attachment on the outer surface that is sized and shaped similar to second end 40 of sleeve 32 such that it allows

20
25
30

sleeve 32, and therefore the stack of sealing elements 26, to attach to bearing attachment 36.

[0021] Referring to **FIG. 2**, there may be at least one sealing element 26 with a different inner sealing diameter 42 than another sealing element 26. This allows the user to provide multiple sealing diameters to seal against different sizes of tubular bodies that may extend through sealing assembly 10.

[0022] In the preferred embodiment, the sealing assembly 10 has sensors 50 (not shown) for sensing conditions within chambers 34. Sensors may sense, for example, pressure, temperature or others. There may be one sensor for each condition sensed, or a sensor that senses multiple conditions. Sensors 50 can be carried by sealing elements 26, but may also be carried by sleeves 32. Preferably, there is a sensor 50 for each chamber 34, although the number of sensors and the chambers in which they are positioned may be determined by the user. There may also be sensors positioned to determine conditions within riser 14 outside sealing assembly 10. Preferably, sensors 50 transmit the readings wirelessly although they may be connected to transmit along a wired connection. To reduce the power and design requirements of sensors 50, bearing assembly 12 may have a communication module (not shown) that receives the signals from sensors 50 and transmits the readings to surface, either wirelessly or using a wired connection.

20

Operation:

[0023] After the creation of a wellbore by any known method, a riser 14 is inserted into the wellbore. The riser 14 carries a latching assembly 18. Port 16 of riser 14 is connected to a conduit allowing for fluids to be pumped out from the wellbore. Next the sealing assembly may be assembled.

25

[0024] Referring to **FIG. 2**, sealing assembly 10 is assembled by attaching sealing elements 26 together using sleeves 32. Each sleeve 32 has a first end 38 and a second end 40. The first end 38 of the first sealing element 26 in the stack of sealing elements will be connected to bearing attachment 36. This first sealing element 26 will be sized to attach to the exterior of bearing assembly 12, using a pin connector going through first end 38 and bearing

30

attachment 36. In turn, bearing attachment 36 is attached to bearing assembly 12 using pin connectors. First end 38 preferably has a seal 33 at the first end 38, which when the pin connector attaches the first sealing element 26 to bearing attachment 36 will create a seal between first sealing element 26 and bearing assembly 12. The second end 40 of the first sleeve 32 will have an opening sized to receive another pin connector, and will also carry a seal 33. Additional sealing elements 26 are attached to the opening at the second end of the sleeve 32 which was attached prior. A sealing element 26 that is attached to the second end 40 of another sleeve 32 will carry a pin connector that will form a connection to attach the second end 40 of the prior sleeve 32 to the first end 38 of the new sleeve 32. Seals 33 on the first end 38 and the second end 40 will meet each other and form a sealed connection such that chamber 34 will be sealed from the exterior of the sealing assembly 10. Sealing assembly 10 will be formed by nesting together successive sealing elements 26 using pin connections and seals until the sealing assembly has reached the desired length. The final second end 40 will not receive an additional sleeve 32 to attach to the opening which would receive a pin connection, and will instead receive a cap ring 44 which also carries a pin connection to be attached to the final sealing element 26 at the the second end 40 of the final sleeve 32. This will finish the sealing assembly 10.

[0025] Referring to **FIG. 2** and **4**, the sealing assembly 10 which is attached to the rotating portion 22 at the bottom of the bearing assembly 12, can now be introduced into the wellbore. The sealing assembly 10 and bearing assembly 12 are together inserted into riser 14 and supported within riser 14 by latch assembly 18. The bearing assembly 12 is latched into place on the fixed portion 20 of bearing assembly 12 using latch assembly 18.

[0026] Once the bearing and sealing assemblies are in place, a tubular body is then inserted through bearing assembly 12 and sealing assembly 10. In the shown embodiment, a rotating tubing string such as 24 enters the bearing assembly 12 and the sealing assembly 10. As the rotating tubing string 24 is pushed through each sealing body 26, the sealing body 26 seals about the rotating tubing string 24 such that the sealing elements 26 will rotate with the rotating tubing string 24 due to the bearing assembly 12.

[0027] Referring to **FIG. 2**, the sealing assembly 10 may have sealing elements 26 with different inner sealing diameters 42. In this case, when the tubular body is inserted through the sealing elements, only those sealing elements with a sufficiently small inner sealing diameter will seal against the tubular body. This will allow for tubular bodies with different diameters to be used within the same sealing assembly 10.

[0028] In this patent document, the word "comprising" is used in its non-limiting sense to mean that items following the word are included, but items not specifically mentioned are not excluded. A reference to an element by the indefinite article "a" does not exclude the possibility that more than one of the element is present, unless the context clearly requires that there be one and only one of the elements.

[0029] The scope of the following claims should not be limited by the preferred embodiments set forth in the examples above and in the drawings, but should be given the broadest interpretation consistent with the description as a whole.

What is Claimed is:

1. A sealing assembly for a bearing assembly, the bearing assembly having a fixed
5 portion attached to a riser of a subsea wellhead and rotating portion attached to a rotating
tubing string that extends through the riser, the sealing assembly comprising:
a plurality of sealing elements, each sealing element comprising a seal body having an
inner sealing surface designed to seal against a tubular body;
one or more sleeves that removably attach between adjacent sealing elements, the
10 adjacent sealing elements being attached to the one or more sleeves in axial alignment,
wherein a chamber is formed by the adjacent sealing elements and the corresponding sleeve;
a bearing attachment for attaching the plurality of modular sealing elements to a
rotating portion of the bearing assembly such that the sealing elements extend downward in
series from the bearing assembly and rotate with the rotating tubing string.
15
2. The sealing assembly of claim 1, wherein the sealing element has a first end and a
second end, the first end being attached to the sealing sleeve and the inner sealing surface is
positioned toward the second end.
- 20 3. The sealing assembly of claim 1, wherein each sealing element defines an inner
sealing diameter
4. The sealing assembly of claim 3, wherein at least one sealing element has a different
inner sealing diameter than another sealing element.
- 25 5. The sealing assembly of claim 1, wherein the one or more sleeves further comprise
connection seals at each of a first end and a second end of the one or more sleeves.
6. The sealing assembly of claim 1, wherein each sleeve attaches to a first end of a
30 respective sealing element, such that an upper sealing element extends into the chamber.
7. The sealing element of claim 6, wherein the inner sealing surface is positioned toward

a second end of the sealing element.

8. The sealing assembly of claim 1, wherein the one or more attachment sleeves have first and second ends and the first end is sized to nest with adjacent sleeves such that each of
5 the first and second ends are simultaneously attached to a respective sealing element.

9. The sealing assembly of claim 8, further comprising a cap ring that engages the second end of the attachment sleeve at the end of the series of sealing elements.

10 10. The sealing assembly of claim 1, wherein each sealing element comprises a rigid attachment portion for attaching to the sleeve and an elastomeric sealing portion that is carried by the attachment portion.

11. The sealing assembly of claim 1, further comprising at least one sensor for sensing at
15 least one of the pressure and the temperature within at least one chamber.

12. The sealing assembly of claim 11, wherein the at least one sensor transmits the readings wirelessly.

20 13. The sealing assembly of claim 1, wherein each sealing element carries a sensor for sensing at least one of pressure and temperature.

14. The sealing assembly of claim 13, wherein sensors transmit the readings wirelessly.

1/4

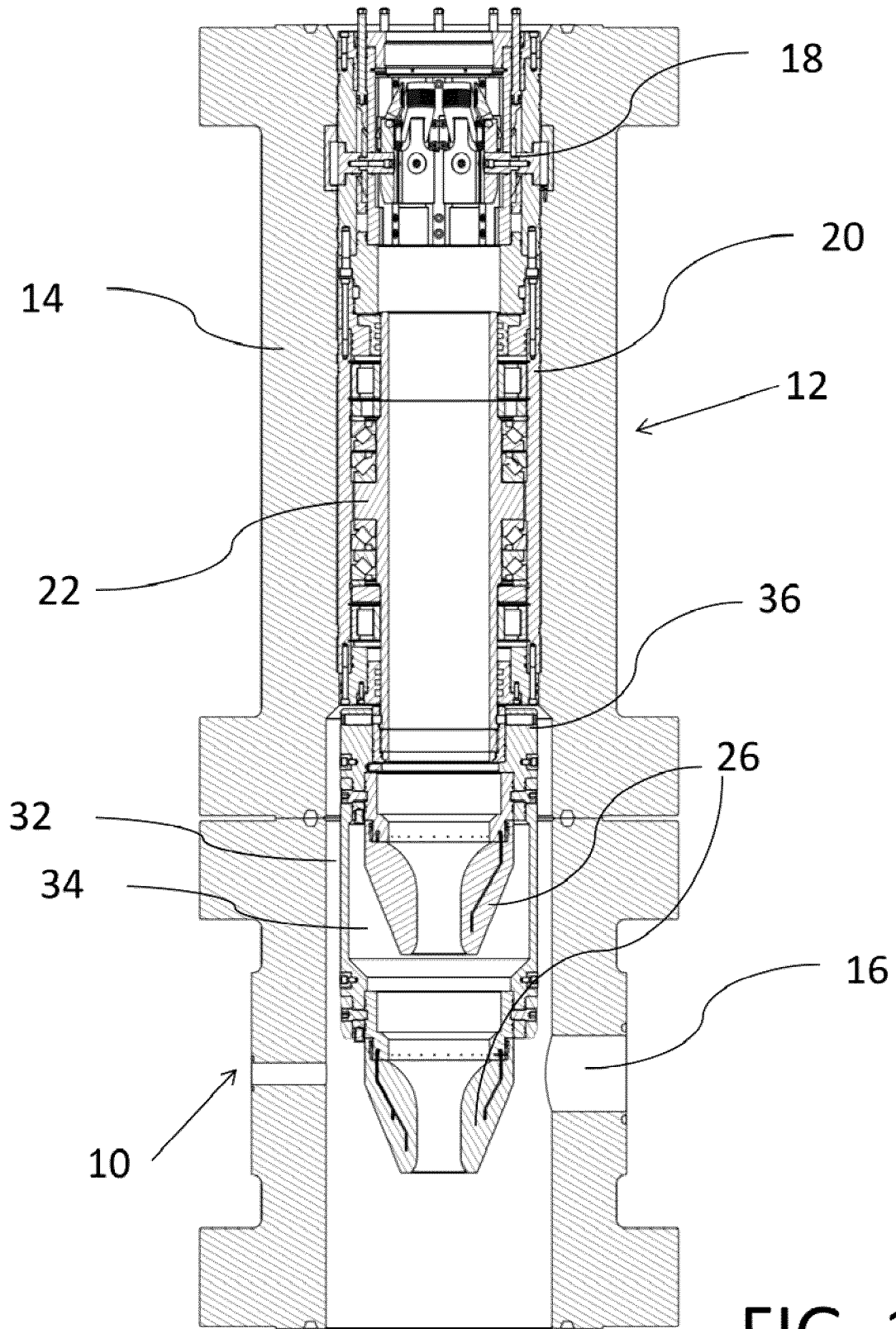

FIG. 1

2/4

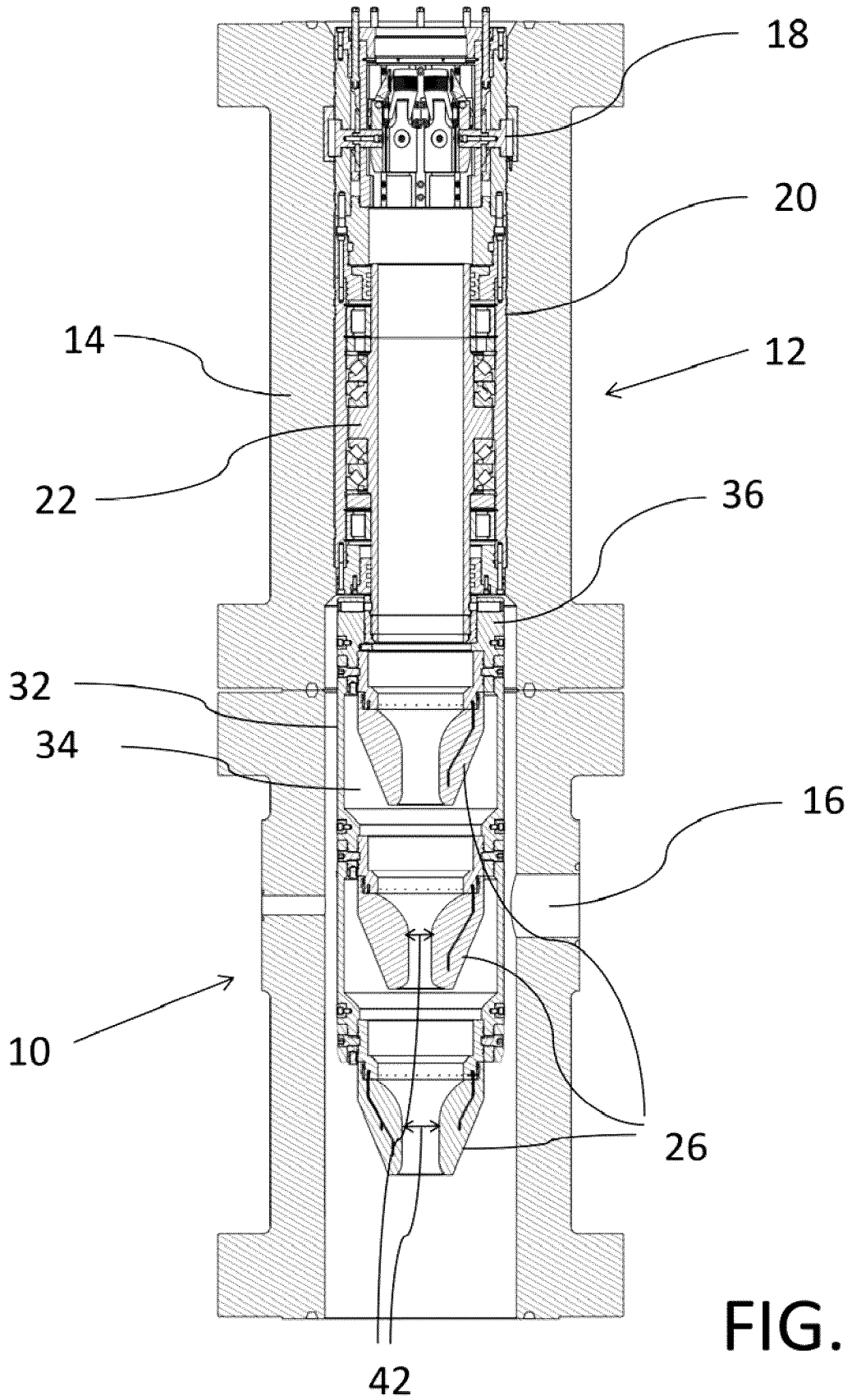

FIG. 2

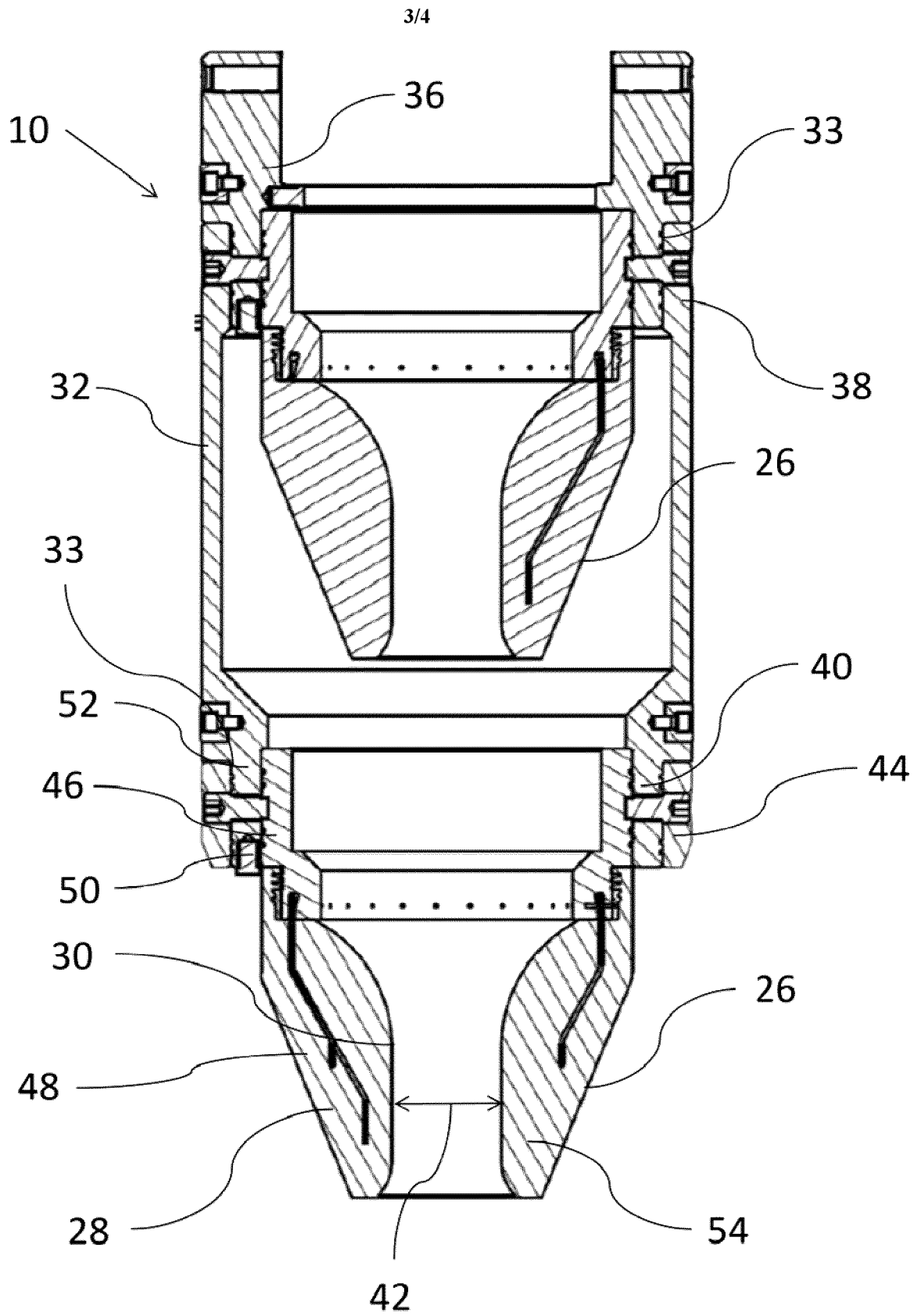

FIG. 3

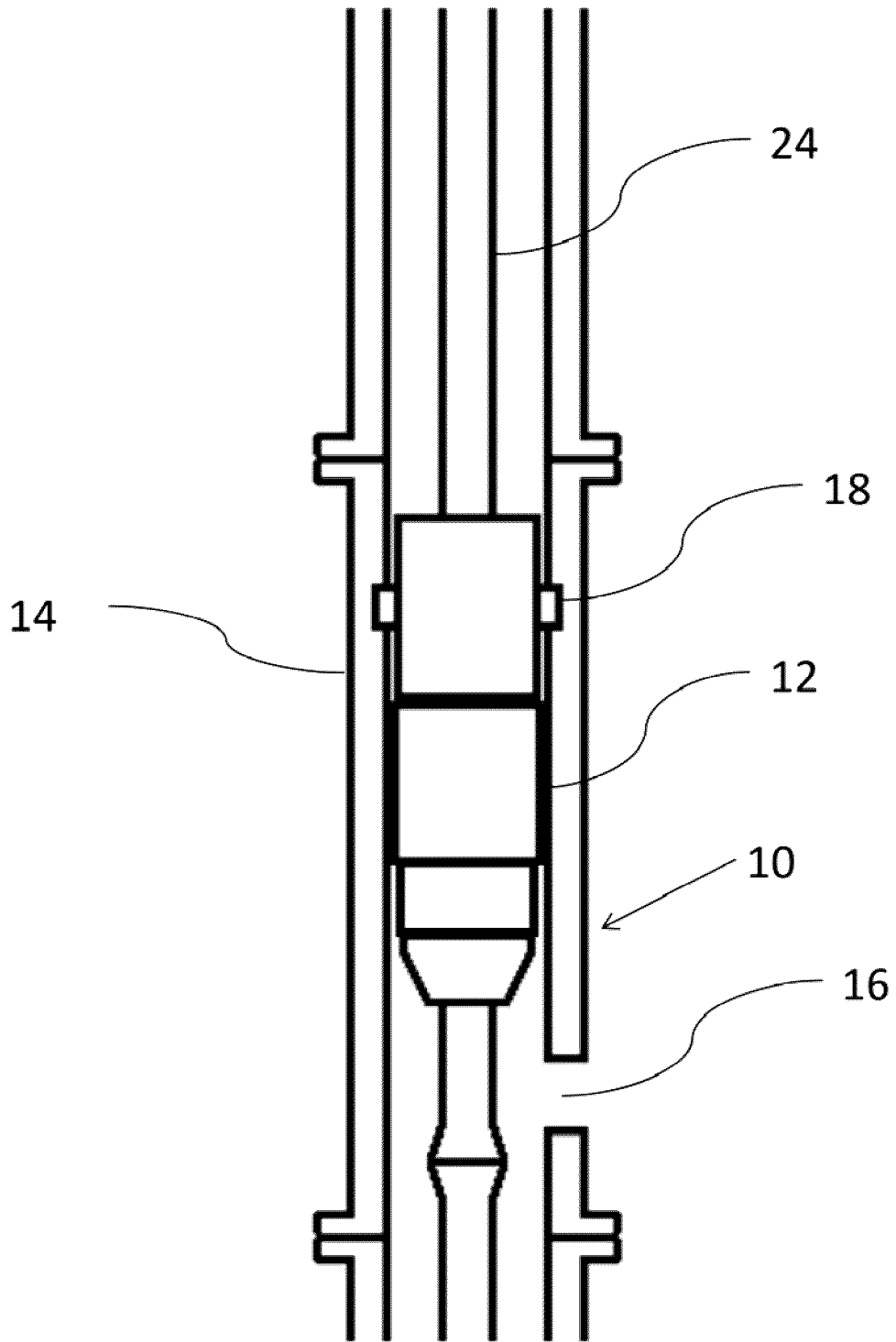

FIG. 4

INTERNATIONAL SEARCH REPORT

International application No.
PCT/CA2015/050019A. CLASSIFICATION OF SUBJECT MATTER
IPC: *E21B 33/08* (2006.01), *F16C 33/72* (2006.01), *F16J 15/16* (2006.01)

According to International Patent Classification (IPC) or to both national classification and IPC

B. FIELDS SEARCHED

Minimum documentation searched (classification system followed by classification symbols)
E21B 33/08 (2006.01), *F16C 33/72* (2006.01), *F16J 15/16* (2006.01)

Documentation searched other than minimum documentation to the extent that such documents are included in the fields searched

Electronic database(s) consulted during the international search (name of database(s) and, where practicable, search terms used)
Questel Orbit, CPD Intellect, Espacenet; keywords: bearing, bushing, seal, module, interchange, transpose, exchange, sleeve, extension, splice, append, connect, couple.

C. DOCUMENTS CONSIDERED TO BE RELEVANT

Category*	Citation of document, with indication, where appropriate, of the relevant passages	Relevant to claim No.
X	US20120043726A1 (ZUBIA, A., et al.) 23 February 2012 (23-02-2012) {figs. 2-7}	1-7, 10-14
A		8, 9
A	US20120000664A1 (NAS, S.W.M., et al.) 5 January 2012 (05-01-2012)	1-14
A	US3387851A (CUGINI, E.T.) 11 June 1968 (11-06-1968)	1-14

 Further documents are listed in the continuation of Box C. See patent family annex.

* Special categories of cited documents:	"T" later document published after the international filing date or priority date and not in conflict with the application but cited to understand the principle or theory underlying the invention
"A" document defining the general state of the art which is not considered to be of particular relevance	"X" document of particular relevance; the claimed invention cannot be considered novel or cannot be considered to involve an inventive step when the document is taken alone
"E" earlier application or patent but published on or after the international filing date	"Y" document of particular relevance; the claimed invention cannot be considered to involve an inventive step when the document is combined with one or more other such documents, such combination being obvious to a person skilled in the art
"L" document which may throw doubts on priority claim(s) or which is cited to establish the publication date of another citation or other special reason (as specified)	"&" document member of the same patent family
"O" document referring to an oral disclosure, use, exhibition or other means	
"P" document published prior to the international filing date but later than the priority date claimed	

Date of the actual completion of the international search
13 April 2015 (13-04-2015)Date of mailing of the international search report
01 May 2015 (01-05-2015)Name and mailing address of the ISA/CA
Canadian Intellectual Property Office
Place du Portage I, C114 - 1st Floor, Box PCT
50 Victoria Street
Gatineau, Quebec K1A 0C9
Facsimile No.: 001-819-953-2476Authorized officer

Edward Dabrowski (819) 953-1378

INTERNATIONAL SEARCH REPORT
Information on patent family members

International application No.
PCT/CA2015/050019

Patent Document Cited in Search Report	Publication Date	Patent Family Member(s)	Publication Date
US2012043726A1	23 February 2012 (23-02-2012)	US2012043726A1	23 February 2012 (23-02-2012)
		US8820747B2	02 September 2014 (02-09-2014)
		AR082491A1	12 December 2012 (12-12-2012)
		EA201101103A1	30 April 2012 (30-04-2012)
		EP2420647A2	22 February 2012 (22-02-2012)
		EP2420647A3	08 May 2013 (08-05-2013)
US2012000664A1	05 January 2012 (05-01-2012)	US2012000664A1	05 January 2012 (05-01-2012)
		AU2010200137A1	29 July 2010 (29-07-2010)
		AU2011317657A1	09 May 2013 (09-05-2013)
		CA2690289A1	15 July 2010 (15-07-2010)
		CA2815101A1	26 April 2012 (26-04-2012)
		EP2208855A2	21 July 2010 (21-07-2010)
		EP2208855A3	28 March 2012 (28-03-2012)
		EP2208855B1	13 November 2013 (13-11-2013)
		EP2630324A2	28 August 2013 (28-08-2013)
		EP2762671A1	06 August 2014 (06-08-2014)
		US2010175882A1	15 July 2010 (15-07-2010)
		US8322432B2	04 December 2012 (04-12-2012)
		US2012318496A1	20 December 2012 (20-12-2012)
		US8770297B2	08 July 2014 (08-07-2014)
		WO2012052402A2	26 April 2012 (26-04-2012)
WO2012052402A3	27 June 2013 (27-06-2013)		
US3387851A	11 June 1968 (11-06-1968)	None	