

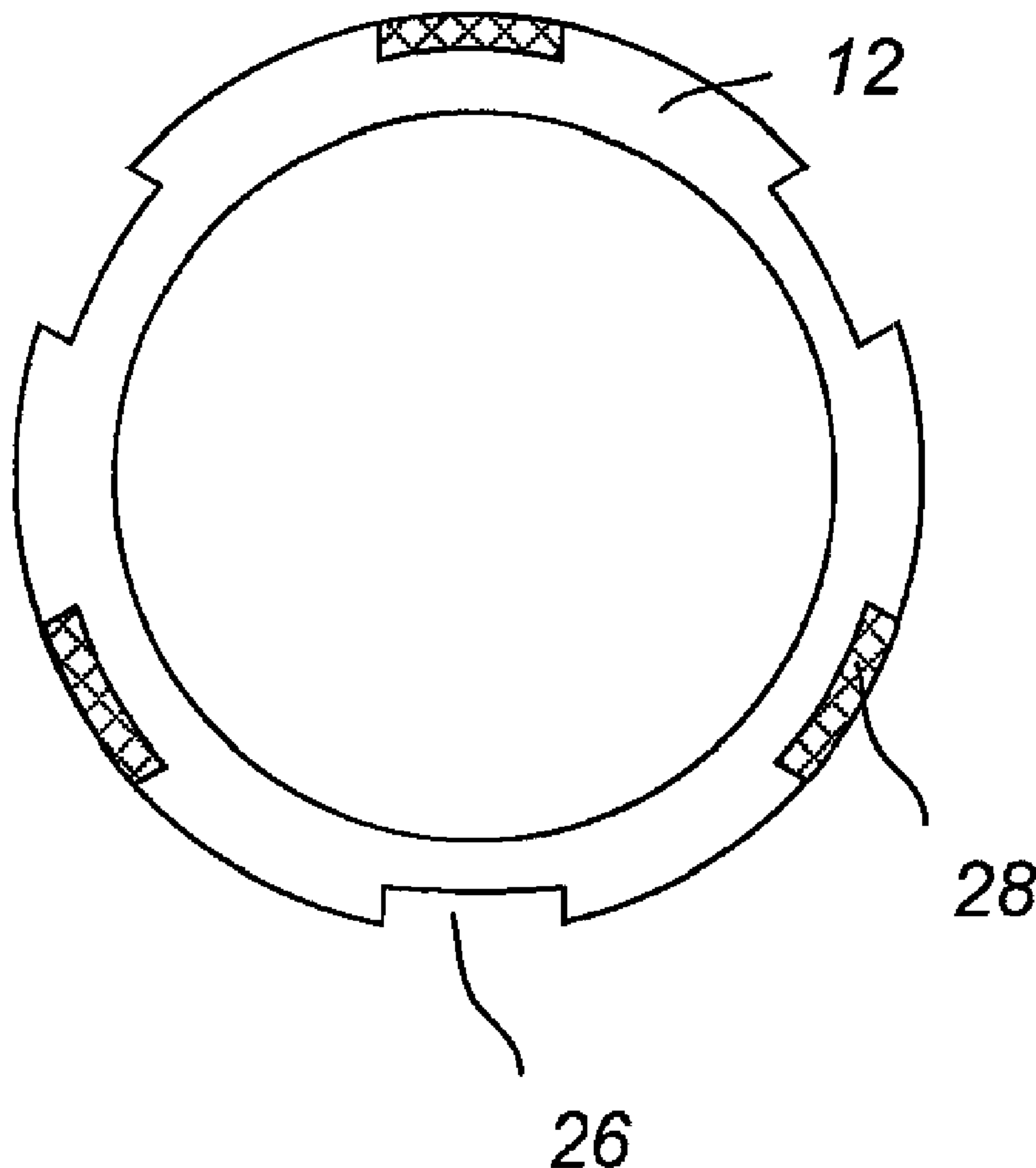

(86) **Date de dépôt PCT/PCT Filing Date:** 2007/09/17
 (87) **Date publication PCT/PCT Publication Date:** 2008/05/22
 (45) **Date de délivrance/Issue Date:** 2015/02/24
 (85) **Entrée phase nationale/National Entry:** 2009/05/13
 (86) **N° demande PCT/PCT Application No.:** US 2007/078671
 (87) **N° publication PCT/PCT Publication No.:** 2008/060750
 (30) **Priorité/Priority:** 2006/11/14 (US11/599,049)

(51) **Cl.Int./Int.Cl. A61M 25/00** (2006.01)
 (72) **Inventeurs/Inventors:**
 HOLMAN, THOMAS J., US;
 ALI, ASFAR, US
 (73) **Propriétaire/Owner:**
 BOSTON SCIENTIFIC LIMITED, BB
 (74) **Agent:** PIASETZKI NENNIGER KVAS LLP

(54) **Titre : DEGONFLAGE DE BALLONNET MEDICAL**
 (54) **Title: MEDICAL BALLOON DEFLATION**



(57) **Abrégé/Abstract:**

Medical balloons are energetically treated to form regions that facilitate deflation to a desirable configuration.

(12) INTERNATIONAL APPLICATION PUBLISHED UNDER THE PATENT COOPERATION TREATY (PCT)

(19) World Intellectual Property Organization
International Bureau



(43) International Publication Date
22 May 2008 (22.05.2008)

PCT

(10) International Publication Number
WO 2008/060750 A3

(51) International Patent Classification:

A61M 25/00 (2006.01) A61M 25/10 (2006.01)

(21) International Application Number:

PCT/US2007/078671

(22) International Filing Date:

17 September 2007 (17.09.2007)

(25) Filing Language:

English

(26) Publication Language:

English

(30) Priority Data:

11/599,049 14 November 2006 (14.11.2006) US

(71) Applicant (for all designated States except US): **BOSTON SCIENTIFIC SCIMED, INC.** [US/US]; One SciMed Place, Maple Grove, Minnesota 55311-1566 (US).

(72) Inventors; and

(75) Inventors/Applicants (for US only): **HOLMAN, Thomas, J.** [US/US]; 29625 139th Street, NW, Princeton, Minnesota 55371 (US). **ALI, Asfar** [BD/US]; 7687 Kimberly Lane N, Maple Grove, Minnesota 55311 (US).

(74) Agent: **URZEDOWSKI, James, M.**; Vidas, Arrett & Steinkraus, P.A., 6640 Shady Oak Road, Suite 400, Eden Prairie, MN 55344 (US).

(81) Designated States (unless otherwise indicated, for every kind of national protection available): AE, AG, AL, AM, AT, AU, AZ, BA, BB, BG, BH, BR, BW, BY, BZ, CA, CH, CN, CO, CR, CU, CZ, DE, DK, DM, DO, DZ, EC, EE, EG, ES, FI, GB, GD, GE, GH, GM, GT, HN, HR, HU, ID, IL, IN, IS, JP, KE, KG, KM, KN, KP, KR, KZ, LA, LC, LK, LR, LS, LT, LU, LY, MA, MD, ME, MG, MK, MN, MW, MX, MY, MZ, NA, NG, NI, NO, NZ, OM, PG, PH, PL, PT, RO, RS, RU, SC, SD, SE, SG, SK, SL, SM, SV, SY, TJ, TM, TN, TR, TT, TZ, UA, UG, US, UZ, VC, VN, ZA, ZM, ZW.

(84) Designated States (unless otherwise indicated, for every kind of regional protection available): ARIPO (BW, GH, GM, KE, LS, MW, MZ, NA, SD, SL, SZ, TZ, UG, ZM, ZW), Eurasian (AM, AZ, BY, KG, KZ, MD, RU, TJ, TM), European (AT, BE, BG, CH, CY, CZ, DE, DK, EE, ES, FI, FR, GB, GR, HU, IE, IS, IT, LT, LU, LV, MC, MT, NL, PL, PT, RO, SE, SI, SK, TR), OAPI (BF, BJ, CF, CG, CI, CM, GA, GN, GQ, GW, ML, MR, NE, SN, TD, TG).

Published:

- with international search report
- before the expiration of the time limit for amending the claims and to be republished in the event of receipt of amendments

(88) Date of publication of the international search report:

16 October 2008

(54) Title: MEDICAL BALLOON DEFLATION

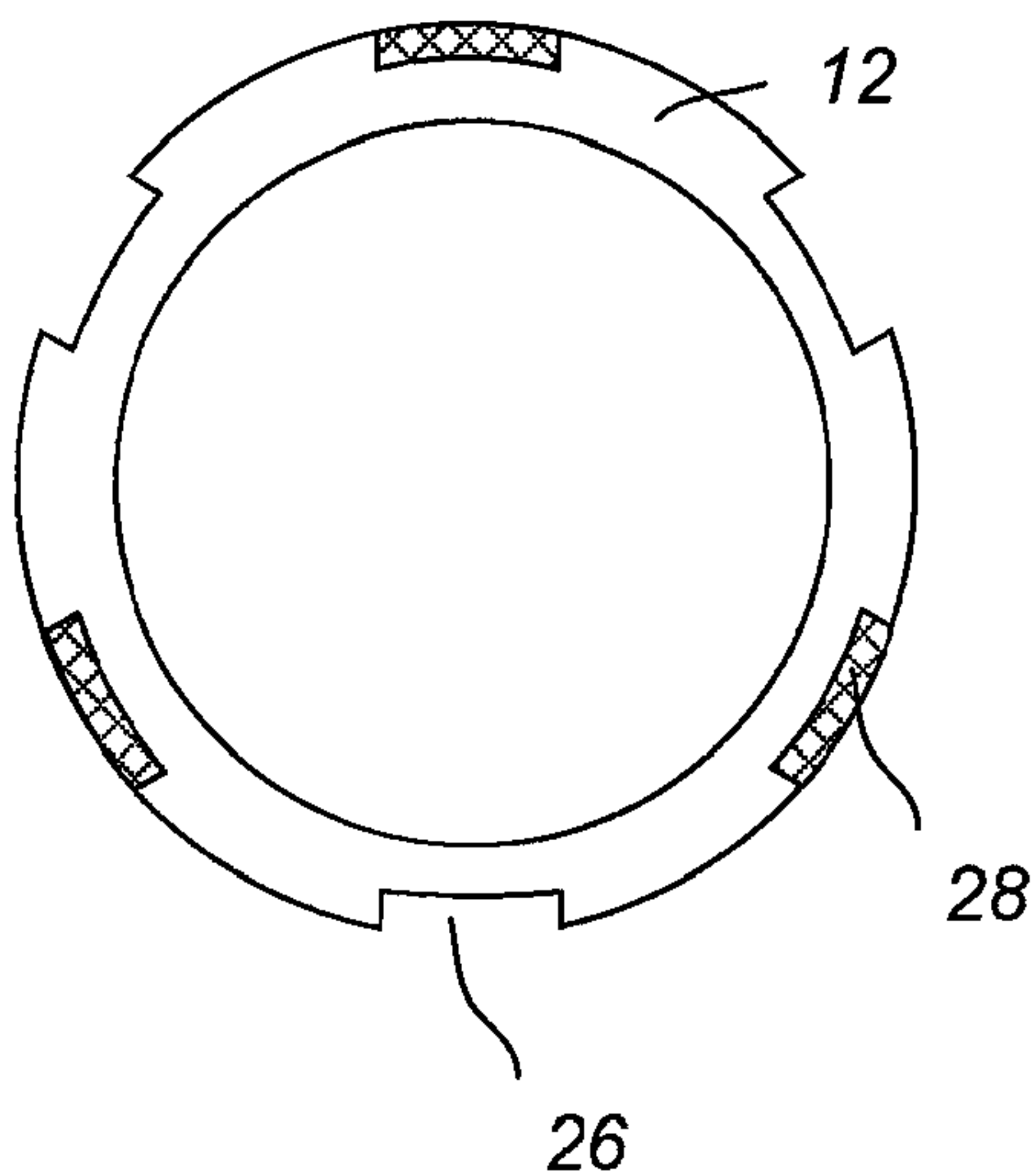

(57) Abstract: Medical balloons are energetically treated to form regions that facilitate deflation to a desirable configuration.

WO 2008/060750 A3

MEDICAL BALLOON DEFLATION

TECHNICAL FIELD

[0001] This invention relates to medical balloon deflation.

BACKGROUND

[0002] The body includes various passageways such as arteries, other blood vessels, and other body lumens. These passageways sometimes become occluded, e.g., by a tumor or restricted by plaque. To widen an occluded body vessel, balloon catheters can be used, e.g., in angioplasty.

[0003] A balloon catheter can include an inflatable and deflatable balloon carried by a long and narrow catheter body. The balloon is initially folded around the catheter body to reduce the radial profile of the balloon catheter for easy insertion into the body.

[0004] During use, the folded balloon can be delivered to a target location in the vessel, e.g., a portion occluded by plaque, by threading the balloon catheter over a guide wire emplaced in the vessel. The balloon is then inflated, e.g., by introducing a fluid into the interior of the balloon. Inflating the balloon can radially expand the vessel so that the vessel can permit an increased rate of blood flow. After use, the balloon is deflated and withdrawn from the body. It is desirable that upon deflation, the balloon forms a predictable low profile configuration that facilitates withdrawal from the body.

SUMMARY

[0005] In an aspect, a method of making an inflatable medical balloon is described. The method includes providing a generally cylindrical inflatable balloon wall or balloon parison formed of polymer, forming a series of first ablated regions wherein the polymer is removed to enhance flexibility of the wall, forming a series of second treated regions alternating with the first ablated regions, the second treated regions being formed by UV radiation exposure, heating, or ion implantation, such that the second treated regions have less flexibility than the first ablated regions.

[0006] In another aspect, a method of making an inflatable medical balloon is described. The method includes providing a generally cylindrical inflatable balloon

wall or balloon parison formed of polymer and forming a series of first treated regions where the polymer crystallinity is increased, but no polymer is removed from the balloon in the first treated regions, wherein upon deflation the balloon folds according to the locations of the series of first treated regions.

[0007] In another aspect, an inflatable medical balloon device is described. The device includes a generally cylindrical balloon wall formed of polymer. The wall includes a series of first ablated regions where polymer has been removed to enhance flexibility and a series of second treated regions alternating with the ablated regions, and third regions. The second treated regions having a flexibility less than the ablated regions but more flexibility than the third regions of the balloon.

[0008] In an aspect, a medical device including an inflatable balloon having a generally cylindrical wall formed of polymer is described. The wall includes a series of first treated regions where the crystallinity of the polymer is greater compared to the crystallinity of the polymer in a series of second regions formed of the polymer, the first treated regions having a flexibility different than the second regions, wherein the balloon device upon deflation folds according to the locations of the first treated locations.

[0009] In an aspect, a medical device including an inflatable balloon having a generally cylindrical wall formed of polymer is described. The wall includes a series of ablated groove regions. The groove regions have grooves with a depth of between about 1-2% of a thickness of the wall and the groove regions have at least about 4% greater polymer crystallinity than polymer regions outside the grooved regions.

[00010] In an aspect, the invention features a method including providing a medical device as described herein, arranging the balloon into lobes and wrapping the lobes, delivering the balloon into the body, inflating the balloon, and deflating the balloon, whereby the balloon forms at least three lobes.

[00011] In an aspect, a medical device including an inflatable balloon having a generally cylindrical wall formed of polymer is described. The wall has a series of ablated groove regions, the groove regions having grooves with a depth of between about 1-2% of a thickness of the wall and the groove regions having at least about 4% greater polymer crystallinity than polymer regions outside the grooved regions.

[00012] In an aspect, a medical device including an inflatable balloon having a generally cylindrical wall formed of polymer is described. The wall has a series of

regions having at least about 4% greater polymer crystallinity than polymer areas outside the regions, wherein the surface of the balloon in the regions has raised nodules of polymer that cause the polymer areas outside the regions to have a greater effective thickness than the regions.

[00013] Embodiments may include one or more of the following advantages. A balloon can be formed that folds after inflation into a desired configuration which has a low profile that facilitates withdrawal from the vessel after angioplasty and/or stent delivery. Balloons treated using two or more different processes can enhance the precision and reliability of balloon folding. The processes can be used to define regions of different flexibility in a desired pattern to induce a desired fold profile. The different processes can employ different techniques such as laser ablation, hot stick, CO₂ laser, and ion beam treatment which can induce different effects to the balloon material, such as material removal, cross-linking, and carbonization.

[00014] Still further aspects, features and advantages follow.

DESCRIPTION OF DRAWINGS

[00015] FIGS. 1A -1C are partial cross-sectional views illustrating delivery of a stent in a collapsed state over a balloon, expansion of the stent by inflation of the balloon, and deflation and withdrawal of the balloon;

[00016] FIGS. 2A -2C are end on cross-sectional views of a balloon in conditions corresponding to FIGS. 1A -1C.

[00017] FIG. 3A is a side view of a balloon in an inflated state;

[00018] FIG. 3B is a cross-sectional view through the wall of the balloon in FIG. 3A;

[00019] FIG. 3C is a cross-sectional view similar to FIG. 3B with the balloon in a refolded deflated state.

[00020] FIG. 4A is a schematic of the balloon during a first treatment process;

[00021] FIG. 4B is a schematic of the balloon in FIG. 4A undergoing a second treatment process.

[00022] FIG. 5A is a schematic of the balloon treated with first and second treatment processes;

[00023] FIG. 5B is a schematic of the balloon a folded state.

[00024] FIG. 6 is a scanning electron microscope image of a modified surface.

- [00025] FIG. 7A is a schematic side view of an inflated balloon with one type of treated region;
- [00026] FIG. 7B is a schematic end view of an inflated balloon with one type of treated region.
- [00027] FIG. 8A is a schematic side view of an inflated balloon with one type of treated region;
- [00028] FIG. 8B is a schematic end view of an inflated balloon with one type of treated region.
- [00029] Like reference symbols in the various drawings indicate like elements.

DETAILED DESCRIPTION

[00030] Referring to FIGS. 1A-1C, stent 10 is placed over a balloon 12 carried near a distal end of a catheter 14, and is directed through a lumen 16, e.g., a blood vessel such as the coronary artery, until the portion carrying the balloon and stent reaches the region of an occlusion 18 (FIG. 1A). The stent 10 is then radially expanded by inflating the balloon 12, and is pressed against the vessel wall with the result that occlusion 18 is compressed, and the vessel wall surrounding it undergoes a radial expansion (FIG. 1B). The pressure is then released from the balloon and the catheter is withdrawn from the vessel (FIG. 1C).

[00031] Referring as well to FIGS. 2A-2C, during delivery to the treatment site, the balloon is in a folded condition in which the balloon material is arranged into three flaps or lobes 20, 22, 24 and the lobes are wrapped around the catheter body to provide a low profile (FIG. 2A). During inflation, inflation fluid is introduced into the balloon and the lobes unwrap such that at full inflation the balloon forms a substantially circular cross section of a diameter sufficient to carry out the desired treatment, such as an angioplasty and/or stent delivery procedure (FIG. 2B). After full expansion, the inflation fluid is withdrawn from the balloon and the balloon forms three lobes (FIG. 2C). Forming two or more lobes, such as three, four, five, six, seven or more lobes, on deflation reduces the profile of the balloon which facilitates withdrawal of the balloon by, for example reducing the likelihood of snagging the stent and minimizing friction or abrasion with the body lumen.

[00032] Referring as well to FIGS. 3A-3C, the formation of a desired lobe configuration is facilitated by treating the balloon wall to modify its chemical and/or mechanical properties, such as its stiffness or flexural strength, in different ways in

different regions. Referring particularly to FIGS. 3A and 3B, the balloon 12 has two series of modified regions 26, 28 which alternate with one another and with regions of unmodified balloon material. The regions 26, 28 have been treated by different processes so that their properties differ from each other. Referring as well to FIG. 3C, in the embodiment illustrated, the regions 26 have been modified so that, upon balloon deflation, they form the valleys between lobes and the regions 28 form the apexes of the lobes.

[00033] Referring to FIGS. 4A and 4B, the regions 26, 28 are formed by separate processes of ablating and modifying crystallinity of the balloon material. To both ablate and increase the crystallinity of the material, regions 26, 28 of the balloon are exposed to ultraviolet radiation. Referring to FIG. 4A, the regions 26 are exposed to an ultraviolet radiation from a laser 30 controlled by a controller 32 to deliver energy to the exposed regions such that the laser fluence exceeds the ablation threshold of the material. Chemical bonds are broken and the material is fractured into energetic fragments which leave the ablation zone. It is theorized that most of the energy is deposited in the ejected material so there is little thermal damage to surrounding materials. The high energy input to regions 26 removes some of the thickness of the material and therefore reduces the stiffness of these regions more than regions exposed to lower total energy or the unmodified polymer. As a result, the more flexible regions 26 tend to fold and collapse more quickly as the balloon is deflated, forming valleys. Referring to FIG. 4B, the regions 28 are formed by exposure of ultraviolet radiation at a lower fluence, that is below the ablation threshold. The regions 28 that are treated with the lower energy have increased crystallinity, which increases the stiffness or modulus of these regions. The increased stiffness causes the treated regions to be less flexible than the unmodified regions and thus the balloon is less likely to bend in the stiffer regions than in the unmodified regions. The stiffer regions 28 form the apexes of the lobes upon refolding. The balloon thus has three regions, where each of the three regions has a different flexibility due to different amount of material thickness or crystallinity in each region.

[00034] Exposure to UV radiation can increase the crystallinity of the polymer and/or ablate or remove polymeric material. If the balloon is ablated, the amount of material removed can be for example, about 0.1-15%, such as 0.5 to 2.5% of the balloon wall thickness. If the balloon's crystallinity is modified without substantial

ablation effects, the crystallinity of the polymer can be increased by about 2 to 90%, e.g., 2-5%, 5-10%, 10-20%, 20-40%, 40-60%, 60-70%, 70-80%, 80-90% or 20-80%, compared to the unmodified polymer. In some embodiments, the crystallinity percentage can be two, three or four times after modification than prior to modification. The amount of crystallinity and/or material removal can be selected to finely tailor the balloon refolding properties. Whether material is removed or not is dependent on the fluence of the laser and the material from which the balloon is formed. The amount of change in crystallinity can be controlled by controlling the energy delivered to the exposed regions, such as by controlling the time of exposure, the fluence and/or the wavelength of radiation. Crystallinity can be increased by increasing the exposure time at a low fluence. A suitable laser is a multigas UV excimer laser at a wavelength of about 193 nm. Ultraviolet ablation is further described in U.S. 4,911,711. Suitable ablation and control systems are available from Coherent Lambda Physik, in Goettingen, Germany. Crystallinity can be measured by WAX/SAX x-ray diffraction. Crystallinity measurements can be made at various vendors, such as the University of Minnesota Shepard characterization lab.

[00035] Referring as well to FIGS. 5A and 5B, in other embodiments regions 34, 36 can be formed by using different modification techniques. The regions 34, 36 are each regions with increased crystallinity, but one region 34 has greater crystallinity than the other region 36. The region 34 with the greatest crystallinity forms the apex of the fold when the balloon is collapsed. The region 36 with somewhat increased crystallinity, that is the region where the crystallinity is greater than the unmodified balloon material but less than the region 34 with the greatest crystallinity, tends to fold into the valleys between the lobes of the collapsed balloon.

[00036] As an alternative to treating the balloon with two different treatment methods, a balloon can be treated with only one treatment method that increases crystallinity without substantially removing material from the surface of the balloon, that is, without ablation. The thickness of the balloon in the treated and untreated regions can be substantially the same. Crystallinity can be increased by heating the polymer material to between the glass transition temperature and the melt flow temperature. Within this temperature range, crystals begin to form or crystals that were previously present grow larger. Crystallinity can be changed only on the surface or can be changed throughout the depth of the balloon wall.

[00037] Suitable techniques for inputting heat into the balloon, such as UV lasers, affect primarily the surface of the balloon. For example, a UV laser may penetrate only part way into a polymer surface, such as 1-60 Angstroms into the balloon. Other heating techniques can penetrate more deeply into the material. With
5 some methods of applying energy, the energy not only penetrates into the material, but radiates isotropically. This heating is considered to be massive or bulk heating of the material, because more than just the surface of the material is heated. A laser, such as a CO₂ laser, an IR laser, a YAG laser, a diode laser or any another suitable photon source, a heat stick, i.e., a conductive material connected to a heat cartridge, or an RF
10 generator can be used to apply heat to the balloon. In the case of an RF generator, a jelly having metal particles can be applied to the regions to be treated. If a laser is used to apply heat to the balloon, the balloon can be filled with a fluid to absorb the heat and prevent other portions of the balloon from being simultaneously treated. As noted herein, the amount of crystallinity can be controlled, such as by controlling the amount
15 of time that energy is input into the balloon or controlling the energy output by the energy input device. To focus the heat on particular regions of the balloon, a mask can be used or the device for applying the heat can be focused only in the region where crystallization is desired. With some methods of treating the balloon, the depth of the crystallization can determine whether the treated region ends up on the apex or the
20 valley of a fold. Surface treatment with a UV laser tends to form treated regions that are in the valleys of the folds of the balloon, where treatment with a CO₂ laser or hot stick forms treated regions that are on the apex of the folds a balloon.

[00038] Flexibility or stiffness variations can also be formed by other techniques, such as ion beam exposure and mechanically by cutting regions of the
25 balloon wall. All of these techniques can be used in any combination to provide desired properties to the balloon. Ion beam treatment is further described in U.S. Patent No. 7,963,942, and U.S. Patent Application Publication No. 2007-0191923. The treated regions can be formed by application of energy on the balloon directly or on a polymer tubular parison that is subsequently formed or blown into a balloon, e.g.
30 by free inflation or blow molding. Balloon formation is described further in U.S. 4,963,313.

[00039] Polymers suitable for forming the balloon include biaxially oriented polymers, thermoplastic elastomers, engineering thermoplastic elastomers,

polyethylenes, polyethylene terephthalate (PET), polybutylenes, polyamides (e.g. nylon 66), polyether block amides (e.g., PEBAX®), polypropylene (PP), polystyrene (PS), polyvinyl chlorides (PVC), polytetrafluorethylene (PTFE), polymethylmethacrylate (PMMA), polyimide, polycarbonate (PC), polyisoprene rubber (PI), nitrile rubbers, silicone rubbers, ethylene-propylene diene rubbers (EPDM), butyl rubbers (BR), thermoplastic polyurethanes (PU) (e.g., those based on a glycol ether and an isocyanate, such as PELLETHANE®). In particular embodiments, a poly(ether-amide) block copolymer having the general formula

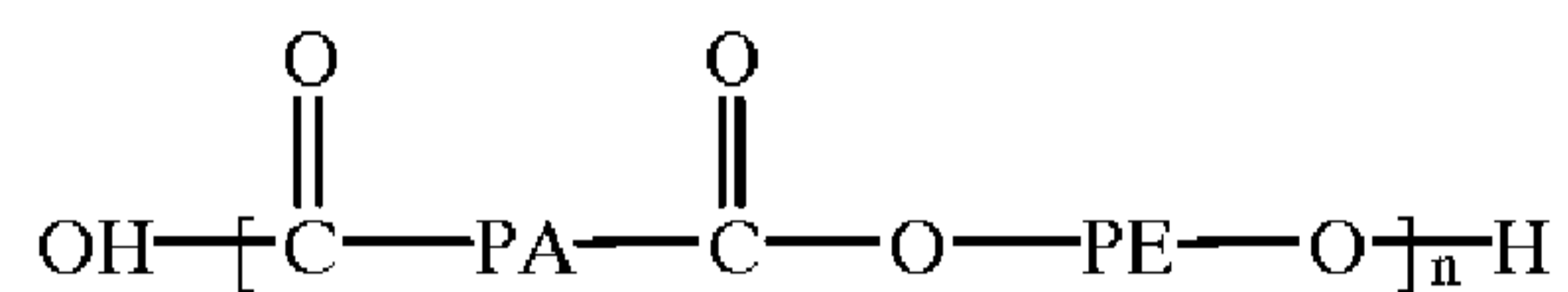

in which PA represents a polyamide segment, e.g., nylon 12, and PE represents a polyether segment, e.g., poly(tetramethylene glycol) is utilized. Such polymers are commercially available from ARKEMA under the tradename PEBAX®. The balloon can be formed of single polymer or of multiple polymers, e.g. by coextrusion.

[00040] As noted above, the fluence threshold depends on the balloon material and on the type of wavelength of energy input into the material. Suitable UV lasers for treating the balloon have a wavelength between about 150-450 nm, such as 157, 193, 248, 308 or 351 nm. For treating a PET or a PEBAX® balloon with a 193 nm laser, less than about 150 mJ/cm², such as between about 60-70 mJ/cm² will avoid ablating the balloon material. Other combinations of materials and lasers will have different thresholds of fluence to avoid ablation.

[00041] In addition to the linear treated regions described, the treated regions can be arranged in other configurations to enhance refolding. In some embodiments, the treated regions spiral around the balloon. In some embodiments the treated regions are only on the cones, only on the body or both on the body and the cones of the balloon. In yet other embodiments the treated regions are not formed in a contiguous line, but are formed as a series of dots, dashes or shapes which together determine where the balloon will fold upon deflation.

[00042] Balloons can be treated to facilitate formation of two or more, preferably three or four or more lobes. The lobes that form when the balloon is deflated after use in a lumen can form at locations corresponding to the locations of the lobes formed and wrapped for delivery or the lobes can form at different locations

on deflation. When the balloon is able to collapse into a multilobed profile, the diameter of the collapsed balloon is less than when the balloon flattens or pancakes. This smaller profile can facilitate in removing the collapsed balloon from a lumen, such as a stent or vessel. That is, the folded balloon can be smoothly removed from the lumen with less risk of sticking or catching on the lumen on removal. Any number of treated regions can be formed on the surface of the balloon, such as four, five, six, seven or eight treated regions. The balloons can be used in vascular and nonvascular applications, including coronary, peripheral, carotid, esophageal or urethral applications.

Example

[00043] A 3.0x16 mm TAXUS® Liberté™ OTW (PEBAX® 7233) polymer balloon available from Boston Scientific, Natick, MA, is inflated to a pressure of 2 psi and exposed to UV radiation using a Lambda 210i, multigas UV excimer laser (available from Coherent Lambda Physik, in Goettingen, Germany) operating at a pulse duration of 29 ns and at a wavelength of 193 nm with an attenuator set at 30 VA to deliver a fluence of 30 mJ/cm², which is below the ablation threshold of PEBAX®, which is around 60-70 mJ/cm². The beam from the laser is about 1 mm wide and about 5 mm long. Three linear regions approximately 1 mm in width spaced equidistantly about the balloon are exposed. The regions are exposed at a shot spacing of 400 microns. The exposed regions became opaque and have a crystallinity of about 22%, where the untreated regions has a crystallinity of about 16%.

[00044] Referring to FIG. 6, an effect of some heat applications, such as application of UV laser, is to rearrange material at the surface of the balloon. A magnified view of a balloon surface that is crystallized using a UV laser shows nodules 52. The balloon is a TAXUS® Liberté™ OTW (PEBAX® 7233) polymer balloon available from Boston Scientific, Natick, MA, and is exposed to UV radiation using a Lambda 210i, multigas UV excimer laser (available from Coherent Lambda Physik, in Goettingen, Germany) operating at a wavelength of 193 nm with an attenuator set at 30 VA to achieve an output of 30 mJ/cm². Forming the nodules 52 does not remove polymer material from the balloon wall, but rearranges the material on the balloon surface and can reduce the effective wall thickness between the nodules. A non-treated balloon wall would appear smooth and free of nodules. Nodules 52 are observed when the balloon is treated with a UV laser, but are not

observed with other treatments, such as CO₂ laser or hot stick. The UV laser treated regions also appear to be opaque, due to the surface modification.

[00045] Referring to FIG. 7A, a treated balloon has three stripes 62 made using UV laser. All stripes extend past the balloon body-cone transition area on both the 5 distal and proximal ends. Each stripe has 1 mm width. Referring to FIG. 7B, the end view shows the three treated regions on the cone of the balloon. Referring to FIGS. 8A and 8B, the folded balloon forms three lobes. The profile of the tri-folded balloon is about 30% less than when compared to a pancaked balloon, or a balloon that has not been treated and flattens rather than folds when deflated. When a 3.0 x 16 mm 10 TAXUS® Liberté™ OTW balloon is treated in regions to enhance refolding, the refolding profile was found to be 2.85 mm. A similar balloon that is not treated pancakes to have a profile of 4.16 mm.

[00046] Still further embodiments are in the following claims.

**THE EMBODIMENTS OF THE INVENTION IN WHICH AN EXCLUSIVE
PROPERTY OR PRIVILEGE IS CLAIMED ARE DEFINED AS FOLLOWS:**

1. A method of making an inflatable medical balloon, comprising:
5 providing a tubular inflatable balloon or balloon parison formed of polymer,
forming a series of first series regions wherein polymer is removed to enhance
flexibility, and
forming a series of second treated regions by UV radiation exposure, heating,
or ion implantation, such that the second treated regions have less flexibility than the
10 first treated regions,
wherein, the first treated regions and second treated regions alternate radially
about the balloon, or the first treated regions and the second treated regions alternate
with untreated regions radially about the balloon so that upon deflation the balloon
folds at the locations of the series of second treated regions to form apexes of lobes.
15
2. The method of claim 1, wherein forming the second treated regions includes
increasing the crystallinity in the second treated regions without removing polymer.
3. The method of claim 1, comprising forming the first treated regions and second
20 treated regions by exposure to UV radiation.
4. The method of claim 3, comprising controlling the laser fluence to ablate
polymer in the first regions and to increase the polymer crystallinity in the second
treated regions.
25
5. The method of claim 1, comprising forming the second treated regions by
heating.
6. The method of claim 5, comprising heating by exposure to infrared radiation.
30
7. The method of claim 5, comprising heating by direct exposure to a heat source.
8. The method of claim 1, comprising forming said second treated regions by ion
beam exposure.

9. A method of making an inflatable medical balloon, comprising:
providing a tubular inflatable balloon or balloon parison formed of polymer,
forming a series of first treated regions where the polymer crystallinity is
5 increased without removing polymer from the balloon, and
forming a series of second treated regions having a different crystallinity than
the first treated regions, where the first treated regions and second treated regions
alternate radially about the balloon, or the first treated regions and the second treated
regions alternate with untreated regions radially about the balloon so that upon
10 deflation the balloon folds according to the locations of the series of first treated
regions to form apexes or valleys of lobes.
10. The method of claim 9, comprising the forming the first and second regions by
laser irradiation, direct heat application or ion implantation.
- 15 11. The method of claim 10, comprising forming the first treated and second
regions by UV laser irradiation.
12. The method of claim 9, comprising forming said first and second regions
20 without removing polymer.
13. An inflatable medical balloon device, comprising:
a cylindrical balloon wall formed of polymer wherein the wall includes a series
of first ablated regions where polymer has been removed and a series of second treated
25 regions alternating with the ablated regions, and third regions, the second treated
regions having a flexibility less than the ablated regions but more flexibility than the
third regions of the balloon, wherein the first through third regions alternate radially
about the balloon so that upon deflation the balloon folds at the locations of the series
of second treated regions to form valleys of lobes.
- 30 14. The device of claim 13, wherein second treated regions are ablated regions in
which less material is removed than the first ablated regions.
15. The device of claim 13, wherein the second treated regions are regions of

increased crystallinity compared to the third regions.

16. An inflatable medical balloon device, comprising:
a cylindrical balloon wall formed of polymer wherein the wall includes a series
5 of first treated regions where the crystallinity of the polymer is greater compared to the
crystallinity of the polymer in a series of second regions formed of the polymer, the
first treated regions having a flexibility different than the second regions, wherein the
first treated regions and second regions alternate radially about the balloon, or the first
treated regions and the second regions alternate with untreated regions radially about
10 the balloon so that upon deflation the balloon device folds at the locations of the first
treated locations to form valleys of lobes.
17. The balloon device of claim 16, wherein the first treated regions and the second
regions have the same thickness.
- 15 18. The balloon device of claim 16, wherein the balloon forms three or more lobes
on deflation.
19. The balloon device of claim 16, including a stent positioned over the balloon.
- 20 20. The balloon device of claim 16, wherein the first treated regions have a
crystallinity that is at least twice the crytallinity of the second regions.
21. The balloon device of claim 16, wherein the first treated regions have a surface
25 with polymer nodules.
22. The balloon device of claim 16, further comprising third treated regions
alternating with the first treated regions and the second regions, the second regions
having a flexibility less than the first treated regions and greater than the third treated
30 regions.
23. The balloon device of claim 22, wherein the third treated regions are at the
apex of lobes formed upon deflation.

24. The balloon device of claim 22, wherein the third treated regions are ablated regions and have a thickness less than the thickness of the balloon wall in the second regions.

5 25. A medical device, comprising:

an inflatable balloon having a tubular wall formed of polymer, the wall including a series of ablated groove regions, the groove regions having grooves with a depth of between about 1-2% of a thickness of the wall and the grooves regions having at least about 4% greater polymer crystallinity than polymer regions outside the
10 grooved regions, and second treated regions having flexibility less than the groove regions, wherein the groove regions and the second treated regions alternate radially about the balloon, or the groove regions and the second treated regions alternate with polymer regions other than the groove regions and the second treated regions radially about the balloon so that upon deflation the balloon folds at the locations of the
15 grooved regions to form valleys of lobes.

26. The medical device of claim 25, wherein the balloon forms three or more lobes on deflation.

20 27. A method of manufacturing a medical device, comprising providing a medical device according to claim 25, arranging the balloon into lobes and wrapping the lobes, whereby the balloon forms at least three lobes.

25 28. A medical device, comprising:

an inflatable balloon having a cylindrical wall formed of polymer, the wall including a series of regions having at least 4% greater polymer crystallinity than polymer areas outside the regions, wherein the surface of the balloon in the regions has raised nodules of polymer, wherein the series of regions and the polymer areas outside
30 the regions radially alternate about the balloon so that upon deflation the balloon folds at the locations of the series of regions to form apexes of lobes.

29. A method of making an inflatable medical balloon forming two or more lobes on deflation, which method comprises:

providing a generally tubular inflatable balloon or balloon parison formed of polymer,

forming a series of first series regions wherein polymer is removed to enhance flexibility, and

5 forming a series of second treated regions by UV radiation exposure, heating, or ion implantation, such that the second treated regions have less flexibility than the first treated regions, wherein the first treated regions and second treated regions alternate radially about the balloon and the first treated regions and the second treated regions alternate with untreated regions radially about the balloon, such that,

10 upon balloon deflation, the first series regions form valleys between lobes and the second treated regions form apexes of the lobes, characterized by forming the second treated regions includes increasing the crystallinity in the second treated regions without substantially removing polymer.

15 30. The method of claim 29, comprising forming the first treated regions and second treated regions by exposure to UV radiation.

20 31. The method of claim 30, comprising controlling the laser fluence to ablate polymer in the first regions and to increase the polymer crystallinity in the second treated regions.

32. The method of claim 29, comprising forming the second treated regions by heating.

25 33. The method of claim 32, comprising heating by exposure to infrared radiation.

34. The method of claim 33, comprising heating by direct exposure to a heat source.

30 35. The method of claim 29, comprising forming said second treated regions by ion beam exposure.

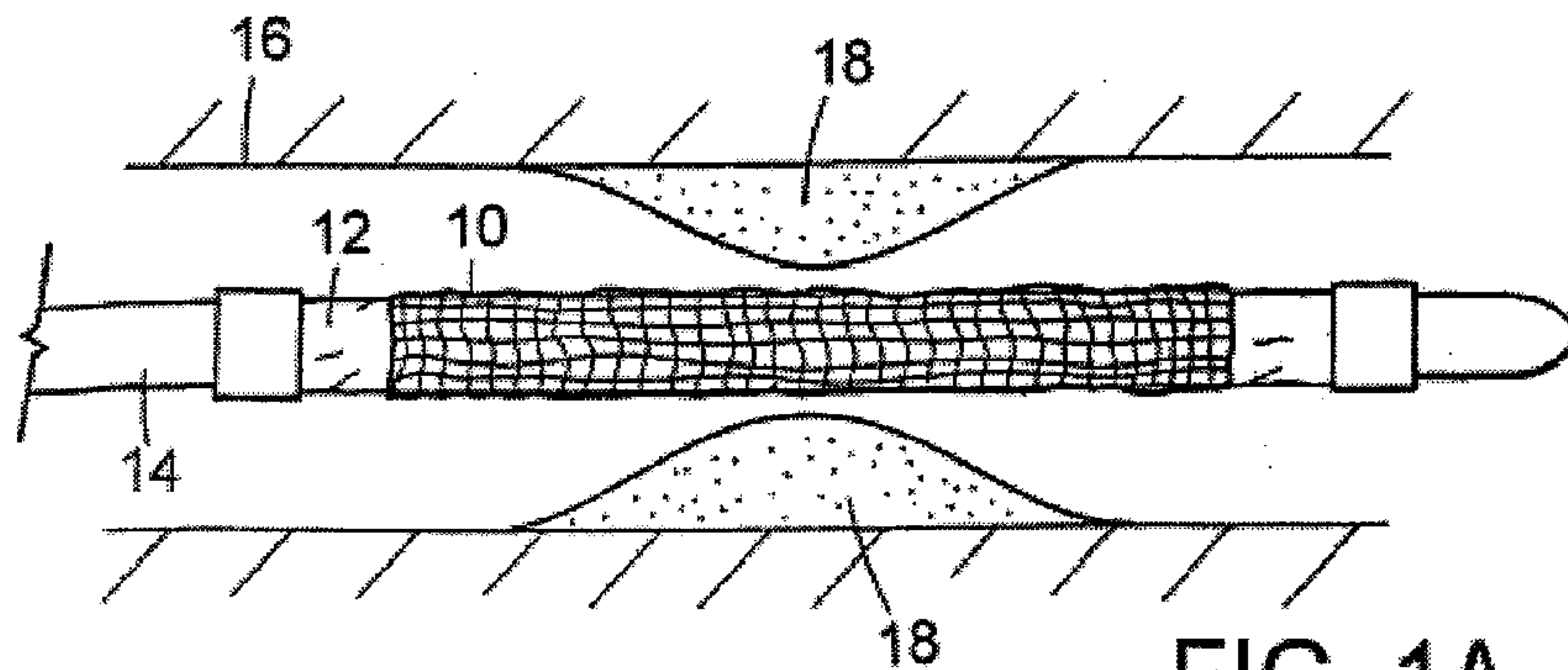

FIG. 1A

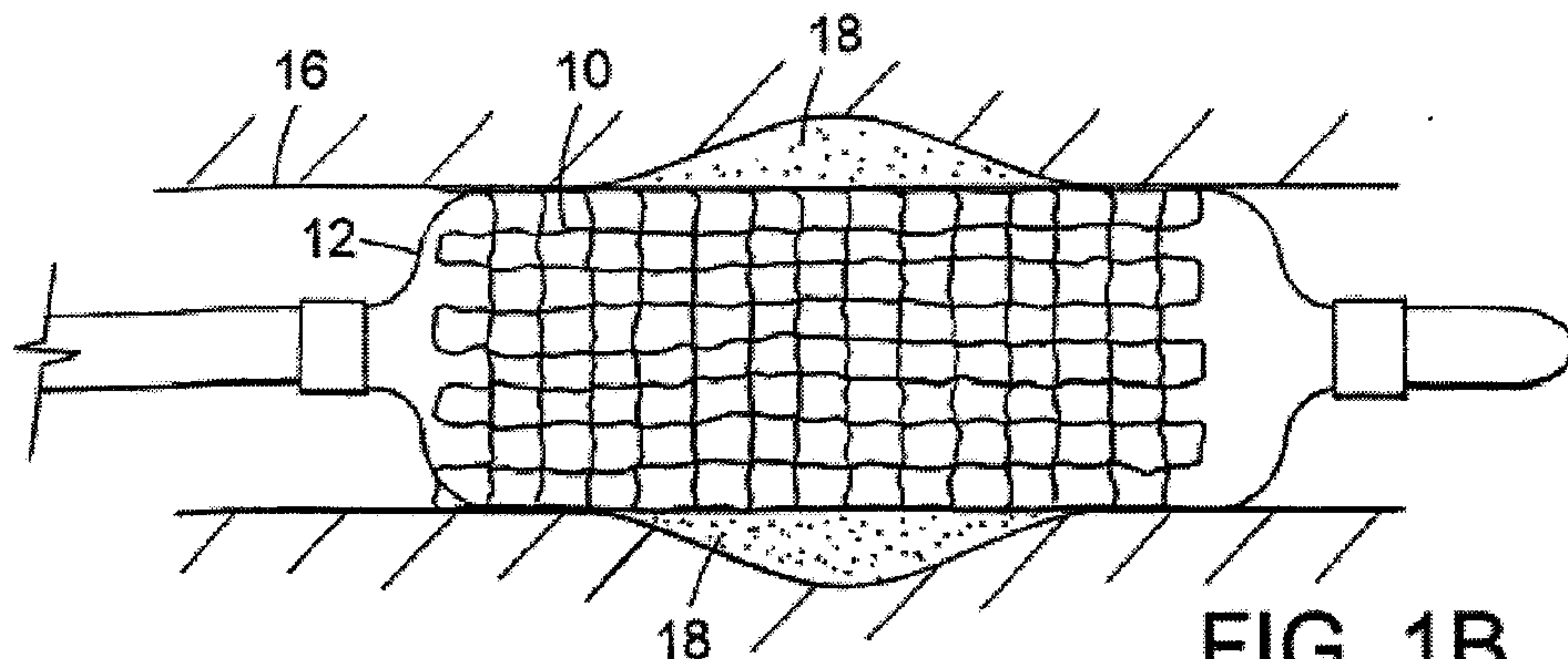

FIG. 1B

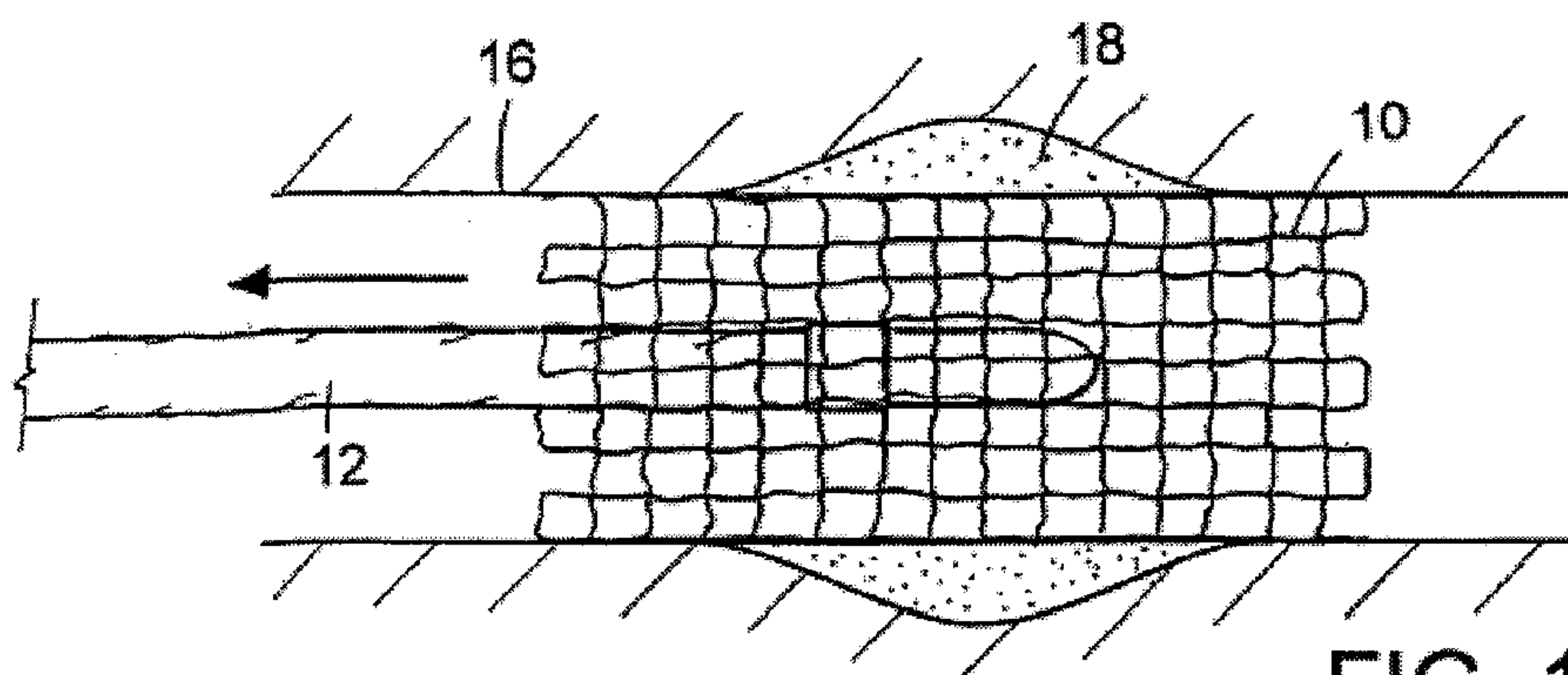

FIG. 1C

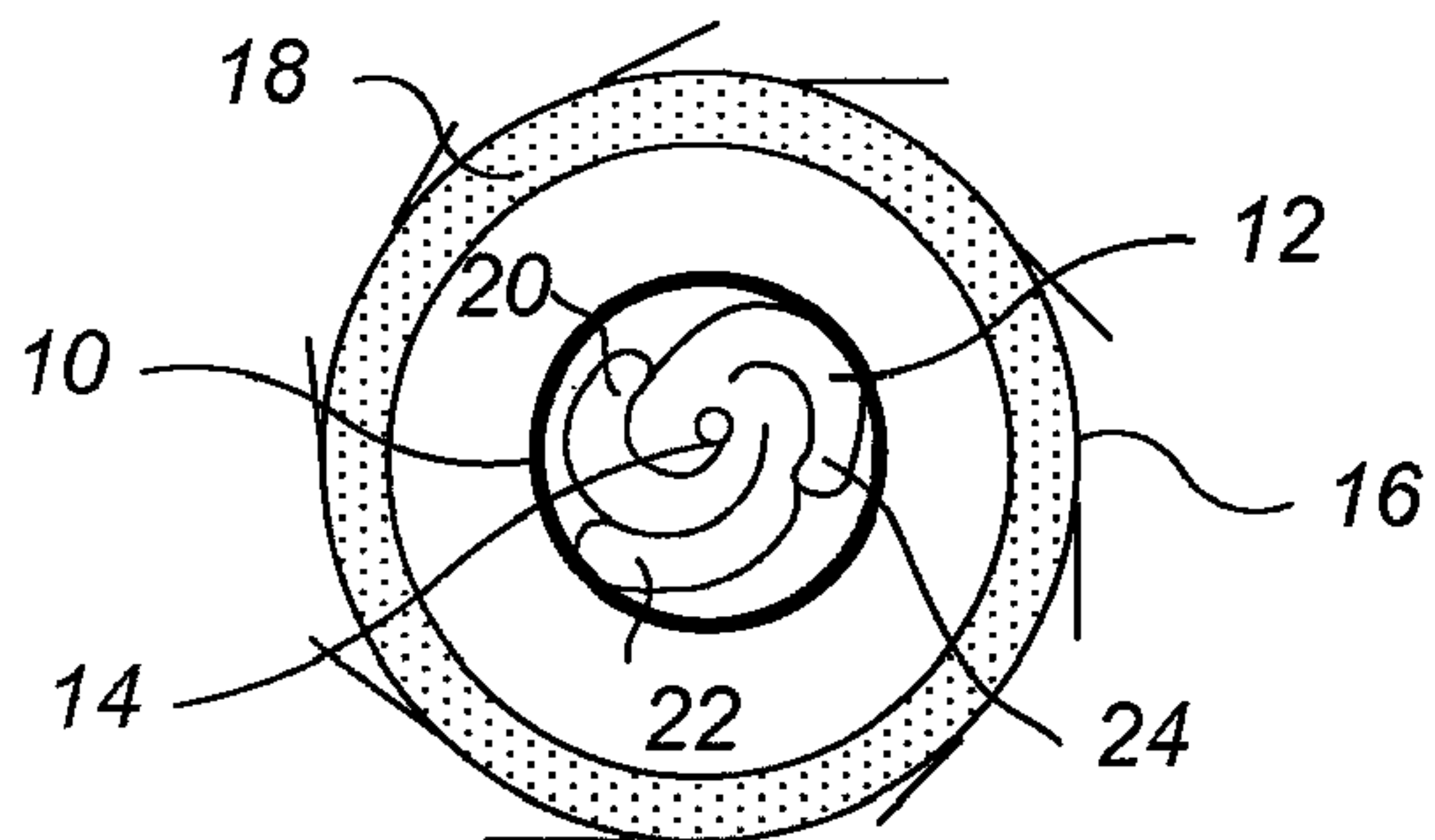

FIG. 2A

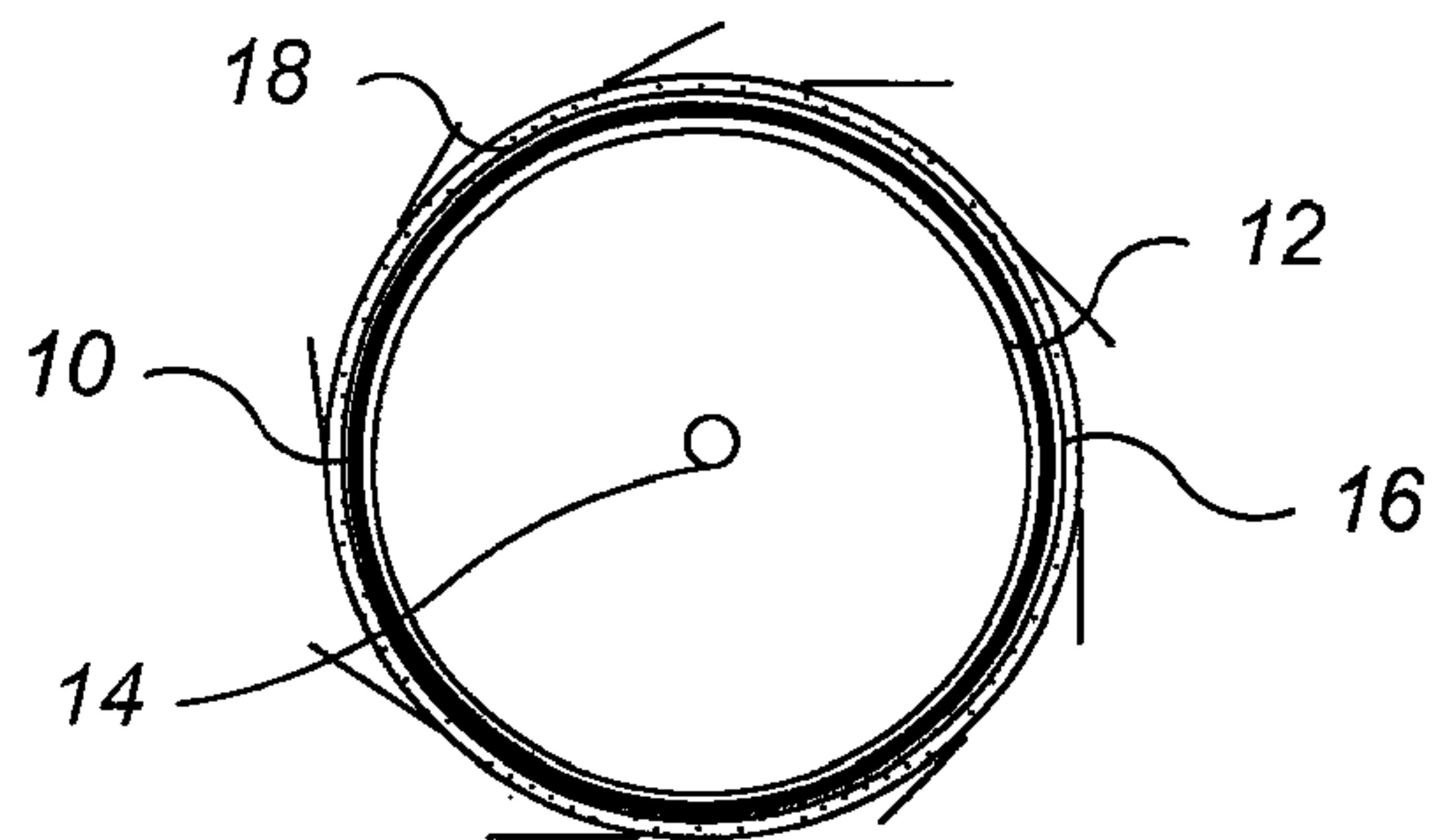

FIG. 2B

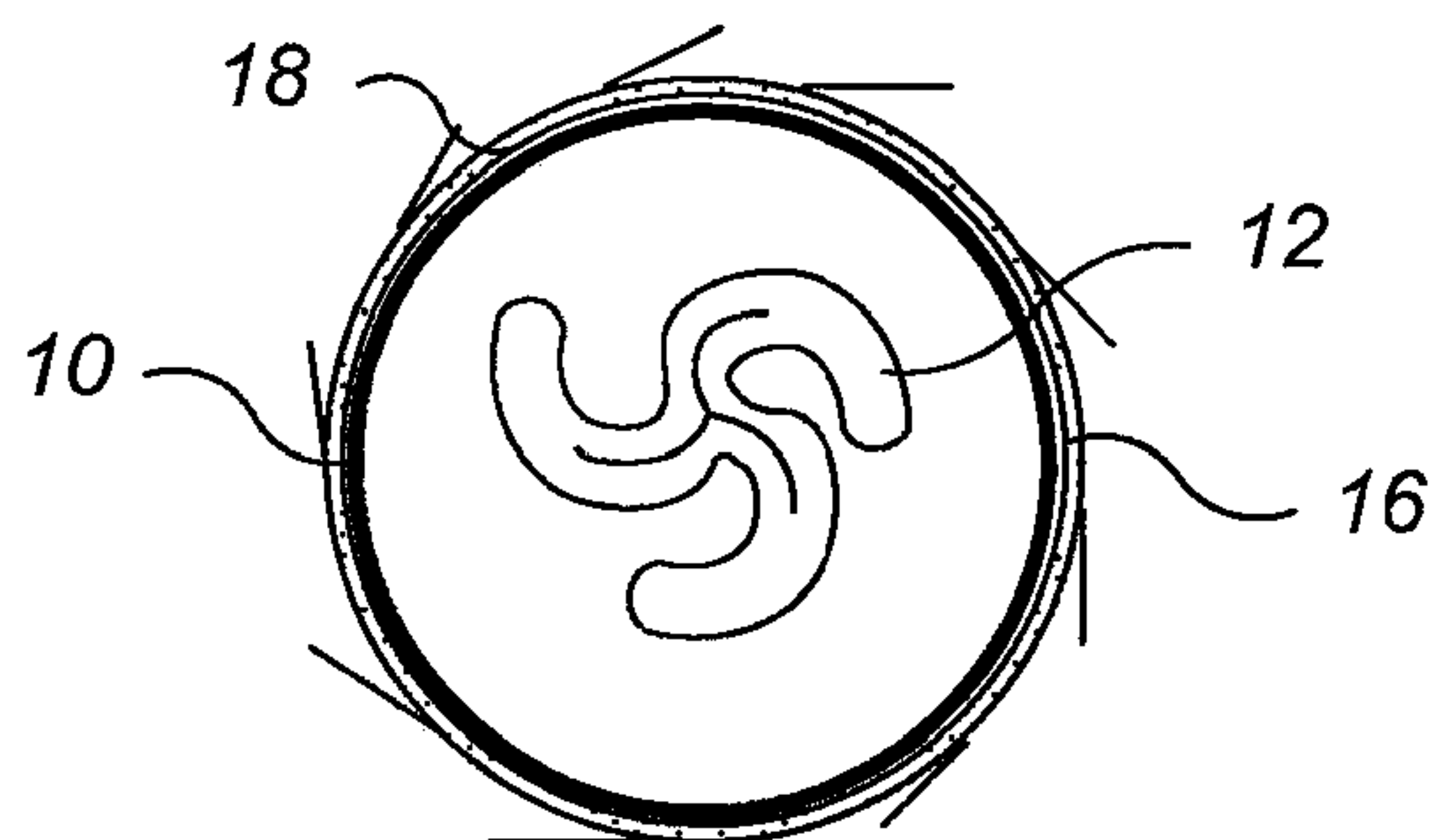

FIG. 2C

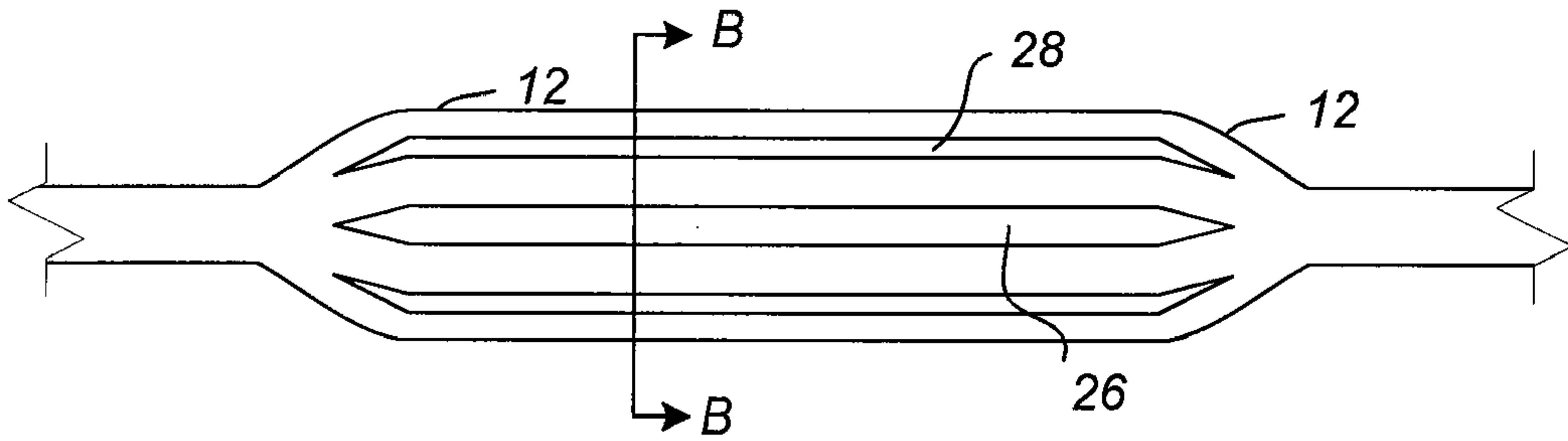

FIG. 3A

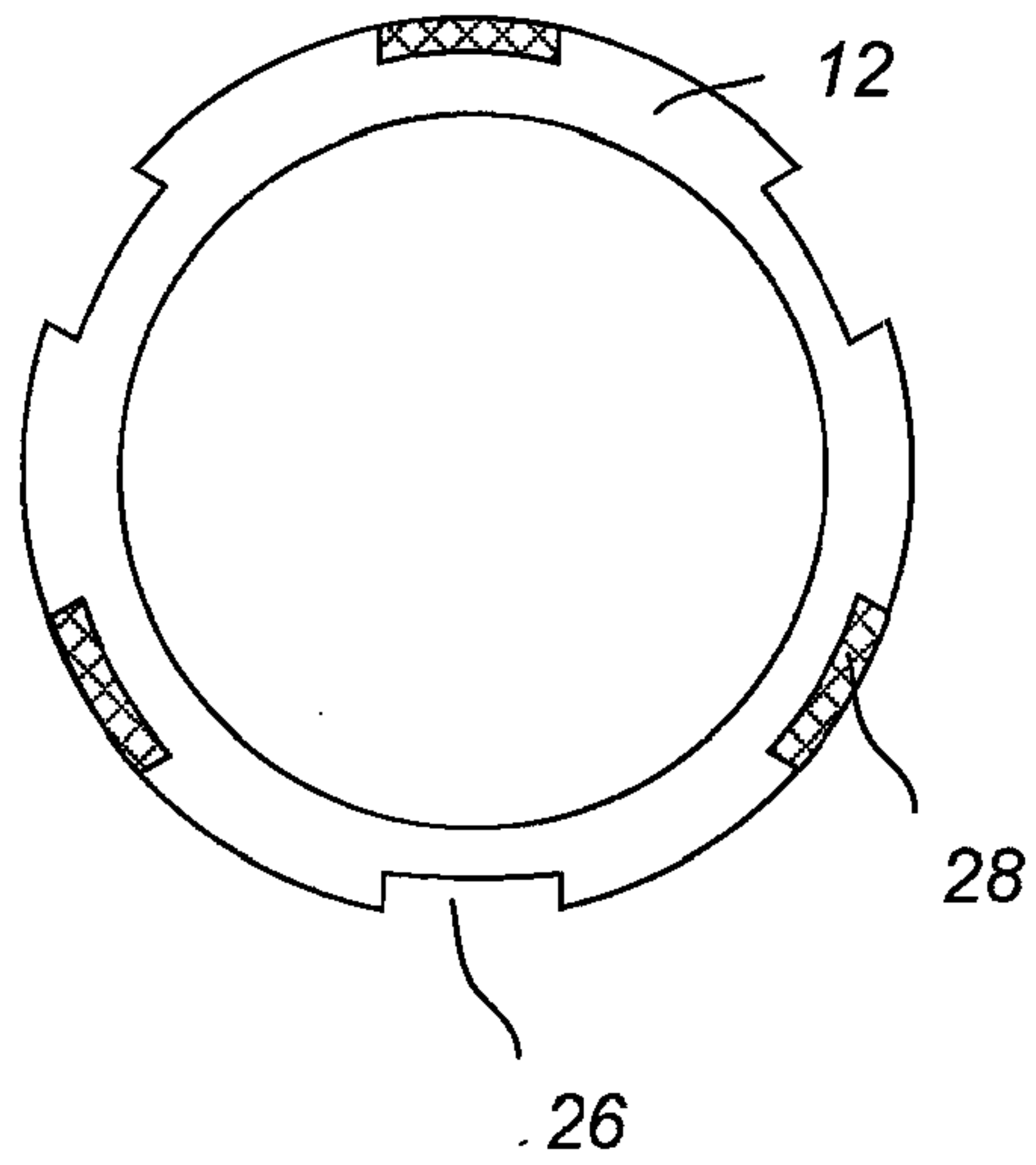

FIG. 3B

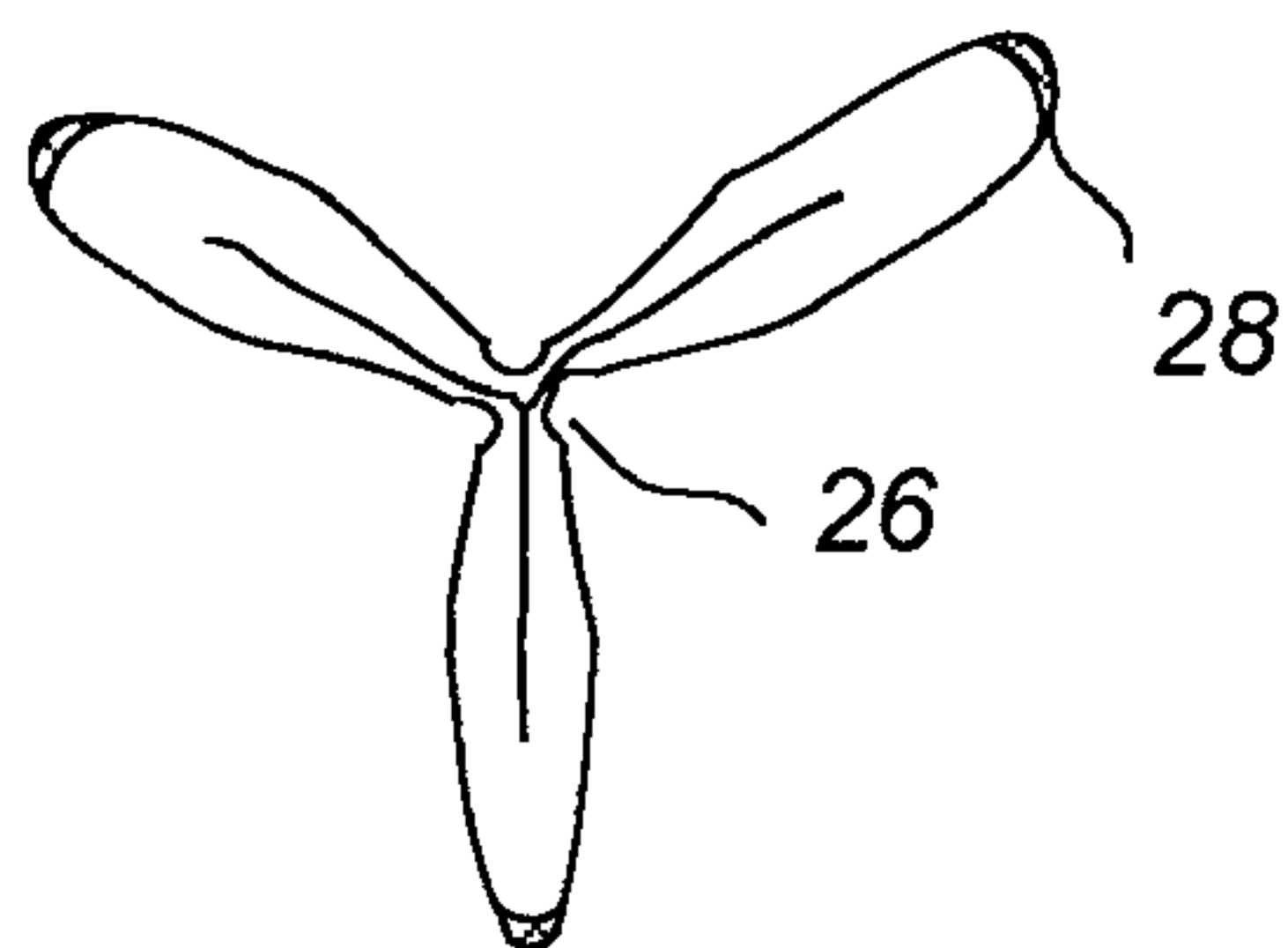

FIG. 3C

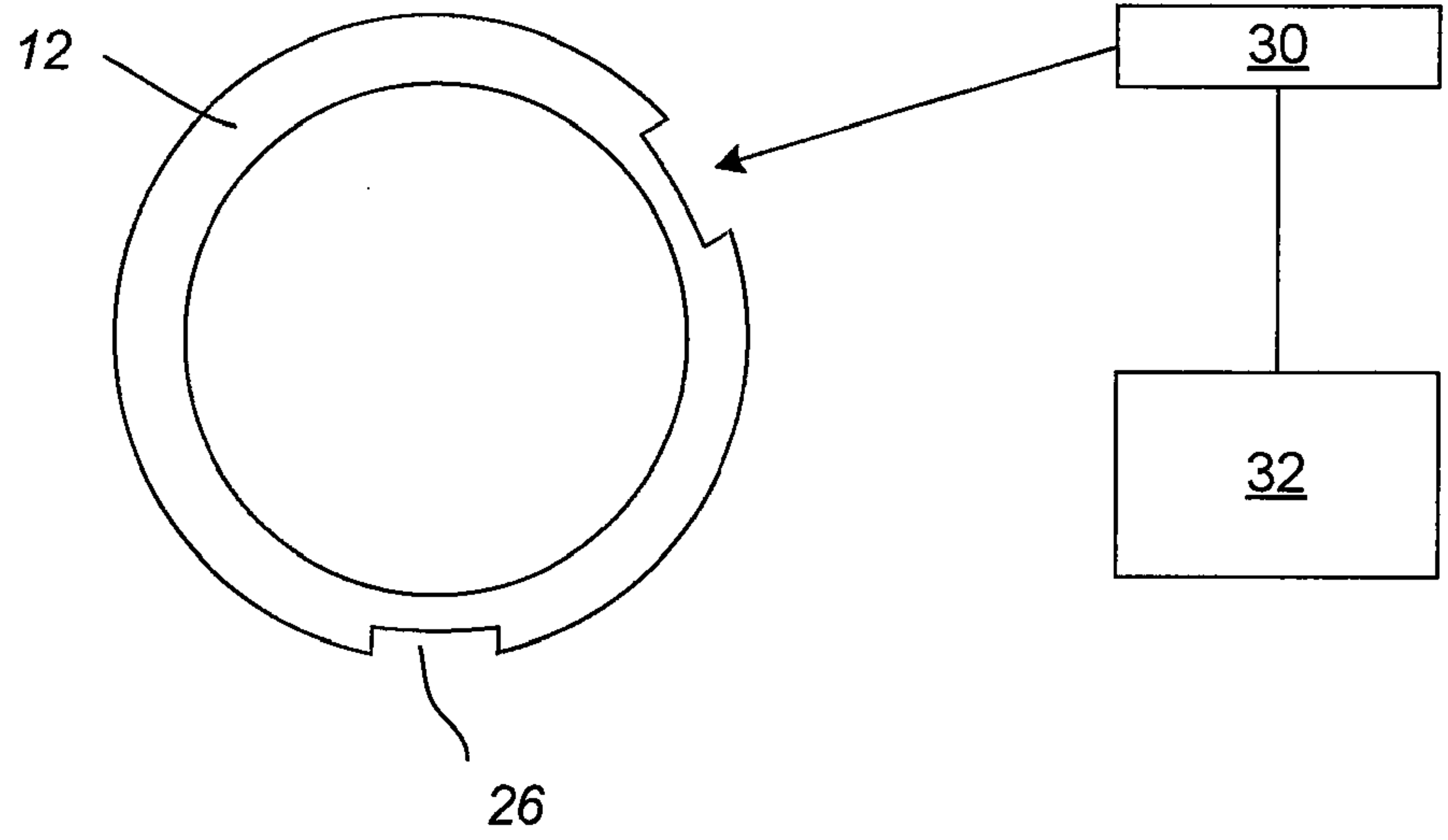

FIG. 4A

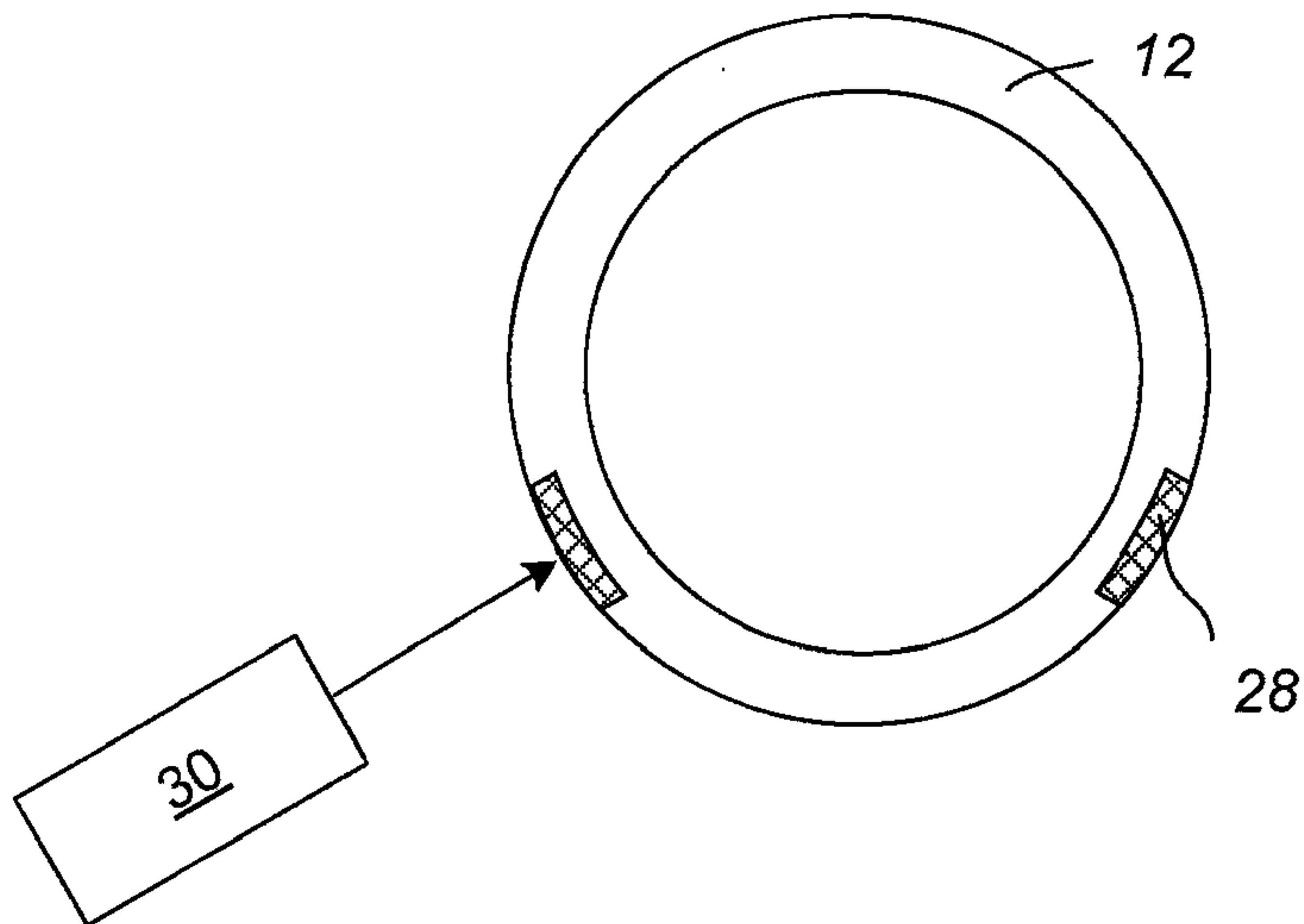

FIG. 4B

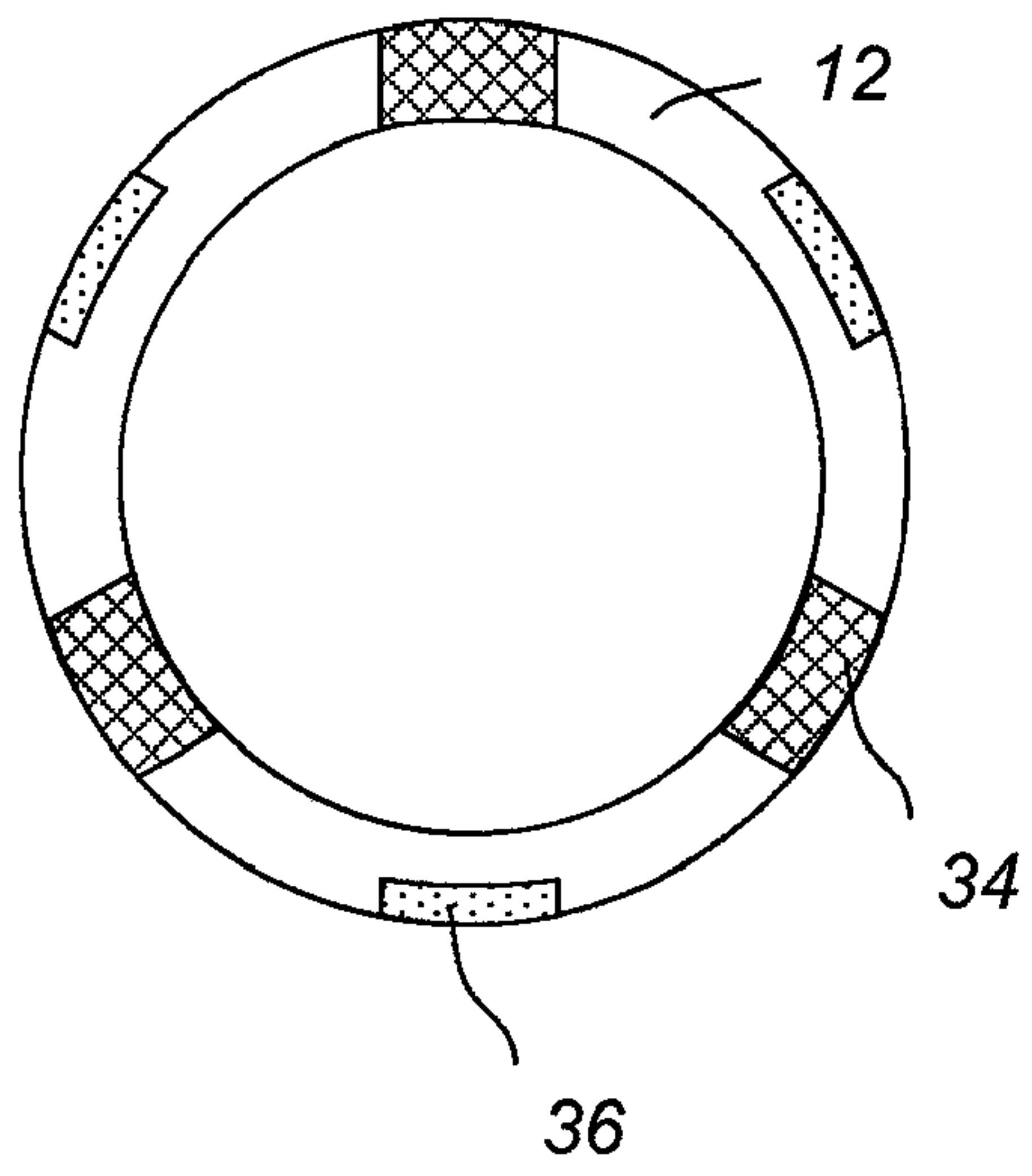

FIG. 5A

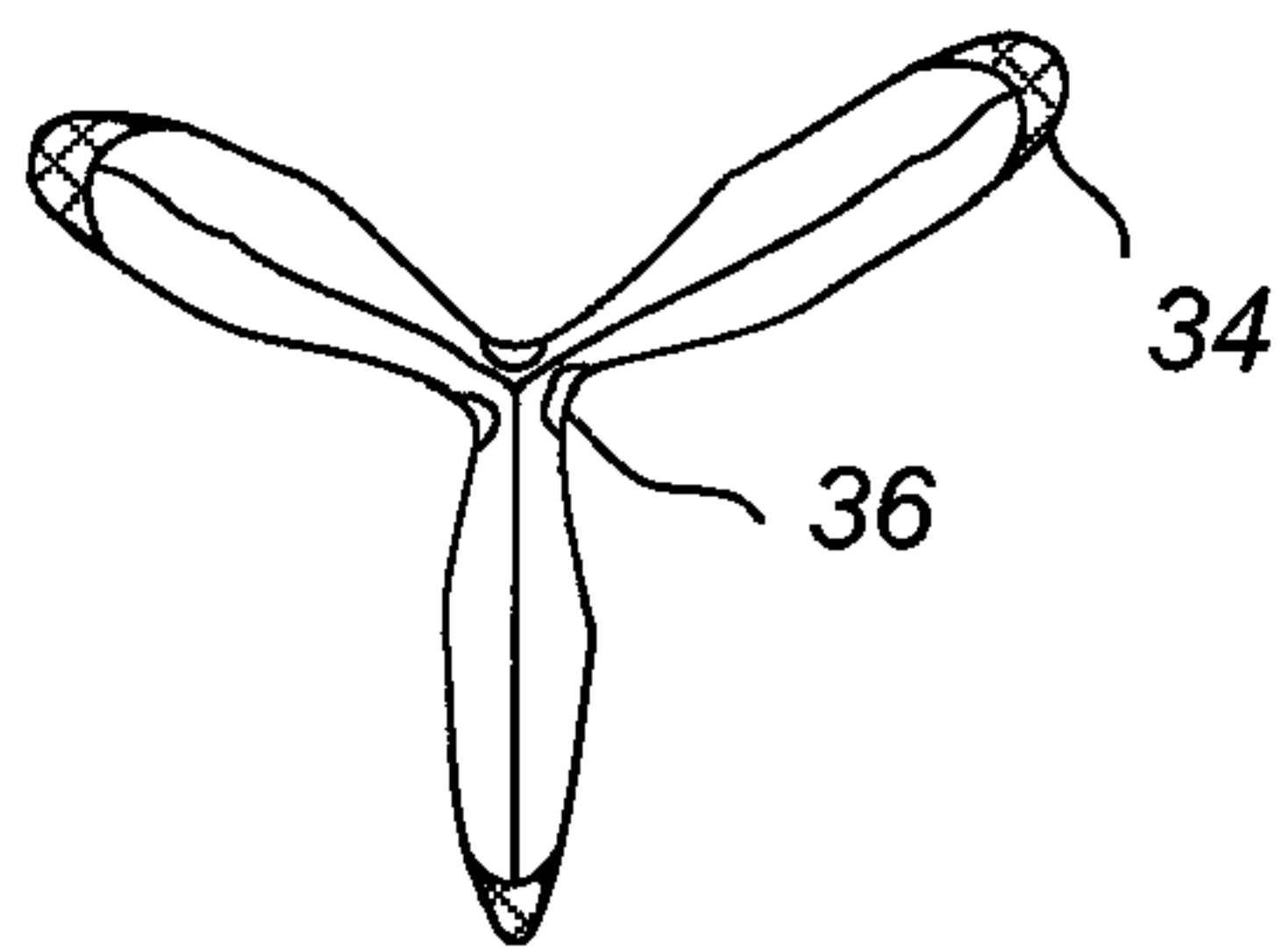

FIG. 5B

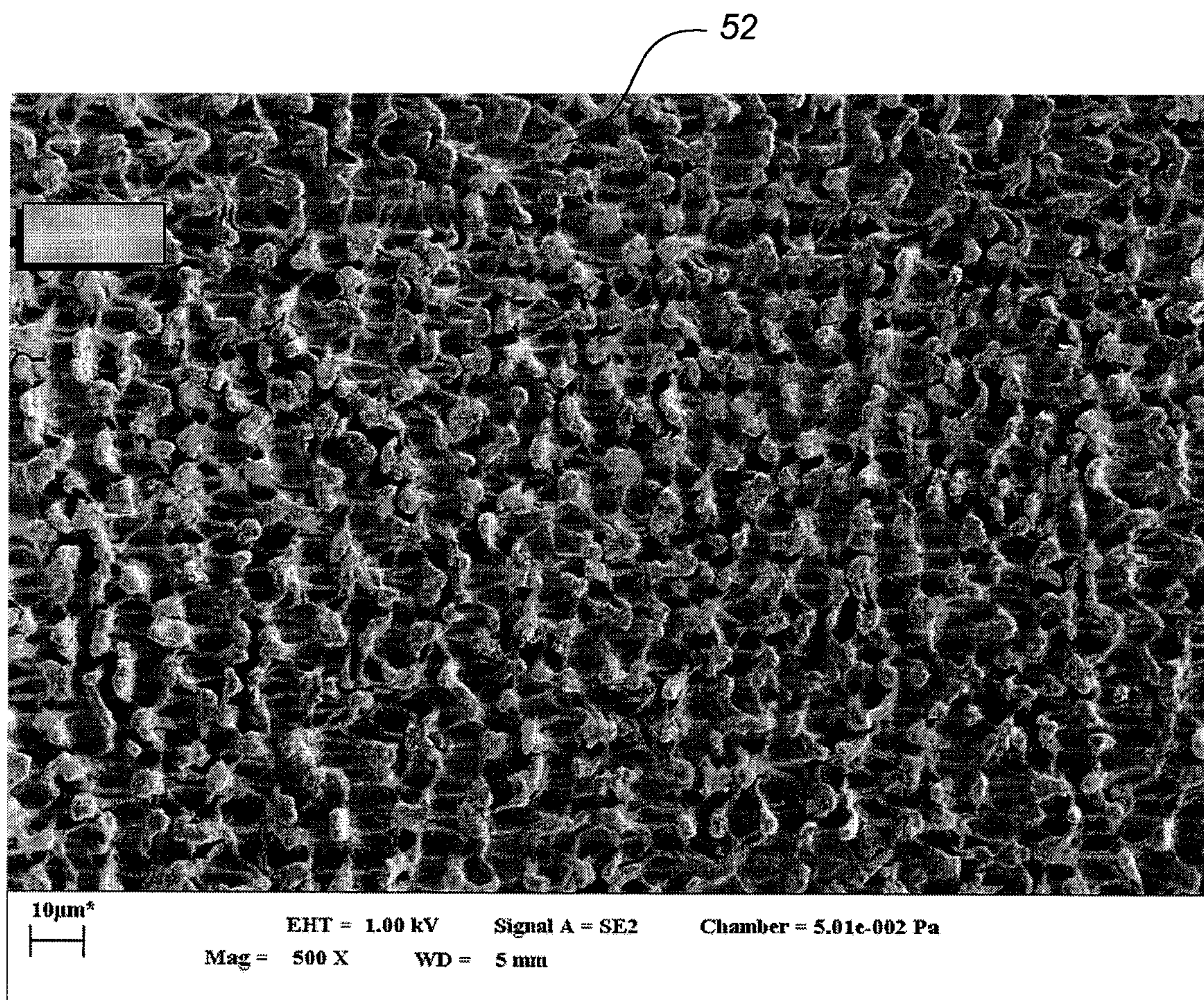

FIG. 6

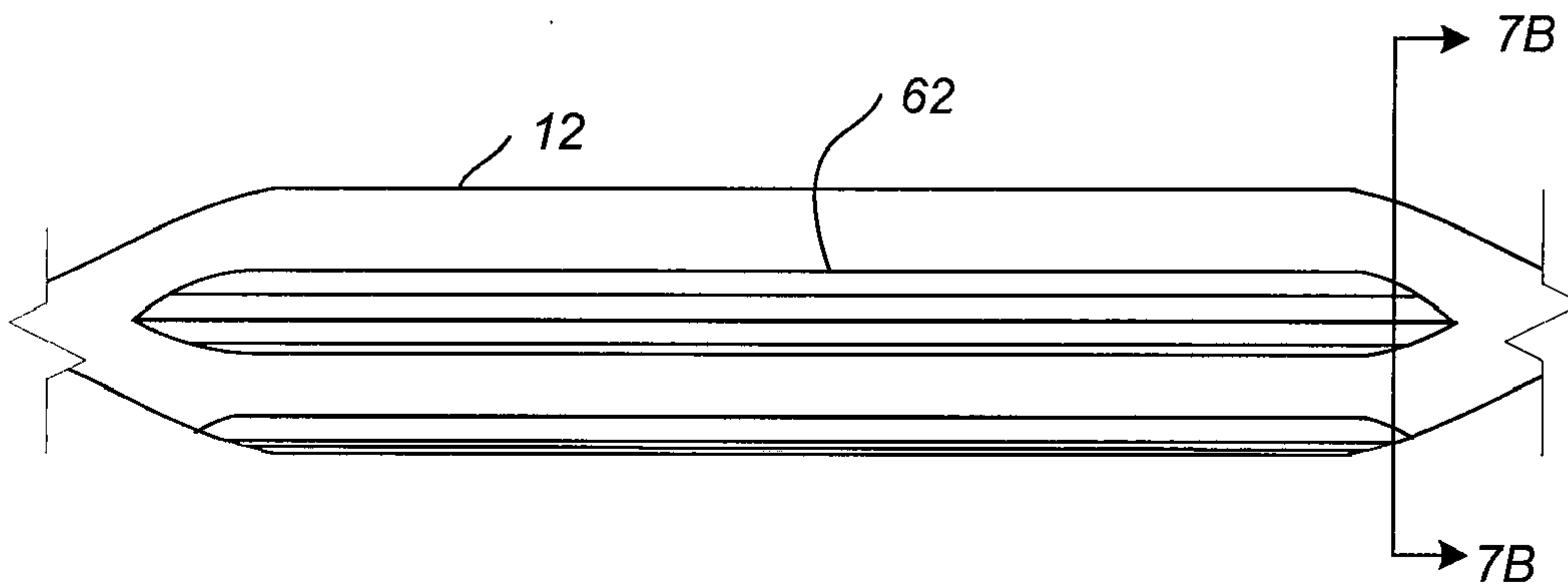

FIG. 7A

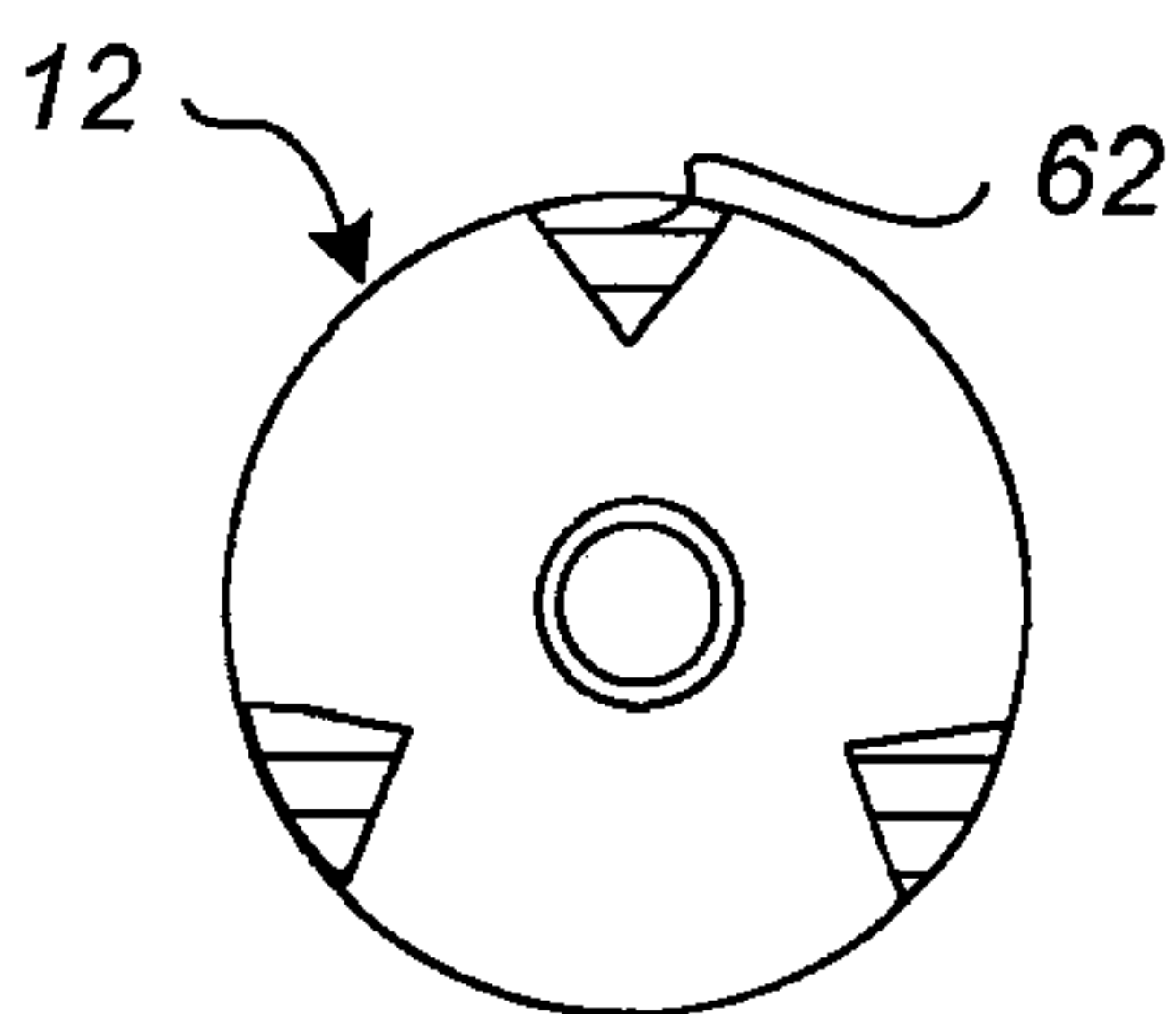

FIG. 7B

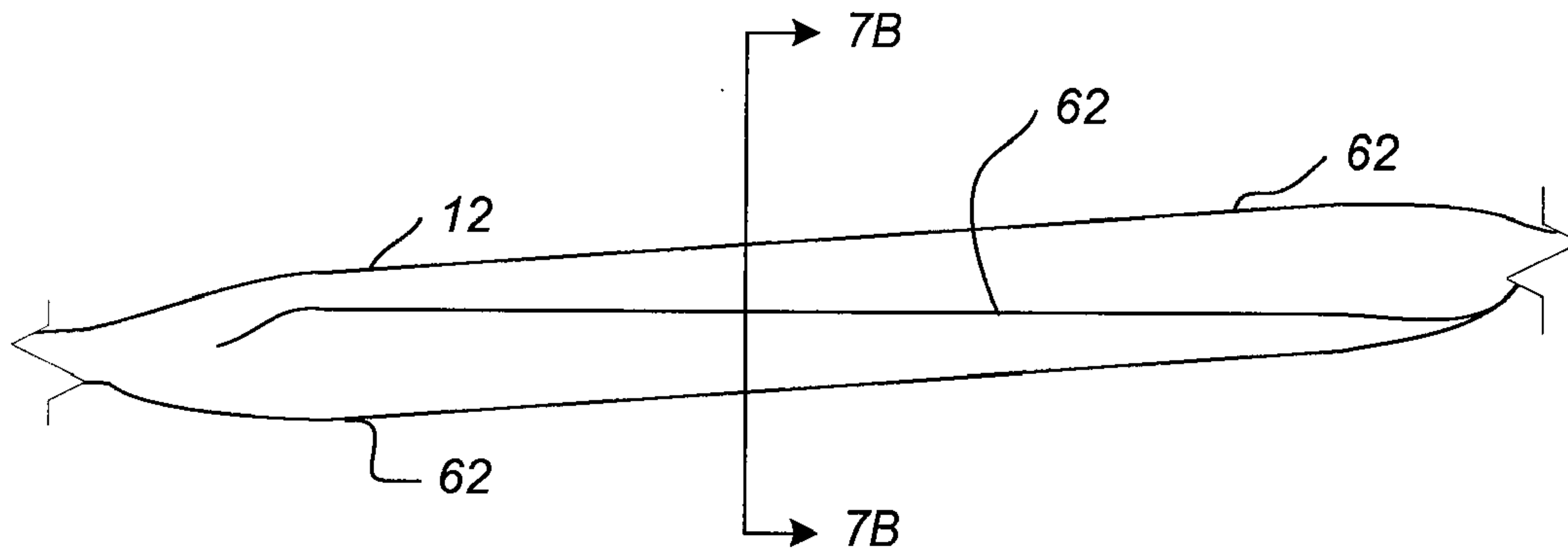

FIG. 8A

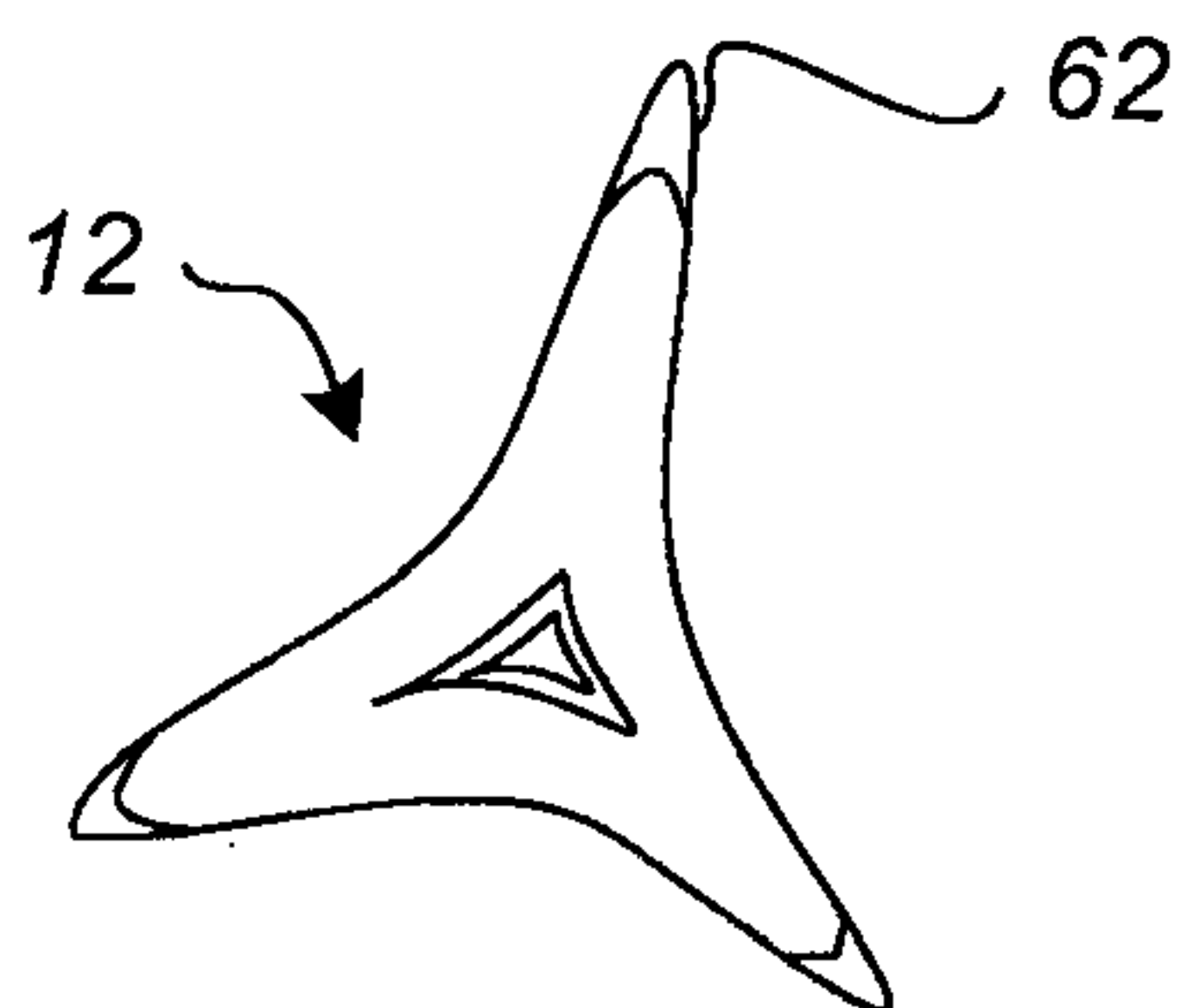

FIG. 8B

