



US00D642995S

(12) **United States Design Patent**
Lin et al.

(10) **Patent No.:** **US D642,995 S**

(45) **Date of Patent:** **** Aug. 9, 2011**

(54) **LED LIGHT BAR**

(75) Inventors: **Chih-Yung Lin**, Taipei (TW);
Min-Tsun Hsieh, Taipei (TW);
Ching-Lien Yeh, Taipei (TW); **Chi-Wei Liao**, Taipei (TW); **Lung-Hsin Chen**, Taipei (TW); **Wen-Liang Tseng**, Taipei (TW)

(73) Assignee: **Advanced Optoelectronic Technology, Inc.**, Hsinchu Hsien (TW)

(**) Term: **14 Years**

(21) Appl. No.: **29/375,808**

(22) Filed: **Sep. 28, 2010**

(30) **Foreign Application Priority Data**

Jul. 23, 2010 (CN) 2010 3 0248415

(51) **LOC (9) Cl.** **13-03**

(52) **U.S. Cl.** **D13/180**

(58) **Field of Classification Search** D13/180;
D26/211; 257/79, 80, 81, 88, 89, 95, 98,
257/99, 100, E33.058; 313/483, 498, 500;
362/555, 800

See application file for complete search history.

(56) **References Cited**

U.S. PATENT DOCUMENTS

6,450,663 B1 * 9/2002 Reinbach 362/545
7,220,040 B2 * 5/2007 Lengyel et al. 362/612
D593,045 S * 5/2009 Plonski et al. D13/180
7,637,626 B2 * 12/2009 Park et al. 362/97.3

7,674,009 B2 * 3/2010 Chang 362/249.02
D616,383 S * 5/2010 Peifer D13/180
D616,384 S * 5/2010 Chan et al. D13/180
D622,676 S * 8/2010 Yasuoka et al. D13/180
7,780,312 B2 * 8/2010 Han et al. 362/235
7,794,098 B2 * 9/2010 Chang 362/97.3
D628,541 S * 12/2010 Lin D13/180
2005/0157500 A1 * 7/2005 Chen et al. 362/294
2007/0030674 A1 * 2/2007 Kim et al. 362/231
2007/0217192 A1 * 9/2007 Hiratsuka 362/241

* cited by examiner

Primary Examiner — Selina Sikder

(74) *Attorney, Agent, or Firm* — Raymond J. Chew

(57) **CLAIM**

The ornamental design for an LED light bar, as shown and described.

DESCRIPTION

FIG. 1 is a perspective view of an LED light bar showing our new design, the LED light bar being separated into several parts due to its very long length.

FIG. 2 is a front elevational view thereof.

FIG. 3 is a rear elevational view thereof.

FIG. 4 is an enlarged left-side, elevational view thereof, an enlarged right-side, elevational view being a mirror image of FIG. 3.

FIG. 5 is a top plan view thereof.

FIG. 6 is a bottom plan view thereof.

FIG. 7 is an enlarged view of a circled portion VII of FIG. 1.

FIG. 8 is an enlarged view of a circled portion VIII of FIG. 2.

FIG. 9 is an enlarged view of a circled portion IX of FIG. 5; and,

FIG. 10 is an enlarged view of a circled portion X of FIG. 6.

1 Claim, 10 Drawing Sheets

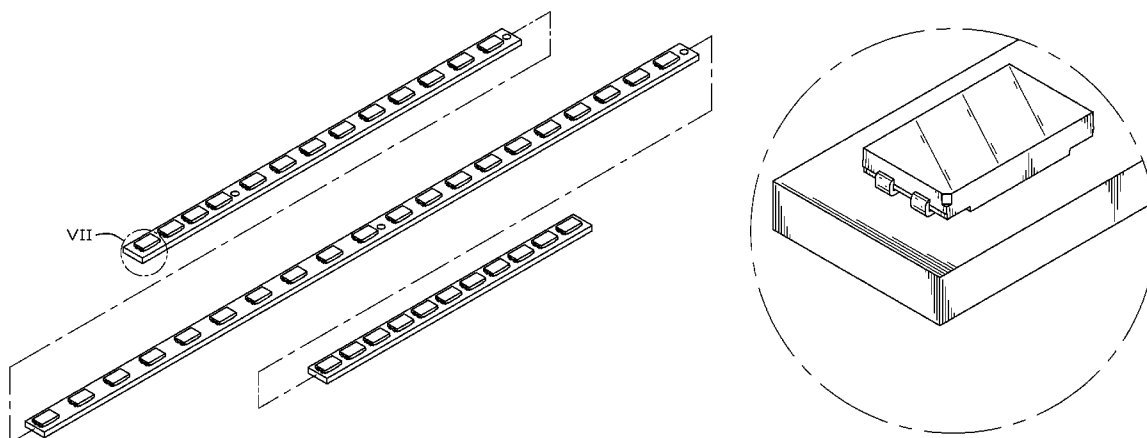

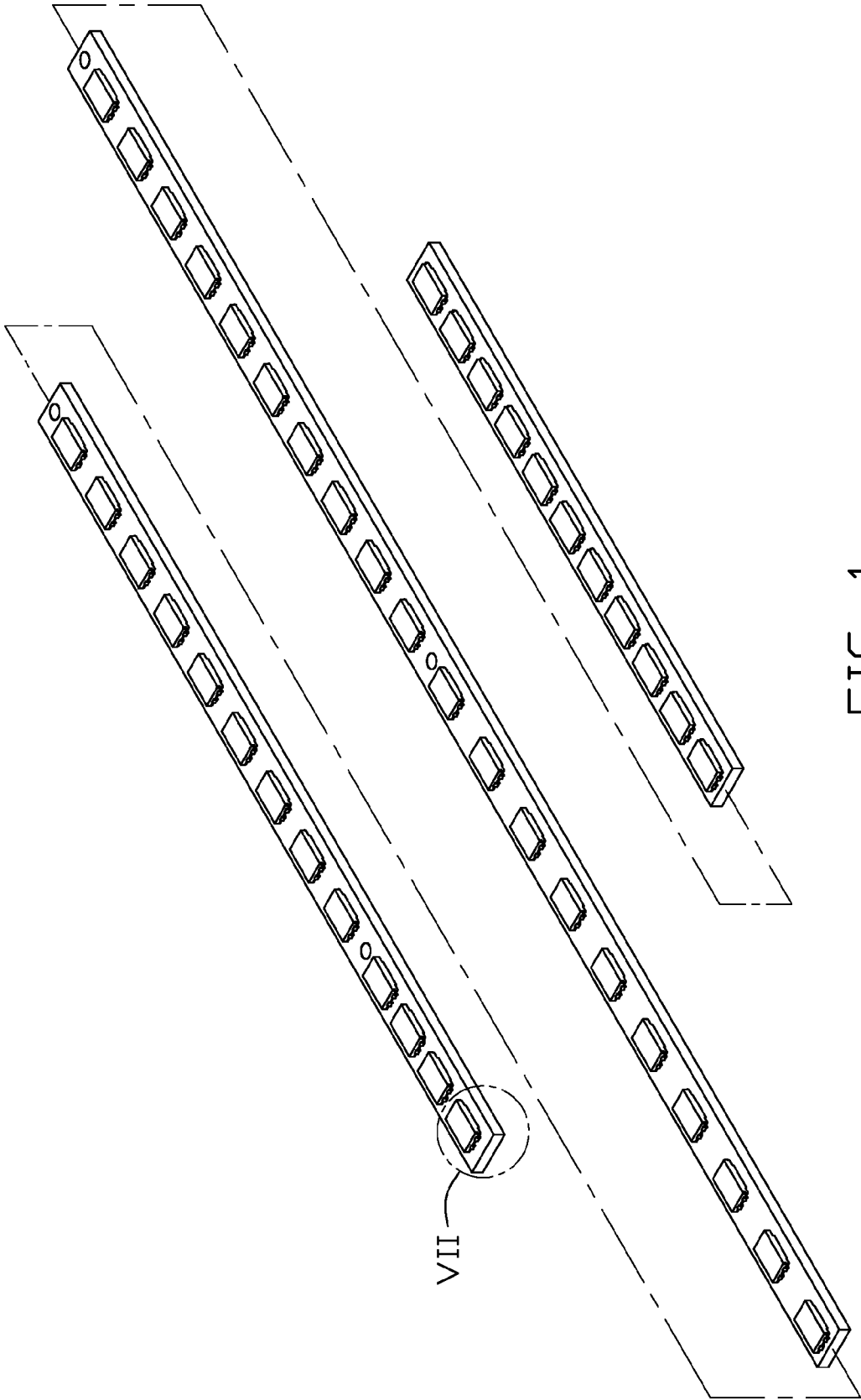

FIG. 1

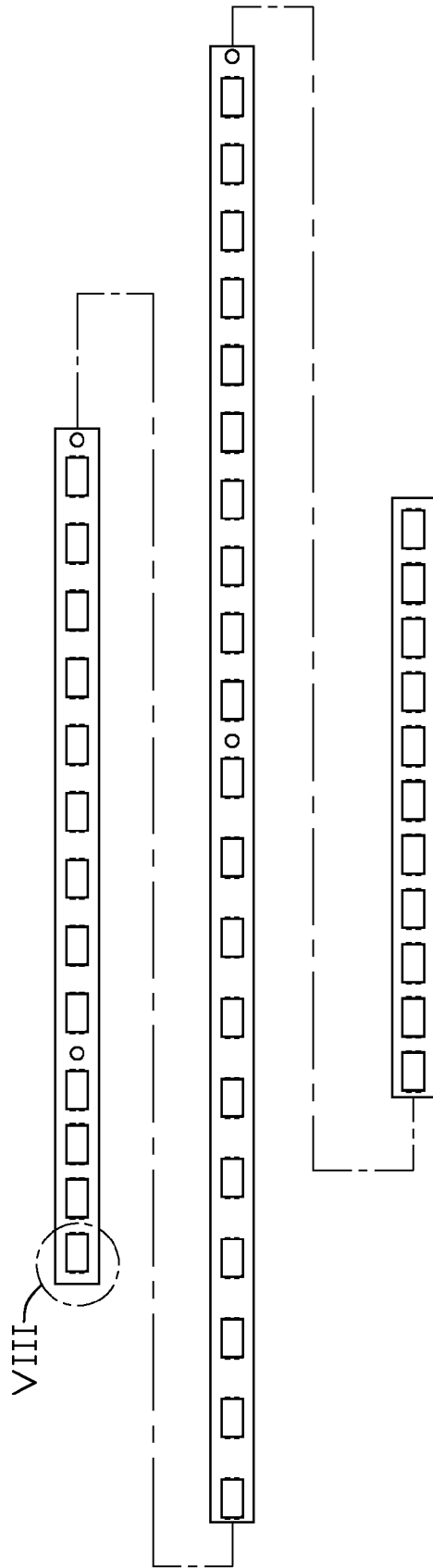

FIG. 2

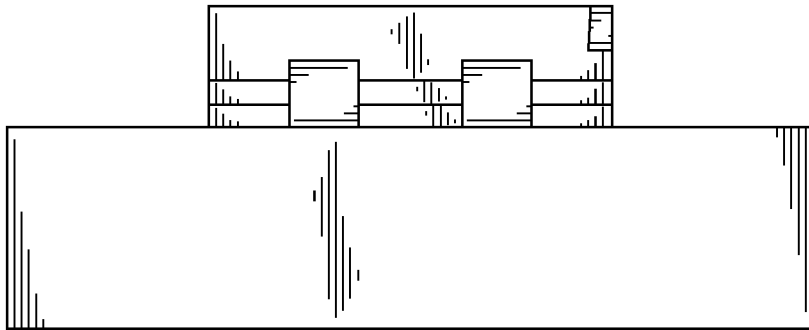

FIG. 4

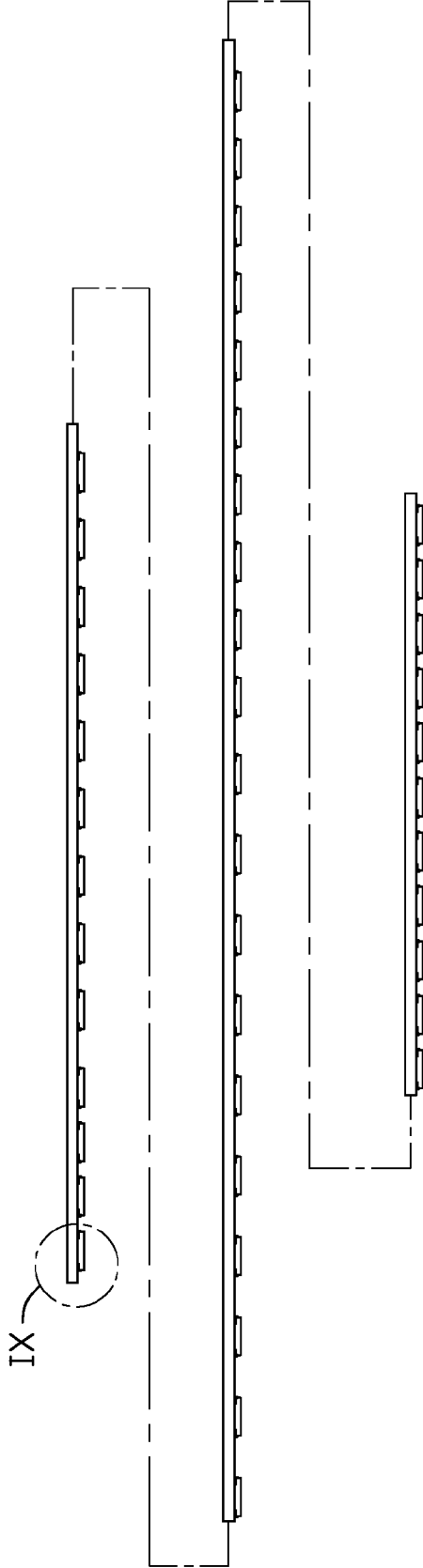

FIG. 5

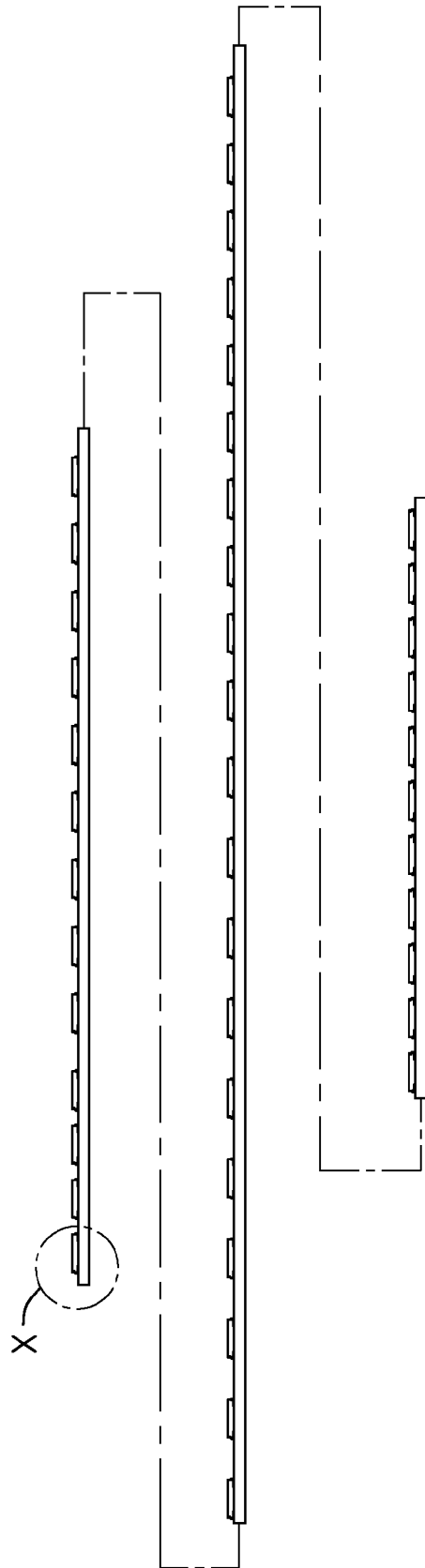

FIG. 6

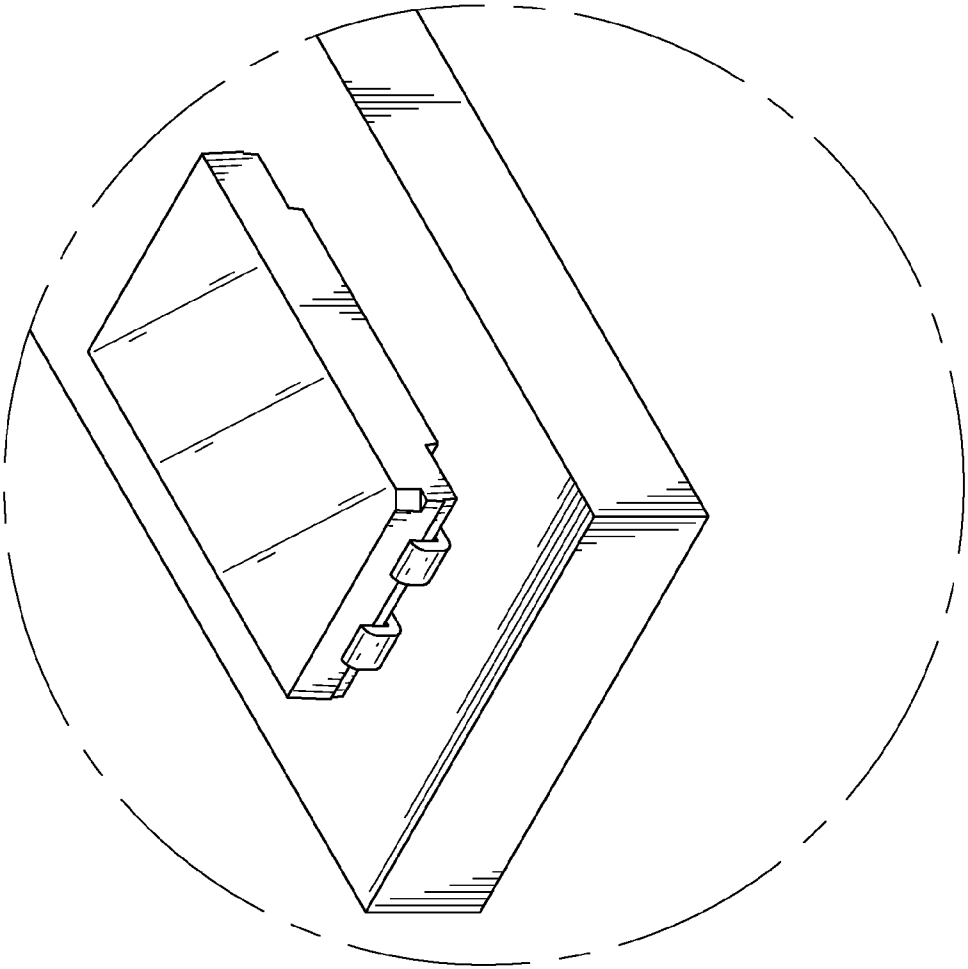

FIG. 7

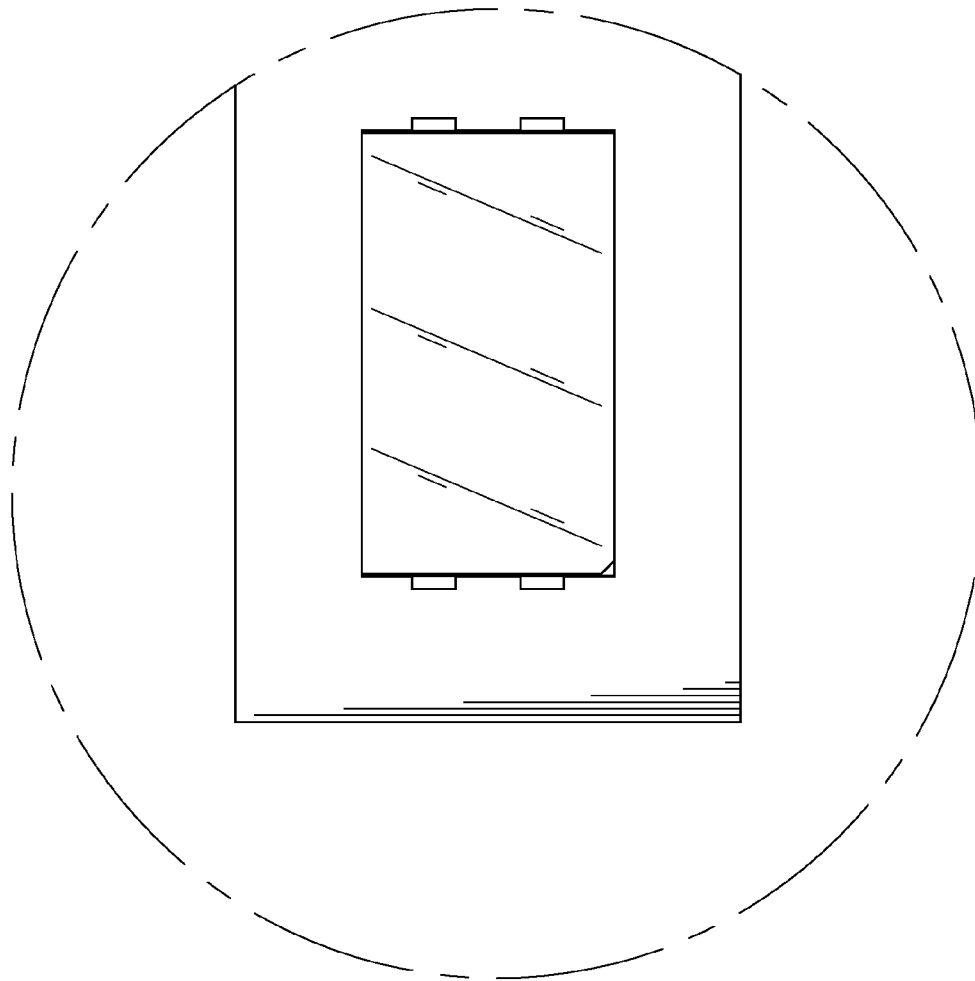

FIG. 8

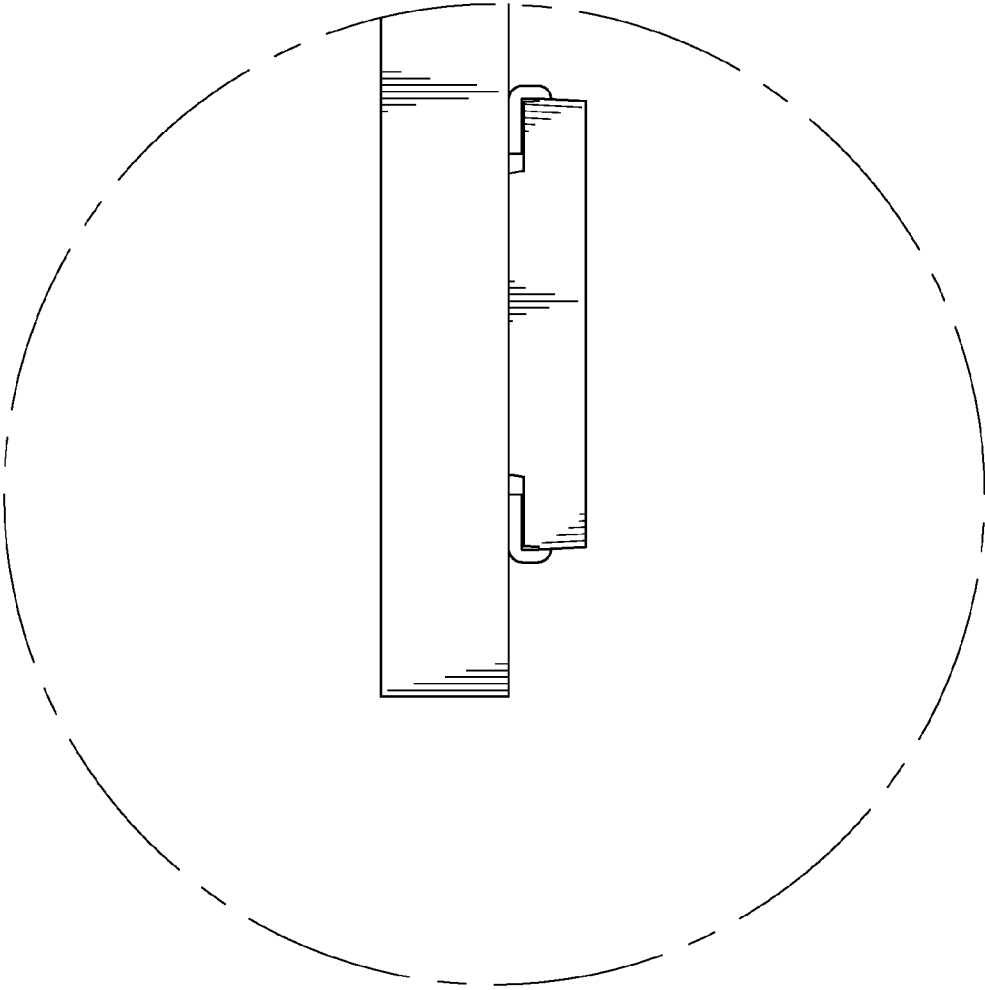

FIG. 9

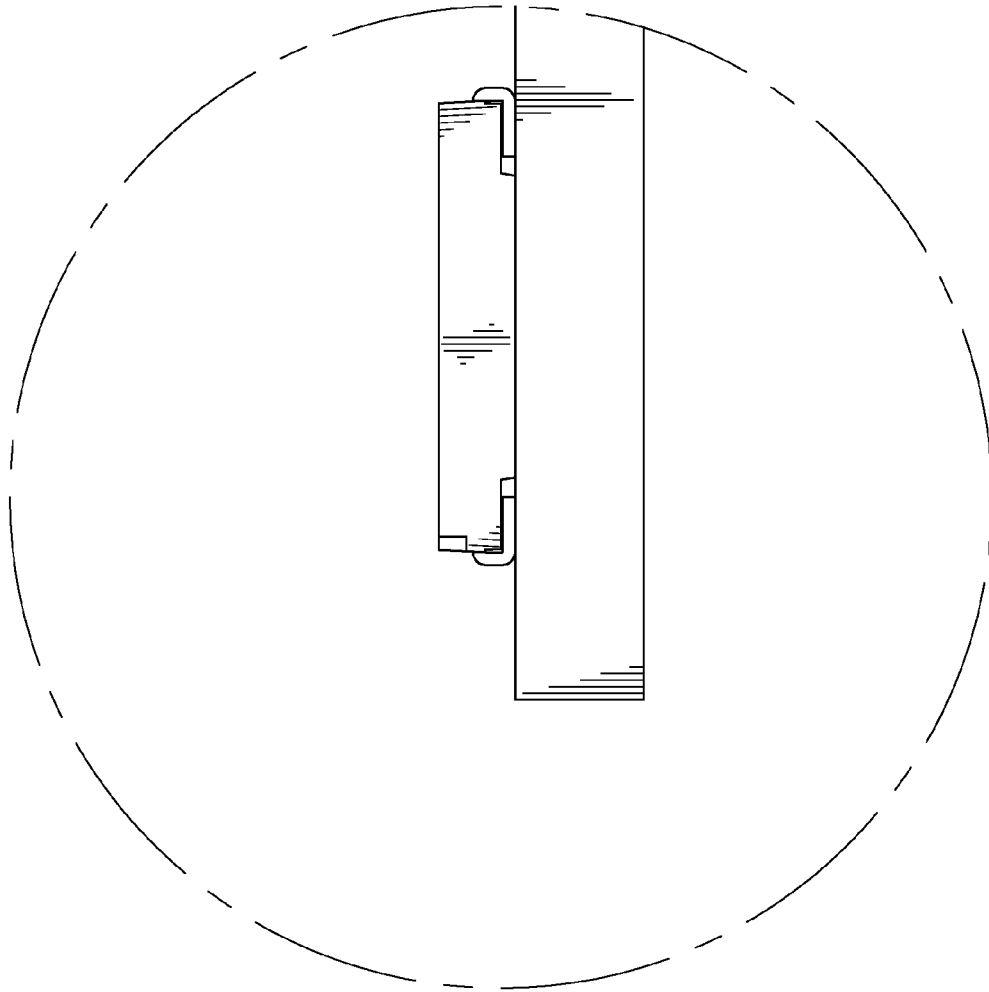

FIG. 10