

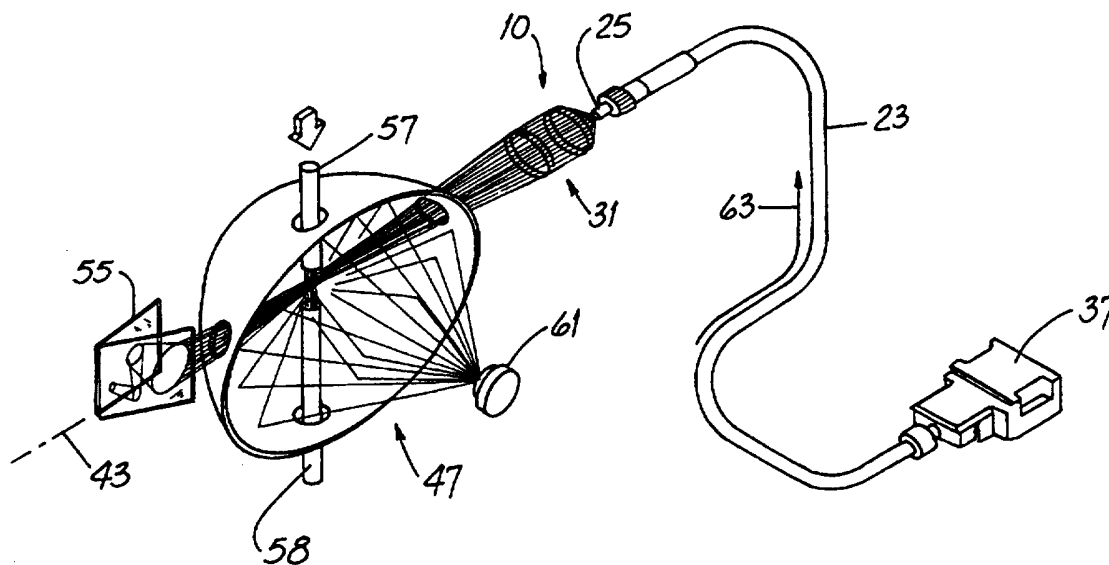

## INTERNATIONAL APPLICATION PUBLISHED UNDER THE PATENT COOPERATION TREATY (PCT)

<p>(51) International Patent Classification<sup>6</sup> : G01N 15/02, 21/00, G02B 6/26, 6/42, 6/00, 6/10</p>	A1	<p>(11) International Publication Number: <b>WO 97/19338</b></p> <p>(43) International Publication Date: 29 May 1997 (29.05.97)</p>
<p>(21) International Application Number: PCT/US96/17597</p> <p>(22) International Filing Date: 29 October 1996 (29.10.96)</p> <p>(30) Priority Data: 08/560,908 20 November 1995 (20.11.95) US</p> <p>(71) Applicant: VENTUREDYNE, LTD. [US/US]; 10201 W. Lincoln Avenue, Milwaukee, WI 53227 (US).</p> <p>(72) Inventors: CHANDLER, David, L.; 1505 Reedy Avenue, Highland, CA 92346 (US). FELBINGER, Raymond, J.; 23811 Avenida Columbia Mission, Viejo, CA 92691 (US). KREIKEBAUM, Gerhard; 3408 Broadmoor Boulevard, San Bernardino, CA 92404 (US).</p> <p>(74) Agent: SHUPE, Larry, L.; Jansson &amp; Shupe, Ltd., Suite M, 245 Main Street, Racine, WI 53403 (US).</p>		<p>(81) Designated States: JP, European patent (AT, BE, CH, DE, DK, ES, FI, FR, GB, GR, IE, IT, LU, MC, NL, PT, SE).</p> <p><b>Published</b> <i>With international search report.</i></p>

(54) Title: PARTICLE SENSOR WITH FIBER OPTIC CONDUCTOR



## (57) Abstract

The new particle sensor (10) is used for assaying particles (59) and includes a light source (11) comprising one or a plurality of light-emitting laser diodes (15). Light rays (29) from each diode (15) propagate along a flexible conduit (23) or "light pipe (27)", preferably a separate fiber optic strand (27a). The sensor (10) has a low voltage power source (19) and drives the diodes (15) at 1-5VDC. Light rays (29) from one or bundled fiber optic strand(s) (27a) is focused by a focusing lens (31) to provide an intense light beam (45) for small-particle detection. For improved design flexibility, the light source (11) may be mounted independently of the light beam long axis (43).

**FOR THE PURPOSES OF INFORMATION ONLY**

Codes used to identify States party to the PCT on the front pages of pamphlets publishing international applications under the PCT.

AM	Armenia	GB	United Kingdom	MW	Malawi
AT	Austria	GE	Georgia	MX	Mexico
AU	Australia	GN	Guinea	NE	Niger
BB	Barbados	GR	Greece	NL	Netherlands
BE	Belgium	HU	Hungary	NO	Norway
BF	Burkina Faso	IE	Ireland	NZ	New Zealand
BG	Bulgaria	IT	Italy	PL	Poland
BJ	Benin	JP	Japan	PT	Portugal
BR	Brazil	KE	Kenya	RO	Romania
BY	Belarus	KG	Kyrgystan	RU	Russian Federation
CA	Canada	KP	Democratic People's Republic of Korea	SD	Sudan
CF	Central African Republic	KR	Republic of Korea	SE	Sweden
CG	Congo	KZ	Kazakhstan	SG	Singapore
CH	Switzerland	LI	Liechtenstein	SI	Slovenia
CI	Côte d'Ivoire	LK	Sri Lanka	SK	Slovakia
CM	Cameroon	LR	Liberia	SN	Senegal
CN	China	LT	Lithuania	SZ	Swaziland
CS	Czechoslovakia	LU	Luxembourg	TD	Chad
CZ	Czech Republic	LV	Latvia	TG	Togo
DE	Germany	MC	Monaco	TJ	Tajikistan
DK	Denmark	MD	Republic of Moldova	TT	Trinidad and Tobago
EE	Estonia	MG	Madagascar	UA	Ukraine
ES	Spain	ML	Mali	UG	Uganda
FI	Finland	MN	Mongolia	US	United States of America
FR	France	MR	Mauritania	UZ	Uzbekistan
GA	Gabon			VN	Viet Nam

5

10

5 Title: PARTICLE SENSOR WITH FIBER OPTIC CONDUCTOR

Field of the Invention

This invention relates generally to air quality and, more particularly, to instruments for assaying airborne  
20 particulates.

Background of the Invention

Particle counters are used to detect light scattered by particles entrained in a stream of fluid, e.g., in an  
25 air stream. Such counters draw air (with particles entrained therein) from a room, for example, and flow such air along a tube and through an illuminated sensor "view volume" to obtain information about the number and size of such particles. Such information results from an  
30 analysis of the very small amounts of light reflectively "scattered" by the particle as it moves through the view volume.

Such counters direct the air and accompanying particles through the view volume at a particular flow  
35 rate (often measured in cubic feet per minute) from one tube (inlet tube) across an open space (view volume) to another tube (outlet tube). In counters of this type,

-2-

there is no tube wall (however transparent such wall might otherwise be) to impair light scattering and collecting. In other words, the particle is briefly illuminated by a very-small-diameter light beam as it  
5 "flies" through an open space.

Among other uses, particle counters are used to obtain a measure of air quality by providing information as to the number and size of particles present in some specified volume of air, e.g., a cubic meter. Even work  
10 environments which appear to human observation to be clean - business offices, manufacturing facilities and the like - are likely to have substantial numbers of microscopic airborne particles. While such particles are not usually troublesome to the human occupants, they can  
15 create substantial problems in certain types of manufacturing operations.

For example, semiconductors and integrated chips are made in what are known as "clean rooms," the air in which is very well filtered. In fact, clean rooms are usually  
20 very slightly pressurized using extremely clean air so that particle-bearing air from the surrounding environs does not seep in. And the trend in the semiconductor and integrated chip manufacturing industry is toward progressively smaller products.

The disadvantage of known particle counters and  
25 sensors becomes manifest when trying to detect very small particles, e.g., 0.1 micron and smaller, and/or when trying to detect particles present in a relatively high-flow-volume, e.g., one cubic foot per minute, air stream.  
30 Because the particle is very small and/or because it is moving relatively rapidly (thus passing quickly through the illuminated view volume), such particle reflects and scatters very little light.

An apparent solution involves increasing the  
35 intensity of the light beam to increase the quantum of light reflected and scattered by very small and/or fast-moving particles. Such efforts have proven largely

counterproductive since a more intense light source produces higher levels of random electronic or "shot" noise. And as the light beam becomes more intense, the quantum of light scattered by gas molecules tends to increase, irrespective of whether a particle is also present in the view volume. Shot noise and the increasing quanta of light scattered by gas molecules tends to partially or totally obscure the effect of the particle-scattered light.

10 To complicate matters even further, plasma-type light sources tend to vary in output power during operation, even if only slightly. As a consequence, the quantum of light scattered by gas molecules varies with variations in power. Plasma-type light sources are widely used in particle sensors and form a part of apparatus shown in, e.g., U.S. Patent Nos. 4,273,443 (Hogg); 4,728,190 (Knollenberg) and 4,798,465 (Knollenberg).

20 For high powered plasma sources used to detect very small particles at high flow rates, such variations can be of magnitudes much higher than the shot noise or the noise inherent in an electronic detector. These phenomena dramatically limit the attainable sensitivity. An approach to improving such sensitivity involves using "subtract circuits" which subtract an electrical signal representing only noise from a signal representing both noise and light scattered by a particle.

30 And plasma-type light sources are attended by other design considerations which, in view of the invention, are unnecessary. For example, such sources require high-voltage power supplies -- it is not unusual for a plasma source to require on the order of several thousand volts to "strike" and several hundred volts to continue operating.

35 Another design consideration is that a carefully-designed adjustment and mounting system is required to obtain and maintain the alignment of the plasma light

source. Such alignment is important to maximize the energy at the view volume.

Yet another design consideration attending use of plasma light sources is that the locus of the light beam axis is dictated by the position of the relatively-long tube body which forms a part of such a light source. The engineer is afforded very little design flexibility as to relative position of light source and light beam axis. And such tubes are relatively bulky and rather easily misaligned.

Still another fact of plasma-type light sources is that they employ mirrors and what are known as Brewster windows. Both are easily contaminated and may need frequent cleaning.

Plasma-type light sources are expected to have a life of 2 to 3 years in normal operation. While such life has been reasonably acceptable to equipment users, improvement in light source life would be welcomed.

An improved particle sensor which overcomes some of the problems and shortcomings of known particle sensors would be an important advance in the art.

#### Objects of the Invention

It is an object of the invention to provide an improved particle sensor overcoming some of the problems and shortcomings of the prior art.

Another object of this invention is to provide a particle sensor having an improved capability to detect very small airborne particles.

Yet another object of this invention is to provide an improved particle sensor which helps detect particles using (in certain embodiments) once-reflected light, thereby improving signal strength.

Another object of this invention is to provide an improved particle sensor which has an extended range for detecting smaller airborne particles.

Yet another object of this invention is to provide an improved particle sensor which requires no noise-subtracting circuitry.

Another object of this invention is to provide an improved particle sensor which exhibits substantially steady-state output power.

Another object of this invention is to provide an improved particle sensor which powers its light source at relatively low voltage.

Another object of this invention is to provide an improved particle sensor having increased life.

Still another object of this invention is to provide an improved particle sensor having a smaller size and lighter weight.

Another object of this invention is to provide an improved particle sensor having a less-sophisticated optic system that requires substantially no periodic cleaning.

Still another object of this invention is to provide a particle sensor having component parts that better retain alignment. How these and other objects are accomplished will become apparent from the following descriptions and from the drawings.

#### Summary of the Invention

As used herein, the term "particle counter" means an apparatus which, in addition to components such as a housing, mounting hardware, wiring and the like, includes a sensor and is used to count small airborne particles and determine particle size. The term "sensor" means the light source and the "hardware" (e.g., mirror(s), lens, light detector) used to collect light reflected by a particle and to "convert" such reflected light into electronic pulses.

The invention involves a particle counter for assaying an airborne particle and includes a light source for illuminating such particle. In one embodiment, the

source includes a plurality of light-emitting laser diodes, preferably mounted on a diode-supporting substrate which may be planar. Light emitted by each laser diode propagates along a separate fiber optic strand to illuminate the particle. More specifically, light propagating along the fiber optic strands is directed to a focusing lens, thereby focusing light at a view volume through which the particle passes as it moves through the sensor.

10 The new counter is free of a plasma light source and free of a high voltage power supply for such a light source. Most preferably, the new counter is free of a noise-subtracting circuit whereby one electrical signal representing background "noise" is subtracted from another electrical signal representing both background noise and light scattered by the particle.

The new counter also includes a sensor having a light-collecting apparatus with at least one mirror reflecting light scattered by the particle. Any one of several embodiments provides the desired result, i.e., detection of very small particles. In one embodiment, the mirror is an ellipsoidal mirror having a major focal point and the sensor includes a photodetector at the focal point for providing an electrical signal representing light scattered by the particle. (Persons of ordinary skill will recognize that a photodetector is a device that converts energy in one form, e.g., light, to energy in another form, e.g., electricity.) In another embodiment, the mirror is a spherical mirror reflecting light to an aspheric lens arrangement. Yet another embodiment has a plurality of mirrors including at least one Mangin mirror and a generally planar mirror reflecting light to the Mangin mirror.

35 And the invention may be considered in yet other ways. The new sensor has a plurality of devices, each device emitting light. A power supply provides electrical power to each of the devices at a voltage not

-7-

greater than 120 volts and, more preferably, at a voltage not greater than 15 to 20 volts DC. Most preferably, the power supply drives the devices at about 5VDC. (In other words, the new sensor neither needs nor has a high-  
5 voltage power supply for a light source as with known sensors using plasma devices as light sources.)

A plurality of light pipes form a bundle and each light pipe extends between a separate device and a bundle terminus. Light propagating along each of the light  
10 pipes is directed to a focusing lens adjacent to the terminus for focusing such light at the sensor view volume. The sensor also has apparatus for collecting light scattered by the particle and an apparatus of any one of the types described above is satisfactory.

15 In a highly preferred embodiment, each light pipe includes a fiber optic strand. In one variant thereof, the bundle is substantially parallel to the axis along which the particle-illuminating beam of light extends. In another variant, the bundle defines a curved path.  
20 The sensor is free of a plasma light source and free of electrical wires powering a light source at a voltage in excess of 120 volts.

Another aspect of the invention involves a light source for use in a particle sensor and in a counter  
25 using such sensor. Such source includes an electrically-powered device such as a single diode and a flexible light pipe such as a single fiber optic strand directing light from the device to a terminus. In a more specific aspect, the conduit has an input end and light from the  
30 device enters the input end and emanates from the terminus. The source is free of a Brewster window (as used with plasma-type sources) and operates at a voltage well less than 120 volts.

35 Further details of the invention are set forth in the following detailed description and in the drawings.

### Brief Description of the Drawings

FIGURE 1 is a top plan view, greatly enlarged, of one embodiment of a light source including an array of laser diodes.

5        FIGURE 2 is a top plan view, greatly enlarged, of another embodiment of a light source including a single laser diode.

10        FIGURE 3 is a simplified perspective view of one embodiment of the new particle sensor. Parts, e.g., the sensor housing, are omitted and paths of light rays have been separated for clarity.

FIGURE 4 is a simplified perspective view of another embodiment of the new particle sensor. Parts are omitted and paths of light rays have been separated for clarity.

15        FIGURE 5 is a simplified top plan view of yet another embodiment of the new particle sensor. Parts are omitted, other parts are broken away and paths of light rays have been separated for clarity.

20        FIGURE 6 is a simplified top plan view of still another embodiment of the new particle sensor. Parts are omitted, other parts are broken away and paths of light rays have been separated for clarity.

25        FIGURE 7 is a representative view of an instrument cabinet housing a particle sensor and a separately-mounted light source.

### Detailed Descriptions of Preferred Embodiments

Before describing the new sensor 10, it will be helpful to have an understanding of aspects of the new light source 11 used in such sensor 10. Referring first to FIGURE 1, the source 11 has an electrically-powered device 13 emitting light. In a preferred embodiment, the device 13 includes an array 14 of laser diodes 15 mounted "in line" on a generally planar supporting substrate 17. (While an in-line array 14 is shown, other arrangements, e.g., a matrix, are possible.) The diodes 15 are

30  
35

connected in parallel to a low-voltage source of electrical power 19, e.g., a 1-5 volts DC power supply.

In the embodiment of FIGURE 2, the device 13 is a single laser diode 15 supported on a substrate 17.

5 Electrical leads 21 connect such diode 15 to a source of electrical power 19. (While single laser diodes 15 having the required power, e.g., on the order of 20-30 watts, are not known to be now available, their development seems to be likely. The invention  
10 contemplates such a development.)

The source 11 also has a flexible conduit 23 directing the light from the device 13 to a terminus 25. In the preferred embodiment, the conduit 23 includes a separate light pipe 27 such as a fiber optic strand 27a  
15 which directs light from each diode 15 to the terminus 25. Preferably, the light source 11 also includes a lens 31 at the terminus 25 for focusing light rays 29 from each light pipe to a common focal point 33 at the "view volume" 35 of a particle sensor 10. (Persons of ordinary  
20 skill in the art will recognize that as used in connection with a particle sensor 10, the view volume is that spatial region at the intersection of a light beam and the path of a particle travelling through the sensor 10.)

25 Referring also to FIGURE 3, one preferred embodiment of the new sensor 10 will now be described. The array-type source 11 of FIGURE 1 or the single-diode source 11 of FIGURE 2 is within an enclosure 37 configured to be readily mounted within the housing 39 of a particle  
30 counter 41. (A housing 39 and counter 41 are shown in FIGURE 7 which includes a light source 11 slightly different than that of FIGURE 3.) A short conduit 23 of bundled fiber optic strands 27a extends from the enclosure 37 to a terminus 25 where light from each  
35 strand 27a emanates to a focusing optic system such as a lens 31. (As used herein, the term "lens" means one or more optical devices for focusing light.) In this

-10-

embodiment, the conduit 23 and strands 27a are substantially parallel to the beam axis 43.

The lens 31 focuses the light rays 29 to form a light beam 45 which has extremely small diameter and is very intense. The beam 45 is directed to a light collecting apparatus 47 having at least one mirror 49. The apparatus 47 of FIGURE 3 includes an ellipsoidal mirror 49 and the beam 45 is directed through an entry opening 51 in the mirror 49, through the sensor view volume 35 (located at the minor focal point of such mirror 49) and out of an exit opening 53 in the mirror 49. Light which is not reflected from a particle to the mirror 49 (as described below) is "killed" by a light trap 55.

Air from a room, the air cleanliness of which is being monitored, is drawn in through the tube 57, flows through the view volume 35 and exits the tube 58 at some flow rate up to about one cubic foot per minute or more. Particles 59 entrained in the air stream fly through the view volume 35 and intersect the light beam 45. Each particle 59 reflects light rays to the mirror 49 and thence to a photodetector 61 at the major focal point of the mirror 49. The resulting electrical output signal from the sensor 10 is analyzed to develop information relating to particle size and number.

In the embodiment of FIGURE 4, a longer conduit 23 and one or more fiber optic strands 27a forming such conduit 23 define a curved path as represented by the arrow 63. Of course, the strands 27a are not parallel to the beam axis 43 over the entirety of their length as is the case in the embodiment of FIGURE 3.

FIGURES 5 and 6 depict other arrangements for a light collecting sensor 10 with which the new light source 11 may be used. In the arrangement of FIGURE 5, light rays 29 reflected downwardly (as viewed in FIGURE 5) by a particle 59 in the view volume 35 is focused by an aspheric focusing lens 65. Such focused light is

-11-

sensed by a light detector 61, the electrical output signal of which is analyzed as described above. Light rays 29 reflected upwardly by a particle in the view volume 35 strikes a spherical mirror 67 which re-directs such light rays 29 to the aspheric focusing lens 65.

The light collecting apparatus 47 of FIGURE 6 includes a set of Mangin mirrors 69 collecting light rays 29 reflected upwardly (as shown in the drawing) by a particle 59 in the view volume 35. Such light rays 29 are reflectively directed to a light detector 61. Light rays 29 reflected downwardly by the particle 59 is reflected by a planar mirror 71 coacting with a second set of Mangin mirrors 69a which reflectively re-direct such light rays 29 to the first set of Mangin mirrors 69 and thence to the detector 61.

The matter of design flexibility is also exemplified by FIGURE 7. In the representation, an instrument cabinet 73 in the counter 41 houses a particle sensor 10 sans light source 11. A separately-mounted light source 11 has its enclosure 37 mounted away from the cabinet 73. Heat radiating from the enclosure 37 is thereby isolated from the sensor 10. Light from the enclosure 37 is directed along the light conduit 23 to the sensor 10.

As used in this specification, an "array" means a grouping of two or more "light emitters," e.g., diodes 15, each electrically-powered and emitting light.

While the principles of the invention have been shown and described in connection with but a few embodiments, it is to be understood clearly that such embodiments are exemplary and not limiting.

## CLAIMS

What is claimed:

- 5           1. In a particle sensor for assaying a particle and including a light source for illuminating the particle, characterized in that:
- the source includes a plurality of light-emitting laser diodes; and
- 10           -light emitted by each laser diode propagates along a separate fiber optic strand, whereby the particle is illuminated.
2. The sensor of claim 1 wherein:
- 15           -the source provides a beam of light along an axis; and
- the fiber optic strands are substantially parallel to the axis.
- 20           3. The sensor of claim 1 wherein:
- the fiber optic strands define a curved path.
4. The sensor of claim 1 wherein:
- the fiber optic strands define a straight path.
- 25           5. The sensor of claim 1 wherein:
- light propagating along the fiber optic strands is directed to at least one lens, thereby focusing light at a view volume.
- 30           6. The sensor of claim 1 wherein the laser diodes are powered by a low voltage power supply at a voltage less than 10 volts.
- 35           7. The sensor of claim 1 further including a light-collecting apparatus having at least one mirror reflecting light scattered by the particle.

-13-

8. The sensor of claim 7 wherein the mirror is an ellipsoidal mirror having a major focal point and the  
5 sensor includes a photodetector at the focal point for providing an electrical signal representing light scattered by the particle.

9. The sensor of claim 7 wherein the mirror is a  
10 spherical mirror reflecting light to at least one aspheric lens..

10. The sensor of claim 7 including a plurality of mirrors, such plurality including:  
15 -at least one Mangin mirror; and  
-a generally planar mirror reflecting light to the Mangin mirror.

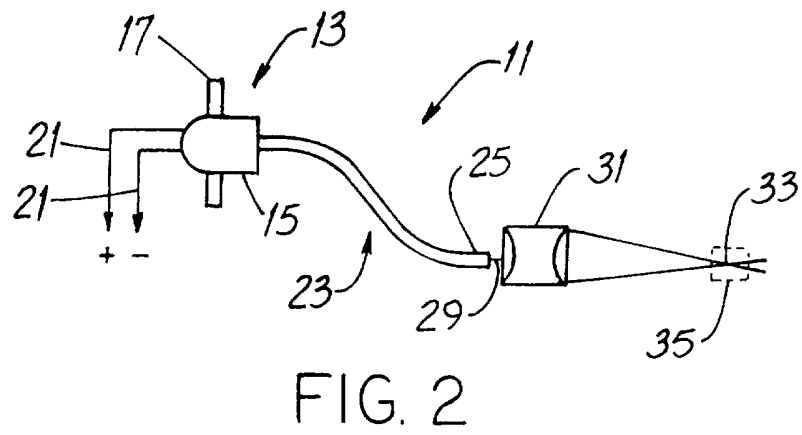
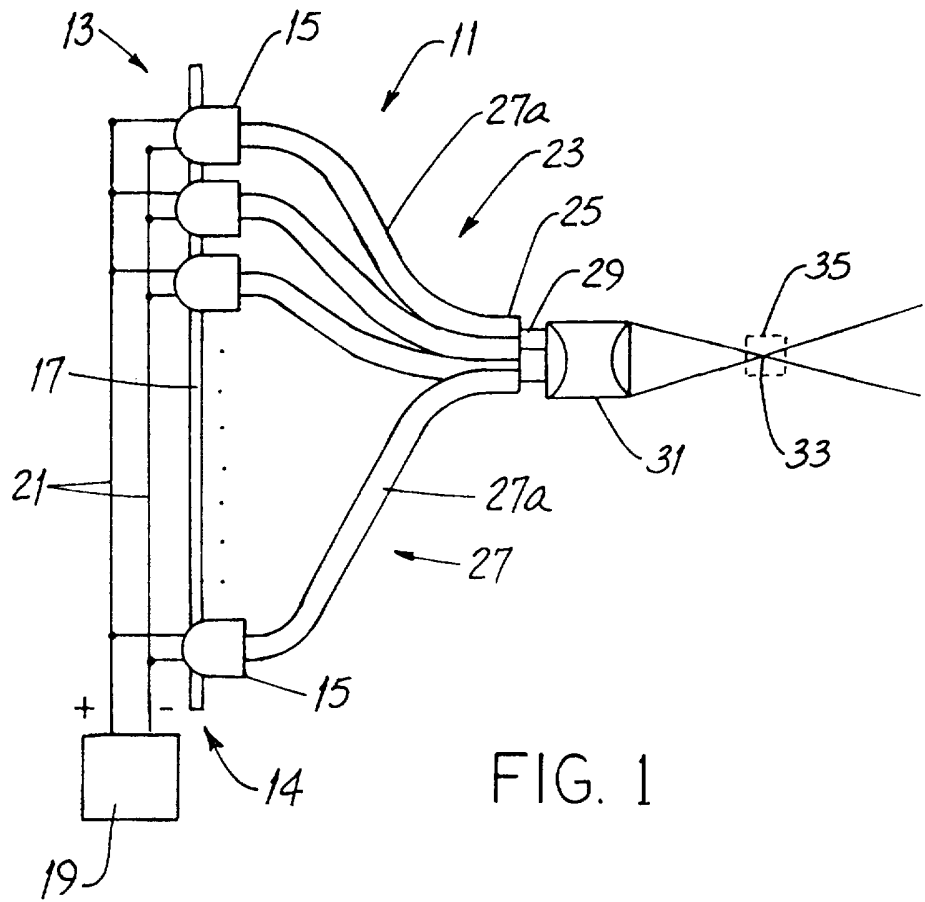

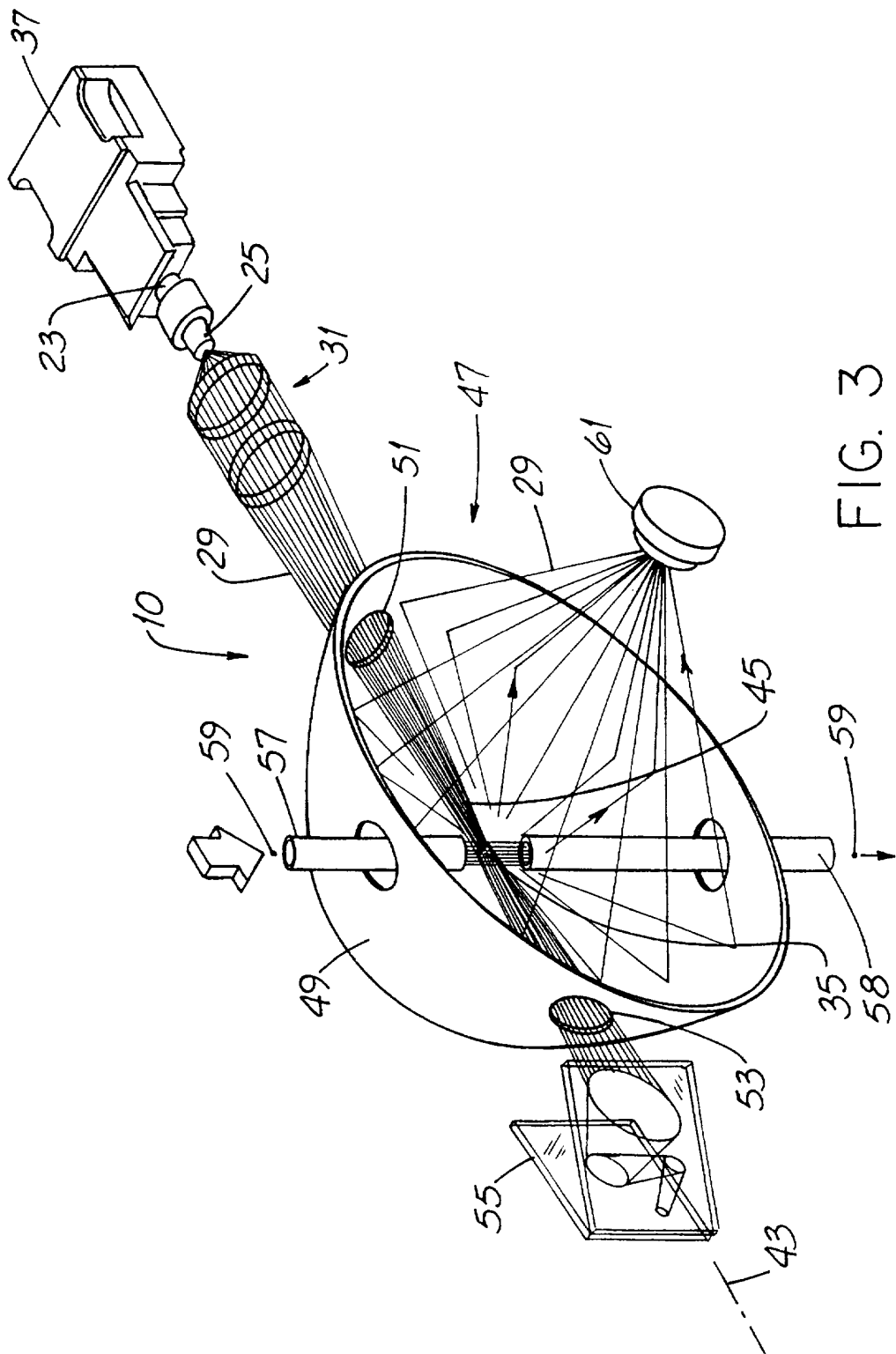

FIG. 3

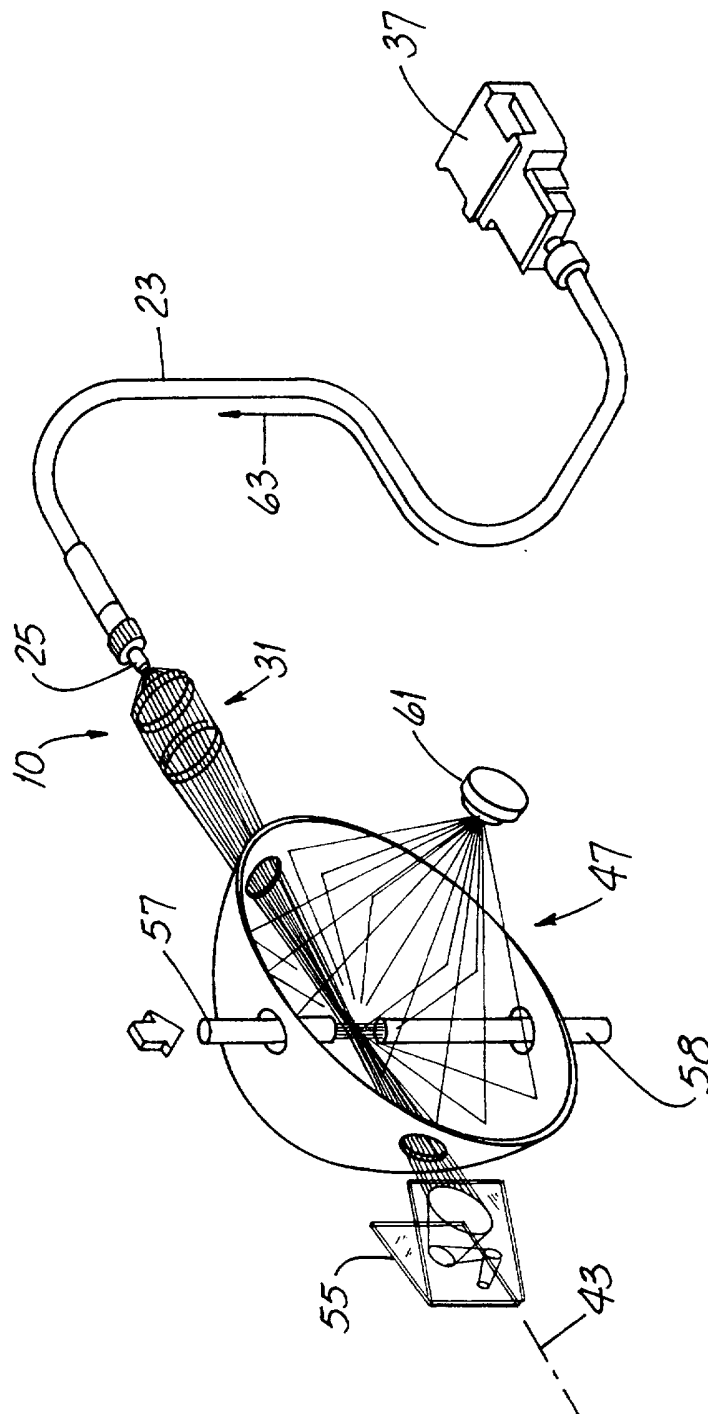

FIG. 4

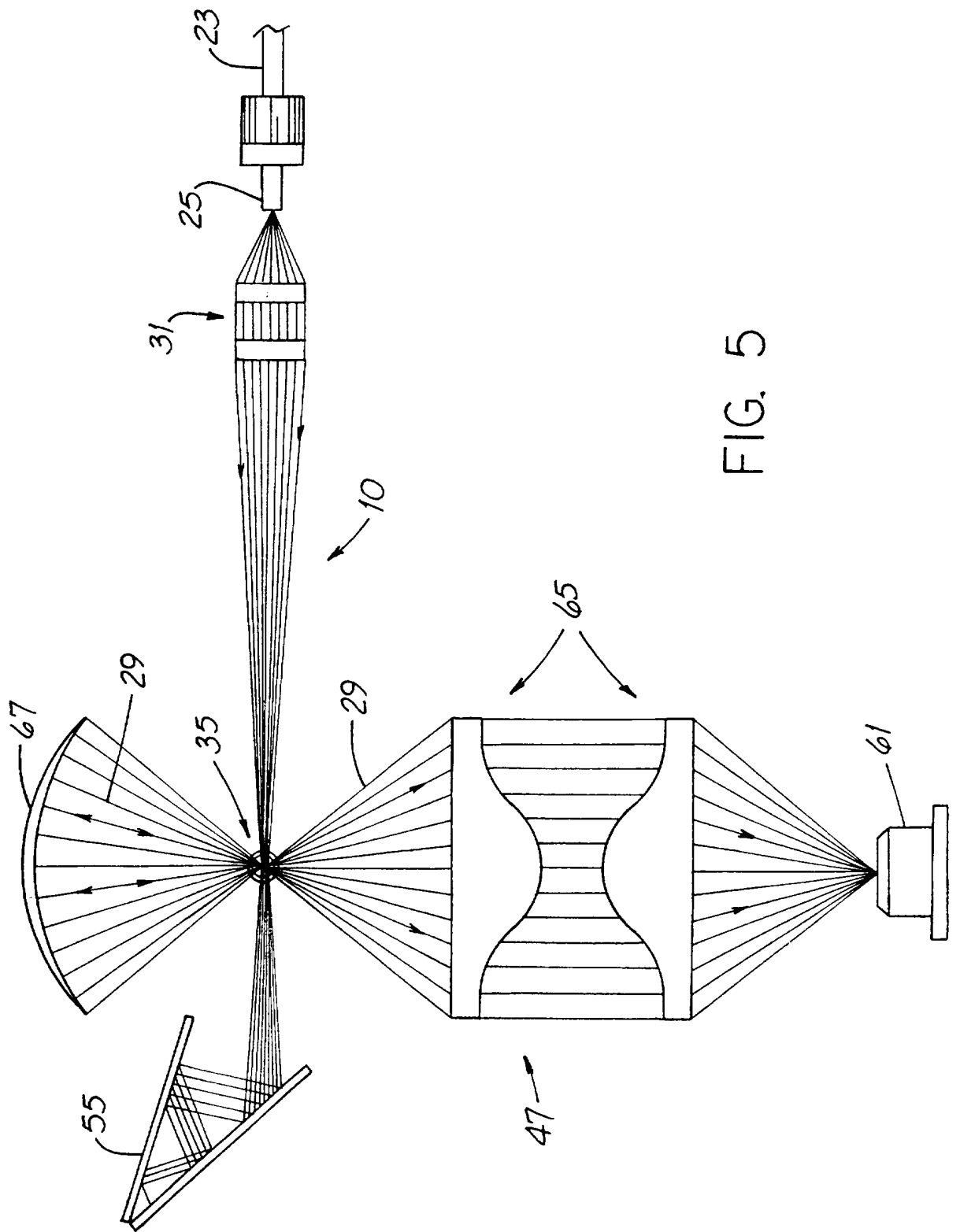

FIG. 5

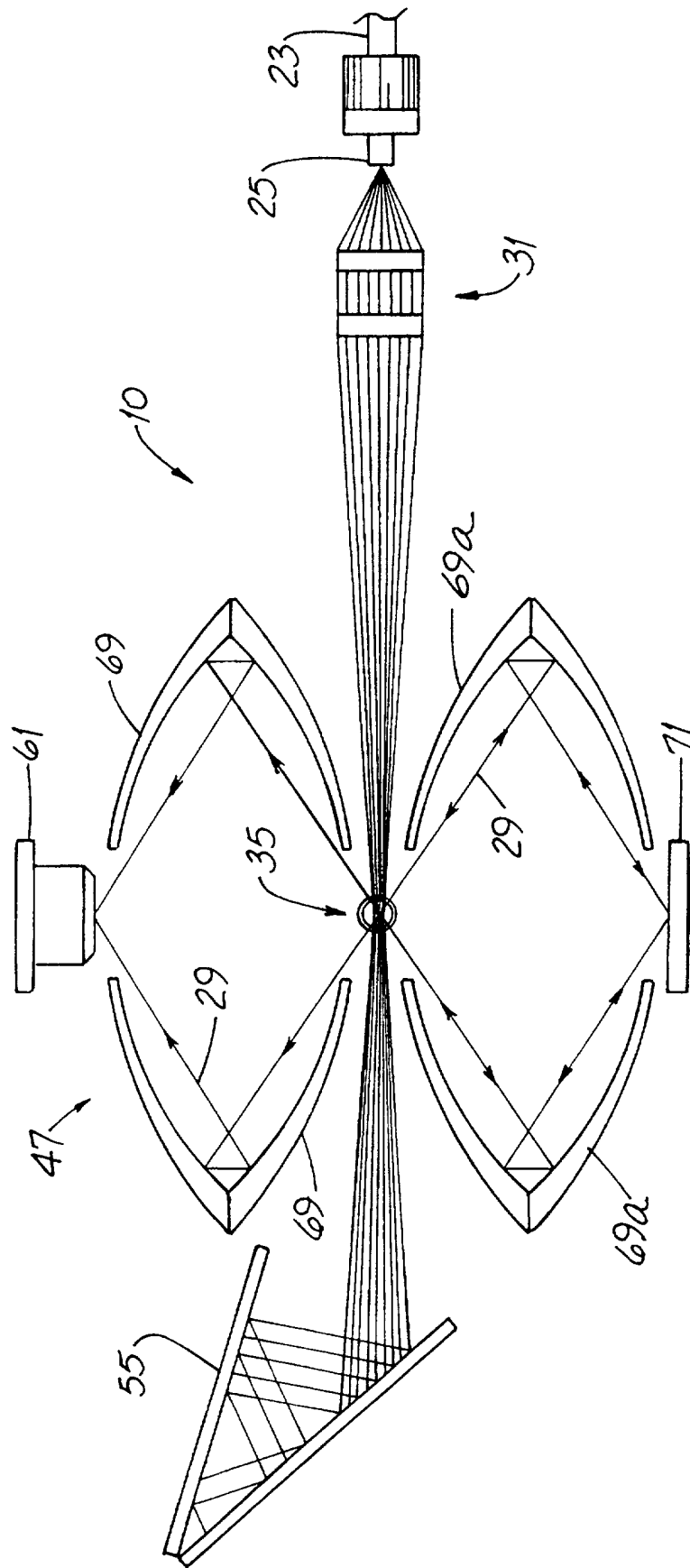

FIG. 6

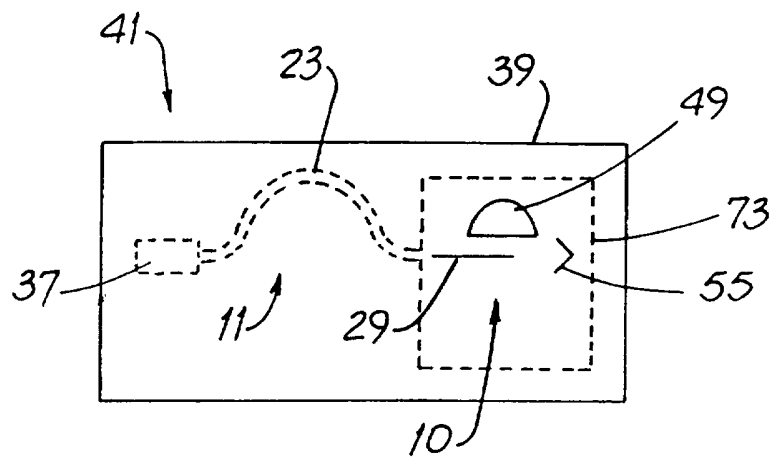

FIG. 7

INTERNATIONAL SEARCH REPORT

International application No.  
PCT/US96/17597

**A. CLASSIFICATION OF SUBJECT MATTER**

IPC(6) :G01N 15/02, 21/00; G02B 6/26, 6/42, 6/00, 6/10  
US CL :356/335-343; 385/31, 146-147, 901

According to International Patent Classification (IPC) or to both national classification and IPC

**B. FIELDS SEARCHED**

Minimum documentation searched (classification system followed by classification symbols)

U.S. : 356/335-343; 385/31, 146-147, 901

Documentation searched other than minimum documentation to the extent that such documents are included in the fields searched

Electronic data base consulted during the international search (name of data base and, where practicable, search terms used)

**C. DOCUMENTS CONSIDERED TO BE RELEVANT**

Category*	Citation of document, with indication, where appropriate, of the relevant passages	Relevant to claim No.
Y	US 5,467,189 A (KREIKEBAUM ET AL) 14 NOVEMBER 1995, See Fig 1 and col 8, line 55 - col 10, line 66.	1-10
Y	US 5,394,489 A (KOCH) 28 FEBRUARY 1995, See whole document.	1-10
Y	US 4,871,251 A (PREIKSCHAT ET AL), 03 OCTOBER 1989, See Fig 16-18 and related text.	1-10
Y	US 5,181,082 A JEANNOTTE ET AL), 19 JANUARY 1993, See Figs 17-18 and related text.	1-10

Further documents are listed in the continuation of Box C.  See patent family annex.

* Special categories of cited documents:	"T" later document published after the international filing date or priority date and not in conflict with the application but cited to understand the principle or theory underlying the invention
"A" document defining the general state of the art which is not considered to be of particular relevance	"X" document of particular relevance; the claimed invention cannot be considered novel or cannot be considered to involve an inventive step when the document is taken alone
"E" earlier document published on or after the international filing date	"Y" document of particular relevance; the claimed invention cannot be considered to involve an inventive step when the document is combined with one or more other such documents, such combination being obvious to a person skilled in the art
"L" document which may throw doubts on priority claim(s) or which is cited to establish the publication date of another citation or other special reason (as specified)	"&" document member of the same patent family
"O" document referring to an oral disclosure, use, exhibition or other means	
"P" document published prior to the international filing date but later than the priority date claimed	

Date of the actual completion of the international search 03 DECEMBER 1996	Date of mailing of the international search report <b>12 DEC 1996</b>
Name and mailing address of the ISA/US Commissioner of Patents and Trademarks Box PCT Washington, D.C. 20231 Facsimile No. (703) 305-3230	Authorized officer <i>JASON D. VIERRA EISENBERG</i> Telephone No. 703-305-0596