



- (51) International Patent Classification:  
Not classified
- (21) International Application Number:  
PCT/US2017/059890
- (22) International Filing Date:  
03 November 2017 (03.11.2017)
- (25) Filing Language:  
English
- (26) Publication Language:  
English
- (30) Priority Data:  
62/416,902 03 November 2016 (03.11.2016) US
- (71) Applicant: CONVIDA WIRELESS, LLC [US/US]; 200  
Bellevue Parkway, Suite 300, Wilmington, DE 19809-3727  
(US).
- (72) Inventors: IYER, Lakshmi, R.; 200 Bellevue Parkway,  
Suite 300, Wilmington, DE 19809-3727 (US). TSAI, Al-  
lan, Y.; 200 Bellevue Parkway, Suite 300, Wilmington,  
DE 19809-3727 (US). XU, Tianyi; 11717 Stoney Peak  
Drive, Apt. 17, San Diego, CA 92128 (US). ZHANG,

Guodong; 200 Bellevue Parkway, Suite 300, Wilming-  
ton, DE 19809-3727 (US). ADJAKPLE, Pascal, M.; 200  
Bellevue Parkway, Suite 300, Wilmington, DE 19809-3727  
(US). ELSAMADOUNY, Ahmed; 1300 Fayette Street,  
Apt. 210, Conshohocken, PA 19428 (US). KHAN, Salman;  
11A Platt Avenue, West Babylon, NY 11704 (US). LI, Yi-  
fan; 200 Bellevue Parkway, Suite 300, Wilmington, DE  
19809-3727 (US).

(74) Agent: PATEL, Tayan, B. et al.; Baker & Hostetler LLP,  
2929 Arch Street, Cira Centre, 12th Floor, Philadelphia, PA  
19104-2891 (US).

(81) Designated States (unless otherwise indicated, for every  
kind of national protection available): AE, AG, AL, AM,  
AO, AT, AU, AZ, BA, BB, BG, BH, BN, BR, BW, BY, BZ,  
CA, CH, CL, CN, CO, CR, CU, CZ, DE, DJ, DK, DM, DO,  
DZ, EC, EE, EG, ES, FI, GB, GD, GE, GH, GM, GT, HN,  
HR, HU, ID, IL, IN, IR, IS, JO, JP, KE, KG, KH, KN, KP,  
KR, KW, KZ, LA, LC, LK, LR, LS, LU, LY, MA, MD, ME,  
MG, MK, MN, MW, MX, MY, MZ, NA, NG, NI, NO, NZ,  
OM, PA, PE, PG, PH, PL, PT, QA, RO, RS, RU, RW, SA,

(54) Title: REFERENCE SIGNALS AND CONTROL CHANNELS IN NR

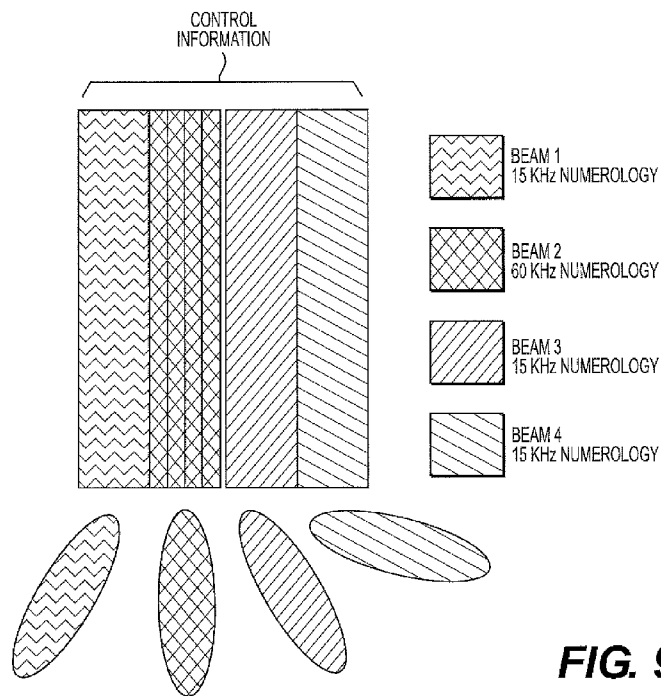


FIG. 9

(57) Abstract: The present application at least describes a frame structure in new radio. The frame structure includes a self-contained transmission time interval. The transmission time interval includes a control information region including plural beams. The interval also includes a downlink transmission channel region including plural beams. The frame structure is configured for downlink control information to be swept through the time interval. The frame structure is also configured for an uplink or downlink grant resource subsequently to be swept through the time interval. The present application is also directed to a method for configuring user equipment.



SC, SD, SE, SG, SK, SL, SM, ST, SV, SY, TH, TJ, TM, TN,  
TR, TT, TZ, UA, UG, US, UZ, VC, VN, ZA, ZM, ZW.

- (84) Designated States** (*unless otherwise indicated, for every kind of regional protection available*): ARIPO (BW, GH, GM, KE, LR, LS, MW, MZ, NA, RW, SD, SL, ST, SZ, TZ, UG, ZM, ZW), Eurasian (AM, AZ, BY, KG, KZ, RU, TJ, TM), European (AL, AT, BE, BG, CH, CY, CZ, DE, DK, EE, ES, FI, FR, GB, GR, HR, HU, IE, IS, IT, LT, LU, LV, MC, MK, MT, NL, NO, PL, PT, RO, RS, SE, SI, SK, SM, TR), OAPI (BF, BJ, CF, CG, CI, CM, GA, GN, GQ, GW, KM, ML, MR, NE, SN, TD, TG).

**Published:**

- *without international search report and to be republished upon receipt of that report (Rule 48.2(g))*

## REFERENCE SIGNALS AND CONTROL CHANNELS IN NR

### CROSS-REFERENCE TO RELATED APPLICATIONS

[0001] This application claims the benefit of priority to U.S. Provisional Application no. 62/416,902 filed November 4, 2016, entitled, "Reference Signals and Control Channels in NR" the contents of which is incorporated by reference in its entirety.

### BACKGROUND

[0002] Control channels for Uplink (UL) and Downlink (DL) New Radio (NR) have a beam centric architecture. While the NR Downlink Control Information (DCI) is precoded, the DL control signaling on multiple beams is currently undefined. Protocols to support channel estimation for DL control signals are needed in NR.

[0003] In high carrier frequencies, phase noise becomes a significant problem. Tracking RS (TRS) aids in estimating and compensating for phase noise. Resource allocations for Demodulation Reference Signals (DMRS) and TRS have not been finalized in NR.

[0004] SRS design for UL, especially in a beam centric architecture, has not been addressed in NR. Techniques for assigning SRS resources on multiple beams and in multiple numerologies is needed.

[0005] Currently in LTE, Channel State Information Interference Channel Measurement (CSI-ICM) is used to measure the interference power configured in RRC signaling. Interference may be caused by MIMO transmissions or beams from similar or different Transmission and Reception Points (TRP)s. As the number of interference sources increase, the number of interference hypotheses exponentially increase in turn. Because one CSI-ICM resource is required for each interference hypothesis, a large overhead for DL transmission is realized. This potentially limits a NR node's flexibility for scheduling MU-MIMO.

### SUMMARY

[0006] This summary is provided to introduce a selection of concepts in a simplified form that are further described below in the detailed description. This summary is not intended to identify key features or essential features of the claimed subject matter, nor is it intended to be used to limit the scope of the claimed subject matter. Furthermore, the claimed subject matter is not limited to limitations that solve any or all disadvantages noted in any part of this disclosure.

[0007] In one aspect of the application, a frame structure in new radio is described. The frame structure includes a self-contained transmission time interval. The transmission interval includes a control information region including plural beams, and a downlink transmission channel region

including plural beams. The downlink control information is swept through the time interval. Subsequently, an uplink or downlink grant resource is swept through the time interval.

**[0008]** In another aspect of the application, a frame structure operating in new radio is described. The frame structure includes a transmission bandwidth, which includes a timeslot for control and data signaling. The timeslot has a first numerology and a second numerology. The first numerology supports a first subcarrier spacing. The second numerology supports a second subcarrier spacing. Further, a fixed time slot includes a beam having a sounding reference signal.

**[0009]** In yet another aspect, a method for configuring user equipment. The method includes a step of configuring a set of 'K' channel state information interference channel measurement (CSI-ICM) and channel state interference reference signal (CSI-RS) resources for a group of user equipment. The method also includes a step of indicating, for one of the user equipment in the group, at least 'N' of the 'K' CSI-ICM resources via dynamic signaling based on interference. The method also includes a step of transmitting downlink control information including the CSI-ICM to the group; a CSI-RS (and CSI-interference channel measurement) protocol to the user equipment. The method further includes a step of receiving, from the UE in the group, feedback of the CSI and CSI-ICM for the interference channel. The method even further includes a step of scheduling a MU-MIMO transmission for the user equipment. The method yet even further includes a step of determining a cancelation of interference transmitted from one user equipment to other co-scheduled UEs. There has thus been outlined, rather broadly, certain embodiments of the invention in order that the detailed description thereof may be better understood, and in order that the present contribution to the art may be better appreciated.

#### **BRIEF DESCRIPTION OF THE DRAWINGS**

**[0010]** In order to facilitate a more robust understanding of the application, reference is now made to the accompanying drawings, in which like elements are referenced with like numerals. These drawings should not be construed to limit the application and are intended only to be illustrative.

**[0011]** Figure 1 is a diagram that illustrates a Flexible Frame Structure Concept in NR.

**[0012]** Figure 2 is a diagram that illustrates control information transmitted on beams followed by shared channel transmission.

**[0013]** Figure 3 is a diagram that illustrates some NR-DCI may be repeated on the beams. Figure 3A is a diagram that illustrates NR-DCI for a UE is repeated in all beams. Figure 3B is a diagram that illustrates NR-DCI for a UE is transmitted only on 2 out of 4 beams.

**[0014]** Figure 4 is a diagram that illustrates each beam the control region is followed by shared channel transmission

- [0015] Figure 5 is a diagram that illustrates a control RS or beam RS may be used to estimate the channel
- [0016] Figure 6 is a diagram that illustrates a control DMRS is used in UE-specific manner to decode the NR-DCI.
- [0017] Figure 7 is a diagram that illustrates a control DMRS shared between control and data region if they are precoded in the same way.
- [0018] Figure 8 is a diagram that illustrates a beam sweeping through control symbols of same numerology.
- [0019] Figure 9 is a diagram that illustrates a beam sweeping through control signals of different numerologies.
- [0020] Figure 10 is a diagram that illustrates a Sub-band allocation to a UE to limit the search space for control signaling.
- [0021] Figure 11 is a diagram that illustrates a Sub-band allocation to common control signaling.
- [0022] Figure 12 is a diagram that illustrates Sub-band operation for shared channel.
- [0023] Figure 13 is a diagram that illustrates UL operation of UE within allocated subbands.
- [0024] Figure 14 is a diagram that illustrates Front Loaded DM-RS pattern multiple ports may be supported using OCC.
- [0025] Figure 15 is a diagram that illustrates a DM-RS placement in center symbols of the transmission time
- [0026] Figure 16 is a diagram that illustrates DM-RS for higher mobility scenarios should be spread over time.
- [0027] Figure 17 is a diagram that illustrates DM-RS sharing between two sub-frames for low mobility, high throughput scenarios. Figure 17A illustrates sharing between two subframes of the same user. Figure 17B illustrates sharing between sub-frames of two different users who are precoded the same way.
- [0028] Figure 18 is a diagram that illustrates two bundled PRBs undergoing the same precoding may have different DM-RS patterns.
- [0029] Figure 19 is a diagram that illustrates TRS assigned in specific resources across the available bandwidth.
- [0030] Figure 20 is a diagram that illustrates tracking RS is configured independently for each UE. Figure 20A illustrates no TRS is allocated. Figure 20B illustrates multiple resources allocated for TRS in frequency. Figure 20C illustrates higher density of TRS assigned in time.

- [0031] Figure 21 is a diagram that illustrates sub-bands with different numerologies support NR-SRS resources corresponding to their respective numerologies
- [0032] Figure 22 is a diagram that illustrates fixed numerology for NR-SRS resources.
- [0033] Figure 23 is a diagram that illustrates NR-SRS signaled with different numerologies with reserved resources in time duration T.
- [0034] Figure 24 is a diagram that illustrates NR-SRS in different beams.
- [0035] Figure 25 is a diagram that illustrates antenna virtualization and port mapping.
- [0036] Figure 26 is a diagram that illustrates NR-SRS transmission port mapping.
- [0037] Figure 27 is a diagram that illustrates NR SRS beam sweeping block and burst.
- [0038] Figure 28 is a diagram that illustrates CSI-ICM Configuration Procedure Example.
- [0039] Figure 29 is a diagram that illustrates CSI-RS Measurement Activation/Deactivation MAC Control Element of one octet.
- [0040] Figure 30 is a diagram that illustrates CSI-RS Measurement Activation/Deactivation MAC Control Element of k (k=4) octets.
- [0041] Figure 31 is a diagram that illustrates one or several NR-PUSCHs are scheduled for CSI measurement reporting.
- [0042] Figure 32 is a diagram that illustrates one NR-PUSCH and or several NR-PUCCHs are scheduled for CSI measurement reporting.
- [0043] Figure 33 is a diagram that illustrates several NR-PUCCHs are scheduled for CSI measurement reporting.
- [0044] Figure 34 is a diagram that illustrates several NR-PUCCHs are scheduled for CSI measurement reporting.
- [0045] Figure 35 is a diagram of a Graphical User Interface of one embodiment.
- [0046] Figure 36A illustrates one embodiment of an example communications system in which the methods and apparatuses described and claimed herein may be embodiment.
- [0047] Figure 36B is a block diagram of an example apparatus or device configured for wireless communications in accordance with the embodiments illustrated herein.
- [0048] Figure 36C is a system diagram of the RAN and the core network according to an embodiment.
- [0049] Figure 36D is a system diagram of the RAN and the core network according to another embodiment.
- [0050] Figure 36E is a system diagram of the RAN and the core network according to yet another embodiment.

[0051] Figure 36F is a block diagram of an exemplary computing system in which one or more apparatuses of the communications networks illustrated in Figures 36A, 36C, 36D and 36E may be embodied.

#### **DETAILED DESCRIPTION OF ILLUSTRATIVE EMBODIMENTS**

[0052] A detailed description of the illustrative embodiment will be discussed in reference to various figures, embodiments and aspects herein. Although this description provides detailed examples of possible implementations, it should be understood that the details are intended to be examples and thus do not limit the scope of the application.

[0053] Reference in this specification to “one embodiment,” “an embodiment,” “one or more embodiments,” “an aspect” or the like means that a particular feature, structure, or characteristic described in connection with the embodiment is included in at least one embodiment of the disclosure. Moreover, the term “embodiment” in various places in the specification is not necessarily referring to the same embodiment. That is, various features are described which may be exhibited by some embodiments and not by the other.

[0054] Generally, the application is directed to methods and systems for reference signal designs and control channel designs for NR systems. In order to meet the requirements of the NR systems, enhancements related to reference signal and control channel design for NR can be employed. The application is also directed to mechanisms for control channel designs including techniques to assign resources for NR-DCI and waveforms for UL signaling. Mechanisms to aid control channel estimation and allocation of UL and DL resources within sub-bands can limit the computational burden on the UE.

[0055] Another aspect of the application is directed to mechanisms for reference signal designs. Solutions for DMRS and TRS design for NR are employed. Mechanisms can support resource allocation and cell/beam wide RS allocation and UE-specific RS allocation.

[0056] Resource allocation for NR-SRS in multiple beams and across multiple numerologies are described. Precoded SRS can be supported. Mechanisms for CSI based measurements are described. The following methods can enable CSI ICM and can make it more efficient: (i) A new RRC signaling, informs the UE about necessary information of configuration, such as RS location, code book information; (ii) a CSI-ICM resource set where CSI-ICM resources within the set may be dynamically shared among UEs. A two-step CSI-ICM configuration to support CSI-ICM and reduce the latency. Step 1 is to pre-configure a set of K CSI-ICM resources for all the UEs through RRC signaling. In step 2, for a given UE, dynamically indicate N ( $N \geq 1$ ) CSI-ICM resources from a total of K based on the interference hypothesis to enable CSI-ICM measurement by dynamic signaling through DCI or dynamic signaling through MAC CE.

**[0057]** According to another embodiment, group-based CSI-ICM configuration through DCI is used to enable multiple UEs measuring the interference channel. The UEs can be grouped by experiencing the same interference hypothesis. According to yet another embodiment, a new NR PUCCH format to support CSI-ICM reporting is envisaged. In yet another embodiment, a new NR DCI design is envisaged to enable UE interference cancellation for MU-MIMO. In yet another embodiment, a procedure of interference channel measurement and interference cancellation for NR MU-MIMO is described.

**[0058]** According to another aspect, mechanisms for dynamic CSI-RS resource allocation are described. Two methods for RRC based configuration of CSI-RS pooling resources are envisaged. In the first technique, a UE-specific CSI-RS resources configuration is employed without configuration of a group of UEs sharing the same CSI-RS resource pool. In a second technique, a UE-specific CSI-RS resources configuration is employed with configuration of a group of UEs sharing the same CSI-RS resource pool.

**[0059]** Several signaling designs to dynamically indicate UE's CSI-RS resource and reporting are described (i) CSI measurement command signaled in MAC CE; and (ii) CSI measurement command signaled in DCI including: (a) CSI measurement command piggyback on DCI; (b) Standalone CSI measurement command (sent on a separate DCI) for a specific UE; and (c) Group-based DCI to schedule multiple UEs' CSI-RS measurement and feedback.

**[0060]** The mechanisms discussed herein may be conducted at the NR-node, Transmission and Reception Point (TRP) or Remote Radio Head (RRH). Accordingly, it is envisaged that the NR-node, TRP and RRH are interchangeable even though the NR-node is used in most exemplary descriptions or illustrations.

**[0061]** The time interval contains DL and/or UL transmissions are flexible for different numerologies and RAN slices and may be statically or semi-statically configured. The time interval structure may be used for a slot or a mini-slot within a subframe. The mechanisms for this time interval structure may be applicable to slot and/or mini-slot even though the exemplary descriptions and/or illustration figures use slot or mini-slot.

#### Acronyms

**[0062]** The following acronyms are used for the terms and phrases below:

AR	Augmented Reality
AS	Access Stratum
BF-RS	BeamForm Reference Signal
BT-RS	Beamformed Training Reference Signal
CE	Control Element

CoMP	Coordinated Multipoint
CP	Cyclic Prefix
CQI	Channel Quality Indication
CRS	Cell-specific Reference Signals
CSI	Channel State Information
CSI-RS	Channel State Information Reference Signals
CSI-ICM	Channel State Information – Interference Channel Measurement
DCI	Downlink Control Information
DL	DownLink
DM-RS	Demodulation Reference Signals
eMBB	enhanced Mobile Broadband
eNB	evolved Node B
ePDCCH	Enhanced Physical Downlink Control Channel
FD	Full-Dimension
FDD	Frequency Division Duplex
FFS	For Further Study
GUI	Graphical User Interface
HARQ	Hybrid Automatic Repeat Request
ID	Identification
IMT	International Mobile Telecommunications
KP	Kronecker-Product
KPI	Key Performance Indicators
LTE	Long Term Evolution
MAC	Medium Access Control
MCL	Maximum Coupling Loss
MCS	Modulation and Coding Scheme
MME	Mobility Management Entity
MIMO	Multiple-Input and Multiple-Output
NAS	Non-Access Stratum
NB	Narrow Beam
NDI	New Data Indicator
NEO	Network Operation
NR-Node	New Radio-Node
OCC	Orthogonal Cover Codes

OFDM	Orthogonal Frequency Division Multiplexing
PDCCH	Physical Downlink Control Channel
PDSCH	Physical Downlink Shared Channel
PMI	Precoder Matrix Indication
PRS	Positioning Reference Signals
PUSCH	Physical Uplink Shared Channel
PUCCH	Physical Uplink Control Channel
RAT	Radio Access Technology
RB	Resource Block
RE	Resource Element
RI	Rank Indication
RRC	Radio Resource Control
RRH	Remote Radio Head
RS	Reference Signal
RSSI	Received Signal Strength Indicator
RSRP	Reference Signal Received Power
RSRQ	Reference Signal Received Quality
RV	Redundancy Version
SC-FDMA	Single Carrier-Frequency Division Multiple Access
SI	System Information
SIB	System Information Block
SISO	Single-Input and Single-Output
SRS	Sounding Reference Signal
2D	Two-Dimensional
3D	Three-Dimensional
TDD	Time Division Duplex
TPC	Transmit Power Control
TRP	Transmission and Reception Point
TRS	Tracking Reference Signal
TTI	Transmission Time Interval
TXSS	Transmit Sector Sweep
UAV	Unmanned Aerial Vehicle
UE	User Equipment
UL	UpLink

URLLC	Ultra-Reliable and Low Latency Communications
VR	Virtual Reality
WB	Wide Beam
WRC	Wireless Planning Coordination

#### Reference Signals in LTE

**[0063]** DL Reference Signals (RS)s are predefined signals occupying specific Resource Elements (RE)s within the downlink time-frequency RE grid. The LTE specification includes several types of DL RSs transmitted in different ways for different purposes [E. Dahlman, S. Parkvall, J. Skold, “4G LTE/LTE-Advanced for Mobile Broadband,” second edition, 2014].

**[0064]** *Cell-specific Reference Signals (CRS)*: CRS are used: (1) by User Equipments (UEs) for channel estimation for coherent demodulation of DL physical channels; and (2) by UEs to acquire Channel State Information (CSI); (3) by UEs for measurements of cell-selection and handover.

**[0065]** *Demodulation Reference Signals (DM-RS)*: DM-RS are referred to as UE-specific reference signals, and are (1) used for channel estimation by a specific UE and only transmitted within the RBs specifically assigned for PDSCH/ePDCCH transmission to that UE, and (2) associated with data signals and precoded prior to the transmission with the same precoder as data.

**[0066]** *Channel State Information Reference Signals (CSI-RS)*: CSI-RS are intended to be used by UEs to acquire CSI for channel-dependent scheduling, link adaptation and multi-antenna transmissions.

#### Uplink Reference Signals

**[0067]** Similar to LTE DL, reference signals are also used in LTE UL. Two types of reference signals are defined for LTE UL [“4G LTE/LTE-Advanced for Mobile Broadband”].

**[0068]** *UL Demodulation Reference Signals (DM-RS)*: DM-RS is used by the base station for channel estimation for coherent demodulation of Physical Uplink Shared Channel (PUSCH) and Physical Uplink Control CHannel (PUCCH). DM-RS are only transmitted within the RBs specifically assigned for PUSCH/PUCCH transmission and are spanning the same frequency range as the corresponding physical channel.

**[0069]** *UL Sounding Reference Signals (SRS)*: SRS is used by the base station for CSI estimation for supporting uplink channel-dependent scheduling and link adaptation. SRS are also used for the base station to obtain CSI estimation for DL under the case of channel reciprocity.

### CSI Feedback in LTE

[0070] DL channel-dependent scheduling is a key feature of LTE, which selects the DL transmission configuration and related parameters depending on the instantaneous DL channel condition, including the interference situation. To support the DL channel-dependent scheduling, a UE provides the CSI to the evolved Node B (eNB). The eNB uses the information for its scheduling decisions.

[0071] The CSI consists of one or several pieces of information [“4G LTE/LTE-Advanced for Mobile Broadband”] including:

[0072] *Rank Indication (RI)*: provide a recommendation on the transmission rank to use or, number of preferred layers that should be used for PDSCH transmission to the UE.

[0073] *Precoder Matrix Indication (PMI)*: indicate a preferred precoder to use for PDSCH transmission.

[0074] *Channel-Quality Indication (CQI)*: represent the highest modulation-and-coding scheme to achieve a block-error probability of at most 10%.

[0075] Together, a combination of the RI, PMI, and CQI forms a CSI feedback report to eNB. What is included in the CSI report depends on the UE’s configured reporting mode. For example, RI and PMI do not need to be reported unless the UE is in a spatial multiplexing multi-antenna transmission mode.

### Downlink Control Information

[0076] The Downlink Control Information (DCI) is a predefined format in which the DCI is formed and transmitted in Physical Downlink Control Channel (PDCCH). The DCI format tells the UE how to get its data which is transmitted on Physical Downlink Shared Channel (PDSCH) in the same subframe. It carries the details for the UE such as number of resource blocks, resource allocation type, modulation scheme, redundancy version, coding rate, etc., which help UE find and decode PDSCH from the resource grid. There are various DCI formats used in LTE in PDCCH.

### New Radio (NR) Frame Structure

[0077] Currently, 3GPP standardization efforts are underway to define the NR frame structure. Consensus is to build the so called ‘self-contained’ time intervals for NR. As illustrated in Figure 1, a self-contained time interval is understood to contain the control information for a grant, the data and it’s acknowledgement (i.e. ACK/NACK) all within a time interval and is expected to have configurable UL/DL/side link allocations and reference signals within its resources [3GPP R1-164694 Frame Structure Requirements, Qualcomm, May 2016].

New Radio Requirements

[0078] 3GPP TR 38.913 [3GPP TR 38.913 Study on Scenarios and Requirements for Next Generation Access Technologies; (Release 14), V0.2.0] defines scenarios and requirements for New Radio (NR) technologies. The Key Performance Indicators (KPIs) for eMBB, URLLC and mMTC devices are summarized in Table 1 below.

Device	KPI	Description	Requirement
URLLC	Control Plane Latency	Control plane latency refers to the time to move from a battery efficient state (e.g., IDLE) to start of continuous data transfer (e.g., ACTIVE).	10 ms
	Data Plane Latency	For URLLC the target for user plane latency <i>for UL and DL</i> . Furthermore, if possible, the latency should also be low enough to support the use of the next generation access technologies as a wireless transport technology that can be used within the next generation access architecture.	0.5 ms
	Reliability	Reliability can be evaluated by the success probability of transmitting X bytes <sup>NOTE1</sup> within 1 ms, which is the time it takes to deliver a small data packet from the radio protocol layer 2/3 SDU ingress point to the radio protocol layer 2/3 SDU egress point of the radio interface, at a certain channel quality (e.g., coverage-edge). NOTE1: Specific value for X is FFS.	1-10 <sup>-5</sup> within 1 ms.
mMTC	Coverage	"Maximum coupling loss" (MCL) in uplink and downlink between device and Base Station site (antenna connector(s)) for a data rate of [X bps], where the data rate is observed at the egress/ingress point of the radio protocol stack in uplink and downlink.	164 dB
	UE Battery Life	User Equipment (UE) battery life can be evaluated by the battery life of the UE without recharge. For mMTC, UE battery life in extreme coverage shall be based on the activity of mobile originated data transfer consisting of [200 bytes] Uplink (UL) per day followed by [20 bytes] Downlink (DL) from Maximum Coupling Loss (MCL) of [tbd] dB, assuming a stored energy capacity of [5Wh].	15 years
	Connection Density	Connection density refers to total number of devices fulfilling specific Quality of Service (QoS) per unit area (per km <sup>2</sup> ). QoS definition should take into account the amount of data or access request generated within a time t_gen that can be sent or received within a given time, t_sendrx, with x% probability.	10 <sup>6</sup> devices/km <sup>2</sup>

**Table 1**

Reference Signal Definition for NR

[0079] The following has been agreed upon at the 3GPP RAN1 #86bis meeting for the NR Reference Signal (RS) supported for downlink:

- [0080] *CSI-RS*: Reference signal with main functionalities of CSI acquisition, beam management.
- [0081] *FFS*: RRM measurement
- [0082] *DM-RS*: Reference signal with main functionalities of data and control demodulation
- FFS: channel state information estimation and interference estimation
  - FFS: beam management
- [0083] *Reference signal for phase tracking*
- FFS: Whether DM-RS extension can be applied or not
  - FFS whether new RS or RS for other functionalities can be used
- [0084] *Reference signal for time/freq. tracking*
- FFS whether new RS or RS for other functionalities can be used
- [0085] *Reference signal for Radio link monitoring*
- FFS whether new RS or RS for other functionalities can be used
- [0086] *RS for RRM measurement*
- FFS whether new RS or RS for other functionalities can be used
- [0087] At least the following RSs are supported for NR uplink:
- [0088] *SRS*: Reference signal with main functionalities of CSI acquisition, beam management
- FFS: RRM measurement
- [0089] *DM-RS*: Reference signal with main functionalities of data and control demodulation
- FFS: beam management
- [0090] *Reference signal for phase tracking*
- FFS: Whether DM-RS extension can be applied or not
  - FFS whether new RS or RS for other functionalities can be used
- [0091] *FFS*: Reference signal for RRM measurement
- FFS whether new RS or RS for other functionalities can be used

CSI Feedback in LTE

[0092] DL channel-dependent scheduling is a key feature of LTE, which selects the DL transmission configuration and related parameters depending on the instantaneous DL channel condition, including the interference situation. To support the DL channel-dependent scheduling,

UE provides the CSI to the evolved Node B (eNB). The eNB uses the information for its scheduling decisions.

[0093] The CSI consists of one or several pieces of information: (i) Rank Indication (RI); (ii) Precoder Matrix Indication (PMI); (iii) Channel-Quality Indication (CQI). Together, a combination of the RI, PMI, and CQI forms a CSI feedback report to eNB. What is included in the CSI report depends on the UE’s configured reporting mode. CSI report could be configured to be periodic or aperiodic by RRC signaling.

Aperiodic CSI Reporting using PUSCH

[0094] Aperiodic reporting is triggered by DCI formats, and could be used to provide more detailed reporting via PUSCH. A UE is semi-statically configured by higher layer to feedback CQI and PMI and corresponding RI on the same PUSCH using one of the following CSI reporting modes given in Table 1 below. In sub-frame n, a CSI request can be transmitted in DCI format 0 and DCI format 4, which schedule a PUSCH transmission that carry aperiodic CSI report in sub-frame n+k.

		PMI Feedback Type		
		No PMI	Single PMI	Multiple PMI
PUSCH CQI Feedback Type	Wideband (wideband CQI)	Mode 1-0	Mode 1-1	Mode 1-2
	UE Selected (subband CQI)	Mode 2-0		Mode 2-2
	Higher Layer-configured (subband CQI)	Mode 3-0	Mode 3-1	Mode 3-2

**Table 2**

[0095] For each of the transmission modes in Table 2 above, different reporting modes are defined and supported on PUSCH.

Periodic CSI Reporting using PUCCH

[0096] For periodic CSI reporting, UE is semi-statically configured by higher layers to periodically feedback different CSI components (CQI, PMI, and/or RI) on the PUCCH using the reporting modes given in Table 3. The periodic CSI reporting is configured by higher layer signaling (RRC).

		PMI Feedback Type	
		No PMI	Single PMI
PUCCH CQI Feedback Type	Wideband (wideband CQI)	Mode 1-0	Mode 1-1
	UE Selected (subband CQI)	Mode 2-0	Mode 2-1

**Table 3**

[0097] For each of the transmission modes defined in Table 3 above, different periodic CSI reporting modes are defined and supported on PUCCH.

Mechanisms for Control Channel Designs

[0098] According to an aspect of the application, architectures and techniques for DL and UL control signals for NR are provided. Solutions are described herein for resource allocation and reference signal design for NR-DCI.

[0099] In one embodiment, NR-DCI resource allocation in a beam centric architecture is described. Here, the 3GPP spec can support transmission of NR-DCI on multiple beams to improve coverage and reliability. Note that LTE supported only broadcast of the PDCCH. The beams may sweep through different spatial locations carrying NR-DCI as shown in Figure 2.

[00100] In this proposal, the beams carrying control information sweep through the space before the UL/DL grant resources are made available as shown in Figure 2. The DL grant is available N symbols after the control signaling. The advantage of this scheme is that latency is reduced in decoding important control signaling related to paging, RACH, etc.

[00101] If the UE location is known a-priori, its UE-specific NR-DCI can be transmitted only in a subset of the beams. If the UE location is not known to the NR-Node, its NR-DCI may be transmitted in every beam. This concept is illustrated in Figures 3A and 3B where the control region is swept by 4 beams covering symbol per beam. A UE-specific NR-DCI is repeated in all the beams in Figure 3A but transmitted only in beams 1 and 2 in Figure 3B. The NR-DCI may be located in different subcarriers in different beams.

[00102] Similarly, NR-DCI for common control signaling may be carried in every beam. The common control search space uses the same subcarriers in all the beams carrying the control information – minimizes the overhead to indicate different common control signaling resources for each beam.

[00103] In another embodiment, each beam may carry multiple symbols including control and data as shown in Figure 4 where the NR-DCI in the beam may allocate resources for an UL and/or DL grant in the same beam. The advantage of this scheme is that the latency between the control and data is minimal. Generally, for the schemes described above, control and data

transmission could occur in different beams, For example, beams for control signaling may be wider than those for data signaling.

**[00104]** According to another embodiment, solutions for RS design for NR are proposed. Certain types of NR-DCI such as common control signals may be transmitted for beam-wide reception. The NR-DCI can leverage the beam-RS which is intended for identifying a beam and for measurements of a beam for also estimating the channel.

**[00105]** If NR-DCI is transmitted through multiple ports (as in transmit diversity) a new form of “Control-RS” with appropriate density may be introduced to aid channel estimation of NR-DCI. This control-RS would be transmitted for each port that is supported for NR-DCI transmission. This control-RS may be cell/beam specific and its location and resources may depend on one or more of the following: (i) Cell ID; and (ii) Beam ID.

**[00106]** The control-RS may be transmitted to cover channel estimation for the entire frequency range of the DCI symbols or may be transmitted in a limited region where DCIs transmitted with those ports are mapped in frequency.

**[00107]** Figure 5 illustrates the beam-RS and control-RS ports. The control-RS may be defined for more than 1 port. The resources for multiple ports may be defined with orthogonal covering codes similar to the OCCs for DMRS ports in LTE.

**[00108]** Certain types of NR-DCI, especially UE-specific signals may be precoded to improve spatial separation and coverage. For such use cases, “control-DMRS” may be introduced to aid in channel estimation.

**[00109]** Figure 6 shows a Control DMRS used in UE-specific manner to decode the NR-DCI. The NR-DCI may be transmitted on multiple ports (transmit diversity or beamforming) and correspondingly the control-DMRS would be precoded similar to the precoded NR-DCI and will be supported on the ports used for data transmission. If the data and control are transmitted on the same beam, they may share the control-RS or control-DMRS resources.

**[00110]** Figure 7 shows a control DMRS shared between control and data region if they are precoded in the same way. The beam-RS, control-RS and control-DMRS can be located in close proximity to the control region to provide high control channel reliability.

**[00111]** According to yet another embodiment, the NR-DCI may use a fixed number of control signals or fixed duration for control signaling in every transmission interval. This could be a slot or mini-slot or subframe. For such a design, NR does not need to transmit a PCFICH-like channel as the control signaling resource is fixed. The control signaling resource may be indicated through critical system information such as the MIB or SIB1/SIB2 or may be set to fixed values in the spec.

**[00112]** Figure 8 shows an example where the number of control signals is the same in every transmission interval. Figure 9 shows an example where the duration of the control signaling is the same for all numerologies multiplexed in FDM/TDM in the resource grid. So a transmission interval using 60 KHz subcarrier spacing uses 4 symbols for control signaling whereas a transmission interval operating at 15 KHz uses 1 symbol for control signaling within that transmission interval. This solution ensures that the beams sweeps in every direction for the same period of time.

**[00113]** Alternatively, the spec may specify the number of symbols for each numerology. The number of symbols may depend on one or more of the following: (i) center frequency; (ii) bandwidth; and (iii) number of beams supported.

**[00114]** According to a further embodiment, NR has support for large bandwidths exceeding 80 MHz. If a UE is required to blindly decode the NR-DCI across the entire bandwidth it will experience significant latency and battery drain. As a result, NR must allow transmission of the NR-DCI to a UE in specific subbands. The UE must be configured to have knowledge of the resources of these subbands.

**[00115]** The UE-specific NR-DCI may be indicated within a limited number of resources (subbands) which are known apriori at the UE. The subbands may be configured semi-statically through RRC and MAC CE updates. Figure 10 shows an example where the NR-DCI is carried in UE-specific subbands. The subbands may be allocated based on UE capabilities, i.e. the UE may inform the network about the maximum bandwidth that it can process at a time. Note that the subbands allocated to a UE need not be contiguous in frequency.

**[00116]** The search space for common control signaling may carry NR-DCI such as those for paging, RACH response, etc. be limited to specific subbands so that UEs do not have to blindly decode all the resources in the common control signaling search space.

**[00117]** The common control signaling search space may be partitioned into multiple search spaces and UE may be assigned to search for the common NR-DCI only within a subset of those search spaces. Figure 11 shows an example where the common signaling search space is partitioned into 4 search spaces and a UE is configured to search for its common NR-DCI only within 2 of those spaces.

**[00118]** Similar to the solution described above for subband operation for UE-specific and common NR-DCI, Physical DL shared channel (NR-PDSCH) carrying the data may also be restricted to subbands. This limits the number of times the UE's front end has to be re-tuned to a new frequency for reception. The subbands for NR-PDSCH may be semi-statically configured through RRC and MAC CE updates. Figure 12 shows an example where the NR-PDSCH for a

UE is transmitted over preconfigured subbands; so the UE is tuned to perform reception of data only over the range of frequencies covering the subbands.

**[00119]** According to a further embodiment, the UE may be configured to transmit within a subband rather than the entire bandwidth to limit the amount of front end and receiver processing. Accordingly the UL resources would be constrained within a subband. The subband may be preconfigured semi-statically through RRC or MAC CE updates or specified dynamically through the UL grant.

**[00120]** Figure 13 shows example of resource allocation for UL transmission for CP-OFDM or DFTS-OFDM within a subband. Here one or more subbands are allocated to the UE within which the UE is provided its UL grant. Similarly, for UL grantless transmission, a subband of frequencies may be indicated to a UE to transmit its grantless signal. When resource hopping is used, the UE may transmit within one or more subbands and the hopping resources may not occupy the entire bandwidth.

**[00121]** In an embodiment, it is envisaged that the waveform (CP-OFDM or DFT-S-OFDM) is assigned to a UE by the network. Here, the NR-Node makes the decision for the UE on which waveform to use. NR-Node can decide the waveform for the UE based on feedback from UE (such as beam or cell measurements or CQI) or from SRS or other RS on the UL. The configuration of the waveform may be done in the following ways:

**[00122]** 1. Dynamically through DL-control signaling (DCI/PDCCH) (DCI may support multiple formats which may explicitly indicate the waveform or the DCI may have to be blindly decoded for either possibility of the waveform); and

**[00123]** 2. Semi-static through RRC and MAC CE

#### Mechanisms for Reference Signal Designs

**[00124]** According to another aspect of the application, it is envisaged to support a wide range of user mobility scenarios with low-latency in NR, reference signaling may be enhanced in DL NR. DM-RS location within a slot/mini-slot or subframe should be flexible and adaptive to scenario-specific performance requirements. For example, Figure 2 shows that DM-RS could be front-loaded, bringing two-fold advantages. Firstly, the proximity of DM-RS to control data allows accurate estimation channel at control data resources, thereby rendering accurate demodulation/decoding of control data. Secondly, an early DM-RS will minimize the delay in demodulation/decoding by delivering channel estimates early on. These two advantages make it very suitable for the use case of URLL.

**[00125]** Figure 14 shows support for two ports via OCC. In general support for N-layers can be achieved via appropriate codes. Figures 3 to 5 further show three examples of suggested

placement of DM-RS. Figure 15 shows that DM-RS may be placed in the middle of a transmission interval so that channel estimates obtained over the entire duration of the interval are more accurate compared to having front-loaded DM-RS. Although the latency is higher for decoding control information, mMTC and eMBB may be able to tolerate the latency.

**[00126]** Figure 16 shows DMRS allocated with higher density in the transmission interval. For example, for high Doppler scenarios, the DM-RS may be allocated in multiple symbols spread over time, to enable accurate channel estimation.

**[00127]** For a scenario where the UEs have low mobility, the DM-RS could be placed at the end of a minislot 'i', and be used to provide channel estimates to subframes 'i' and 'i+1'. Similarly, DM-RS can be shared between multiple UEs. For UEs 1 and 2 that have consequent RBs in the same band, the DM-RS could be placed at the end of subframe '1', and be used to provide channel estimates to two subframes belonging to different users. Figure 17 illustrates the aforementioned scenarios.

**[00128]** In Figure 17, DM-RS is shared between two sub-frames for low mobility, high throughput scenarios: (a) Sharing between two subframes of the same user; and (b) Sharing between subframes of two different users precoded the same way.

**[00129]** NR can support PRB bundling and allow flexible location of DMRS resources in the bundled PRBs. In Figure 18, two bundled PRBs with different DM-RS patterns undergo the same precoding. PRB1 may have the DMRS allocated in a manner where it can be shared with a neighboring UE. But PRB 2 may have lower density of DMRS allocation.

**[00130]** The resource assignment of DM-RS can be either dynamic or semi-static. Dynamic signaling can be done through DCI. The specification may specify a list of possible DM-RS patterns (locations and sequences) out of which one may be assigned to a UE. The assigned resource may be indicated through an index into the list. When semi-static signaling is used, RRC or MAC CE updates will indicate the DM-RS configurations. It is envisaged the DM-RS will in general have same numerology as data.

**[00131]** In an embodiment, Tracking Reference Signals (TRS) for phase tracking in NR is described. Here, phase noise increases with increasing carrier frequency, thereby making it an important issue to solved in NR. The following solutions address phase tracking in NR.

**[00132]** TRS may not be sent all the time. Tracking RS need only be sent when needed and not always. This is important to avoid costly transmission overhead brought by TRS transmission. One or more of the following factors may influence the choice of switching TRS on or off:

**[00133]** *Modulation order*: The absence of phase tracking RS will have a much more deteriorating effect on BLER when data is higher order modulated compared to when it is lower order modulated.

**[00134]** *Carrier frequency*: Increasing carrier frequency will necessitate the need turn on Tracking RS.

**[00135]** *UE speed*: Increasing UE speed will increase the Doppler implying the need to turn on Tracking RS.

**[00136]** *Sub-carrier Spacing*: Increased sub-carrier spacing will increase inherent immunity of system to carrier frequency offset, thereby reducing the need for Tracking RS.

**[00137]** TRS may be UE specific or cell specific. On/Off signaling for tracking RS may be done via distinct signaling depending on whether it is UE specific or cell-specific. If it is UE specific then it may be configured via RRC signaling and turned on/off through RRC signaling/MAC CE updates or dynamically through the DCI. If TRS is cell/beam wide then system information may be used to signal its presence and resources.

**[00138]** Figure 19 shows the cell/beam wide case where TRS resources are assigned in specific locations in the grid. Enough TRS resources may be reserved so that UEs that may operate only in certain subbands of available spectrum can access the TRS. Figure 20 shows the UE specific case where each UE can have TRS resources assigned according to its SNR, modulation, numerology, etc.

**[00139]** In case of UE specific TRS, tracking RS may be precoded. In addition, location and sequence of Tracking RS may depend on one or more of beam ID, cell ID, and UE specific resources, such as for example, a root/shift of a sequence assigned to the UE or location of the DL resources for the UE.

**[00140]** In case of cell/beam wide TRS, TRSs are transmitted in resources that are known to all UEs. TRSs could be a function of one or more of: (a) Cell ID; and (b) Beam ID. TRS transmission could be configured on one or more ports. In some instances, it may be sufficient to track phase by transmitting TRS on a single port. As a result, TRS on a single port may be supported by default. However, NR must also support more ports for TRS. The resources for the ports may be configured for both cell/beam wide and UE specific use cases through DCI or RRC signaling.

**[00141]** According to yet another embodiment, NR Sounding reference signal on UL (NR-SRS) is described. Since NR will support different numerologies, NR-SRS numerology and resources must be allocated in a manner compatible with all supported data and control signal numerologies and TDM/FDM multiplexing of multiple users. The following solutions can

address NR-SRS signaling aspects when multiple numerologies are supported simultaneously in a carrier. NR-SRS resource signaling may fall into one of the categories described below where the NR-Node can allocate any of the following resources for NR-SRS transmission:

**[00142]** 1. Certain OFDM symbols or portions of the OFDM symbols may be reserved in a cell-wide or beam-wide manner for transmitting NR-SRS in each supported numerology. In Figure 21, the network divides the transmission BW into two numerologies. Numerology 1 supports 15 KHz subcarrier spacing and Numerology 2 supports 60 KHz subcarrier spacing. Within the bandwidth assigned to each numerology, NR-SRS transmission will have the same numerology.

**[00143]** 2. Certain OFDM symbols or portions of the OFDM symbols may be reserved in a cell-wide or beam-wide manner in a reference numerology that may be associated to the carrier frequency or indicated by the system information. This concept is illustrated in Figure 22 where SRS is always transmitted at fixed numerology although other signaling may occur in other numerologies. Figure 22 shows that NR-SRS is transmitted over 1 symbol corresponding to Numerology 1. The specific numerology can be assigned via either semi-static configuration such as RRC signaling or dynamic assigned by DL DCI.

**[00144]** Alternatively, the SRS resources may be defined in units of time and may be configured to support any numerology. In this case, the reserved time may carry a different number of NR-SRS symbols for different numerologies. This concept is illustrated in Figure 23 where NR-SRS resource is reserved for a fixed duration T. Different numerologies may be used within this duration, for example, 1 symbol of NR-SRS at 15 KHz subcarrier spacing (Numerology 1), or 2 symbols of NR-SRS at 60 KHz subcarrier spacing (Numerology 2).

**[00145]** In an embodiment, a UE may transmit NR-SRS on multiple beams in a reserved SRS resource. This concept is illustrated in Figure 24. Each NR-SRS symbol is reserved for a certain beamforming direction. It is envisaged that these solutions can apply to a self-contained subframe as well.

**[00146]** In another embodiment, SRS port mapping techniques may be used to support non-precoded, precoded and beamforming. The NR-SRS port mapping methods for non-precoded, precoded, and beamforming cases are described.

**[00147]** In an exemplary embodiment, the UE may transmit a maximum number of ports that it can support and feedback to NR-NB. The maximum number of available, supported ports may be dependent on UE capability. Here, a unified method for NR-SRS port mapping for non-precoded, precoded and beamforming can be employed. The porting mapping can work with the UL antenna virtualization. The antenna virtualization method is depicted in the following Figure

25. The antenna virtualization can be partitioned into four stages. The first stage performs digital precoding or beamforming via generation of  $V_D$ . After applying antenna virtualization, the effective precoding/beamforming matrix/vector  $V$  from Figure 25 can be expressed as:

$$V = V_T V_P V_A V_D, \quad \text{Eq. 1}$$

where the  $V_D$  is the codebook that can be defined or specified in the digital domain,  $V_A$  is the codewords to port mapping matrix, the  $V_P$  is the port to TXRU mapping matrix and  $V_T$  is the TXRU to physical antenna mapping.

**[00148]** If there is no precoding or beamforming applied on the NR SRS, then the NR SRS can be directly transmitted via the port configured/assigned from NR gNB. In other words, the  $V_D$ ,  $V_P$  and the  $V_T$  can be set as an identity matrix, and the  $V_A$  is dependent on the NR-SRS port configuration setting. For example, if a UE can support up to 8 ports and the RRC configuration parameters `srs-TxAntennaPorts` is set to {1, 2, 3, 4}, then UE can transmit NR-SRS to ports 1, 2, 3 and 4. The active port number may be dynamic signaling via DL DCI. In an instance, if the configuration parameter `srs-TxAntennaPorts` is set to {1, 2, 3, 4} and NR configure the transmission active port as {1, 3, 4} at a certain SRS transmission subframe then the UE transmit the NR-SRS on port {1, 3, 4} only. If there is no DL DCI is involved in the transmission port configuration then the UE can transmit the NR-SRS based on the RRC configuration ports setup. The NR-SRS transmit at the different port may be transmitted at the same or different CP-OFDM/DFT-S-OFDM symbol and can be associated with a specific numerology. In Figure 26, NR-SRS set up at different transmission port is configured to transmit at different CP-OFDM/DFT-S-OFDM symbol.

**[00149]** Similarly, when there is a precoded or beamforming involved in the NR-SRS, the  $V_D$ ,  $V_P$  and  $V_T$  can be properly design to meet the precoding or beamforming requirement. The  $V_A$  can be decided from the SRS port mapping configuration. In short, the following NR-SRS port mapping methods can be used:

**[00150]** 1. NR-SRS set up at the different transmission port may be configured to transmit at different CP-OFDM/DFT-S-OFDM symbol and can be associated with a specific numerology

**[00151]** 2. The port mapping can be either semi-static configured via RRC or dynamic configured via DL control.

**[00152]** Here, the  $V_P$  and the  $V_T$  can leave to UE implementation and without standardization effort.

**[00153]** According to yet a further embodiment, NR-SRS beam sweeping can be treated as a unit of beam sweeping time for transmitting NR-SRS. Each NR-SRS beam sweeping block may include at least one or more CP-OFDM/DTF-S-OFDM symbols and be associated with a specific numerology. Multiple beam sweeping blocks can form a beam sweeping burst. This is shown in Figure 27. The NR-SRS beam sweeping burst can be either configured as periodic or aperiodic transmission via semistatic RRC signaling or dynamic configuration via DL DCI. The SRS beam sweeping block can be associated with a single beam or multiple beams.

#### NR CSI Interference Channel Measurement

**[00154]** According to yet another aspect of the application, solutions to support CSI-ICM in NR are envisaged. In one embodiment, a new RRC signaling is employed to signal to the CSI-ICM. In another embodiment, two-step dynamic signaling is described. In yet another embodiment, a group based CSI-ICM configuration through DCI is described. In yet a further embodiment, the PUCCH format for CSI-ICM reporting is described. In yet even a further embodiment, the DCI design enables UE interference cancellation for MU-MIMO. In even a further embodiment, procedures of interference channel measurement and interference cancellation is described below.

**[00155]** According to this aspect, a new information element *CSI-ICM-Config* is used as the only signaling to indicate all the necessary information of the configuration is described. For example, the NR node configured the UE using the RRC signaling with the CSI-RS/ICM location. This could be based on one or more of the following: (i) UE interference hypotheses, (ii) the number of interference channel; and (iii) multiuser MIMO scheduling. Meanwhile, the information of precoding matrix used in the CSI-ICM transmission also need to be indicated. This is because the UE want to measure the real interference channel, so the precoding matrix need to be removed from the effective channel and the interference channel information can be feedback to the NR node. An example of CSI-ICM configuration information element *CSI-ICM-Config* in the RRC configuration message is listed below as follows:

```
-- ASN1START
CSI-ICM-Config ::= SEQUENCE {
  csi-ICM-ConfigId      CSI-ICM-ConfigId,
  resourceConfig       INTEGER (0..maxNumberOfResourceConfig),
  subframeConfig       INTEGER (0..maxNumberOfSubframeConfig),
  pmiConfig            INTEGER (0..maxNumberOfPMIConfig),
}
-- ASN1STOP
```

[00156] Alternatively, the technique may implement the CSI-ICM configuration by two steps signaling via NR DCI to avoid the large latency issue introduced by the RRC only signaling method. The steps are as follows:

[00157] Step 1: Initial resource set configuration through RRC signaling. Here, a set of K CSI-ICM resources are pre-configured for all the UEs through RRC information element *CSI-ICMset-Config* to indicate all the available CSI-RS/ICM location used for CSI\_ICM. An example of information element *CSI-ICMset-Config* in the RRC message is listed as follows.

```

-- ASN1START
CSI-ICMset-Config ::= SEQUENCE {
    csi-ICMset-list      CSI-ICMset-List,
    CSI-ICMset-List ::= SEQUENCE (size 1.. maxNumberOfcsi-ICM-ConfigId) of csi-ICM-ConfigId
}
-- ASN1STOP
    
```

[00158] Step 2: Dynamic CSI-ICM configuration signaling through NR DCI. Here, for a given UE, the NR node indicates N out of K (where  $N \geq 1$ ) of the CSI-ICM resources from the set based on the interference hypothesis to enable CSI-ICM by dynamic signaling through a configurable DCI or dynamic signaling through MAC CE. The value of N increases as the number of interference sources increases. By introducing the second step, it can reduce the latency in the CSI-ICM configuration comparing to the RRC only signaling. For each UE in different interference hypotheses, the DCI information may be different, in terms of the number of the CSI-ICM resources and location, CSI-ICM feedback configuration and UL resources to transmit the CSI-ICM feedback if applicable. An example of the configurable fields for DCI scheme are listed in Table 4 below. One or more or all of the fields may be used to configure the DCI.

Field Element	Meaning of each Field
UE ID	Identification of the UE, which is scrambled in CRC parity bits.
CSI-ICM resource indication	CSI-ICM configuration (indicates number of the resource, location, antenna ports or the source of the

	interference channel.)
CSI-ICM feedback Configuration	NR PUCCH Format for CSI-ICM feedback and other information
CSI-RS resource indication	CSI-RS configuration
CSI-IM resource indication	CSI-IM configuration
CSI feedback configuration	NR PUCCH Format for CSI feedback and other information
UL resources indication	UL resources used to transmit the CSI-RS/CSI-ICM feedback
...	

**Table 4**

**[00159]** As an alternative method, the dynamic CSI-ICM configuration can be also done through MAC Control Element (CE) once the resources set is pre-configured. A new MAC Control Element, CSI-ICM configuration MAC control element which carries the similar information as that defined in Table 1 is defined below:

**[00160]** The CSI-ICM configuration MAC control element may be defined over a fixed number  $n$  of octets. The CSI-ICM configuration MAC control element may be identified with Logical Channel Identifier (LCID), which may be one of the existing reserved value of LTE downlink logical channels between the range 01011 and 10111 (binary coding) or alternatively the LTE logical channel value ranges may be extended with new defined values assigned to CSI-ICM configuration MAC CE.

**[00161]** As discussed above, the DCI needs to be transmitted to every UE separately to indicate the CSI-ICM configuration which requires a large number of DCI transmission when there are a lot of UEs. To reduce this overhead, group-based CSI-ICM configuration can be used through DCI to enable multiple UEs measuring the interference channel. The UEs that have the same interference sources or share some resources when doing the CSI-ICM can be grouped and transmitted in one DCI containing the common information and the individual information to all the UEs in the group. The common information is the shared fields that are the same to all UEs in the group, in terms of group ID, CSI-ICM configuration, CSI-RS/ICM structure and etc. The individual information indicates the UE ID, UL resources to transmit the CSI-ICM feedback and all the other signaling cannot be shared among the UEs within the group which each UE has its

unique information. An example of the configurable fields for group-base CSI-ICM configuration DCI scheme are listed in Table 5 below.

Field Element	Meaning of each Field
Group ID	Identification of the group
CSI-ICM resources indication	CSI-ICM configuration (indicates number of the resource, location, antenna ports or the source of the interference channel.)
CSI-ICM feedback indication	NR PUCCH Format for CSI-ICM feedback and other information
CSI-RS resource indication	CSI-RS configuration
CSI-IM resource indication	CSI-IM configuration
CSI feedback configuration	NR PUCCH Format for CSI feedback and other information
UE ID 1	UE 1's index in the group
UL resources indication 1	UL resources used to transmit the CSI-ICM feedback for UE 1
UE ID 2	UE 2's index in the group
UL resources indication 2	UL resources used to transmit the CSI-ICM feedback for UE 2
...	

**Table 5**

**[00162]** According to another embodiment, upon measuring the interference channel, the UE needs to feedback the interference channel estimation to NR node/TRP. This will be used in MU-MIMO scheduling. The interference channel feedback could be implicit, explicit or a combination of implicit and explicit feedbacks. For example, when the largest eigenvalue is less than a pre-defined threshold, only the implicit feedback is required, and otherwise, the UE needs to feedback the explicit channel measurement according to the eigenvalues greater than the threshold. The implicit feedback may contain information such as CQI, PMI or RI for the

interference channel, and explicit feedback may be in the following forms: (i) The exact interference channel measurement; (ii) The eigenvectors of the interference channel according to the largest eigenvalues; and (iii) The covariance matrix of the interference channel.

**[00163]** To reduce the overhead of the explicit interference feedback, it could be quantized by a pre-defined codebook or transformed to a reduced-dimension form. The CSI-ICM feedback may be tolerant to a higher quantization error or a transforming error comparing to explicit CSI feedback.

**[00164]** A UE is configured by higher layer or NR DCI to periodically or aperiodically or semi-persistently send CSI-ICM feedback via NR PUCCH. A new NR PUCCH reporting type could be defined for CSI-ICM feedback. For periodic CSI-ICM feedback, the periodicity and relative offset are configured by higher layer signaling. For aperiodic or semi-persistent CSI-ICM, the resource to transmit CSI-ICM feedback is configured by NR DCI.

**[00165]** According to yet another embodiment, after receiving the CSI and CSI-ICM feedbacks, the NR node could be able to schedule MU-MIMO transmission. For the UE scheduled for MU-MIMO, beside the general transmission information such as resource allocation, Modulation and coding scheme, and HARQ process number, the NR DCI should also include the following information:

**[00166]** 1. *Antenna port indices*: The antenna port index could be signaled to the UE implicitly or explicitly. For implicit signaling, a set of limited configurations of these parameters could predefined in the standard specification or configured by higher layer signaling, and then in the NR DCI format only the index of the selected configurations is signaled.

**[00167]** 2. *Precoding/decoding matrix information*: It could include information such as codebook index for the precoding matrix, PMI, or index of the suggested decoding matrix. With the help of this information, the UE is able to cancel the interference transmitted to other co-scheduled UEs or from other beams/TRPs.

**[00168]** According to another embodiment, procedures of interference channel measurement and interference cancellation are described. These include, for example:

**[00169]** 1. NR node first configures the UEs for CSI-RS and CSI-ICM via RRC signaling or NR DCI/MAC CE.

**[00170]** 2. Based on the CSI-RS and CSI-ICM configurations, the UE measures the desired channel and interference channel.

[00171] 3. The UE transmits the CSI and CSI-ICM feedbacks to NR node, where the feedbacks could be implicit, explicit or a combination of implicit and explicit feedbacks.

[00172] 4. NR node schedules MU-MIMO transmission based the CSI and CSI-ICM feedbacks, and sends scheduling decision and transmission information to the UEs via NR DCI, which includes the information such as antenna port indices and precoding/decoding matrix information.

[00173] Based on the information from its NR DCI, the UE is able to cancel the interference transmitted to other co-scheduled UEs or from other beams/TRPs.

[00174] A call flow to portray the CSI-ICM procedure is illustrated in Figure 28.

#### Dynamic CSI Measurement and Report

[00175] According to a further aspect of the application, a semi-static RRC configuration of CSI measurement and the pool of CSI-RS resource element for the UE, and dynamic signaling to schedule CSI measurement are described. Two methods for RRC based configuration of CSI-RS pooling resources.

[00176] *Method 1:* UE-specific CSI-RS resources configuration, without configuration of a group of UEs sharing the same CSI-RS resource pool. The NR node (e.g., gNB) configures the UE with a set of K CSI-RS resources using dedicated RRC message (e.g., like RRCConnectionReconfiguration message or NR RRC equivalent). The UE uses the CSI-RS configuration to identify CSI-RS resources used for channel state measurement. The NR node may signal to the UE the exact CSI-RS to use from the configured set via MAC CE signaling or DCI signaling. The configuration set the NR node configures the UE with may include one or more of the parameters:

[00177] *A.* The antenna port count i.e. the number of antenna ports to be used for the transmission of the CSI-RS. The antenna port count to be used for CSI-RS may be numerology specific.

[00178] *B.* The CSI RS mapping to resource element configuration. The CSI RS mapping to resource element may be numerology specific.

[00179] *C.* The CSI RS transmission interval configuration (for e.g. could be in terms of subframe configuration) which may indicate the period and the time interval (e.g. subframe) offset (within the CSI-RS period) for the occurrence of the CSI reference signals. The time interval offset specified the exact time interval of subframe within the CSI-RS transmission periodicity for the transmission of the CSI-RS. The CSR-RS transmission time interval of subframe configuration may be numerology specific.

[00180] *D.* Beam configuration in DL and as well beam configuration in UL for reporting of measurements performed of the CSI-RS.

[00181] *E.* For each of the configuration parameters above, the configuration may be predefined (for e.g. in the specification) and only the index to these predefined configurations are signaled to the UE.

[00182] *F.* It should be noted that even if each terminal is provided through dedicated RRC signaling with terminal specific CSI-RS resource configuration, the network may still configured more than one UE with the same set of CSI-RS resources.

[00183] *G.* By default, the set of CSI-RS pre-configured in the UE by the NR node via RRC signaling are not activated i.e. the UE doesn't perform measurement on these CSI-RS. The UE performs measurements on these CSI-RS upon CSI-RS measurement activation command from NR node through MAC CE signaling of physical layer DCI signaling.

[00184] *Method 2:* UE-specific CSI-RS resources configuration, with configuration of a group of UEs sharing the same CSI-RS resource pool. In this embodiment, the NR node may limit CSI-RS configuration related signaling overhead by using group configuration. In addition to the parameters used in Method 1, the configuration set the NR node configures the UE with may include one or more of the parameters:

[00185] *A.* A UE Group identity

[00186] *B.* UE's position or index within this group.

[00187] *C.* NR node may configure each UE, for e.g. at the time of UE configuration with dedicated signaling bearers (e.g. SRB1 or SRB2 or NR equivalent) or at the time of UE configuration with dedicated radio bearers, with a UE group identity for e.g. a group RNTI (Radio Network Temporary Identifier). The group RNTI is use to address the resources/location of the CSI-RS configuration for the specific group of UEs configured with this group RNTI. The group RNTI may be mapped to the DL-SCH (Downlink Shared Channel) transport channel, a multi-cast logical channel or similar NR transport channel. The UE monitors the transmission of this group RNTI from the NR node. Upon detection of this group RNTI, the UE uses the group RNTI to search and decode the associated CSI-RS configuration.

[00188] *D.* For each configured group, all UEs in this group are arranged in an order. UE's position or index within this group is basically UE's order in the group, which can be used by group-based DCI (using group RNTI) to identify a UE in a signaling-efficient manner. For example, consider a group # 3 with UEs 2, 77, 105, 269. Then, UE's position or index within the group 3 are 1, 2, 3, 4 for UEs 2, 77, 105, 269, respectively.

**[00189]** In one embodiment, the NR node may initially signals the CSI-RS configuration to the UE in dedicated UE RRC signaling as described in the embodiment above and then subsequently uses the group signaling to configure group of UEs with a common pool of CSI-RS resources.

**[00190]** According to another embodiment, a detailed design of CSI-RS Pooling DCI or MAC CE Signaling is described. Several signaling designs include: (i) CSI measurement command signaled in DCI; and (ii) CSI measurement command signaled in MAC CE

**[00191]** *MAC CE based signaling.* In an embodiment, the following method can be used to signal CSI measurement command in MAC CE. Specifically, the NR node dynamically signals in MAC CE to the UE, transmission of CSI-RS preconfigured by RRC signaling. The indication of CSI-RS transmission in MAC CE may include the CSI-RS configuration index previously pre-configured in the UE (for e.g. via RRC signaling). The UE uses this index to locate the CSI-RS configuration information stored in its internal database. The UE may then perform measurement of the CSI-RS using the CSI-RS configuration parameters (e.g. antenna port count, resource information, CSI-RS transmission interval information, beam configuration) identified by the information (e.g. CSI-RS configuration index) received in the MAC CE.

**[00192]** In an exemplary embodiment, the MAC CE may carry in addition to the CSI-RS configuration index, the measurement time window. The measurement time windows may be pre-defined in the specification. It may be expressed in terms of an integer number of CSI-RS transmission time interval (e.g. CSI transmission periodicity time value), for e.g. 1,2,3,4 etc. For example, if the measurement time window is 1, the UE measures CSI-RS over one CSI-RS transmission time interval and stop. Similarly, if the measurement time window is k, the UE measures CSI-RS over k CSI-RS transmission time intervals. In this embodiment, the NR node doesn't signals a MAC CE to the UE in order to terminate the CSI-RS measurement. The UE implicitly terminates the measurement using the received transmission time window.

**[00193]** In another embodiment, the NR node may explicitly signal to the UE in MAC CE, the termination (or de-activation) or a previously activated CSI-RS measurement. This may be the case, if the NR node didn't include in the prior CSR-RS measurement activation MAC CE, a measurement time window information. An example of CSI-RS measurement activation and deactivation MAC CE are depicted in Figure 17 and Figure 18. The MAC CE may be defined over a fixed number n of octets. The transmission MAC CE may be identified by a MAC PDU subheader with Logical Channel Identifier (LCID) as defined later below.

**[00194]** Two examples of MAC CE are illustrated below. The CSI RS measurement Activation/Deactivation MAC control element with one octet is defined in Figure 17. It has a fixed size and consists of a single octet containing some RS-fields part and some TW field where

TW encodes the measurement Time Window while the RS fields encode the activation or deactivation of CSI-RS measurement. Similarly, an example of Activation/Deactivation MAC control element of k octets with k=4 as an example is defined in Figure 18. It has a fixed size and consists of a k octets containing RS-fields part and TW field part. The RS field is set to "1" to indicate that the CSI-RS configuration identified by configuration index i shall be activated. The RSi field is set to "0" to indicate that the CSI-RS configuration identified by configuration index i shall be deactivated.

**[00195]** The MAC CE as illustrated includes only one measurement time window TW. This means the measurement time window is common for all the CSI-RS configuration included in the MAC CE. However, the MAC CE may also be structure to include more than one TW. For example, assuming each of the CSI RS included in the MAC CE has different TW, then there will be as many TWs as RSs in the MCA CE.

**[00196]** Figure 29 illustrates CSI-RS Measurement Activation/Deactivation MAC Control Element of one octet. Figure 30 illustrates CSI-RS Measurement Activation/Deactivation MAC Control Element of k (k=4) octets.

**[00197]** The logical channel ID associated with the CSI-RS measurement activation/deactivation MAC CEs may be one of the existing reserved value of LTE downlink logical channels between the range 01011 and 10111 (binary coding). Alternatively, the LTE logical channel value ranges may be extended with new defined values assigned to CSI-RS measurement activation/deactivation MAC CE. The logical channel ID should uniquely identify the MAC CE. For e.g., the MAC CE in two figure above should have different logical channel IDs. The signalling described for MAC CE can be applicable to the DCI based signaling as well.

**[00198]** According to another embodiment, the following DCI based signaling methods can include: (i) CSI measurement command piggyback on DCI; (ii) Standalone CSI measurement command (sent on a separate DCI) for a specific UE; and (iii) Group-based DCI to schedule multiple UEs' CSI-RS measurement and feedback.

**[00199]** In Signaling Method 1, CSI measurement command is piggybacked on another DCI using one or both of the following options:

**[00200]** 1. CSI measurement command is signaled in a DCI that is used for scheduling of NR-PUSCH. In addition, such a DCI may schedule one or several PUSCHs in different sub-frames, which will carry UL, control information of CSI measurement.

[00201] 2. CSI measurement command is signaled in a DCI that is used for scheduling of NR-PDSCH. Such a DCI may schedule one or several PUCCHs in different sub-frames will carry UL control information of CSI measurement.

[00202] According to Option 1, the CSI measurement command is signaled in a DCI that is used for scheduling of NR-PUSCH, so called UL grant DCI. It will carry the following information (explicitly or implicitly):

[00203] A. CSI request: for example 1 bit field to indicate if CSI measurement and report is set to triggered.

[00204] B. CSI-RS resources indication. This is an indication of N out of K (where  $N \geq 1$ ) of the CSI-RS resources from the set of resources configured by RRC signaling. This can be signaled by bitmap or other methods.

[00205] C. Antenna ports to CSI-RS resource elements mapping:

[00206] 1. This information can be signaled in several ways or implicitly signaled

[00207] 2. If the design of CSI-RS allows different density of CSI-RS for antenna ports at different measurement instances, then the information of the number of antenna ports should be signaled. For example, if a subset of indicated CSI-RS resources can be used interpreted as either for 4 or 8 CSI-RS ports, then 1 bit signaling should be used to indicate number of antenna ports.

[00208] 3. If the design of CSI-RS allows only fixed density of CSI-RS for antenna ports at different measurement instances, then the UE can infer the information of the number of antenna ports from the set of CSI-RS resources.

[00209] D. Location/indices of RBs where the UE should receive its CSI-RS and perform channel or interference measurement.

[00210] 1. If this field is omitted, the UE will receive CSI-RS on all RBs in the cell.

[00211] 2. The indication of CSI-RS resources will be applied to all RBs locations indicated.

[00212] E. CSI measurement configuration to be used for the UE.

[00213] 1. Each CSI measurement configuration include a set of CSI measurement/feedback reporting parameters: measurement/feedback metrics (RI, PMI, CQI and etc.), whether the metric is wideband or sub-band measurement, the reporting frequency of each feedback metric, and relative time offset.

[00214] 2. One of the CSI measurement configuration is indicated in the DCI. Or the UE can be configured a subset of allowed CSI measurement configurations in the standards by higher layer signalings (such as RRC signaling). Then, one of the CSI measurement configuration subset is indicated in the DCI.

[00215] F. CSI measurement reporting, physical uplink channel and start time

**[00216]** 1. The number of CSI measurement reports to be transmitted in the uplink can be explicitly signaled or implicitly interfered from the CSI measurement configuration. For example, CSI measurement reporting signaling can indicate 2 report instances of CSI measurement type 3. If CSI measurement type 3 is carried on NR-PUSCH, it needs only 1 report; if carried on NR-PUCCH, it needs J NR-PUCCHs to carry one complete CSI report.

**[00217]** 2. The DCI can schedule several NR-PUSCHs in the subsequent sub-frames, each carry one complete CSI report (or part of it). Alternatively, such a DCI explicitly can schedule one NR-PUSCH, and several NR-PUCCHs in subsequent sub-frames. The indices of these sub-frames will be signaled.

**[00218]** 3. The NR-PUSCH resource allocation is included in the uplink grant DCI already. If several subsequent NR-PUSCHs are scheduled as well, they can have the same resource allocation or different resource allocation (extra signaling); If several subsequent NR-PUCCHs are scheduled, the NR-PUCCH index can be signaled implicitly from either the search space index of the uplink grant DCI or starting RB index of the RBs where the uplink grant DCI is transmitted.

**[00219]** 4. CSI measurement report starting time: signaled as an timing offset from the current sub-frame, where the range of the offset value is 0 to H sub-frames. The default value of the timing offset is zero. As shown in the figures below, when the offset is set to zero, the CSI measurement can be reported as early as the end of the NR-PUSCH scheduled by the uplink grant DCI in the beginning of the sub-frame (or the flexible time interval).

**[00220]** Figure 31 illustrates one or several NR-PUSCHs are scheduled for CSI measurement reporting.

**[00221]** Figure 32 illustrates one NR-PUSCH and or several NR-PUCCHs are scheduled for CSI measurement reporting.

**[00222]** According to Option 2, the CSI measurement command is signaled in a DCI that is used for scheduling of NR-PDSCH, which is the DL grant DCI. It will carry the following information (explicitly or implicitly) similar to Option 1, and will include the following additional fields.

**[00223]** G. CSI measurement reporting, physical uplink channel and start time

**[00224]** H. The number of CSI measurement reports to be transmitted in the uplink can be explicitly signaled or implicitly interfered from the CSI measurement configuration.

**[00225]** I. The DCI can schedule several NR-PUCCHs in the subsequent sub-frames, each carry one complete CSI report (or part of it). The indices of these sub-frames will be signaled.

**[00226]** J. The NR-PUCCH index can be signaled implicitly from either the search space index of the uplink grant DCI or starting RB index of the RBs where the uplink grant DCI is transmitted.

**[00227]** K. CSI measurement report starting time: signaled as a timing offset from the current sub-frame, where the range of the offset value is zero to H sub-frames. The default value of the timing offset is zero. As shown in the figures below, when the offset is set to zero, the CSI measurement can be reported as early as the PUCCH at the end of current sub-frame following the NR-PDSCH scheduled by the DL grant DCI.

**[00228]** Figure 33 illustrates several NR-PUCCHs are scheduled for CSI measurement reporting. The UE Procedures for Signaling method 1 (including options 1 and 2) are described below as follows:

**[00229]** Step 1: A UE that has CSI-RS pooling resources configured by higher layer signaling will monitor downlink NR-PDCCH search spaces to detect DCI.

**[00230]** Step 2: If it successfully detects a UL or DL grant DCI addressed to its C-RNTI or other format of UE ID, and the CSI request field is set to be “triggered” or “on”, then the UE will process the received CSI measurement command information.

**[00231]** Step 3: The UE will perform CSI measurement by processing the CSI-RS received in the resources indicated in the CSI measurement command according to the parameters in CSI-RS resource allocation field and location of RBs of these CSI-RS (optional). CSI measurement type (such as wideband CQI/PMI etc.) will be done according to the CSI measurement configuration parameter.

**[00232]** Step 4: The UE will report the CSI measurement to the gNB using the parameters in the “CSI measurement reporting, physical uplink channel and timing” field. For example, the UE will transmit its CSI measurement on NR-PUSCHs or NR-PUCCHs scheduled by the UL or DL grant DCI.

**[00233]** According to another embodiment, a standalone CSI measurement command can be transmitted on a separate DCI can be used to active a CSI measurement for a UE. Such a standalone CSI measurement command DCI will carry the following information (explicitly or implicitly) as in Option 1 of signaling method 1, and include the following additional fields:

**[00234]** A. UE ID, which can be implicitly signaled as using UE’s C-RNTI or other ID to scramble the CRC of the DCI.

**[00235]** B. No need to transmit the field of “CSI Request” as in Option 1 of signaling method 1.

**[00236]** C. CSI measurement reporting, physical uplink channel and start time

- [00237] 1. The number of CSI measurement reports to be transmitted in the uplink can be explicitly signaled or implicitly interfered from the CSI measurement configuration.
- [00238] 2. The DCI can schedule several NR-PUCCHs in the subsequent sub-frames, each carry one complete CSI report (or part of it). The indices of these sub-frames will be signaled.
- [00239] 3. The NR-PUCCH index can be signaled implicitly from either the search space index of the standalone CSI measurement DCI or starting RB index of the RBs where the standalone CSI measurement DCI is transmitted.
- [00240] 4. CSI measurement report starting time: signaled as a timing offset from the current sub-frame, where the range of the offset value is 0 to H sub-frames. The default value of the timing offset is zero. As shown in the figures below, when the offset is set to zero, the CSI measurement can be reported as early as the PUCCH in the current sub-frame as the CSI measurement DCI.
- [00241] Figure 34 illustrates several NR-PUCCHs are scheduled for CSI measurement reporting.
- [00242] According to yet a further embodiment, UE Procedures for Signaling method 2 are as follows:
- [00243] Step 1: A UE that has CSI-RS pooling resources configured by higher layer signaling will monitor downlink NR-PDCCH search spaces to detect DCI that has the format of standalone CSI measurement DCI.
- [00244] Step 2: If it detects a standalone CSI measurement DCI addressed to its C-RNTI or other format of UE ID, then the UE will process the received CSI measurement command information.
- [00245] Step 3: The UE will perform CSI measurement by processing the CSI-RS received in the resources indicated in the CSI measurement command according to the parameters in CSI-RS resource allocation field and location of RBs of these CSI-RS (optional). CSI measurement type (such as wideband CQI/PMI, etc.) will be done according to the CSI measurement configuration parameter.
- [00246] Step 4: The UE will report the CSI measurement to the gNB using the parameters in the “CSI measurement reporting, physical uplink channel and timing” field. For example, the UE will transmit its CSI measurement on NR-PUCCHs scheduled by the standalone CSI measurement DCI.
- [00247] Signaling Method 3 is described in accordance with a further embodiment. Here, a group-based CSI measurement DCI can be used to schedule CSI-RS measurement and feedback for multiple UEs. Group-based CSI measurement DCI can achieve reduced signaling

overhead when these UEs have the same CSI reporting configuration and share the same CSI-RS resource pool configured by higher layer signalings. Such a group-based CSI measurement DCI will carry the following information (explicitly or implicitly) similar to those in Option 1 of signaling method 1, except the following different fields:

**[00248]** A. *Group ID*: as described, such multiple UEs are already configured by higher layer signaling (such as RRC) to be in a group. Then, they can address their group ID or group-RNTI in the group-based CSI measurement DCI.

**[00249]** B. *Signaling of which UEs need to perform CSI measurement*: This can be done by a bitmap in order of UE's index/position within the group configured by higher layer signaling. For each UE that needs to perform CSI measurement, the corresponding position in the bitmap will be set to "1", otherwise it will be set to "0".

**[00250]** C. CSI-RS resources indication.

**[00251]** 1. UEs being indicated in the same CSI measurement DCI may have the same or different CSI-RS resource allocation. Both can be signaled by bitmap or other methods.

**[00252]** D. Antenna ports to CSI-RS resource elements mapping, which will be the same for all UEs in the CSI measurement DCI.

**[00253]** E. Signaling method can be the same as in Option 1 of signaling method 1.

**[00254]** F. Location/indices of RBs where the UE should receive its CSI-RS and perform channel or interference measurement, which will be the same for all UEs in the CSI measurement DCI.

**[00255]** 1. If this field is omitted, the UE will receive CSI-RS on all RBs in the cell.

**[00256]** 2. The indication of CSI-RS resources will be applied to all RBs locations indicated.

**[00257]** G. CSI measurement configuration to be used for the UE, which will be the same for all UEs in the CSI measurement DCI.

**[00258]** 1. Signaling method can be the same as in Option 1 of signaling method 1.

**[00259]** H. CSI measurement reporting, physical uplink channel and start time

**[00260]** 1. The number of CSI measurement reports to be transmitted in the uplink can be explicitly signaled or implicitly inferred from the CSI measurement configuration.

**[00261]** 2. The DCI can schedule several NR-PUCCHs in the subsequent sub-frames, each carry one complete CSI report (or part of it). The number of scheduled NR-PUCCHs will be the same for all UEs in the CSI measurement DCI. The indices of these sub-frames will be signaled may be the same for all UEs in the CSI measurement DCI, or different but scheduled in the time domain according to pre-defined pattern. For example, the NR-PUCCHs of the first UE is

scheduled in sub-frame 1, 5, 9; and the NR-PUCCHs of the second UE is scheduled in sub-frame 2, 6, 10; and so on.

**[00262]** 3. If NR-PUCCHs of different UEs are scheduled in different sub-frames, the NR-PUCCH index of each UE can be the same. For example, it can be signaled implicitly from either the search space index of the group-based CSI measurement DCI or starting RB index of the RBs where the group-based CSI measurement DCI is transmitted. If NR-PUCCHs of different UEs are scheduled in the same sub-frames, the NR-PUCCH index of each UE shall be different. For example, it can be signaled implicitly from either the search space index of the group-based CSI measurement DCI plus an offset value equals to the UE's index or position in the group or starting RB index of the RBs where the group-based CSI measurement DCI is transmitted plus an offset value equals to the UE's index or position in the group.

**[00263]** 4. CSI measurement report starting time: signaled as an timing offset from the current sub-frame, where the range of the offset value is 0 to H sub-frames. The default value of the timing offset is zero. As shown in the figures below, when the offset is set to zero, the CSI measurement can be reported as early as the PUCCH in the current sub-frame as the group-based CSI measurement DCI. CSI measurement report starting time may be the same for all UEs in the CSI measurement DCI, or different but scheduled in the time domain according to pre-defined pattern. For example, the offsets of the UEs are 1, 3, 5,... etc.

**[00264]** UE Procedures for Signaling method 2 are described below in accordance with a further embodiment as follows:

**[00265]** Step 1: A UE that has CSI-RS pooling resources configured by higher layer signaling will monitor downlink NR-PDCCH search spaces to detect DCI that has the format of group-based CSI measurement DCI.

**[00266]** Step 2: If it detects a group-based CSI measurement DCI addressed to its group RNTI or group Id (configured by higher layer signaling), then the UE will process the received CSI measurement command information.

**[00267]** Step 3: The UE will perform CSI measurement by processing the CSI-RS received in the resources indicated in the CSI measurement command according to the parameters in CSI-RS resource allocation field and location of RBs of these CSI-RS (optional). CSI measurement type (such as wideband CQI/PMI, etc.) is performed according to the CSI measurement configuration parameter.

**[00268]** Step 4: The UE will report the CSI measurement to the gNB using the parameters in the "CSI measurement reporting, physical uplink channel and timing" field. For example, the UE

will transmit its CSI measurement on NR-PUCCHs scheduled by the standalone CSI measurement DCI.

**[00269]** The signalings described for DCI based signaling in this section can be applicable to the MAC CE based signaling as well.

**[00270]**

**[00271]** It is understood that the functionality, steps, and configurations illustrated in Figures 1-34 may be implemented in or produced by the form of software (i.e., computer-executable instructions) stored in a memory of, and executing on a processor of, a wireless device or other apparatus (e.g., a server, gateway, device, or other computer system), such as one of those illustrated in Figures 36 B and F described below.

**[00272]** Interfaces, such as Graphical User Interfaces (GUIs), can be used to assist user to control and/or configure functionalities related to reference signals and control channels in NR. Figure 35 is a diagram that illustrates an interface 3502 that allows a user to input and view parameters corresponding to reference signals and control channels in NR. It is to be understood that interface 3502 can be produced using displays such as those shown in Figures 36 B and F described below.

**[00273]** The 3rd Generation Partnership Project (3GPP) develops technical standards for cellular telecommunications network technologies, including radio access, the core transport network, and service capabilities - including work on codecs, security, and quality of service. Recent radio access technology (RAT) standards include WCDMA (commonly referred as 3G), LTE (commonly referred as 4G), and LTE-Advanced standards. 3GPP has begun working on the standardization of next generation cellular technology, called New Radio (NR), which is also referred to as "5G". 3GPP NR standards development is expected to include the definition of next generation radio access technology (new RAT), which is expected to include the provision of new flexible radio access below 6 GHz, and the provision of new ultra-mobile broadband radio access above 6 GHz. The flexible radio access is expected to consist of a new, non-backwards compatible radio access in new spectrum below 6 GHz, and it is expected to include different operating modes that can be multiplexed together in the same spectrum to address a broad set of 3GPP NR use cases with diverging requirements. The ultra-mobile broadband is expected to include cmWave and mmWave spectrum that will provide the opportunity for ultra-mobile broadband access for, e.g., indoor applications and hotspots. In particular, the ultra-mobile broadband is expected to share a common design framework with the flexible radio access below 6 GHz, with cmWave and mmWave specific design optimizations.

**[00274]** 3GPP has identified a variety of use cases that NR is expected to support, resulting in a wide variety of user experience requirements for data rate, latency, and mobility. The use cases include the following general categories: enhanced mobile broadband (e.g., broadband access in dense areas, indoor ultra-high broadband access, broadband access in a crowd, 50+ Mbps everywhere, ultra-low cost broadband access, mobile broadband in vehicles), critical communications, massive machine type communications, network operation (e.g., network slicing, routing, migration and interworking, energy savings), and enhanced vehicle-to-everything (eV2X) communications. Specific service and applications in these categories include, e.g., monitoring and sensor networks, device remote controlling, bi-directional remote controlling, personal cloud computing, video streaming, wireless cloud-based office, first responder connectivity, automotive ecall, disaster alerts, real-time gaming, multi-person video calls, autonomous driving, augmented reality, tactile internet, and virtual reality to name a few. All of these use cases and others are contemplated herein.

**[00275]** Figure 36A illustrates one embodiment of an example communications system 100 in which the methods and apparatuses described and claimed herein may be embodied. As shown, the example communications system 100 may include wireless transmit/receive units (WTRUs) 102a, 102b, 102c, and/or 102d (which generally or collectively may be referred to as WTRU 102), a radio access network (RAN) 103/104/105/103b/104b/105b, a core network 106/107/109, a public switched telephone network (PSTN) 108, the Internet 110, and other networks 112, though it will be appreciated that the disclosed embodiments contemplate any number of WTRUs, base stations, networks, and/or network elements. Each of the WTRUs 102a, 102b, 102c, 102d may be any type of apparatus or device configured to operate and/or communicate in a wireless environment. Although each WTRU 102a, 102b, 102c, 102d is depicted in Figures 36A-36E as a hand-held wireless communications apparatus, it is understood that with the wide variety of use cases contemplated for 5G wireless communications, each WTRU may comprise or be embodied in any type of apparatus or device configured to transmit and/or receive wireless signals, including, by way of example only, user equipment (UE), a mobile station, a fixed or mobile subscriber unit, a pager, a cellular telephone, a personal digital assistant (PDA), a smartphone, a laptop, a tablet, a netbook, a notebook computer, a personal computer, a wireless sensor, consumer electronics, a wearable device such as a smart watch or smart clothing, a medical or eHealth device, a robot, industrial equipment, a drone, a vehicle such as a car, truck, train, or airplane, and the like.

**[00276]** The communications system 100 may also include a base station 114a and a base station 114b. Base stations 114a may be any type of device configured to wirelessly interface

with at least one of the WTRUs 102a, 102b, 102c to facilitate access to one or more communication networks, such as the core network 106/107/109, the Internet 110, and/or the other networks 112. Base stations 114b may be any type of device configured to wiredly and/or wirelessly interface with at least one of the RRHs (remote radio heads) 118a, 118b and/or TRPs (transmission and reception points) 119a, 119b to facilitate access to one or more communication networks, such as the core network 106/107/109, the Internet 110, and/or the other networks 112. RRHs 118a, 118b may be any type of device configured to wirelessly interface with at least one of the WTRUs 102c, to facilitate access to one or more communication networks, such as the core network 106/107/109, the Internet 110, and/or the other networks 112. TRPs 119a, 119b may be any type of device configured to wirelessly interface with at least one of the WTRUs 102d, to facilitate access to one or more communication networks, such as the core network 106/107/109, the Internet 110, and/or the other networks 112. By way of example, the base stations 114a, 114b may be a base transceiver station (BTS), a Node-B, an eNode B, a Home Node B, a Home eNode B, a site controller, an access point (AP), a wireless router, and the like. While the base stations 114a, 114b are each depicted as a single element, it will be appreciated that the base stations 114a, 114b may include any number of interconnected base stations and/or network elements.

**[00277]** The base station 114a may be part of the RAN 103/104/105, which may also include other base stations and/or network elements (not shown), such as a base station controller (BSC), a radio network controller (RNC), relay nodes, etc. The base station 114b may be part of the RAN 103b/104b/105b, which may also include other base stations and/or network elements (not shown), such as a base station controller (BSC), a radio network controller (RNC), relay nodes, etc. The base station 114a may be configured to transmit and/or receive wireless signals within a particular geographic region, which may be referred to as a cell (not shown). The base station 114b may be configured to transmit and/or receive wired and/or wireless signals within a particular geographic region, which may be referred to as a cell (not shown). The cell may further be divided into cell sectors. For example, the cell associated with the base station 114a may be divided into three sectors. Thus, in an embodiment, the base station 114a may include three transceivers, e.g., one for each sector of the cell. In an embodiment, the base station 114a may employ multiple-input multiple output (MIMO) technology and, therefore, may utilize multiple transceivers for each sector of the cell.

**[00278]** The base stations 114a may communicate with one or more of the WTRUs 102a, 102b, 102c over an air interface 115/116/117, which may be any suitable wireless communication link (e.g., radio frequency (RF), microwave, infrared (IR), ultraviolet (UV),

visible light, cmWave, mmWave, etc.). The air interface 115/116/117 may be established using any suitable radio access technology (RAT).

**[00279]** The base stations 114b may communicate with one or more of the RRHs 118a, 118b and/or TRPs 119a, 119b over a wired or air interface 115b/116b/117b, which may be any suitable wired (e.g., cable, optical fiber, etc.) or wireless communication link (e.g., radio frequency (RF), microwave, infrared (IR), ultraviolet (UV), visible light, cmWave, mmWave, etc.). The air interface 115b/116b/117b may be established using any suitable radio access technology (RAT).

**[00280]** The RRHs 118a, 118b and/or TRPs 119a, 119b may communicate with one or more of the WTRUs 102c, 102d over an air interface 115c/116c/117c, which may be any suitable wireless communication link (e.g., radio frequency (RF), microwave, infrared (IR), ultraviolet (UV), visible light, cmWave, mmWave, etc.). The air interface 115c/116c/117c may be established using any suitable radio access technology (RAT).

**[00281]** More specifically, as noted above, the communications system 100 may be a multiple access system and may employ one or more channel access schemes, such as CDMA, TDMA, FDMA, OFDMA, SC-FDMA, and the like. For example, the base station 114a in the RAN 103/104/105 and the WTRUs 102a, 102b, 102c, or RRHs 118a, 118b and TRPs 119a, 119b in the RAN 103b/104b/105b and the WTRUs 102c, 102d, may implement a radio technology such as Universal Mobile Telecommunications System (UMTS) Terrestrial Radio Access (UTRA), which may establish the air interface 115/116/117 or 115c/116c/117c respectively using wideband CDMA (WCDMA). WCDMA may include communication protocols such as High-Speed Packet Access (HSPA) and/or Evolved HSPA (HSPA+). HSPA may include High-Speed Downlink Packet Access (HSDPA) and/or High-Speed Uplink Packet Access (HSUPA).

**[00282]** In an embodiment, the base station 114a and the WTRUs 102a, 102b, 102c, or RRHs 118a, 118b and TRPs 119a, 119b in the RAN 103b/104b/105b and the WTRUs 102c, 102d, may implement a radio technology such as Evolved UMTS Terrestrial Radio Access (E-UTRA), which may establish the air interface 115/116/117 or 115c/116c/117c respectively using Long Term Evolution (LTE) and/or LTE-Advanced (LTE-A). In the future, the air interface 115/116/117 may implement 3GPP NR technology.

**[00283]** In an embodiment, the base station 114a and the WTRUs 102a, 102b, 102c, or RRHs 118a, 118b and TRPs 119a, 119b in the RAN 103b/104b/105b and the WTRUs 102c, 102d, may implement radio technologies such as IEEE 802.16 (e.g., Worldwide Interoperability for Microwave Access (WiMAX)), CDMA2000, CDMA2000 1X, CDMA2000 EV-DO, Interim Standard 2000 (IS-2000), Interim Standard 95 (IS-95), Interim Standard 856 (IS-856), Global

System for Mobile communications (GSM), Enhanced Data rates for GSM Evolution (EDGE), GSM EDGE (GERAN), and the like.

**[00284]** The base station 114c in Figure 36A may be a wireless router, Home Node B, Home eNode B, or access point, for example, and may utilize any suitable RAT for facilitating wireless connectivity in a localized area, such as a place of business, a home, a vehicle, a campus, and the like. In an embodiment, the base station 114c and the WTRUs 102e, may implement a radio technology such as IEEE 802.11 to establish a wireless local area network (WLAN). In an embodiment, the base station 114c and the WTRUs 102d, may implement a radio technology such as IEEE 802.15 to establish a wireless personal area network (WPAN). In yet an embodiment, the base station 114c and the WTRUs 102e, may utilize a cellular-based RAT (e.g., WCDMA, CDMA2000, GSM, LTE, LTE-A, etc.) to establish a picocell or femtocell. As shown in Figure 4A, the base station 114b may have a direct connection to the Internet 110. Thus, the base station 114c may not be required to access the Internet 110 via the core network 106/107/109.

**[00285]** The RAN 103/104/105 and/or RAN 103b/104b/105b may be in communication with the core network 106/107/109, which may be any type of network configured to provide voice, data, applications, and/or voice over internet protocol (VoIP) services to one or more of the WTRUs 102a, 102b, 102c, 102d. For example, the core network 106/107/109 may provide call control, billing services, mobile location-based services, pre-paid calling, Internet connectivity, video distribution, etc., and/or perform high-level security functions, such as user authentication.

**[00286]** Although not shown in Figure 36A, it will be appreciated that the RAN 103/104/105 and/or RAN 103b/104b/105b and/or the core network 106/107/109 may be in direct or indirect communication with other RANs that employ the same RAT as the RAN 103/104/105 and/or RAN 103b/104b/105b or a different RAT. For example, in addition to being connected to the RAN 103/104/105 and/or RAN 103b/104b/105b, which may be utilizing an E-UTRA radio technology, the core network 106/107/109 may also be in communication with another RAN (not shown) employing a GSM radio technology.

**[00287]** The core network 106/107/109 may also serve as a gateway for the WTRUs 102a, 102b, 102c, 102d, 102e to access the PSTN 108, the Internet 110, and/or other networks 112. The PSTN 108 may include circuit-switched telephone networks that provide plain old telephone service (POTS). The Internet 110 may include a global system of interconnected computer networks and devices that use common communication protocols, such as the transmission control protocol (TCP), user datagram protocol (UDP) and the internet protocol (IP) in the TCP/IP internet protocol suite. The networks 112 may include wired or wireless

communications networks owned and/or operated by other service providers. For example, the networks 112 may include another core network connected to one or more RANs, which may employ the same RAT as the RAN 103/104/105 and/or RAN 103b/104b/105 or a different RAT.

**[00288]** Some or all of the WTRUs 102a, 102b, 102c, 102d in the communications system 100 may include multi-mode capabilities, e.g., the WTRUs 102a, 102b, 102c, 102d, and 102e may include multiple transceivers for communicating with different wireless networks over different wireless links. For example, the WTRU 102e shown in Figure 4A may be configured to communicate with the base station 114a, which may employ a cellular-based radio technology, and with the base station 114c, which may employ an IEEE 802 radio technology.

**[00289]** Figure 36B is a block diagram of an example apparatus or device configured for wireless communications in accordance with the embodiments illustrated herein, such as for example, a WTRU 102. As shown in Figure 36B, the example WTRU 102 may include a processor 118, a transceiver 120, a transmit/receive element 122, a speaker/microphone 124, a keypad 126, a display/touchpad/indicators 128, non-removable memory 130, removable memory 132, a power source 134, a global positioning system (GPS) chipset 136, and other peripherals 138. It will be appreciated that the WTRU 102 may include any sub-combination of the foregoing elements while remaining consistent with an embodiment. Also, embodiments contemplate that the base stations 114a and 114b, and/or the nodes that base stations 114a and 114b may represent, such as but not limited to transceiver station (BTS), a Node-B, a site controller, an access point (AP), a home node-B, an evolved home node-B (eNodeB), a home evolved node-B (HeNB), a home evolved node-B gateway, and proxy nodes, among others, may include some or all of the elements depicted in Figure 36B and described herein.

**[00290]** The processor 118 may be a general purpose processor, a special purpose processor, a conventional processor, a digital signal processor (DSP), a plurality of microprocessors, one or more microprocessors in association with a DSP core, a controller, a microcontroller, Application Specific Integrated Circuits (ASICs), Field Programmable Gate Array (FPGAs) circuits, any other type of integrated circuit (IC), a state machine, and the like. The processor 118 may perform signal coding, data processing, power control, input/output processing, and/or any other functionality that enables the WTRU 102 to operate in a wireless environment. The processor 118 may be coupled to the transceiver 120, which may be coupled to the transmit/receive element 122. While Figure 36B depicts the processor 118 and the transceiver 120 as separate components, it will be appreciated that the processor 118 and the transceiver 120 may be integrated together in an electronic package or chip.

**[00291]** The transmit/receive element 122 may be configured to transmit signals to, or receive signals from, a base station (e.g., the base station 114a) over the air interface 115/116/117. For example, in an embodiment, the transmit/receive element 122 may be an antenna configured to transmit and/or receive RF signals. In an embodiment, the transmit/receive element 122 may be an antenna configured to transmit and/or receive RF signals. Although not shown in Figure 36A, it will be appreciated that the RAN 103/104/105 and/or the core network 106/107/109 may be in direct or indirect communication with other RANs that employ the same RAT as the RAN 103/104/105 or a different RAT. For example, in addition to being connected to the RAN 103/104/105, which may be utilizing an E-UTRA radio technology, the core network 106/107/109 may also be in communication with another RAN (not shown) employing a GSM radio technology.

**[00292]** The core network 106/107/109 may also serve as a gateway for the WTRUs 102a, 102b, 102c, 102d to access the PSTN 108, the Internet 110, and/or other networks 112. The PSTN 108 may include circuit-switched telephone networks that provide plain old telephone service (POTS). The Internet 110 may include a global system of interconnected computer networks and devices that use common communication protocols, such as the transmission control protocol (TCP), user datagram protocol (UDP) and the internet protocol (IP) in the TCP/IP internet protocol suite. The networks 112 may include wired or wireless communications networks owned and/or operated by other service providers. For example, the networks 112 may include another core network connected to one or more RANs, which may employ the same RAT as the RAN 103/104/105 or a different RAT.

**[00293]** Some or all of the WTRUs 102a, 102b, 102c, 102d in the communications system 100 may include multi-mode capabilities, e.g., the WTRUs 102a, 102b, 102c, and 102d may include multiple transceivers for communicating with different wireless networks over different wireless links. For example, the WTRU 102c shown in Figure 36A may be configured to communicate with the base station 114a, which may employ a cellular-based radio technology, and with the base station 114b, which may employ an IEEE 802 radio technology.

**[00294]** Figure 36B is a block diagram of an example apparatus or device configured for wireless communications in accordance with the embodiments illustrated herein, such as for example, a WTRU 102. As shown in Figure 36B, the example WTRU 102 may include a processor 118, a transceiver 120, a transmit/receive element 122, a speaker/microphone 124, a keypad 126, a display/touchpad/indicators 128, non-removable memory 130, removable memory 132, a power source 134, a global positioning system (GPS) chipset 136, and other peripherals 138. It will be appreciated that the WTRU 102 may include any sub-combination of the foregoing elements while remaining consistent with an embodiment. Also, embodiments

contemplate that the base stations 114a and 114b, and/or the nodes that base stations 114a and 114b may represent, such as but not limited to transceiver station (BTS), a Node-B, a site controller, an access point (AP), a home node-B, an evolved home node-B (eNodeB), a home evolved node-B (HeNB), a home evolved node-B gateway, and proxy nodes, among others, may include some or all of the elements depicted in Figure 36B and described herein.

**[00295]** The processor 118 may be a general purpose processor, a special purpose processor, a conventional processor, a digital signal processor (DSP), a plurality of microprocessors, one or more microprocessors in association with a DSP core, a controller, a microcontroller, Application Specific Integrated Circuits (ASICs), Field Programmable Gate Array (FPGAs) circuits, any other type of integrated circuit (IC), a state machine, and the like. The processor 118 may perform signal coding, data processing, power control, input/output processing, and/or any other functionality that enables the WTRU 102 to operate in a wireless environment. The processor 118 may be coupled to the transceiver 120, which may be coupled to the transmit/receive element 122. While Figure 36B depicts the processor 118 and the transceiver 120 as separate components, it will be appreciated that the processor 118 and the transceiver 120 may be integrated together in an electronic package or chip.

**[00296]** The transmit/receive element 122 may be configured to transmit signals to, or receive signals from, a base station (e.g., the base station 114a) over the air interface 115/116/117. For example, in an embodiment, the transmit/receive element 122 may be an antenna configured to transmit and/or receive RF signals. In an embodiment, the transmit/receive element 122 may be an emitter/detector configured to transmit and/or receive IR, UV, or visible light signals, for example. In yet an embodiment, the transmit/receive element 122 may be configured to transmit and receive both RF and light signals. It will be appreciated that the transmit/receive element 122 may be configured to transmit and/or receive any combination of wireless signals.

**[00297]** In addition, although the transmit/receive element 122 is depicted in Figure 36B as a single element, the WTRU 102 may include any number of transmit/receive elements 122. More specifically, the WTRU 102 may employ MIMO technology. Thus, in an embodiment, the WTRU 102 may include two or more transmit/receive elements 122 (e.g., multiple antennas) for transmitting and receiving wireless signals over the air interface 115/116/117.

**[00298]** The transceiver 120 may be configured to modulate the signals that are to be transmitted by the transmit/receive element 122 and to demodulate the signals that are received by the transmit/receive element 122. As noted above, the WTRU 102 may have multi-mode capabilities. Thus, the transceiver 120 may include multiple transceivers for enabling the WTRU 102 to communicate via multiple RATs, such as UTRA and IEEE 802.11, for example.

**[00299]** The processor 118 of the WTRU 102 may be coupled to, and may receive user input data from, the speaker/microphone 124, the keypad 126, and/or the display/touchpad/indicators 128 (e.g., a liquid crystal display (LCD) display unit or organic light-emitting diode (OLED) display unit). The processor 118 may also output user data to the speaker/microphone 124, the keypad 126, and/or the display/touchpad/indicators 128. In addition, the processor 118 may access information from, and store data in, any type of suitable memory, such as the non-removable memory 130 and/or the removable memory 132. The non-removable memory 130 may include random-access memory (RAM), read-only memory (ROM), a hard disk, or any other type of memory storage device. The removable memory 132 may include a subscriber identity module (SIM) card, a memory stick, a secure digital (SD) memory card, and the like. In an embodiment, the processor 118 may access information from, and store data in, memory that is not physically located on the WTRU 102, such as on a server or a home computer (not shown).

**[00300]** The processor 118 may receive power from the power source 134, and may be configured to distribute and/or control the power to the other components in the WTRU 102. The power source 134 may be any suitable device for powering the WTRU 102. For example, the power source 134 may include one or more dry cell batteries, solar cells, fuel cells, and the like.

**[00301]** The processor 118 may also be coupled to the GPS chipset 136, which may be configured to provide location information (e.g., longitude and latitude) regarding the current location of the WTRU 102. In addition to, or in lieu of, the information from the GPS chipset 136, the WTRU 102 may receive location information over the air interface 115/116/117 from a base station (e.g., base stations 114a, 114b) and/or determine its location based on the timing of the signals being received from two or more nearby base stations. It will be appreciated that the WTRU 102 may acquire location information by way of any suitable location-determination method while remaining consistent with an embodiment.

**[00302]** The processor 118 may further be coupled to other peripherals 138, which may include one or more software and/or hardware modules that provide additional features, functionality and/or wired or wireless connectivity. For example, the peripherals 138 may include various sensors such as an accelerometer, biometrics (e.g., finger print) sensors, an e-compass, a satellite transceiver, a digital camera (for photographs or video), a universal serial bus (USB) port or other interconnect interfaces, a vibration device, a television transceiver, a hands free headset, a Bluetooth® module, a frequency modulated (FM) radio unit, a digital music player, a media player, a video game player module, an Internet browser, and the like.

**[00303]** The WTRU 102 may be embodied in other apparatuses or devices, such as a sensor, consumer electronics, a wearable device such as a smart watch or smart clothing, a medical or eHealth device, a robot, industrial equipment, a drone, a vehicle such as a car, truck, train, or airplane. The WTRU 102 may connect to other components, modules, or systems of such apparatuses or devices via one or more interconnect interfaces, such as an interconnect interface that may comprise one of the peripherals 138.

**[00304]** Figure 36C is a system diagram of the RAN 103 and the core network 106 according to an embodiment. As noted above, the RAN 103 may employ a UTRA radio technology to communicate with the WTRUs 102a, 102b, and 102c over the air interface 115. The RAN 103 may also be in communication with the core network 106. As shown in Figure 36C, the RAN 103 may include Node-Bs 140a, 140b, 140c, which may each include one or more transceivers for communicating with the WTRUs 102a, 102b, 102c over the air interface 115. The Node-Bs 140a, 140b, 140c may each be associated with a particular cell (not shown) within the RAN 103. The RAN 103 may also include RNCs 142a, 142b. It will be appreciated that the RAN 103 may include any number of Node-Bs and RNCs while remaining consistent with an embodiment.

**[00305]** As shown in Figure 4C, the Node-Bs 140a, 140b may be in communication with the RNC 142a. Additionally, the Node-B 140c may be in communication with the RNC 142b. The Node-Bs 140a, 140b, 140c may communicate with the respective RNCs 142a, 142b via an Iub interface. The RNCs 142a, 142b may be in communication with one another via an Iur interface. Each of the RNCs 142a, 142b may be configured to control the respective Node-Bs 140a, 140b, 140c to which it is connected. In addition, each of the RNCs 142a, 142b may be configured to carry out or support other functionality, such as outer loop power control, load control, admission control, packet scheduling, handover control, macro-diversity, security functions, data encryption, and the like.

**[00306]** The core network 106 shown in Figure 4C may include a media gateway (MGW) 144, a mobile switching center (MSC) 146, a serving GPRS support node (SGSN) 148, and/or a gateway GPRS support node (GGSN) 150. While each of the foregoing elements are depicted as part of the core network 106, it will be appreciated that any one of these elements may be owned and/or operated by an entity other than the core network operator.

**[00307]** The RNC 142a in the RAN 103 may be connected to the MSC 146 in the core network 106 via an IuCS interface. The MSC 146 may be connected to the MGW 144. The MSC 146 and the MGW 144 may provide the WTRUs 102a, 102b, 102c with access to circuit-switched networks, such as the PSTN 108, to facilitate communications between the WTRUs 102a, 102b, 102c and traditional land-line communications devices.

**[00308]** The RNC 142a in the RAN 103 may also be connected to the SGSN 148 in the core network 106 via an IuPS interface. The SGSN 148 may be connected to the GGSN 150. The SGSN 148 and the GGSN 150 may provide the WTRUs 102a, 102b, 102c with access to packet-switched networks, such as the Internet 110, to facilitate communications between and the WTRUs 102a, 102b, 102c and IP-enabled devices.

**[00309]** As noted above, the core network 106 may also be connected to the networks 112, which may include other wired or wireless networks that are owned and/or operated by other service providers.

**[00310]** Figure 36D is a system diagram of the RAN 104 and the core network 107 according to an embodiment. As noted above, the RAN 104 may employ an E-UTRA radio technology to communicate with the WTRUs 102a, 102b, and 102c over the air interface 116. The RAN 104 may also be in communication with the core network 107.

**[00311]** The RAN 104 may include eNode-Bs 160a, 160b, 160c, though it will be appreciated that the RAN 104 may include any number of eNode-Bs while remaining consistent with an embodiment. The eNode-Bs 160a, 160b, 160c may each include one or more transceivers for communicating with the WTRUs 102a, 102b, 102c over the air interface 116. In an embodiment, the eNode-Bs 160a, 160b, 160c may implement MIMO technology. Thus, the eNode-B 160a, for example, may use multiple antennas to transmit wireless signals to, and receive wireless signals from, the WTRU 102a.

**[00312]** Each of the eNode-Bs 160a, 160b, and 160c may be associated with a particular cell (not shown) and may be configured to handle radio resource management decisions, handover decisions, scheduling of users in the uplink and/or downlink, and the like. As shown in Figure 4D, the eNode-Bs 160a, 160b, 160c may communicate with one another over an X2 interface.

**[00313]** The core network 107 shown in Figure 4D may include a mobility management gateway (MME) 162, a serving gateway 164, and a packet data network (PDN) gateway 166. While each of the foregoing elements are depicted as part of the core network 107, it will be appreciated that any one of these elements may be owned and/or operated by an entity other than the core network operator.

**[00314]** The MME 162 may be connected to each of the eNode-Bs 160a, 160b, and 160c in the RAN 104 via an S1 interface and may serve as a control node. For example, the MME 162 may be responsible for authenticating users of the WTRUs 102a, 102b, 102c, bearer activation/deactivation, selecting a particular serving gateway during an initial attach of the WTRUs 102a, 102b, 102c, and the like. The MME 162 may also provide a control plane

function for switching between the RAN 104 and other RANs (not shown) that employ other radio technologies, such as GSM or WCDMA.

**[00315]** The serving gateway 164 may be connected to each of the eNode-Bs 160a, 160b, and 160c in the RAN 104 via the S1 interface. The serving gateway 164 may generally route and forward user data packets to/from the WTRUs 102a, 102b, 102c. The serving gateway 164 may also perform other functions, such as anchoring user planes during inter-eNode B handovers, triggering paging when downlink data is available for the WTRUs 102a, 102b, 102c, managing and storing contexts of the WTRUs 102a, 102b, 102c, and the like.

**[00316]** The serving gateway 164 may also be connected to the PDN gateway 166, which may provide the WTRUs 102a, 102b, 102c with access to packet-switched networks, such as the Internet 110, to facilitate communications between the WTRUs 102a, 102b, 102c and IP-enabled devices.

**[00317]** The core network 107 may facilitate communications with other networks. For example, the core network 107 may provide the WTRUs 102a, 102b, 102c with access to circuit-switched networks, such as the PSTN 108, to facilitate communications between the WTRUs 102a, 102b, 102c and traditional land-line communications devices. For example, the core network 107 may include, or may communicate with, an IP gateway (e.g., an IP multimedia subsystem (IMS) server) that serves as an interface between the core network 107 and the PSTN 108. In addition, the core network 107 may provide the WTRUs 102a, 102b, 102c with access to the networks 112, which may include other wired or wireless networks that are owned and/or operated by other service providers.

**[00318]** Figure 36E is a system diagram of the RAN 105 and the core network 109 according to an embodiment. The RAN 105 may be an access service network (ASN) that employs IEEE 802.16 radio technology to communicate with the WTRUs 102a, 102b, and 102c over the air interface 117. As will be further discussed below, the communication links between the different functional entities of the WTRUs 102a, 102b, 102c, the RAN 105, and the core network 109 may be defined as reference points.

**[00319]** As shown in Figure 36E, the RAN 105 may include base stations 180a, 180b, 180c, and an ASN gateway 182, though it will be appreciated that the RAN 105 may include any number of base stations and ASN gateways while remaining consistent with an embodiment. The base stations 180a, 180b, 180c may each be associated with a particular cell in the RAN 105 and may include one or more transceivers for communicating with the WTRUs 102a, 102b, 102c over the air interface 117. In an embodiment, the base stations 180a, 180b, 180c may implement MIMO technology. Thus, the base station 180a, for example, may use multiple antennas to

transmit wireless signals to, and receive wireless signals from, the WTRU 102a. The base stations 180a, 180b, 180c may also provide mobility management functions, such as handoff triggering, tunnel establishment, radio resource management, traffic classification, quality of service (QoS) policy enforcement, and the like. The ASN gateway 182 may serve as a traffic aggregation point and may be responsible for paging, caching of subscriber profiles, routing to the core network 109, and the like.

**[00320]** The air interface 117 between the WTRUs 102a, 102b, 102c and the RAN 105 may be defined as an R1 reference point that implements the IEEE 802.16 specification. In addition, each of the WTRUs 102a, 102b, and 102c may establish a logical interface (not shown) with the core network 109. The logical interface between the WTRUs 102a, 102b, 102c and the core network 109 may be defined as an R2 reference point, which may be used for authentication, authorization, IP host configuration management, and/or mobility management.

**[00321]** The communication link between each of the base stations 180a, 180b, and 180c may be defined as an R8 reference point that includes protocols for facilitating WTRU handovers and the transfer of data between base stations. The communication link between the base stations 180a, 180b, 180c and the ASN gateway 182 may be defined as an R6 reference point. The R6 reference point may include protocols for facilitating mobility management based on mobility events associated with each of the WTRUs 102a, 102b, 102c.

**[00322]** As shown in Figure 36E, the RAN 105 may be connected to the core network 109. The communication link between the RAN 105 and the core network 109 may be defined as an R3 reference point that includes protocols for facilitating data transfer and mobility management capabilities, for example. The core network 109 may include a mobile IP home agent (MIP-HA) 184, an authentication, authorization, accounting (AAA) server 186, and a gateway 188. While each of the foregoing elements are depicted as part of the core network 109, it will be appreciated that any one of these elements may be owned and/or operated by an entity other than the core network operator.

**[00323]** The MIP-HA may be responsible for IP address management, and may enable the WTRUs 102a, 102b, and 102c to roam between different ASNs and/or different core networks. The MIP-HA 184 may provide the WTRUs 102a, 102b, 102c with access to packet-switched networks, such as the Internet 110, to facilitate communications between the WTRUs 102a, 102b, 102c and IP-enabled devices. The AAA server 186 may be responsible for user authentication and for supporting user services. The gateway 188 may facilitate interworking with other networks. For example, the gateway 188 may provide the WTRUs 102a, 102b, 102c with access to circuit-switched networks, such as the PSTN 108, to facilitate communications

between the WTRUs 102a, 102b, 102c and traditional land-line communications devices. In addition, the gateway 188 may provide the WTRUs 102a, 102b, 102c with access to the networks 112, which may include other wired or wireless networks that are owned and/or operated by other service providers.

**[00324]** Although not shown in Figure 36E, it will be appreciated that the RAN 105 may be connected to other ASNs and the core network 109 may be connected to other core networks. The communication link between the RAN 105 the other ASNs may be defined as an R4 reference point, which may include protocols for coordinating the mobility of the WTRUs 102a, 102b, 102c between the RAN 105 and the other ASNs. The communication link between the core network 109 and the other core networks may be defined as an R5 reference, which may include protocols for facilitating interworking between home core networks and visited core networks.

**[00325]** The core network entities described herein and illustrated in Figures 36A, 36C, 36D, and 36E are identified by the names given to those entities in certain existing 3GPP specifications, but it is understood that in the future those entities and functionalities may be identified by other names and certain entities or functions may be combined in future specifications published by 3GPP, including future 3GPP NR specifications. Thus, the particular network entities and functionalities described and illustrated in Figures 36A, 36B, 36C, 36D, and 36E are provided by way of example only, and it is understood that the subject matter disclosed and claimed herein may be embodied or implemented in any similar communication system, whether presently defined or defined in the future.

**[00326]** Figure 36F is a block diagram of an exemplary computing system 90 in which one or more apparatuses of the communications networks illustrated in Figures 36A, 36C, 36D and 36E may be embodied, such as certain nodes or functional entities in the RAN 103/104/105, Core Network 106/107/109, PSTN 108, Internet 110, or Other Networks 112. Computing system 90 may comprise a computer or server and may be controlled primarily by computer readable instructions, which may be in the form of software, wherever, or by whatever means such software is stored or accessed. Such computer readable instructions may be executed within a processor 91, to cause computing system 90 to do work. The processor 91 may be a general purpose processor, a special purpose processor, a conventional processor, a digital signal processor (DSP), a plurality of microprocessors, one or more microprocessors in association with a DSP core, a controller, a microcontroller, Application Specific Integrated Circuits (ASICs), Field Programmable Gate Array (FPGAs) circuits, any other type of integrated circuit (IC), a state machine, and the like. The processor 91 may perform signal coding, data processing,

power control, input/output processing, and/or any other functionality that enables the computing system 90 to operate in a communications network. Coprocessor 81 is an optional processor, distinct from main processor 91, that may perform additional functions or assist processor 91. Processor 91 and/or coprocessor 81 may receive, generate, and process data related to the methods and apparatuses disclosed herein.

**[00327]** In operation, processor 91 fetches, decodes, and executes instructions, and transfers information to and from other resources via the computing system's main data-transfer path, system bus 80. Such a system bus connects the components in computing system 90 and defines the medium for data exchange. System bus 80 typically includes data lines for sending data, address lines for sending addresses, and control lines for sending interrupts and for operating the system bus. An example of such a system bus 80 is the PCI (Peripheral Component Interconnect) bus.

**[00328]** Memories coupled to system bus 80 include random access memory (RAM) 82 and read only memory (ROM) 93. Such memories include circuitry that allows information to be stored and retrieved. ROMs 93 generally contain stored data that cannot easily be modified. Data stored in RAM 82 can be read or changed by processor 91 or other hardware devices. Access to RAM 82 and/or ROM 93 may be controlled by memory controller 92. Memory controller 92 may provide an address translation function that translates virtual addresses into physical addresses as instructions are executed. Memory controller 92 may also provide a memory protection function that isolates processes within the system and isolates system processes from user processes. Thus, a program running in a first mode can access only memory mapped by its own process virtual address space; it cannot access memory within another process's virtual address space unless memory sharing between the processes has been set up.

**[00329]** In addition, computing system 90 may contain peripherals controller 83 responsible for communicating instructions from processor 91 to peripherals, such as printer 94, keyboard 84, mouse 95, and disk drive 85.

**[00330]** Display 86, which is controlled by display controller 96, is used to display visual output generated by computing system 90. Such visual output may include text, graphics, animated graphics, and video. The visual output may be provided in the form of a graphical user interface (GUI). Display 86 may be implemented with a CRT-based video display, an LCD-based flat-panel display, gas plasma-based flat-panel display, or a touch-panel. Display controller 96 includes electronic components required to generate a video signal that is sent to display 86.

**[00331]** Further, computing system 90 may contain communication circuitry, such as for example a network adapter 97, that may be used to connect computing system 90 to an external communications network, such as the RAN 103/104/105, Core Network 106/107/109, PSTN 108, Internet 110, or Other Networks 112 of FIGs. 36A, 36B, 36C, 36D, and 36E, to enable the computing system 90 to communicate with other nodes or functional entities of those networks. The communication circuitry, alone or in combination with the processor 91, may be used to perform the transmitting and receiving steps of certain apparatuses, nodes, or functional entities described herein.

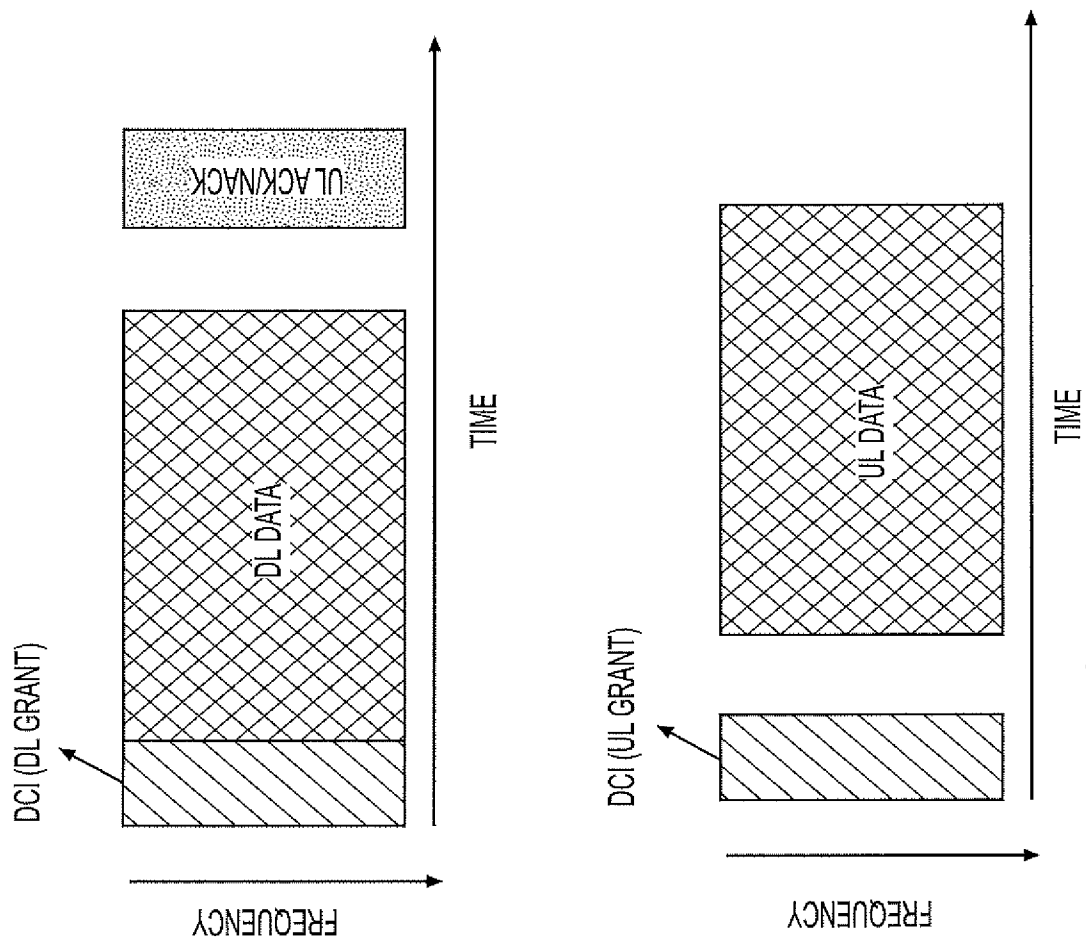
**[00332]** It is understood that any or all of the apparatuses, systems, methods and processes described herein may be embodied in the form of computer executable instructions (e.g., program code) stored on a computer-readable storage medium which instructions, when executed by a processor, such as processors 118 or 91, cause the processor to perform and/or implement the systems, methods and processes described herein. Specifically, any of the steps, operations or functions described herein may be implemented in the form of such computer executable instructions, executing on the processor of an apparatus or computing system configured for wireless and/or wired network communications. Computer readable storage media include volatile and nonvolatile, removable and non-removable media implemented in any non-transitory (e.g., tangible or physical) method or technology for storage of information, but such computer readable storage media do not include signals. Computer readable storage media include, but are not limited to, RAM, ROM, EEPROM, flash memory or other memory technology, CD-ROM, digital versatile disks (DVD) or other optical disk storage, magnetic cassettes, magnetic tape, magnetic disk storage or other magnetic storage devices, or any other tangible or physical medium which can be used to store the desired information and which can be accessed by a computing system.

**WHAT IS CLAIMED:**

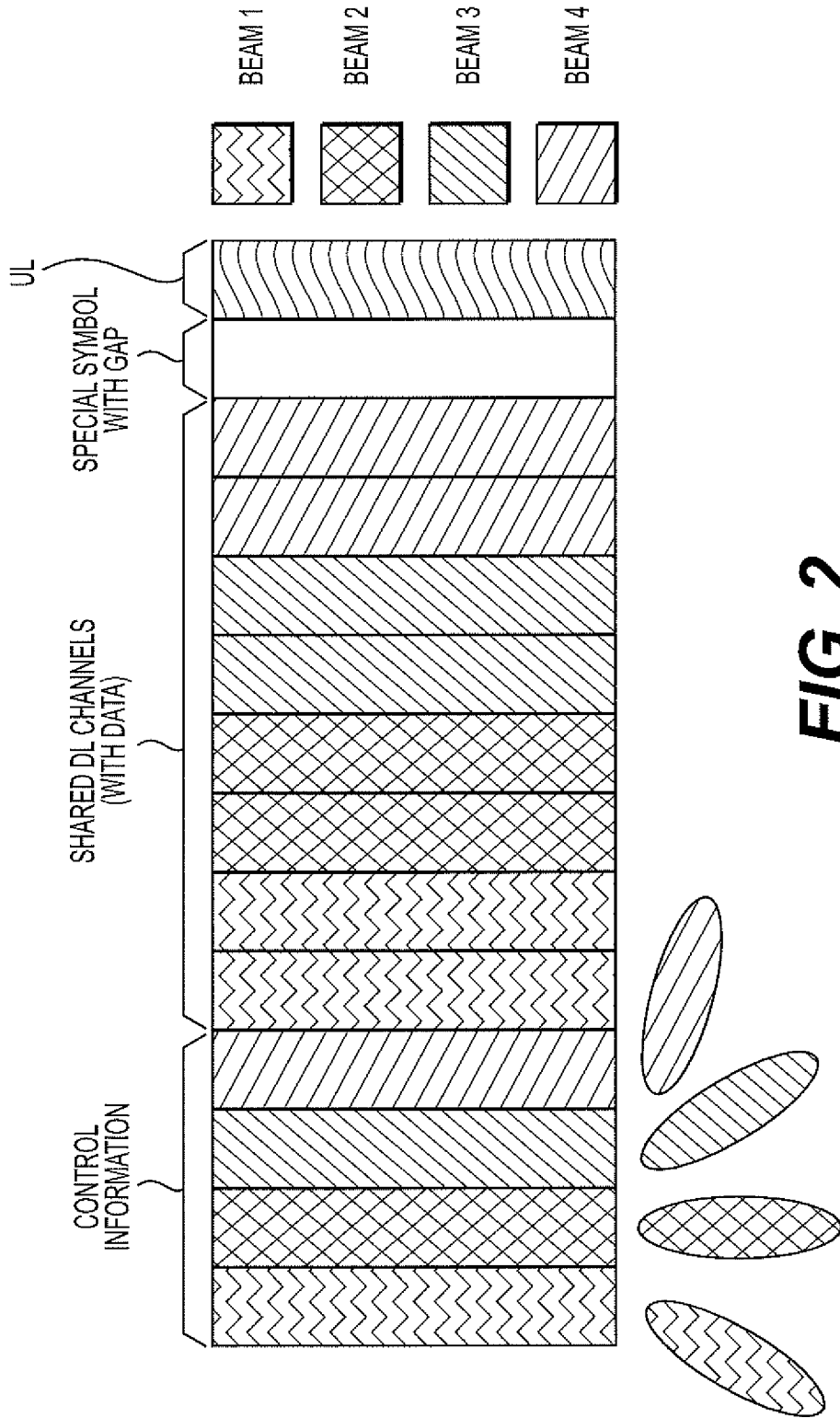
1. A frame structure in new radio comprising:  
a self-contained transmission time interval, the transmission interval including  
a control information region including plural beams, and  
a downlink transmission channel region including plural beams, wherein  
downlink control information is swept through the time interval, and  
then, an uplink or downlink grant resource is swept through the time interval.
2. The frame structure of claim 1, wherein the downlink control information is transmitted on a subset of the plural beams in the control information region.
3. The frame structure of claim 2, wherein each of the plural beams carries plural symbols with downlink control information and data.
4. The frame structure of claim 1, wherein the downlink control information includes control reference signals and beam reference signals.
5. The frame structure of claim 4, wherein the control reference signals span both the control information region and downlink transmission channel region.
6. The frame structure of claim 1, wherein the downlink control information includes a fixed duration for each of the plural beams.
7. The frame structure of claim 6, wherein  
one of the plural beams operates at 60 KHz and another beam operates at 15 KHz, and  
the 60 KHz beam includes plural symbols based upon center frequency, bandwidth and  
number of supported beams.
8. The frame structure of claim 1, wherein the downlink control information includes channel state information received from user equipment selected from rank indication, precoder matrix indication, channel-quality indication and combination thereof.

9. The frame structure of claim 1, wherein the downlink control information includes control demodulation reference signals.
10. A frame structure operating in new radio comprising:
  - a transmission bandwidth including
    - a timeslot for control and data signaling, the timeslot having a first numerology and a second numerology, the first numerology supporting a first subcarrier spacing and the second numerology supporting a second subcarrier spacing; and
    - a fixed time slot including a beam having a sounding reference signal.
11. The frame structure of claim 10, wherein the first subcarrier spacing is different from the second subcarrier spacing.
12. The frame structure of claim 11, wherein the first and second subcarrier spacing is 15 KHz or 60 KHz.
13. The frame structure of claim 10, wherein the fixed time slot includes plural beams.
14. The frame structure of claim 13, wherein each of the plural beams in the fixed time slot has the same numerology.
15. A method for configuring user equipment comprising:
  - configuring a set of 'K' channel state information interference channel measurement (CSI-ICM) and channel state interference reference signal (CSI-RS) resources for a group of user equipment;
  - indicating, for one of the user equipment in the group, at least 'N' of the 'K' CSI-ICM resources via dynamic signaling based on interference;
  - transmitting downlink control information including the CSI-ICM to the group; a CSI-RS (and CSI-interference channel measurement) protocol to the user equipment;
  - receiving, from the UE in the group, feedback of the CSI and CSI-ICM for the interference channel;
  - scheduling a MU-MIMO transmission for the user equipment; and
  - determining a cancelation of interference transmitted from one user equipment to other co-scheduled UEs.

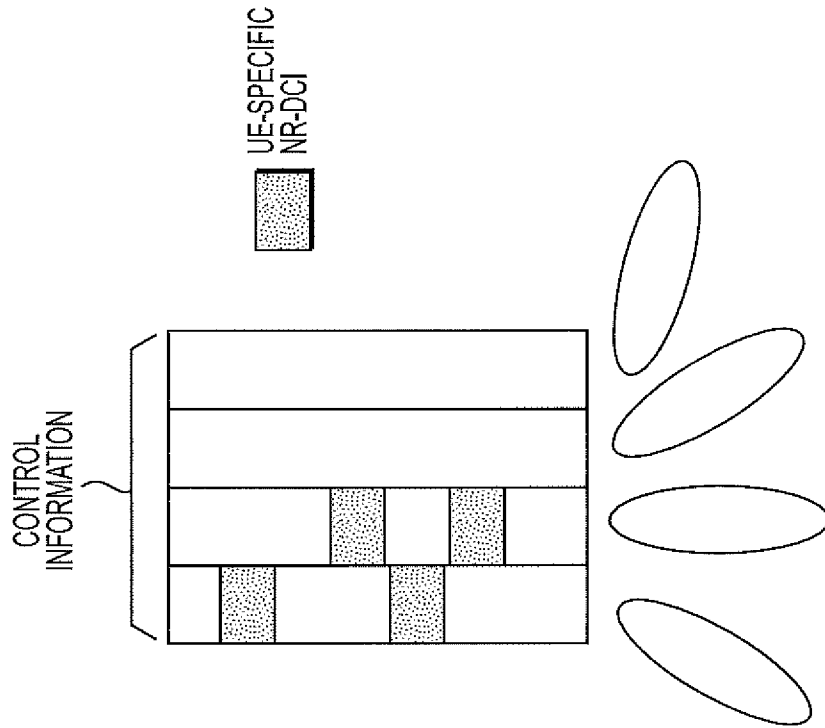
16. The method of claim 15, wherein  
the dynamic signaling is via downlink control information (DCI), and  
'N' is dependent upon the number of interference sources.
  
17. The method of claim 15, wherein the CSI-ICM is based upon information selected from Group ID, CSI-ICM resources indication, CSI-ICM feedback indication, CSI-RS resource indication, CSI-IM resource indication, CSI feedback configuration, index information of the user equipment in the group, uplink resources of user equipment and combinations thereof.
  
18. The method of claim 15, wherein feedback includes:  
implicit feedback based upon one or more of a channel quality indication, precoder matrix indication, and rank indication, and  
explicit feedback based upon one or more of an exact interference measurement, eigenvectors of the interference channel according to the largest eigenvalues, and covariance matrix of the interference channel.
  
19. The method of claim 15, wherein the MU-MIMO transmission includes information selected from a resource allocation, modulation, coding scheme, HARQ process number, antenna port indices, precoding matrix information; decoding matrix information and combinations thereof.
  
20. The method of claim 15, wherein the apparatus is a new radio node or a transmission and reception point.



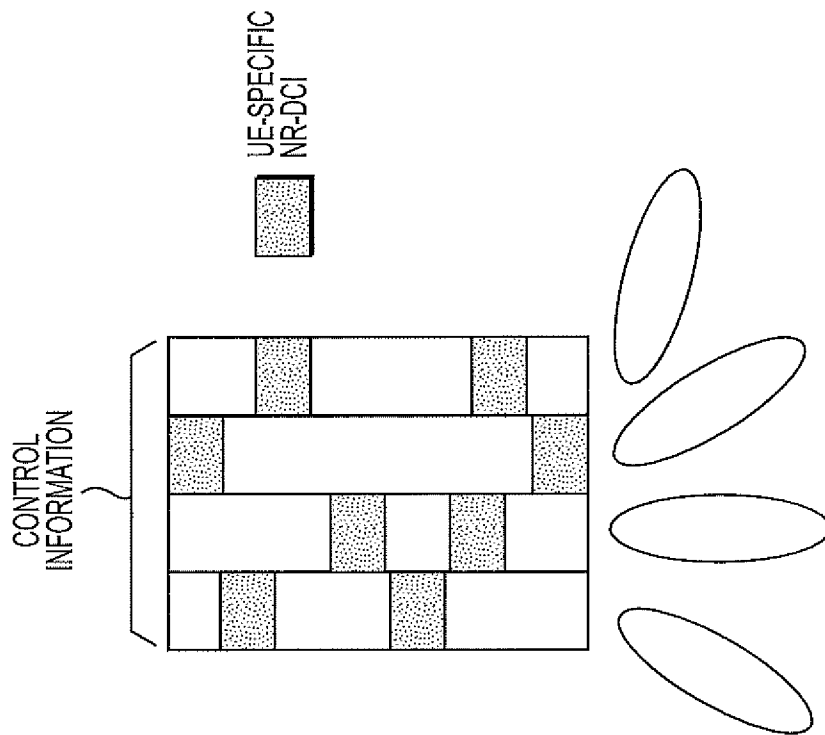
**FIG. 1**



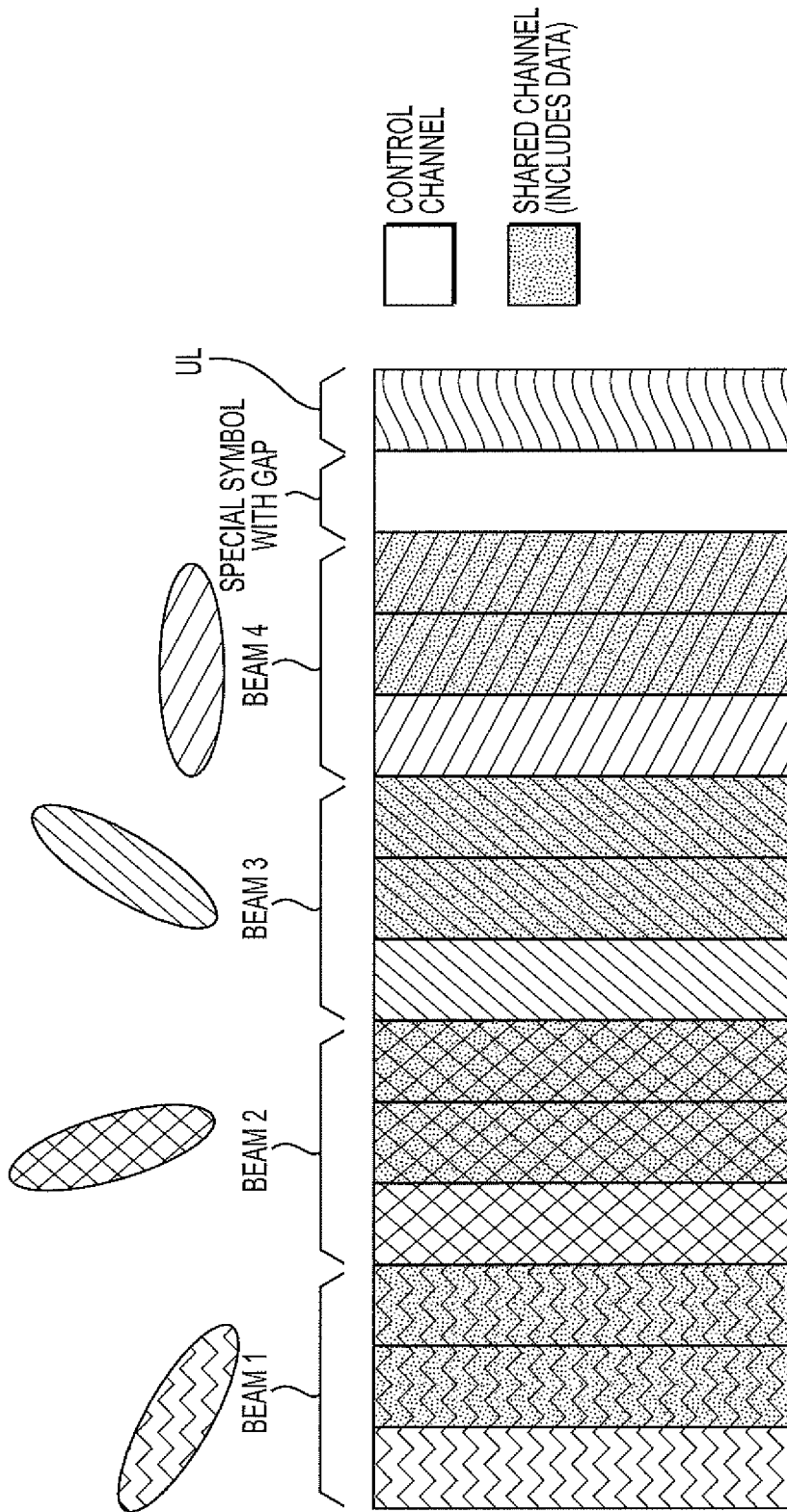
**FIG. 2**



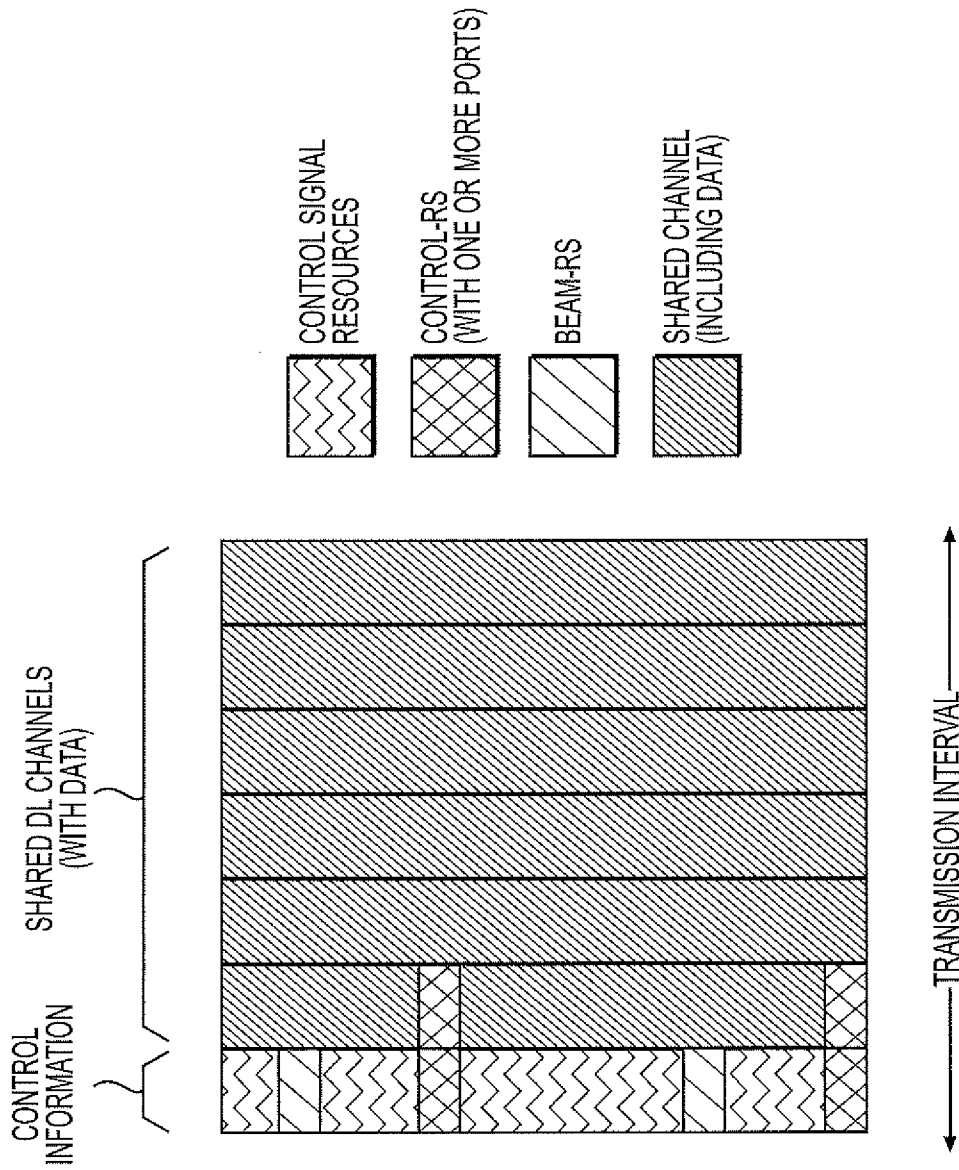
**FIG. 3B**



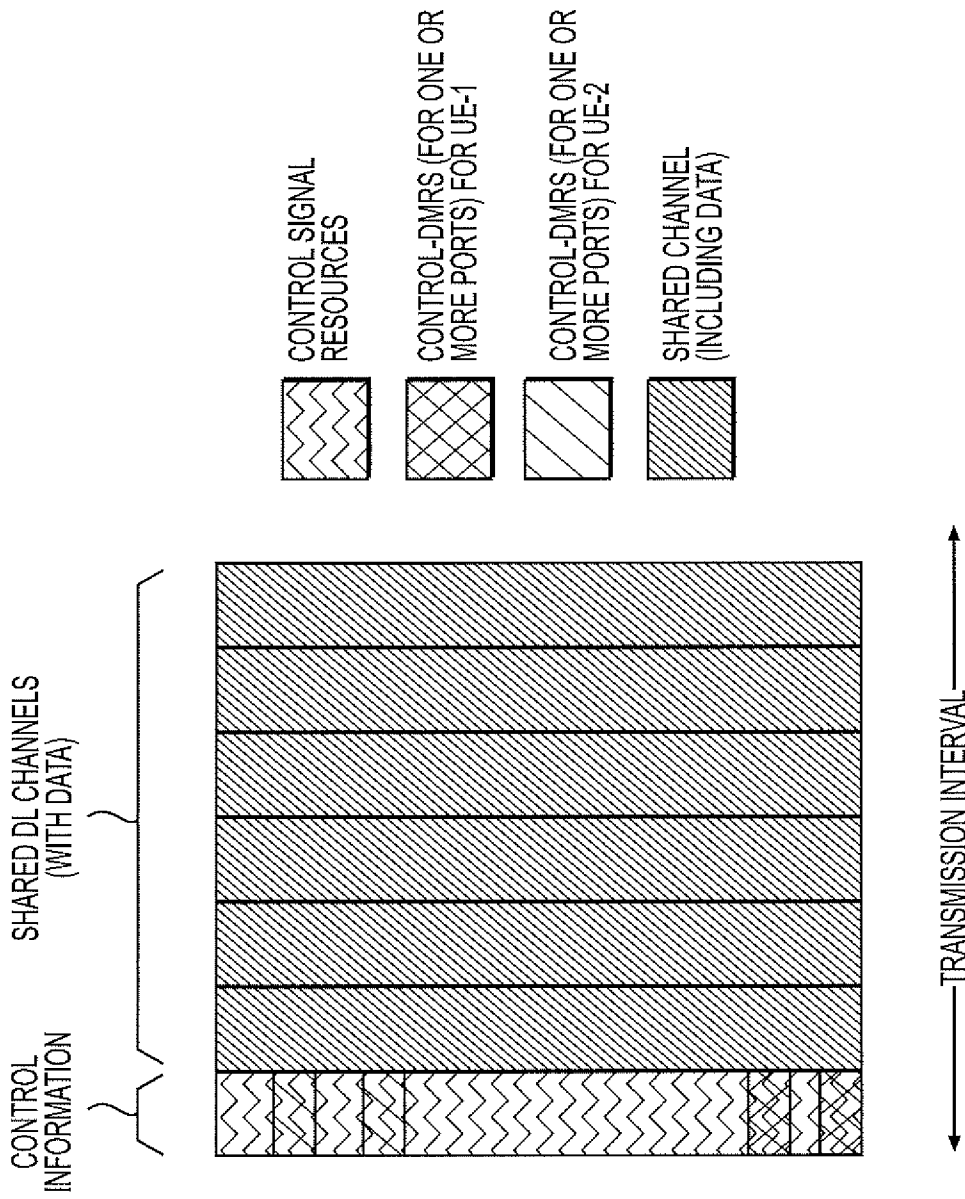
**FIG. 3A**



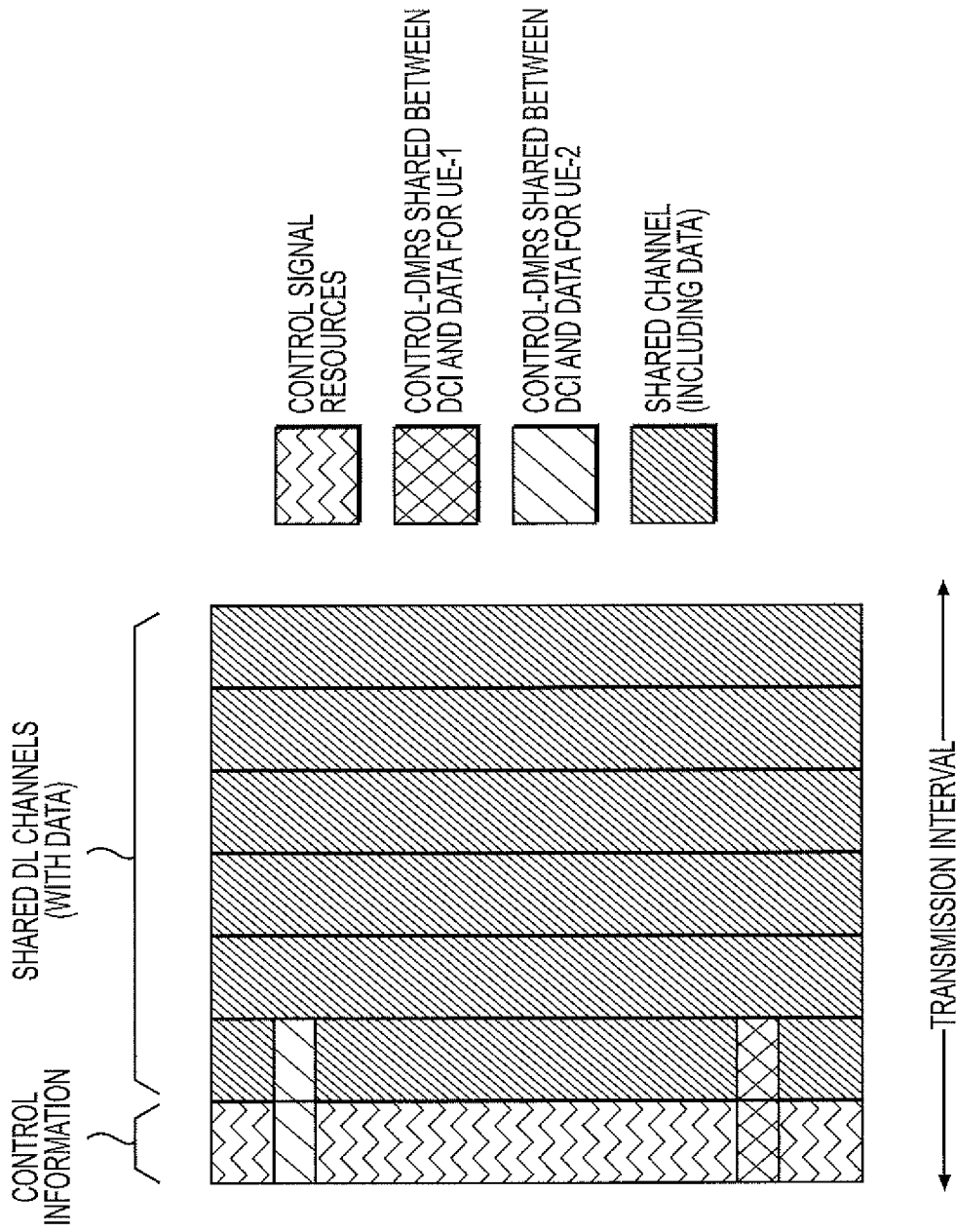
**FIG. 4**



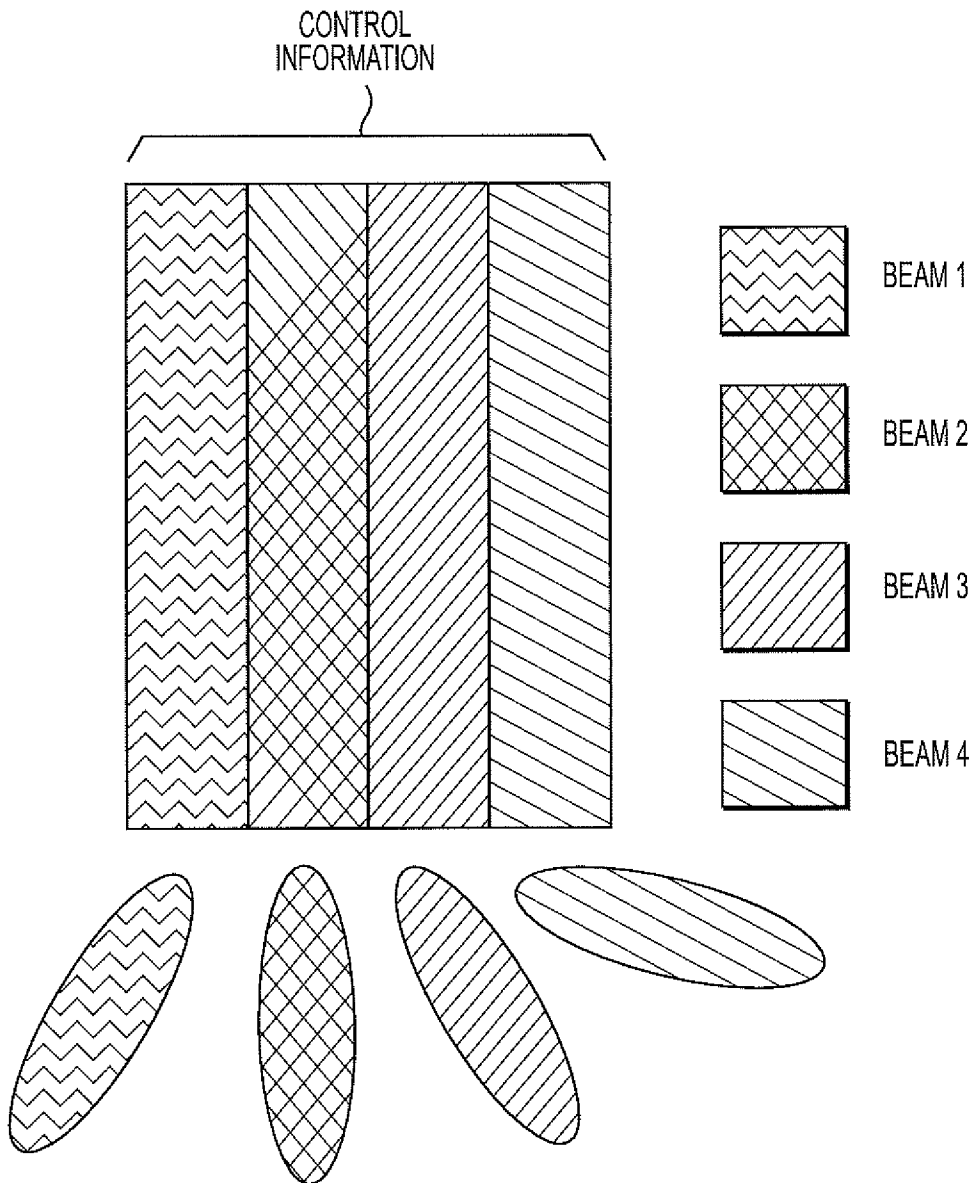
**FIG. 5**



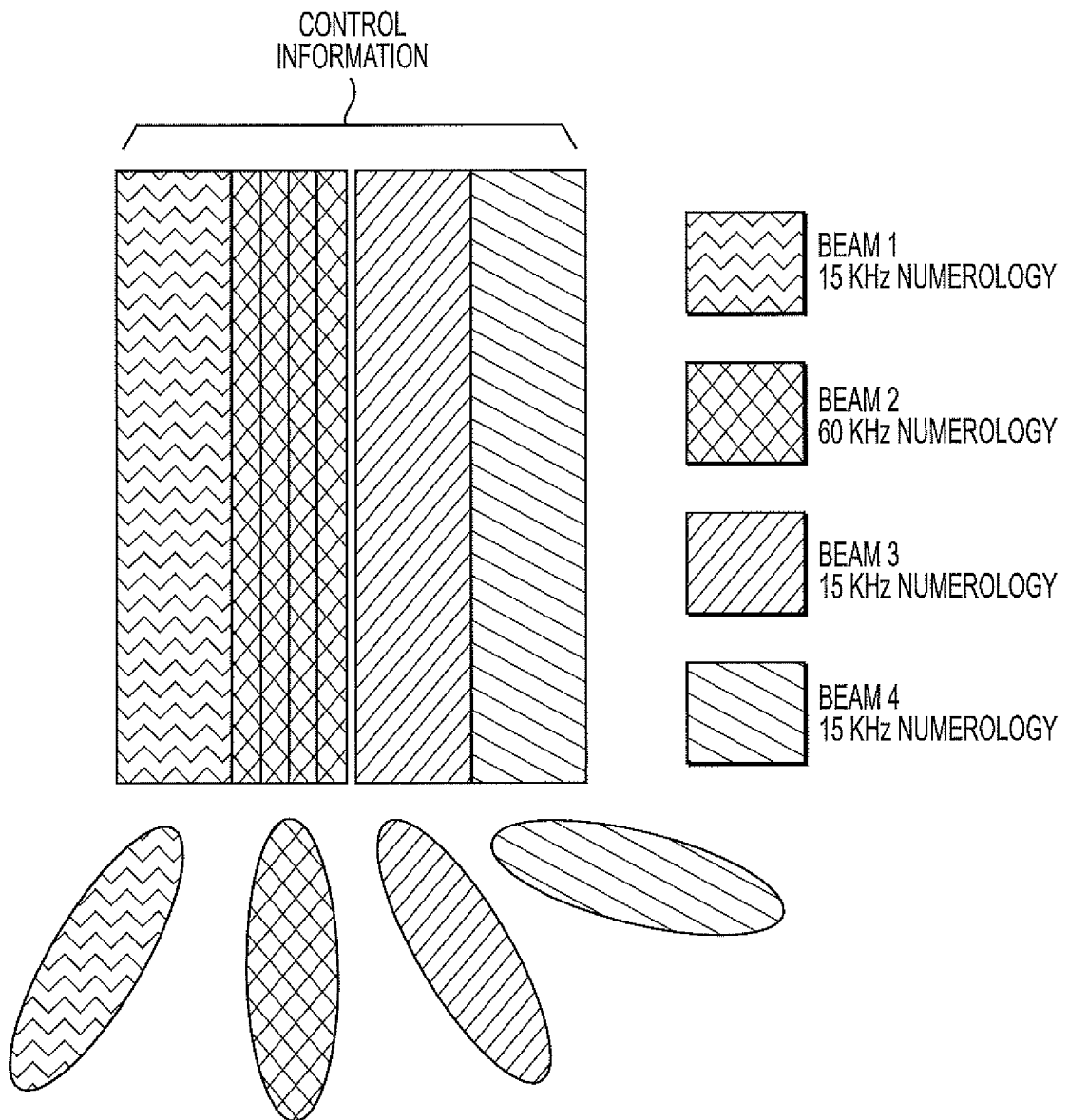
**FIG. 6**



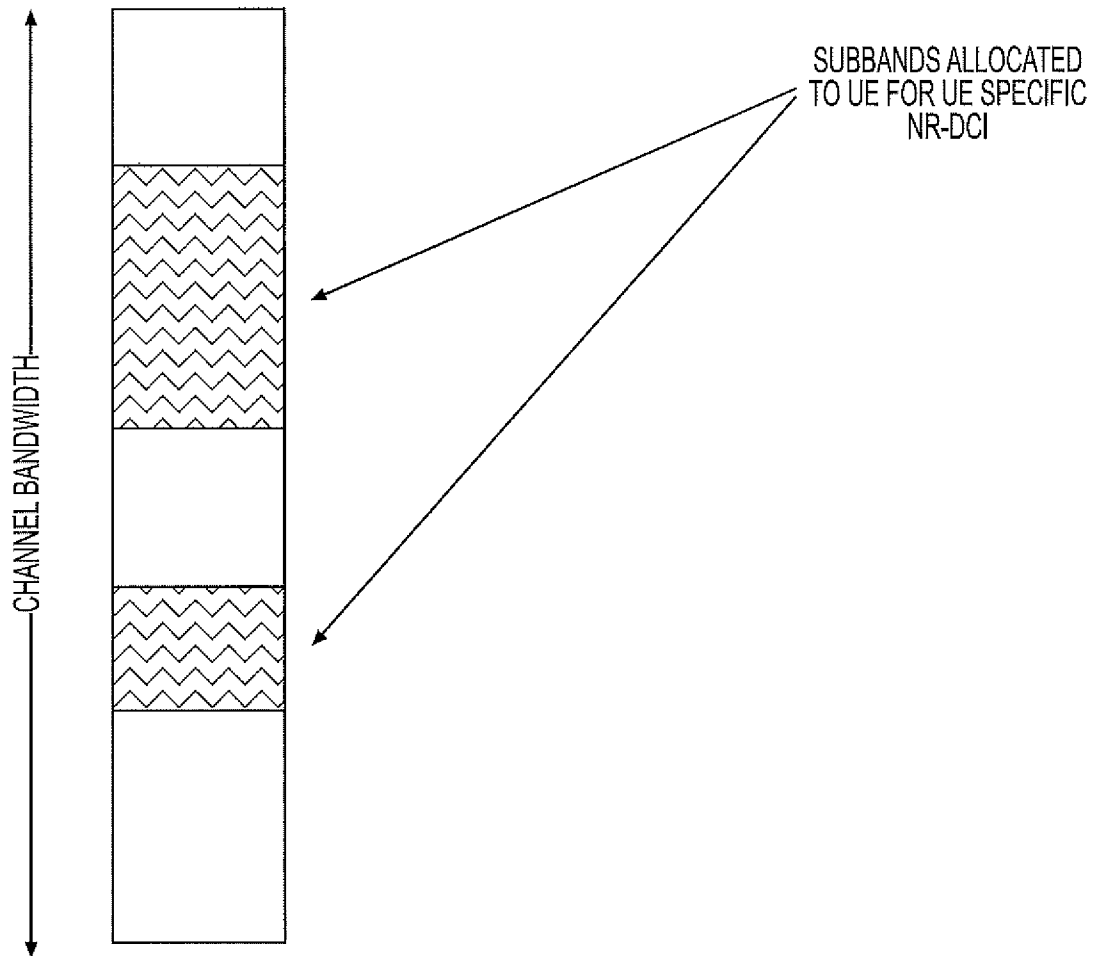
**FIG. 7**



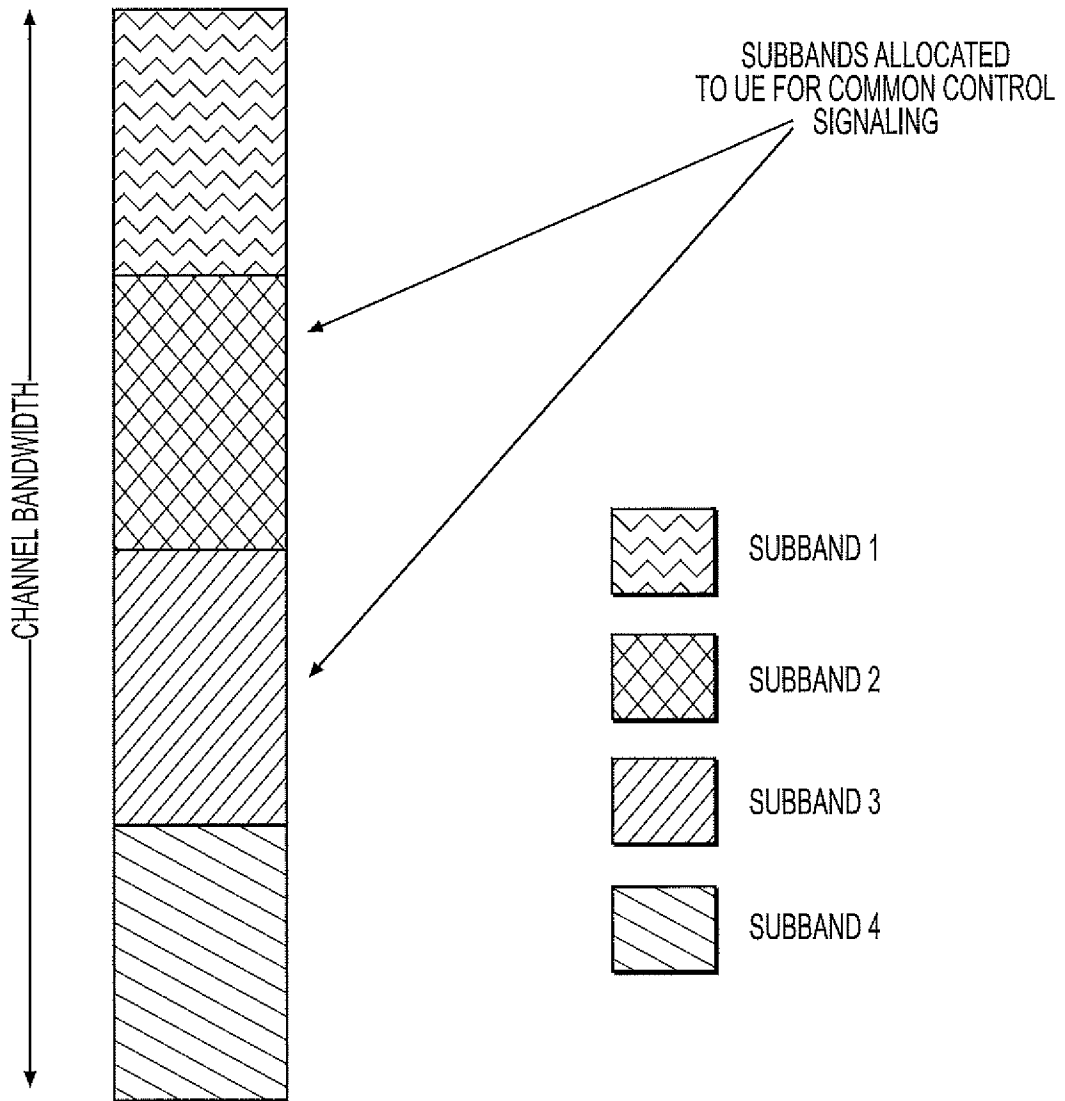
**FIG. 8**



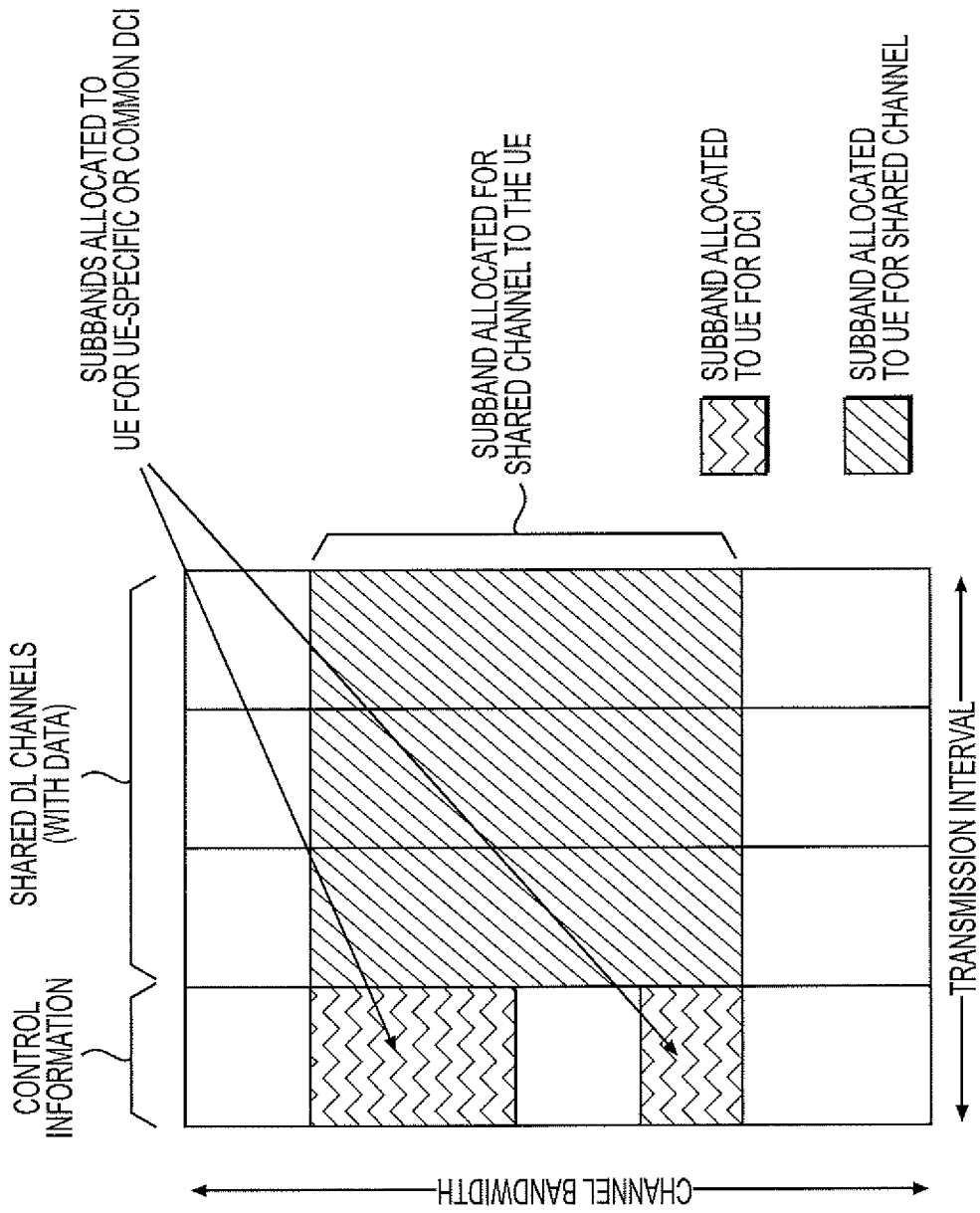
**FIG. 9**



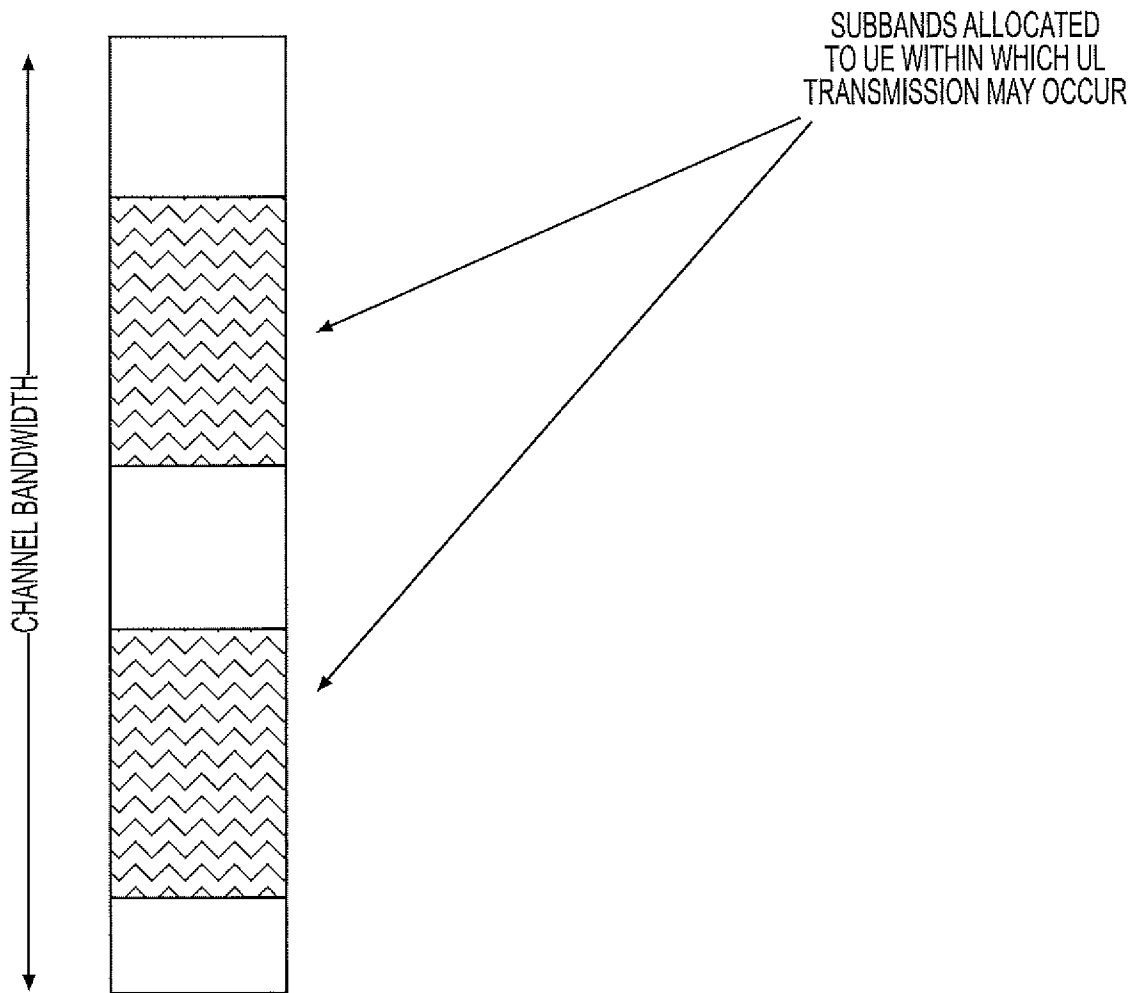
**FIG. 10**



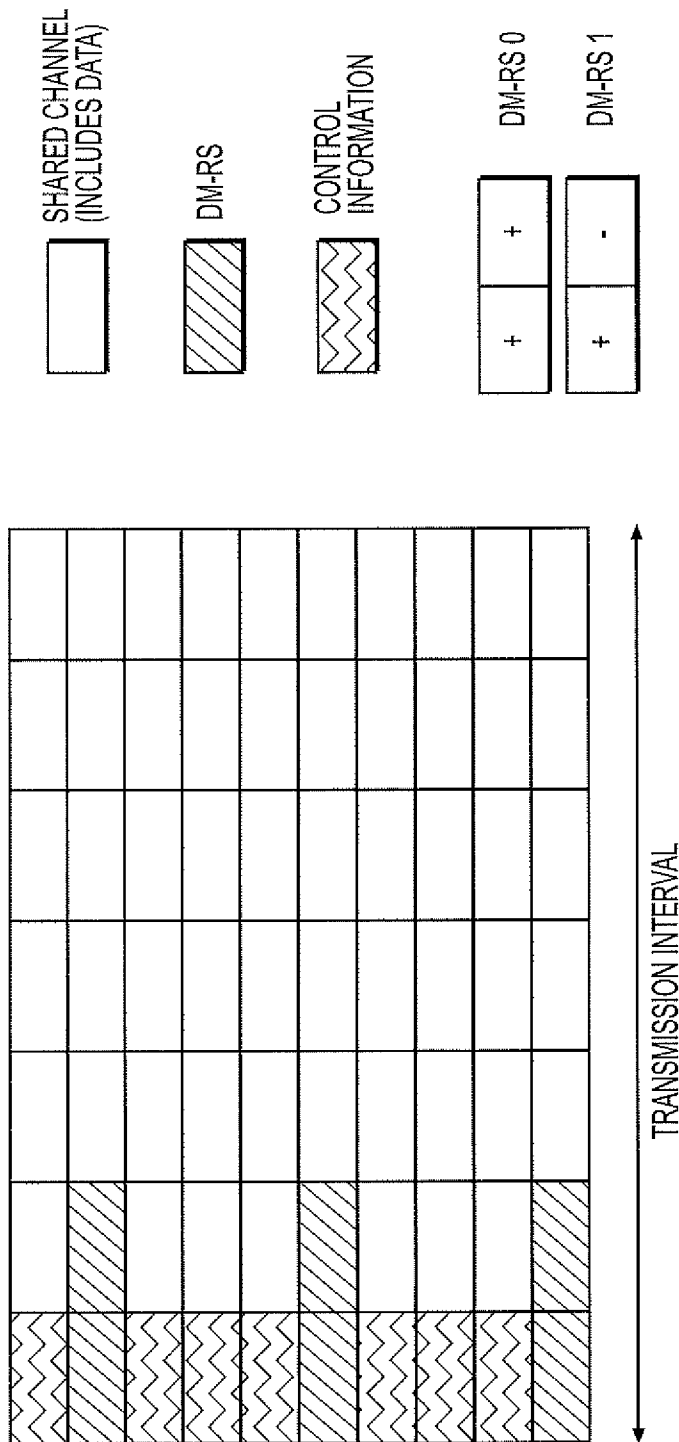
**FIG. 11**



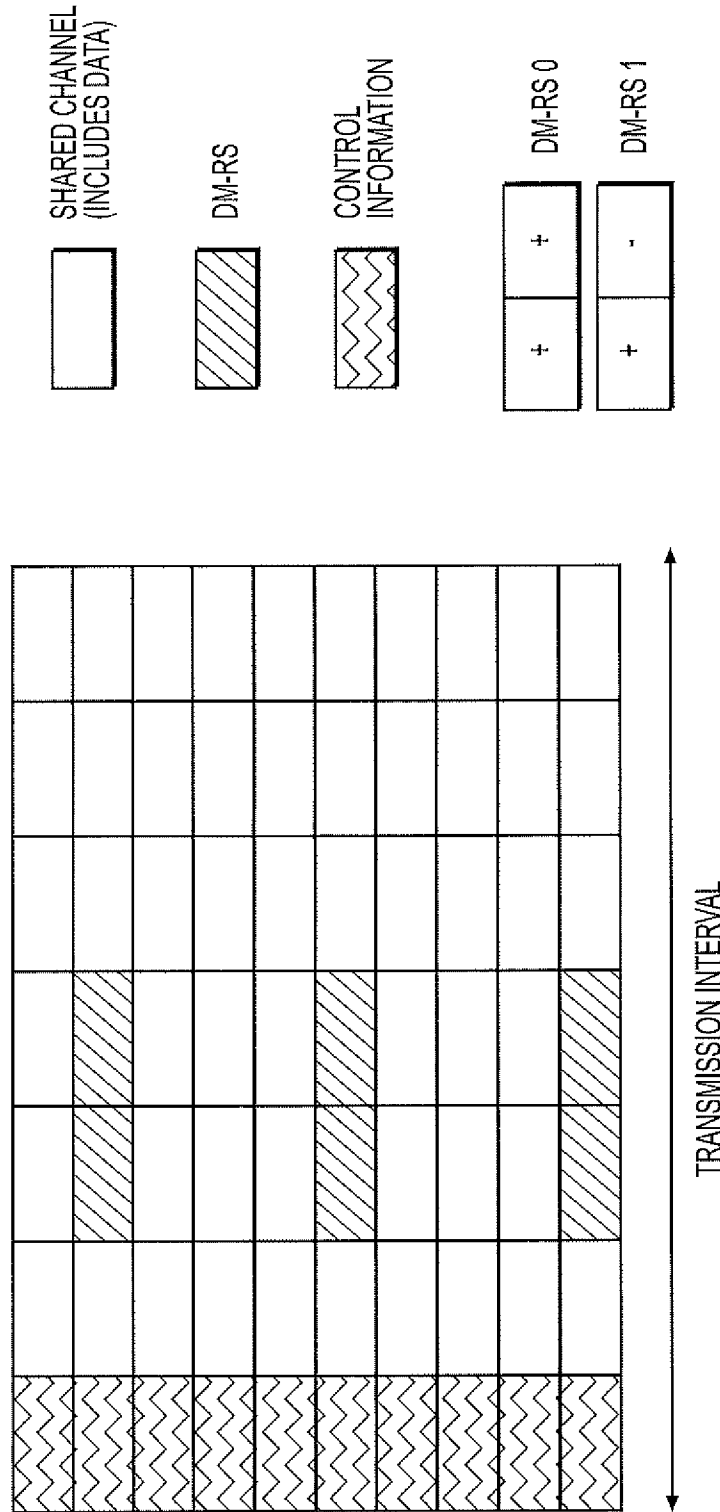
**FIG. 12**



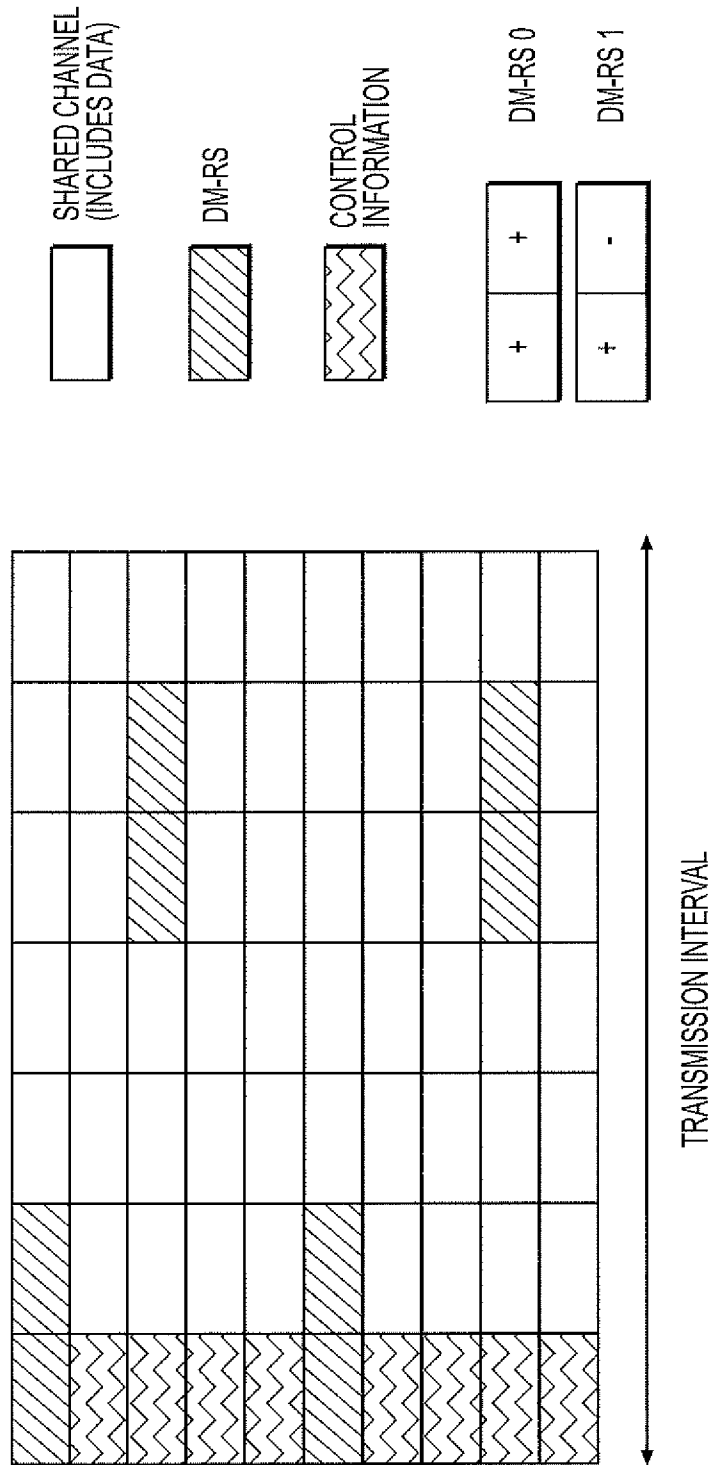
**FIG. 13**



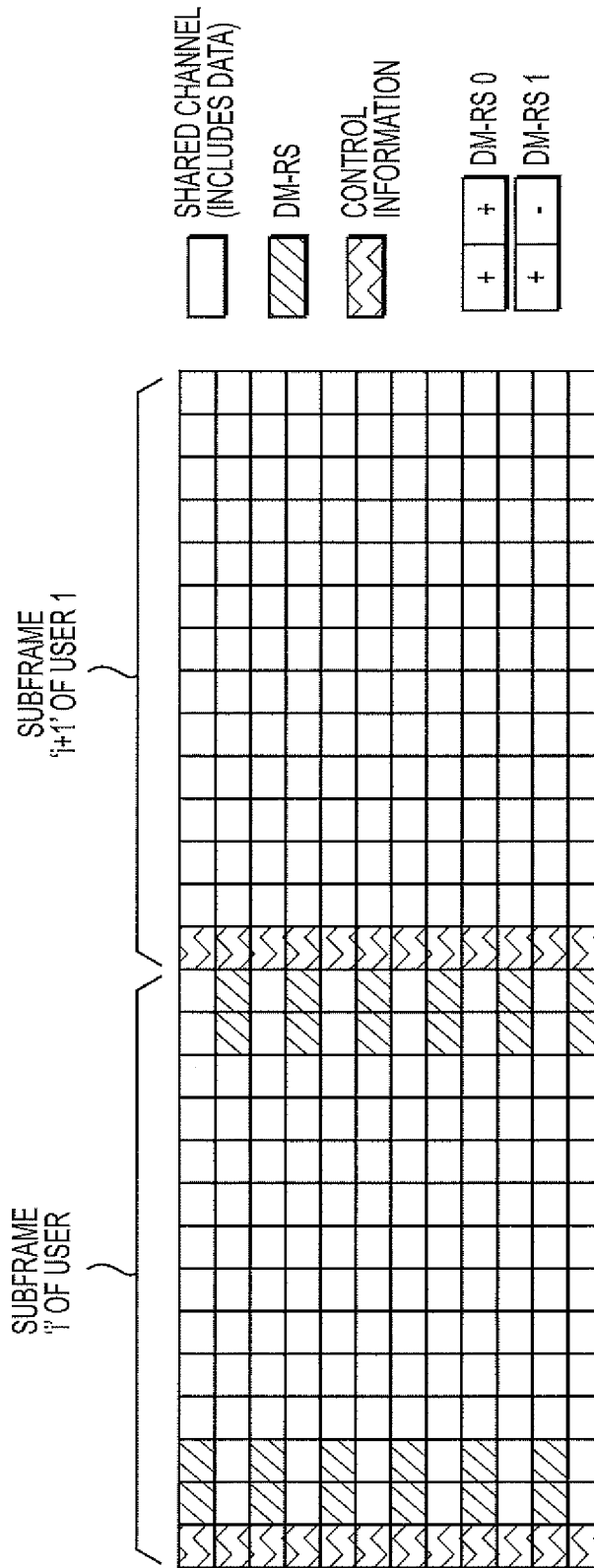
**FIG. 14**



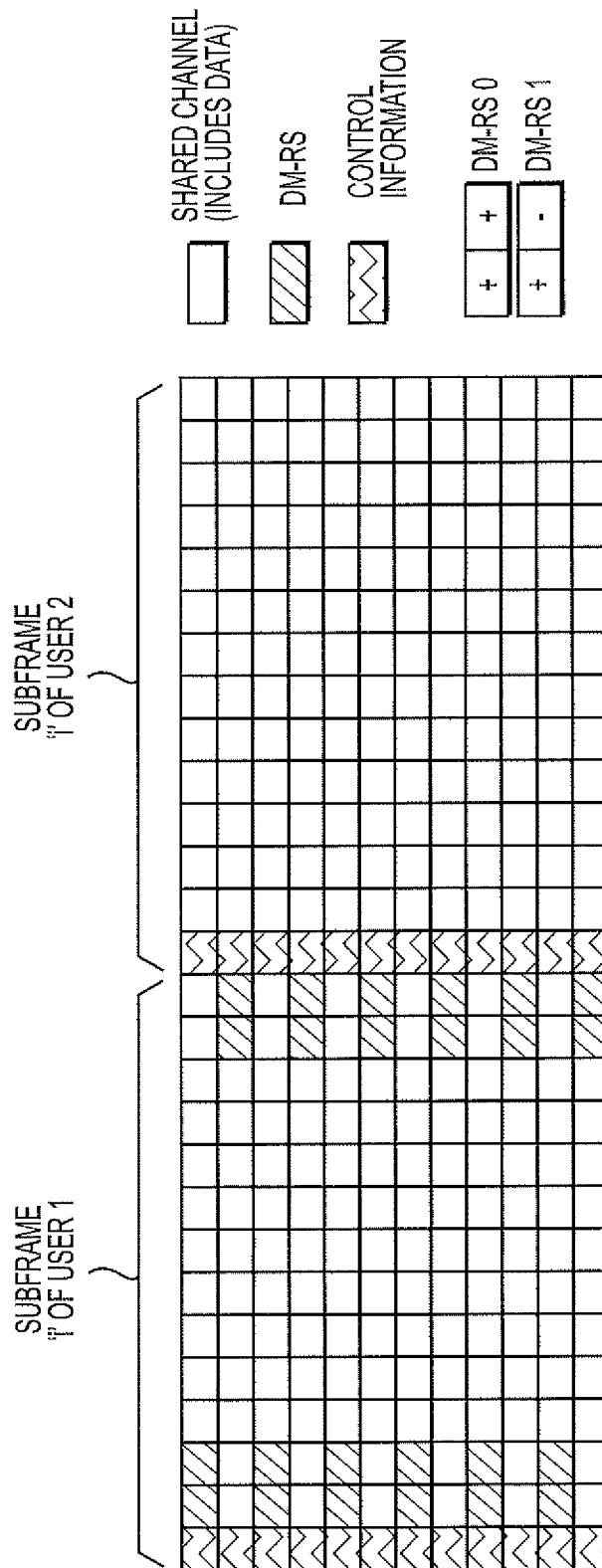
**FIG. 15**



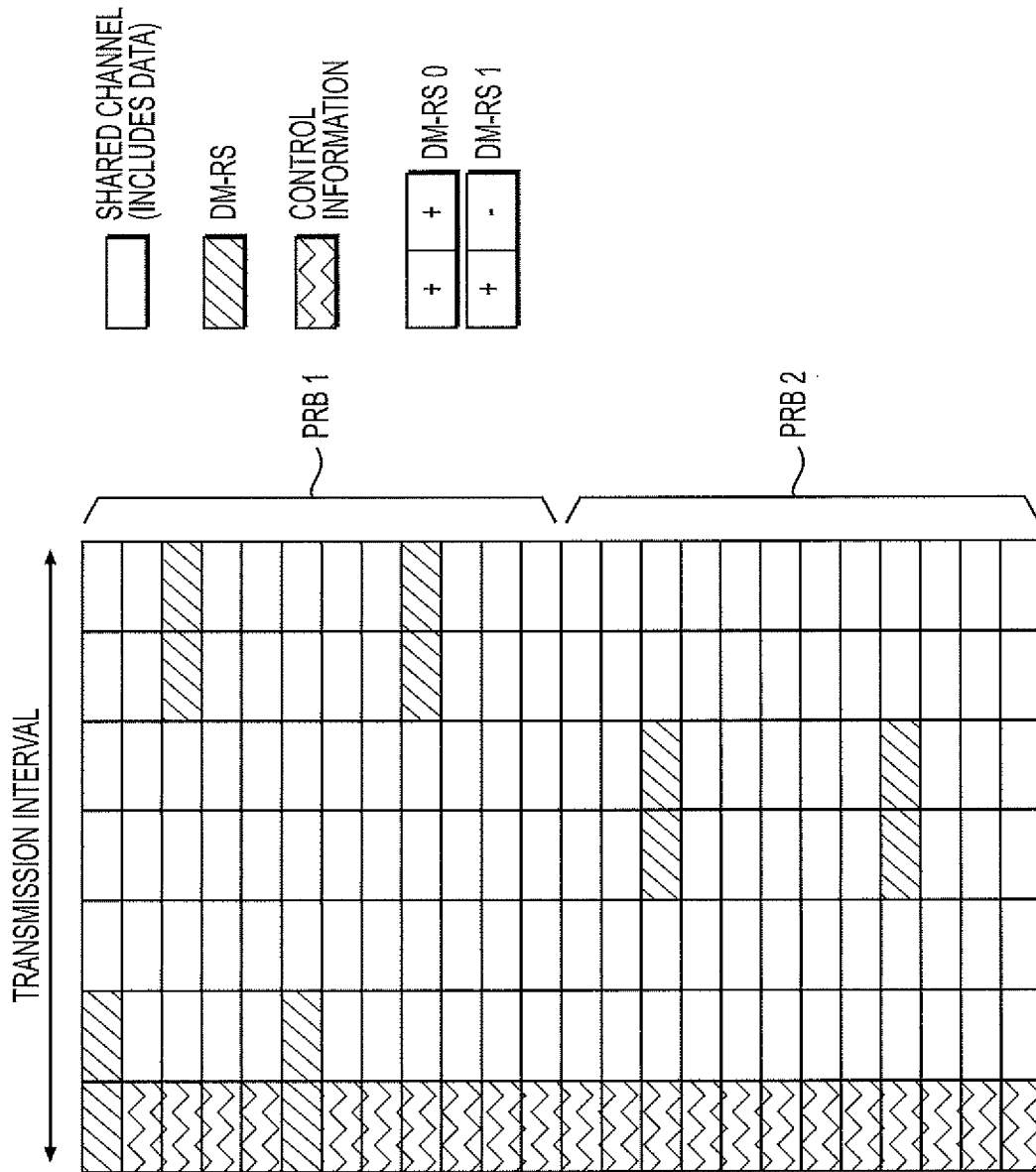
**FIG. 16**



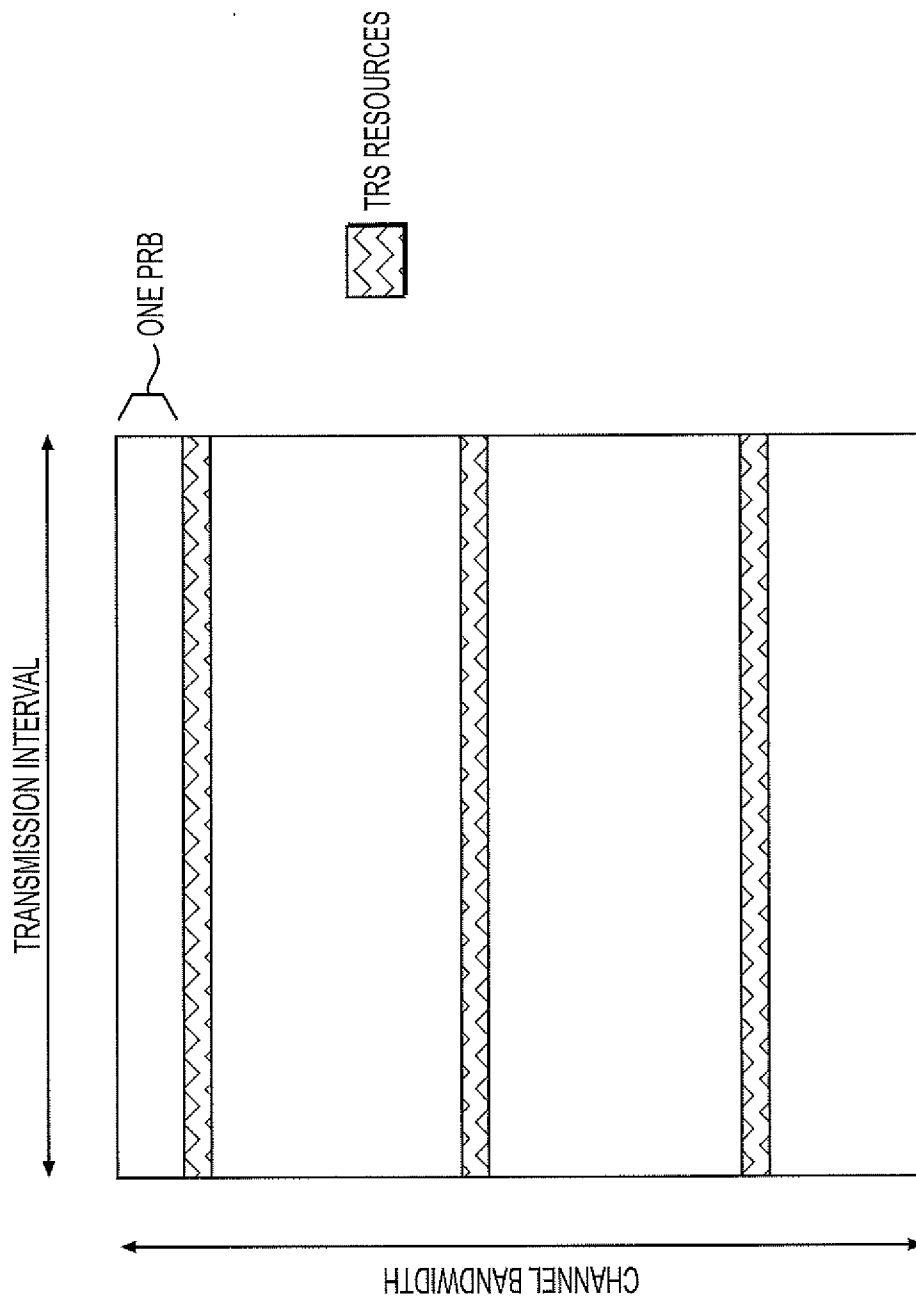
**FIG. 17A**



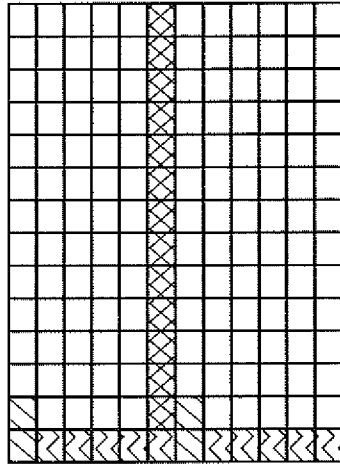
**FIG. 17B**



**FIG. 18**

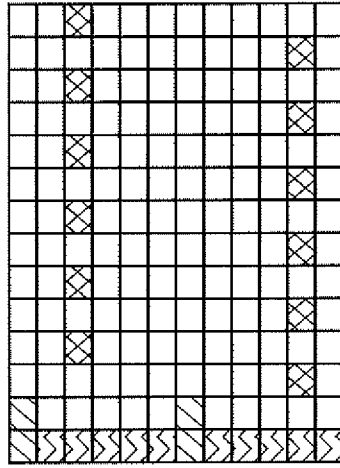


**FIG. 19**



**FIG. 20A**

- SHARED CHANNEL (INCLUDING DATA)
- DMRS
- CONTROL INFORMATION
- TRACKING RS

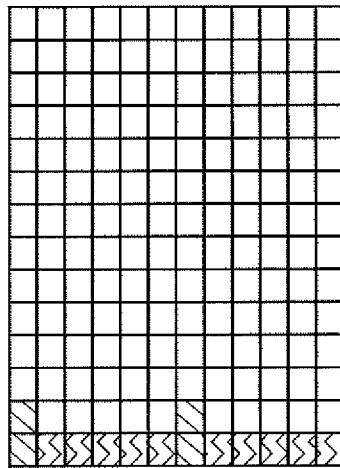


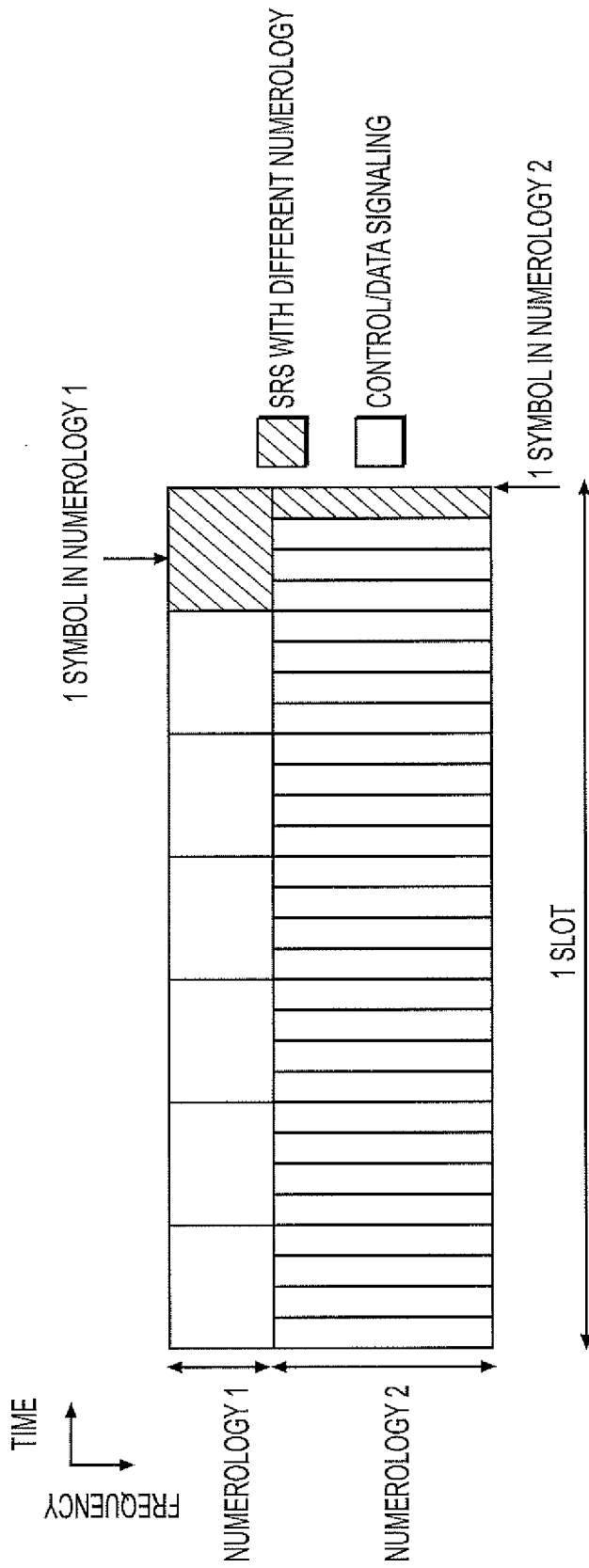
**FIG. 20B**

- SHARED CHANNEL (INCLUDING DATA)
- DMRS
- CONTROL INFORMATION
- TRACKING RS

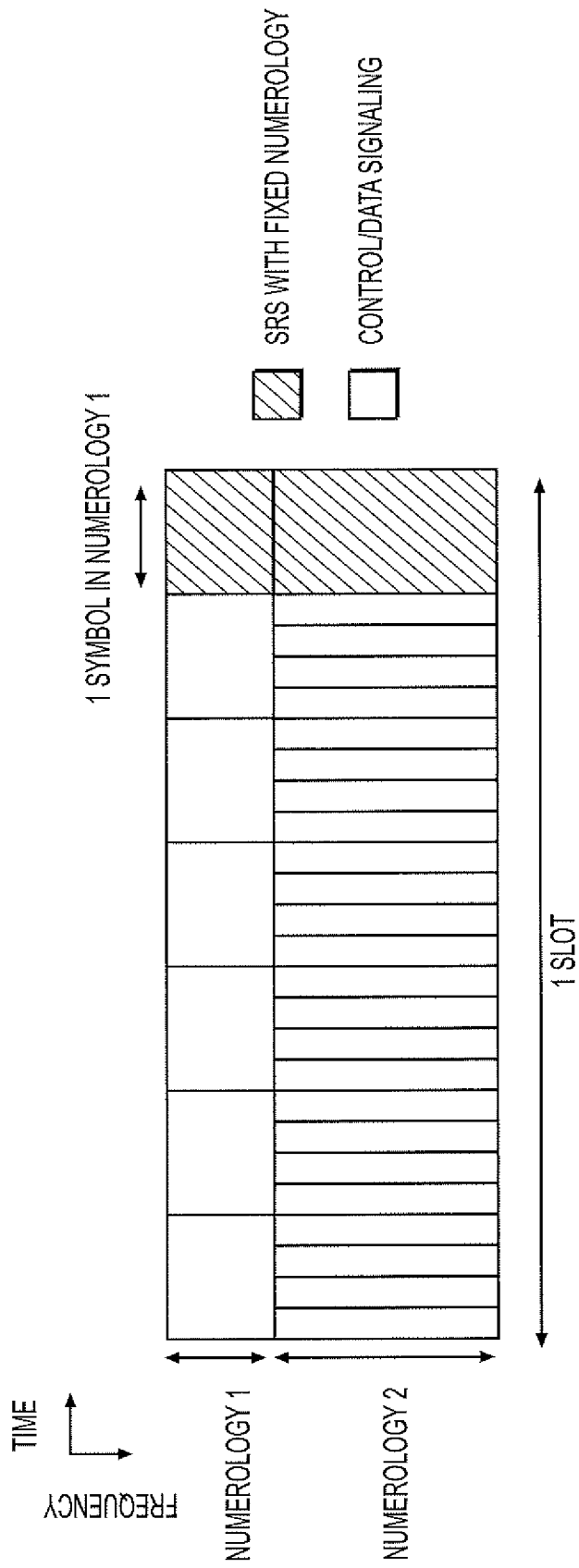
- SHARED CHANNEL (INCLUDING DATA)
- DMRS
- CONTROL INFORMATION
- TRACKING RS

**FIG. 20C**

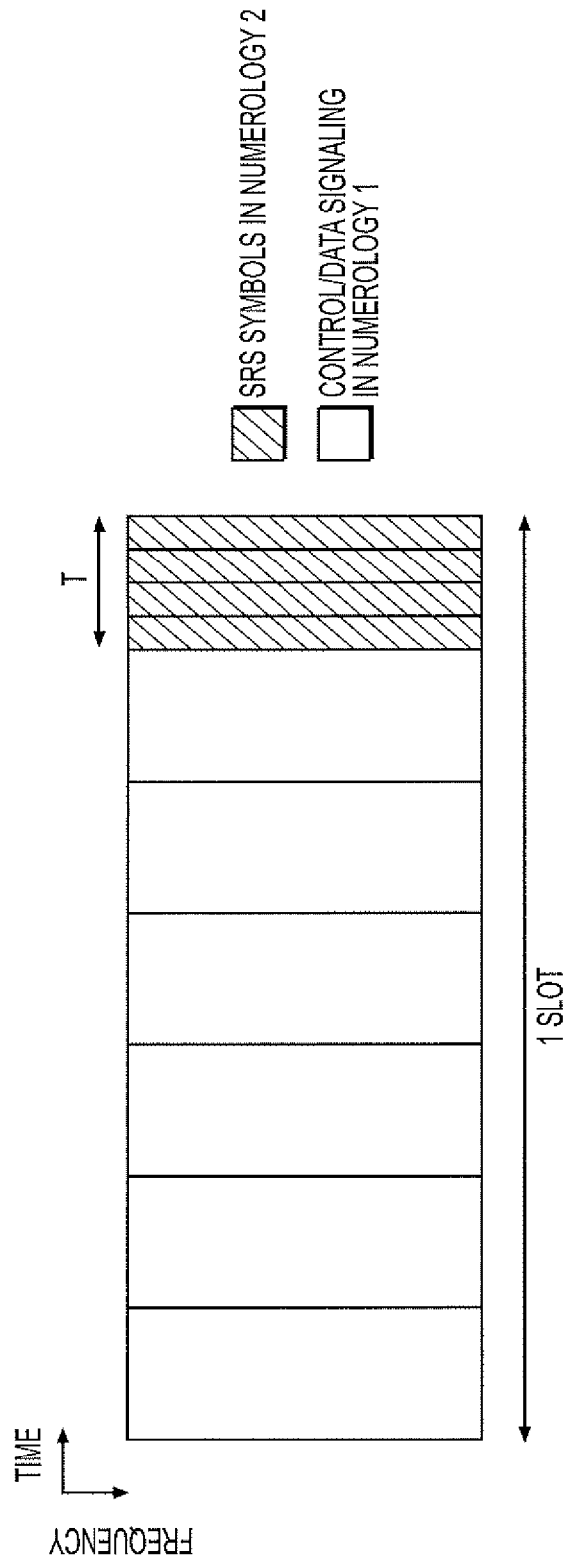




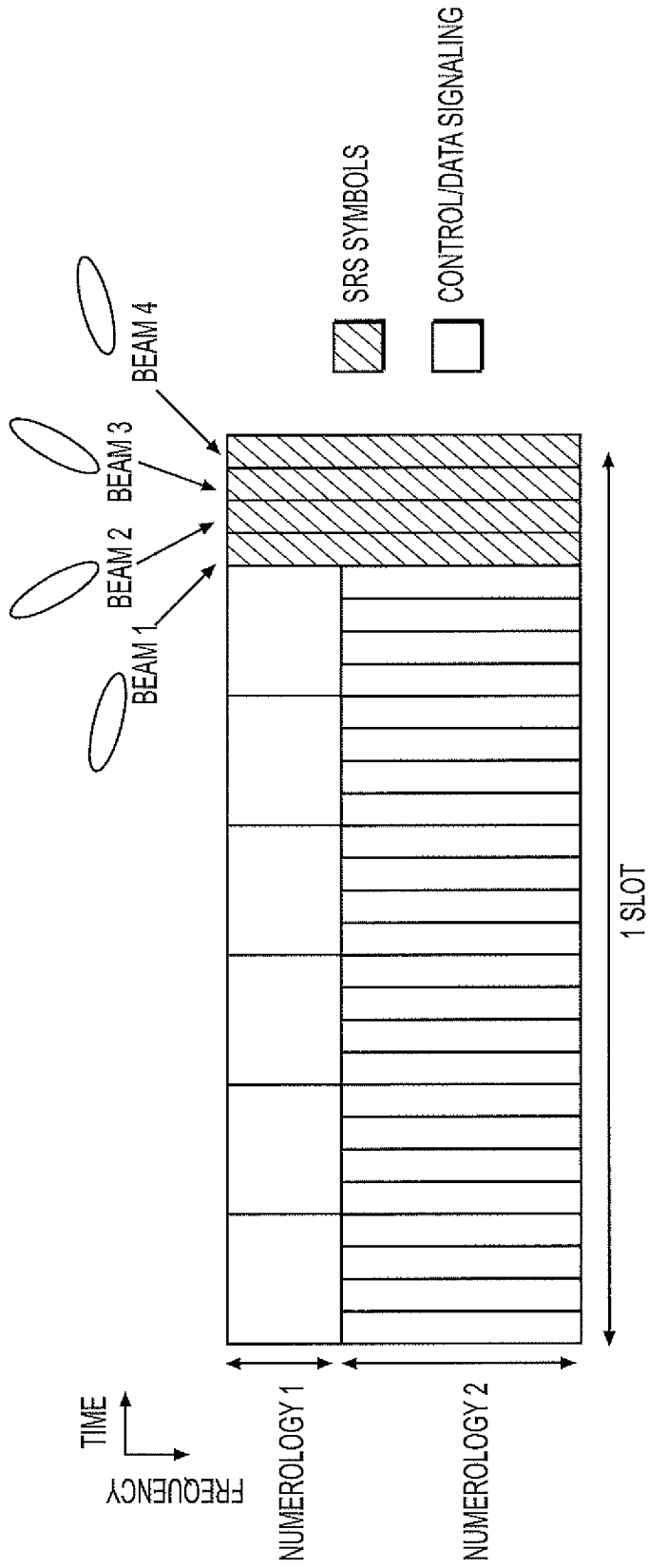
**FIG. 21**



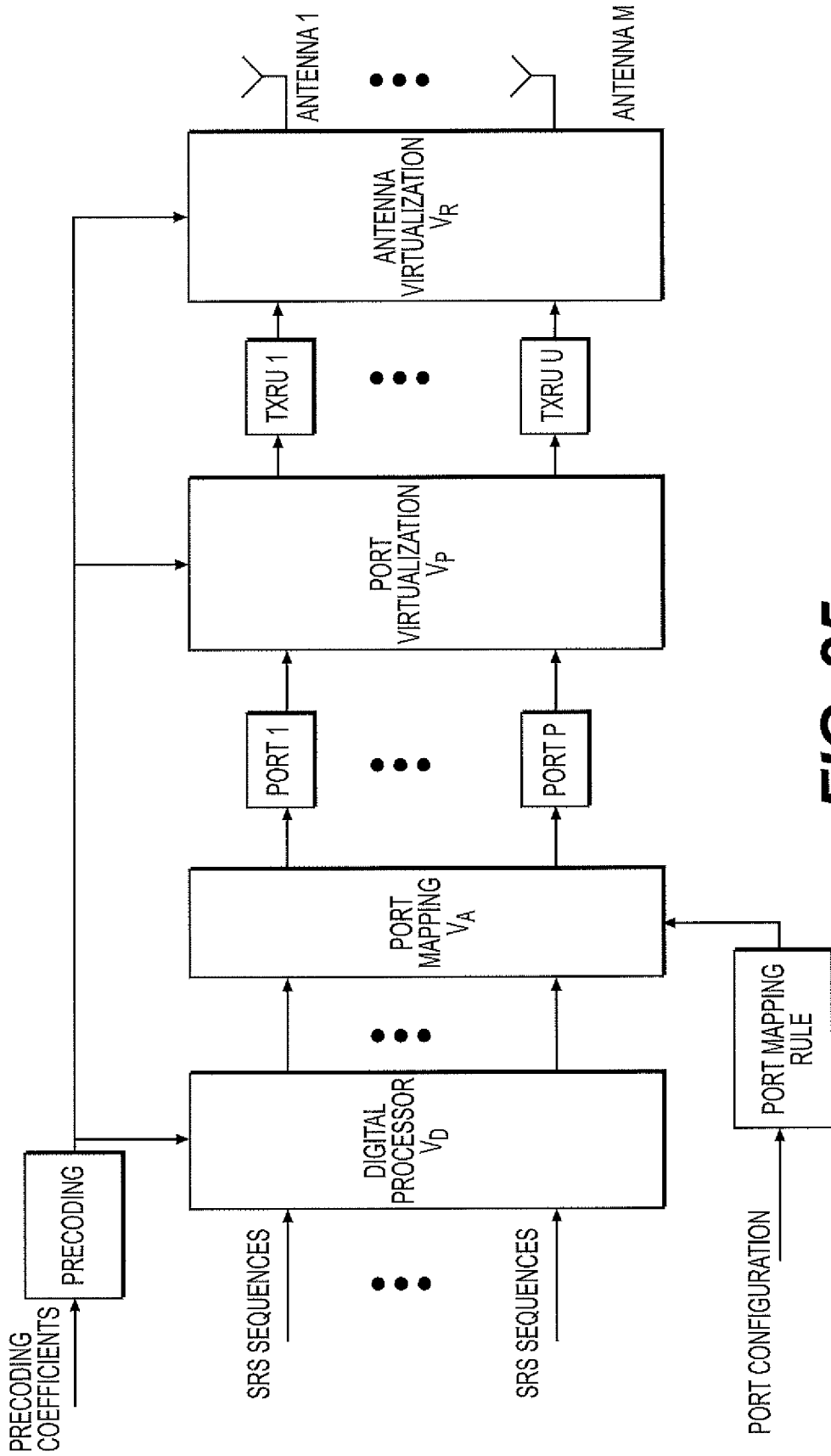
**FIG. 22**



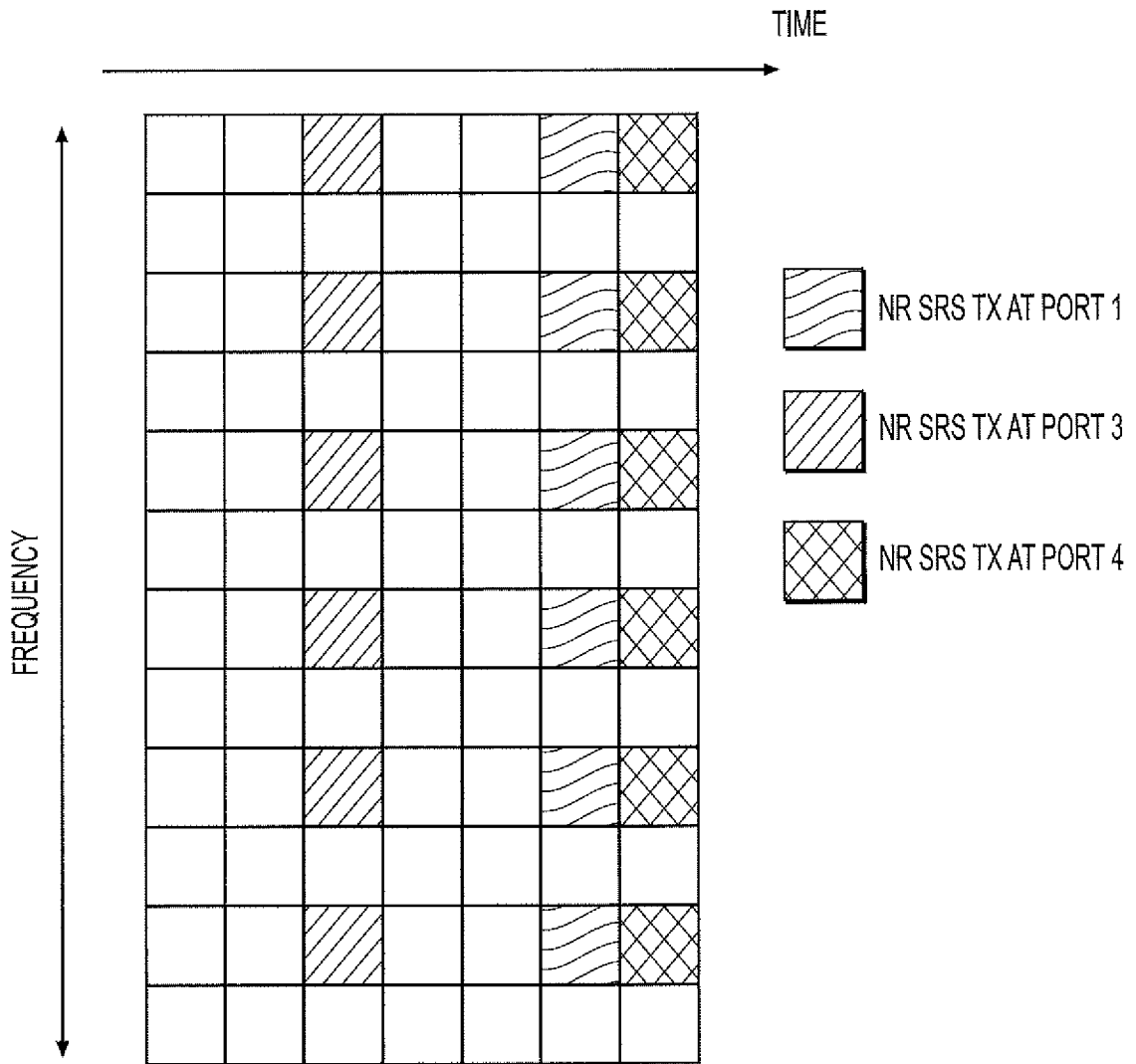
**FIG. 23**



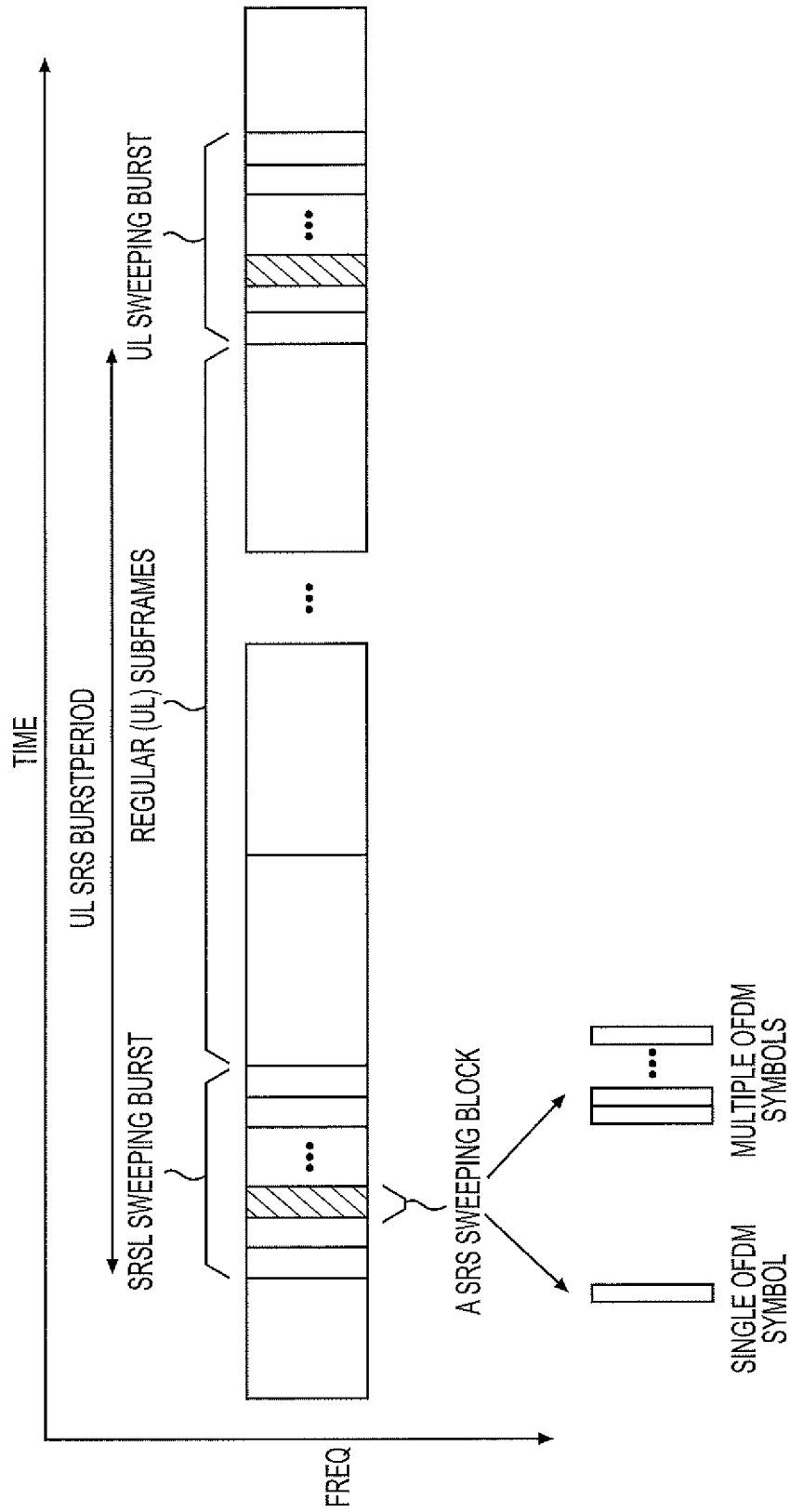
**FIG. 24**



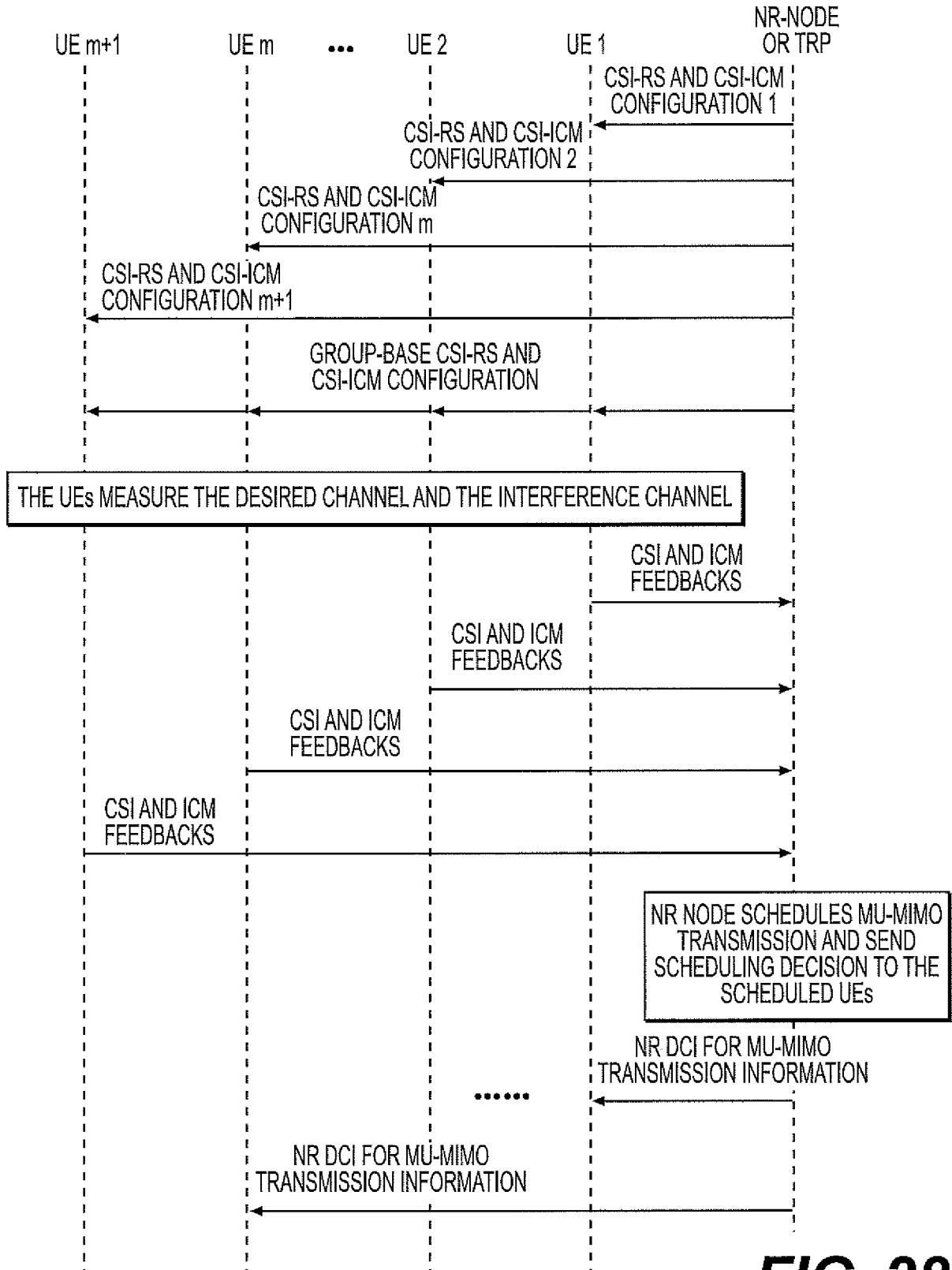
**FIG. 25**



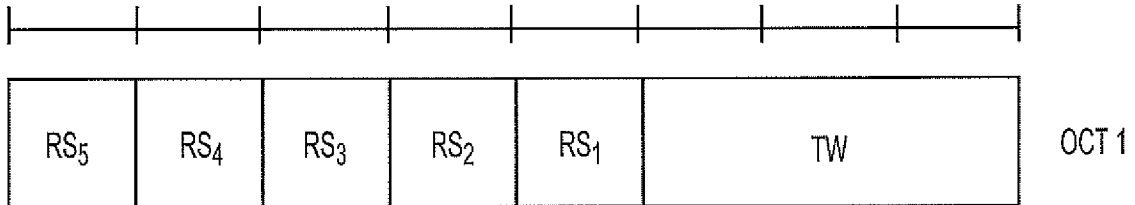
**FIG. 26**



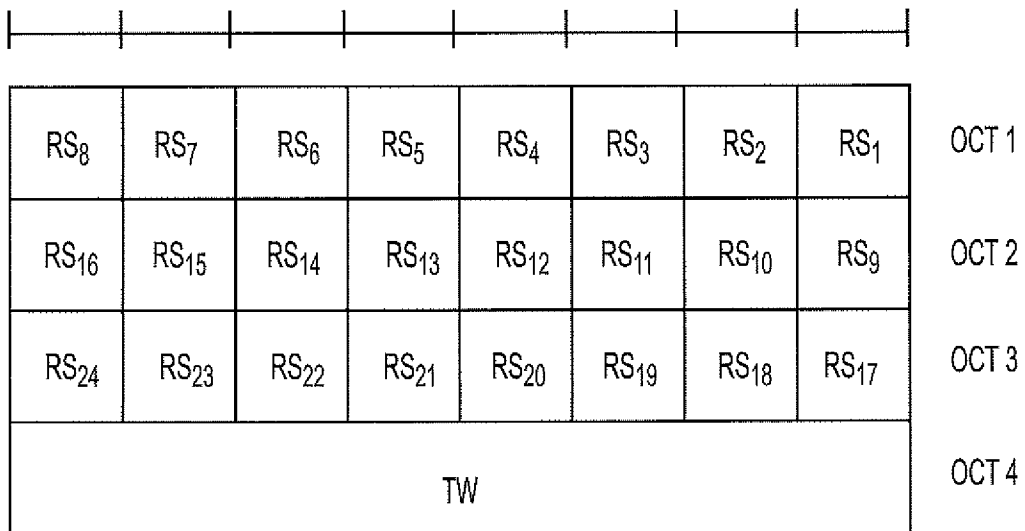
**FIG. 27**



**FIG. 28**



**FIG. 29**



**FIG. 30**

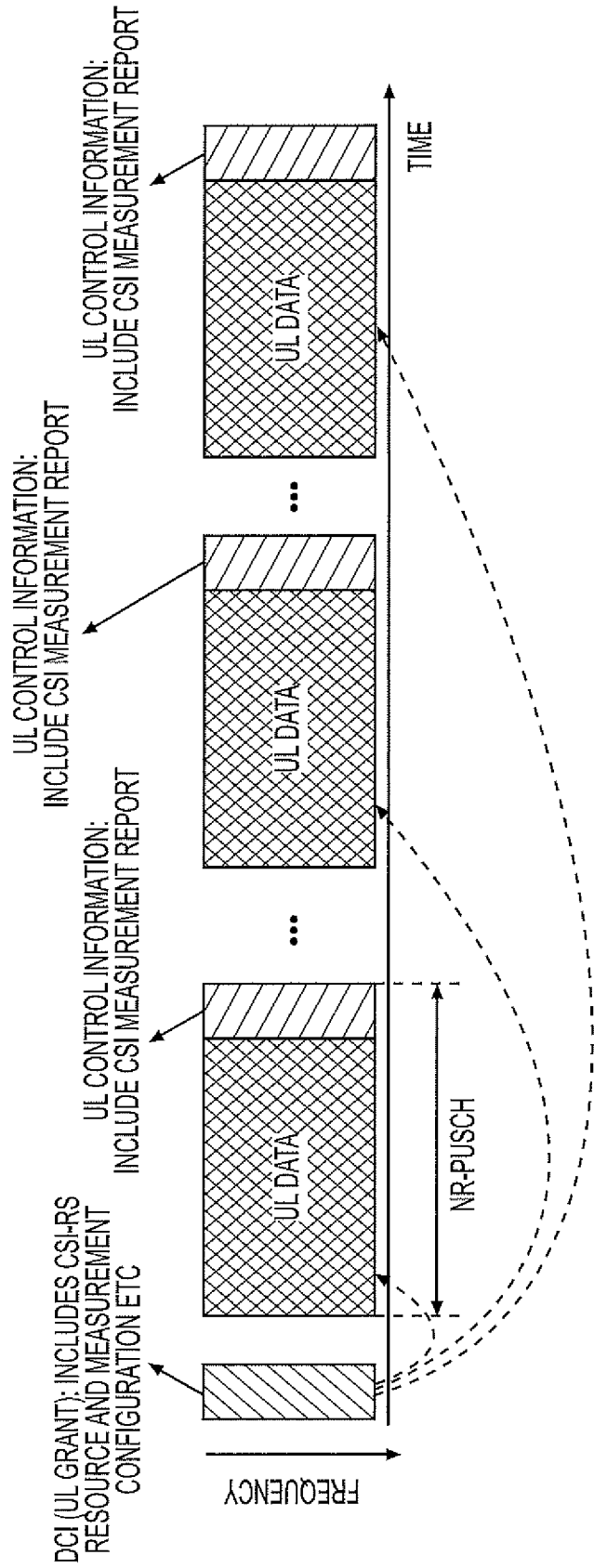
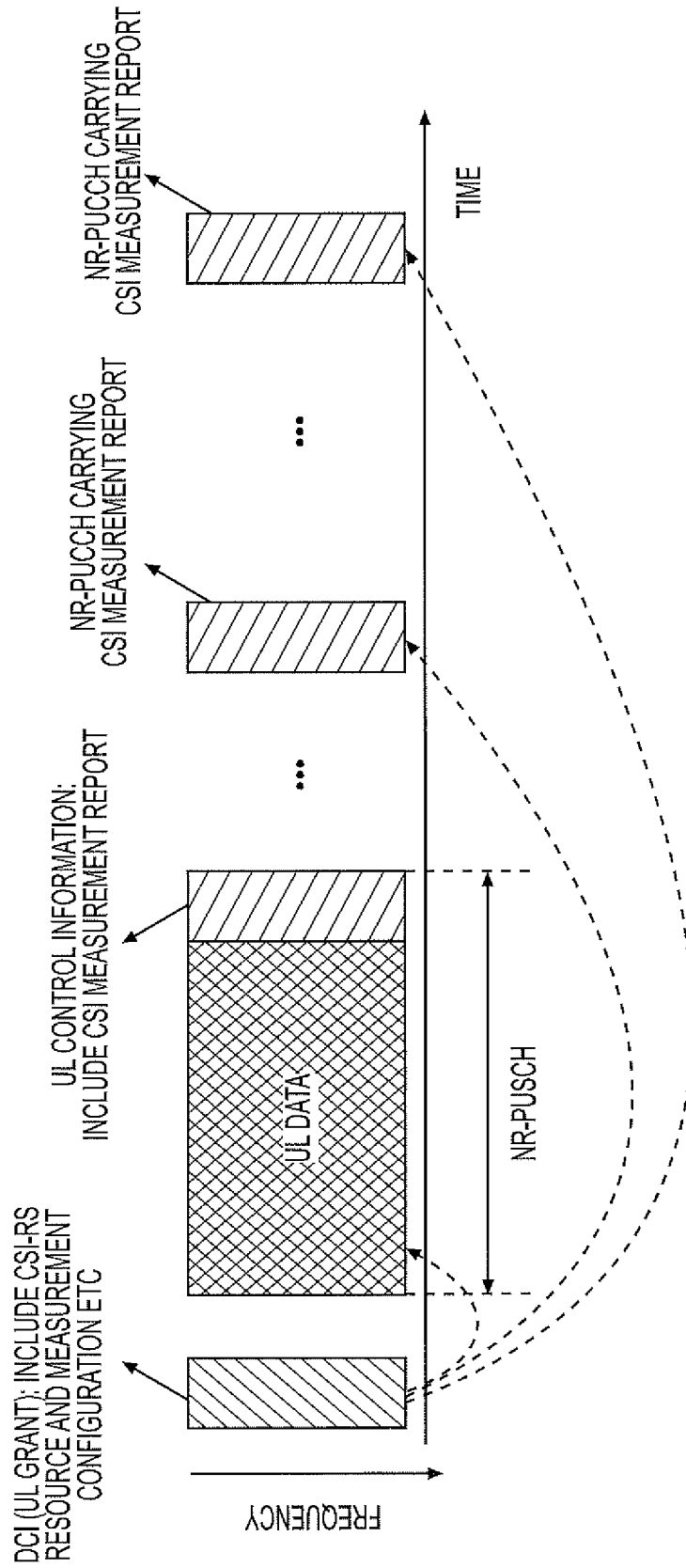
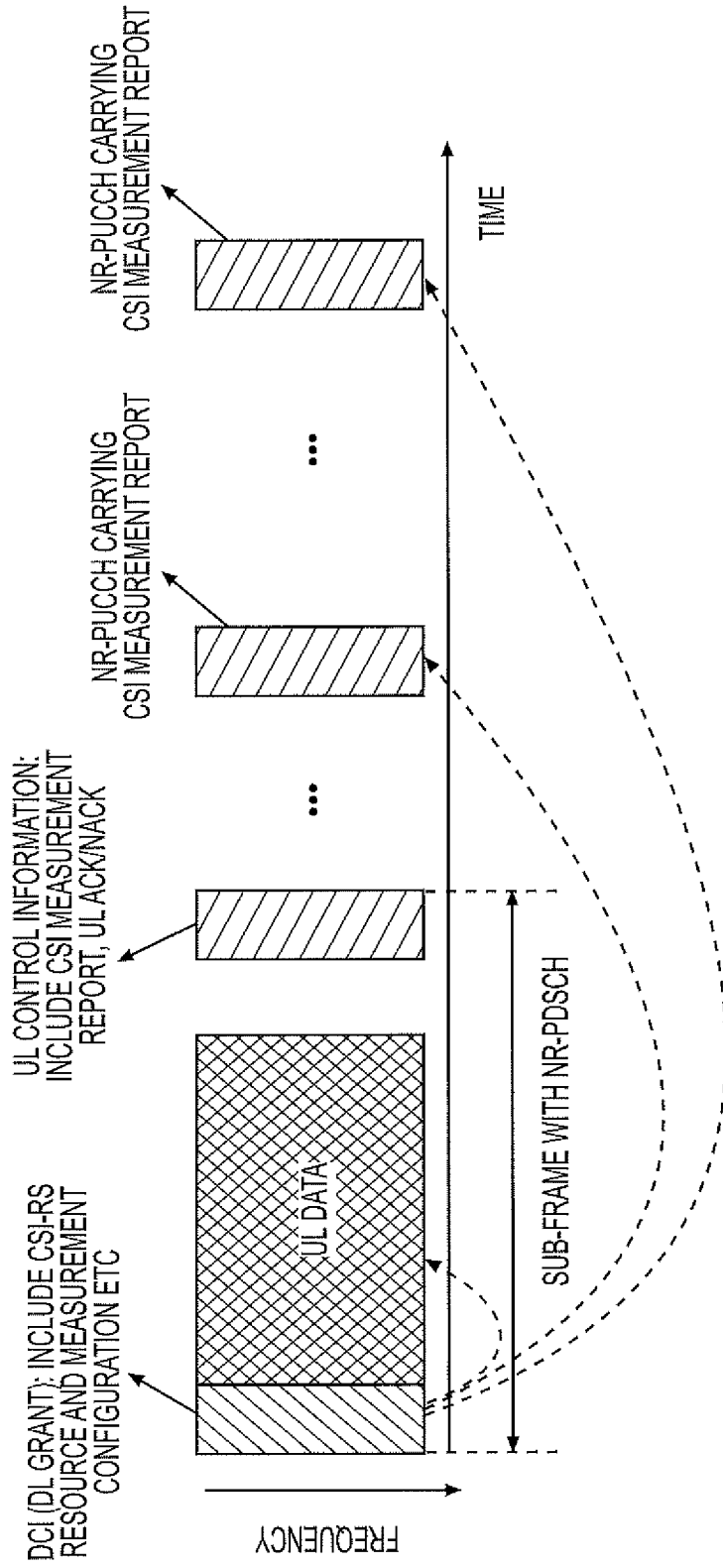


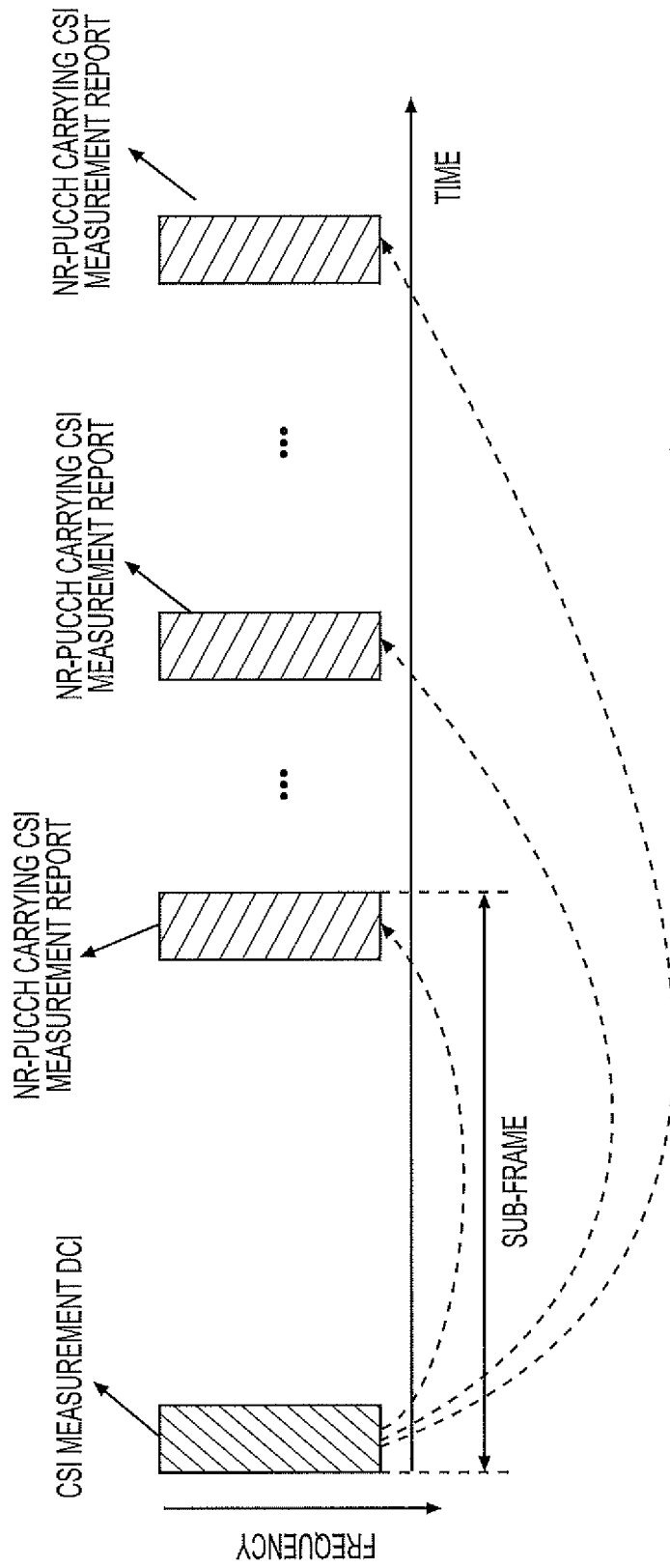
FIG. 31



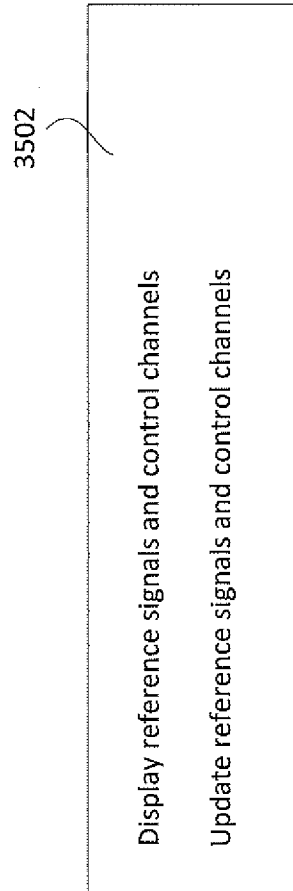
**FIG. 32**



**FIG. 33**



**FIG. 34**



**FIG. 35**

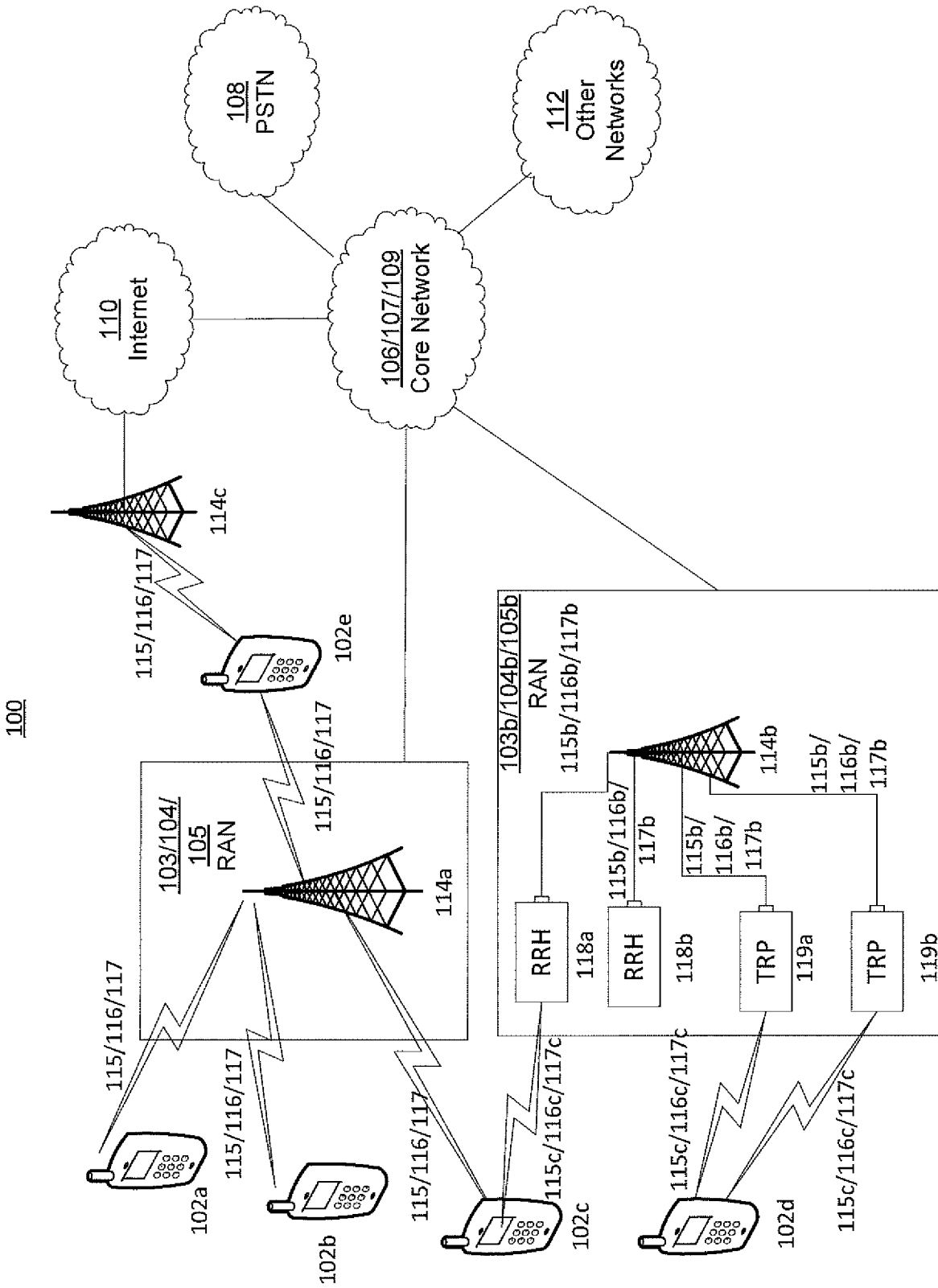


FIG. 36A

37/41

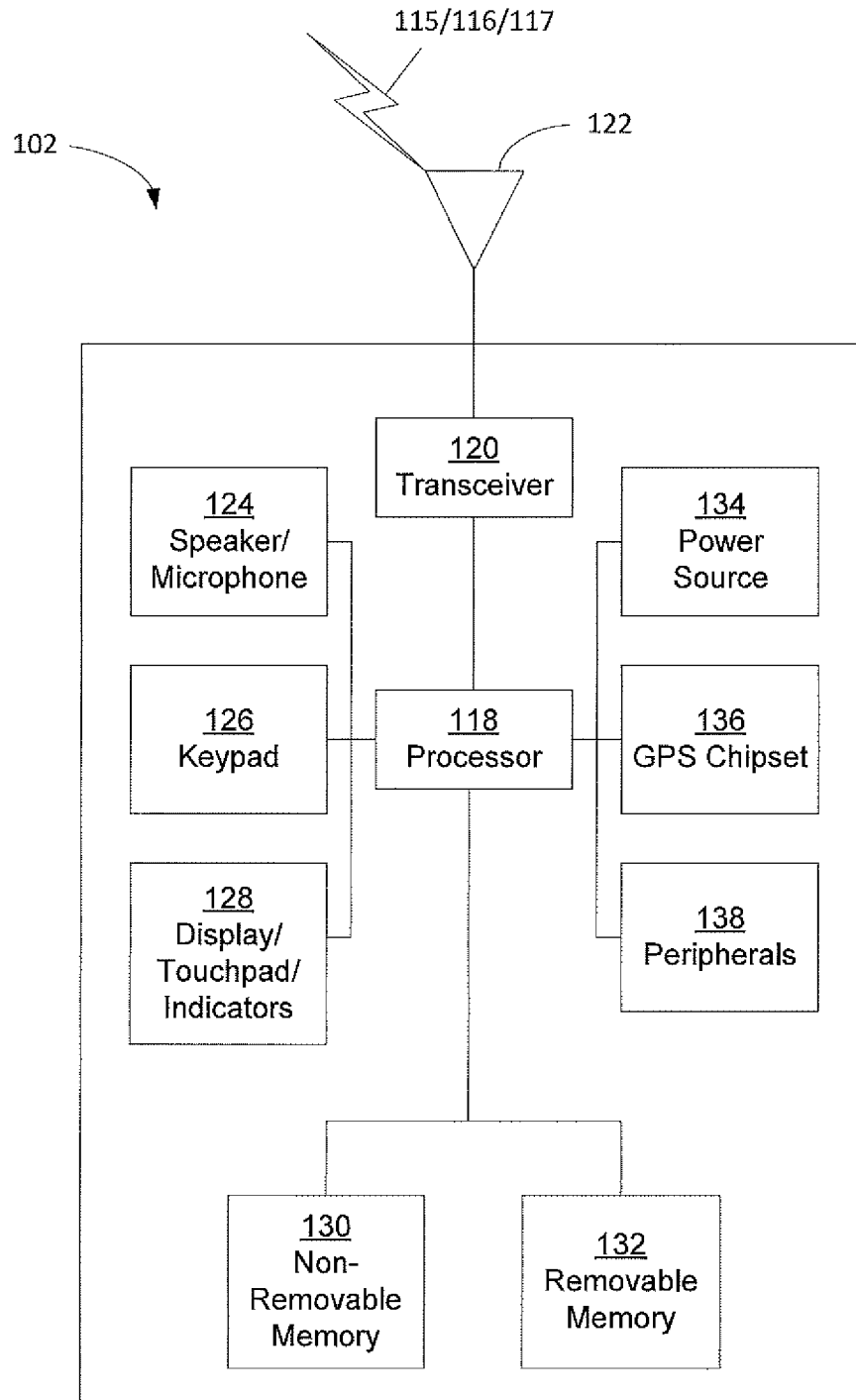
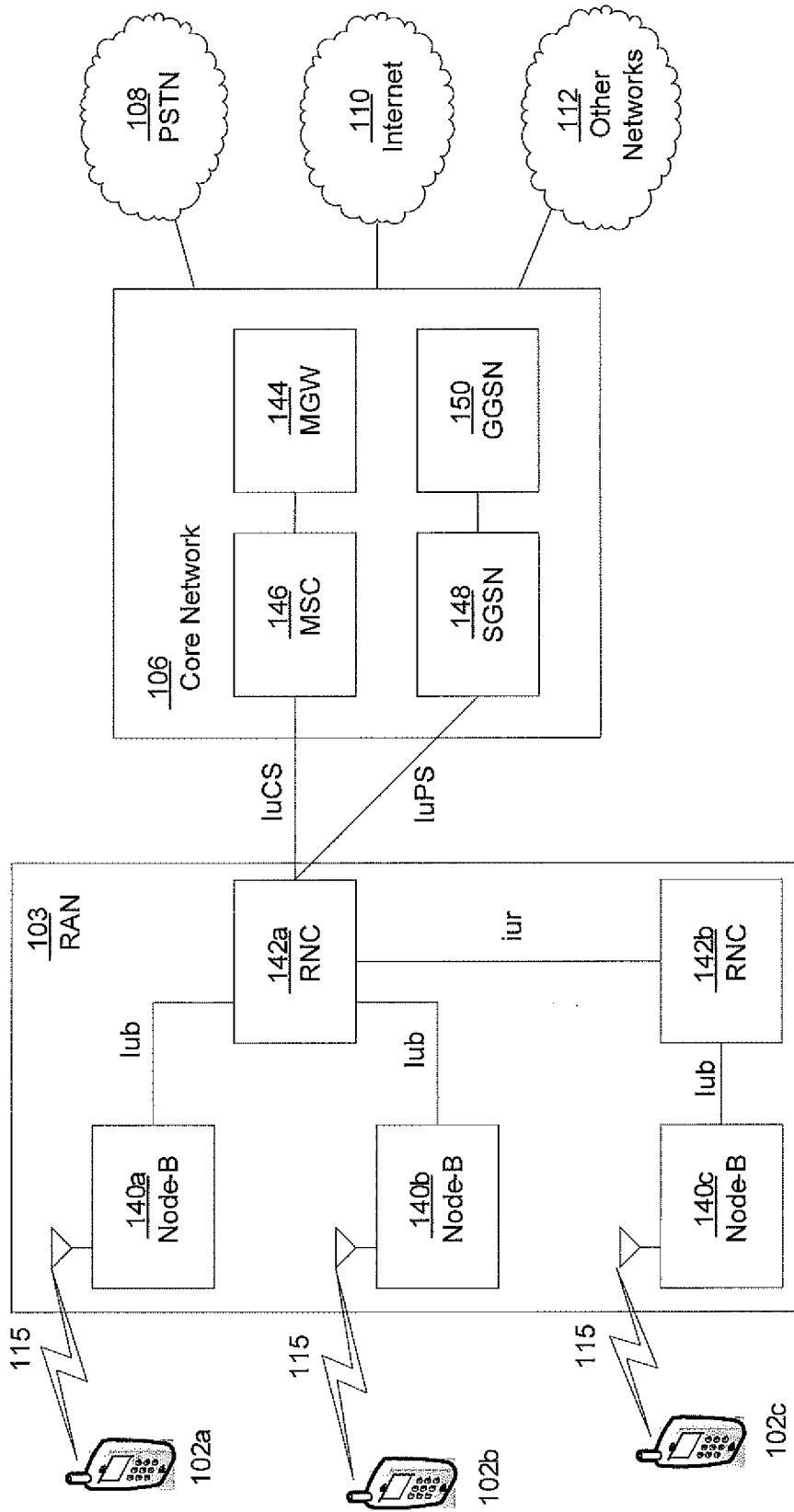


FIG. 36B



**FIG. 36C**

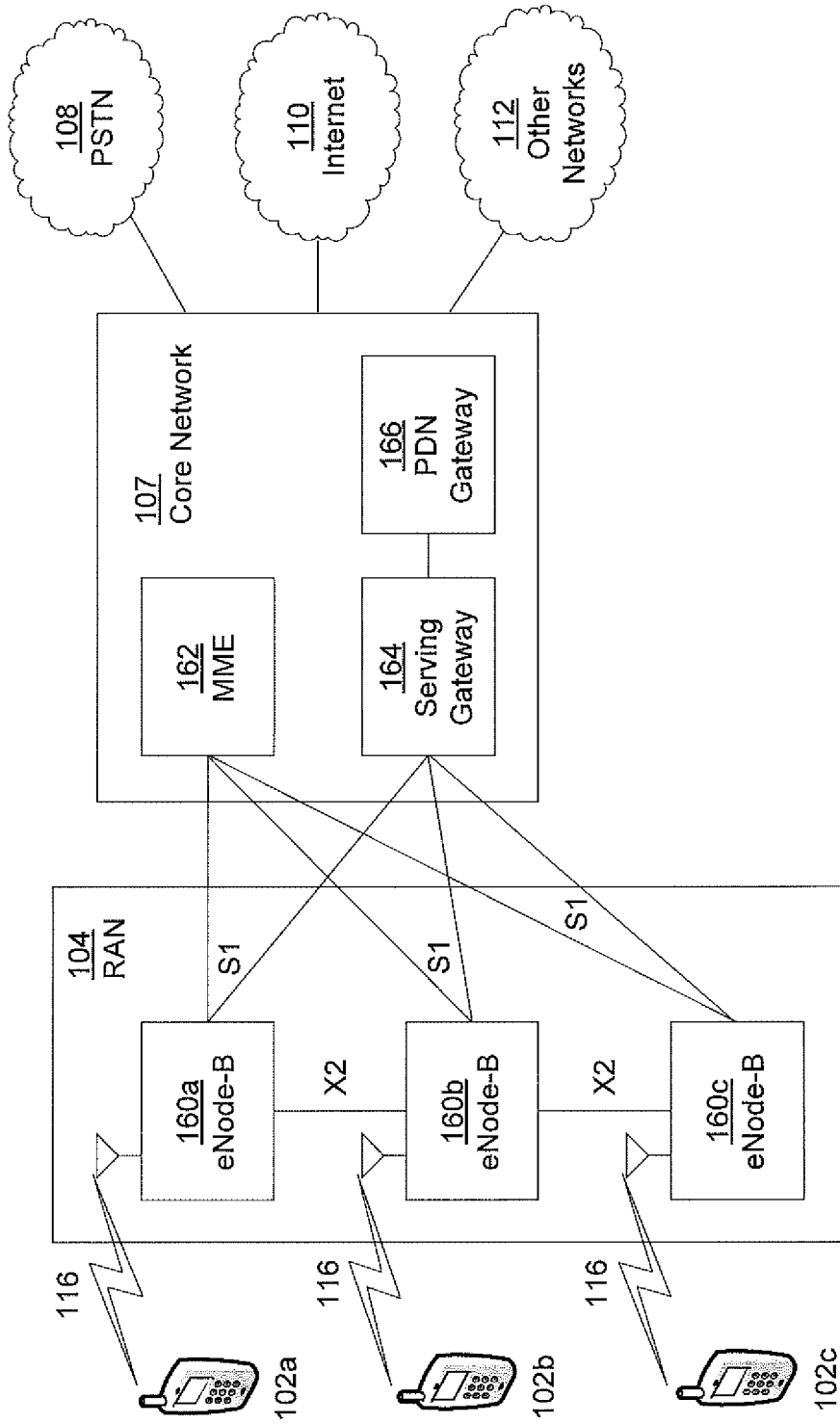


FIG. 36D

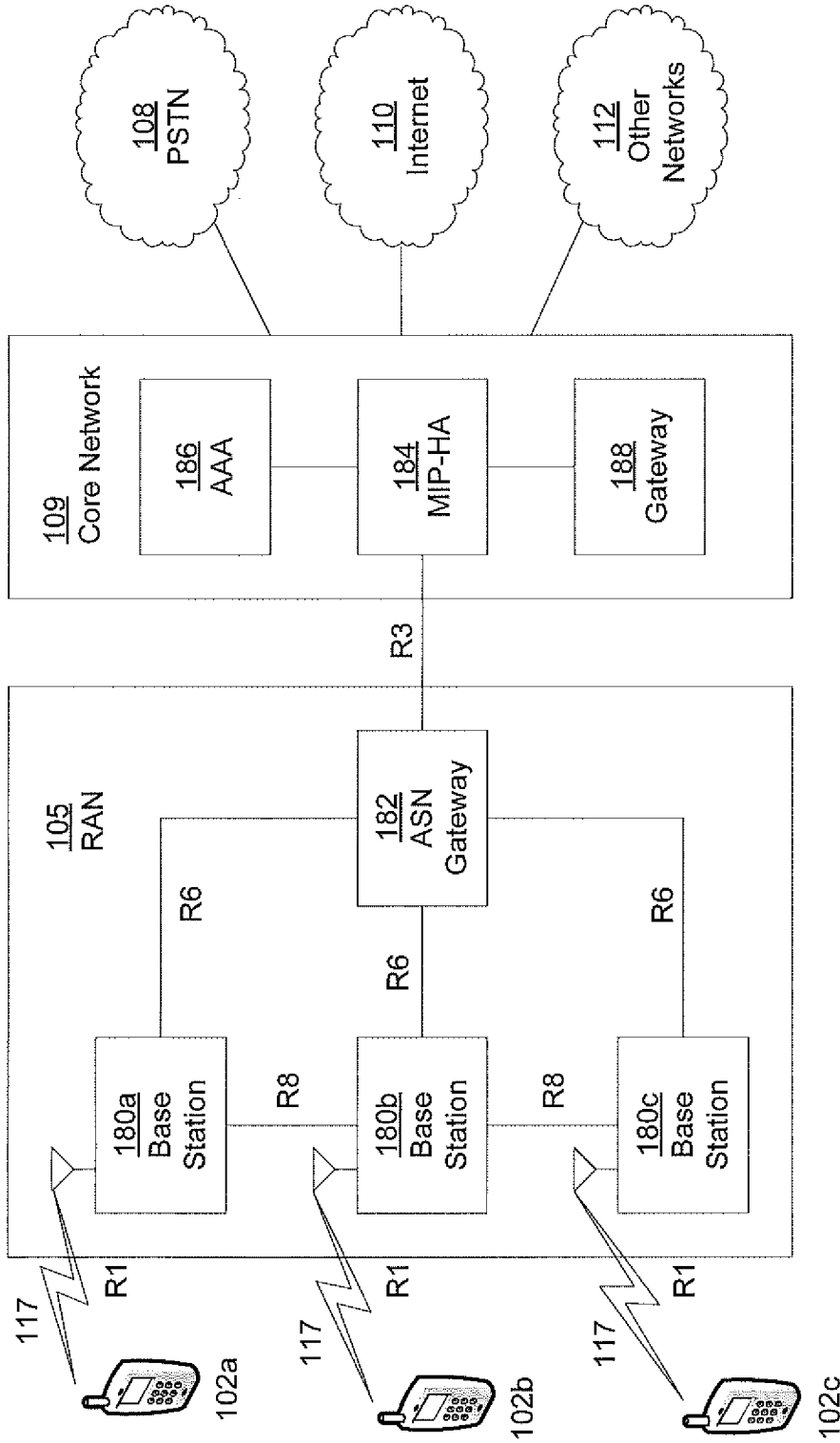


FIG. 36E

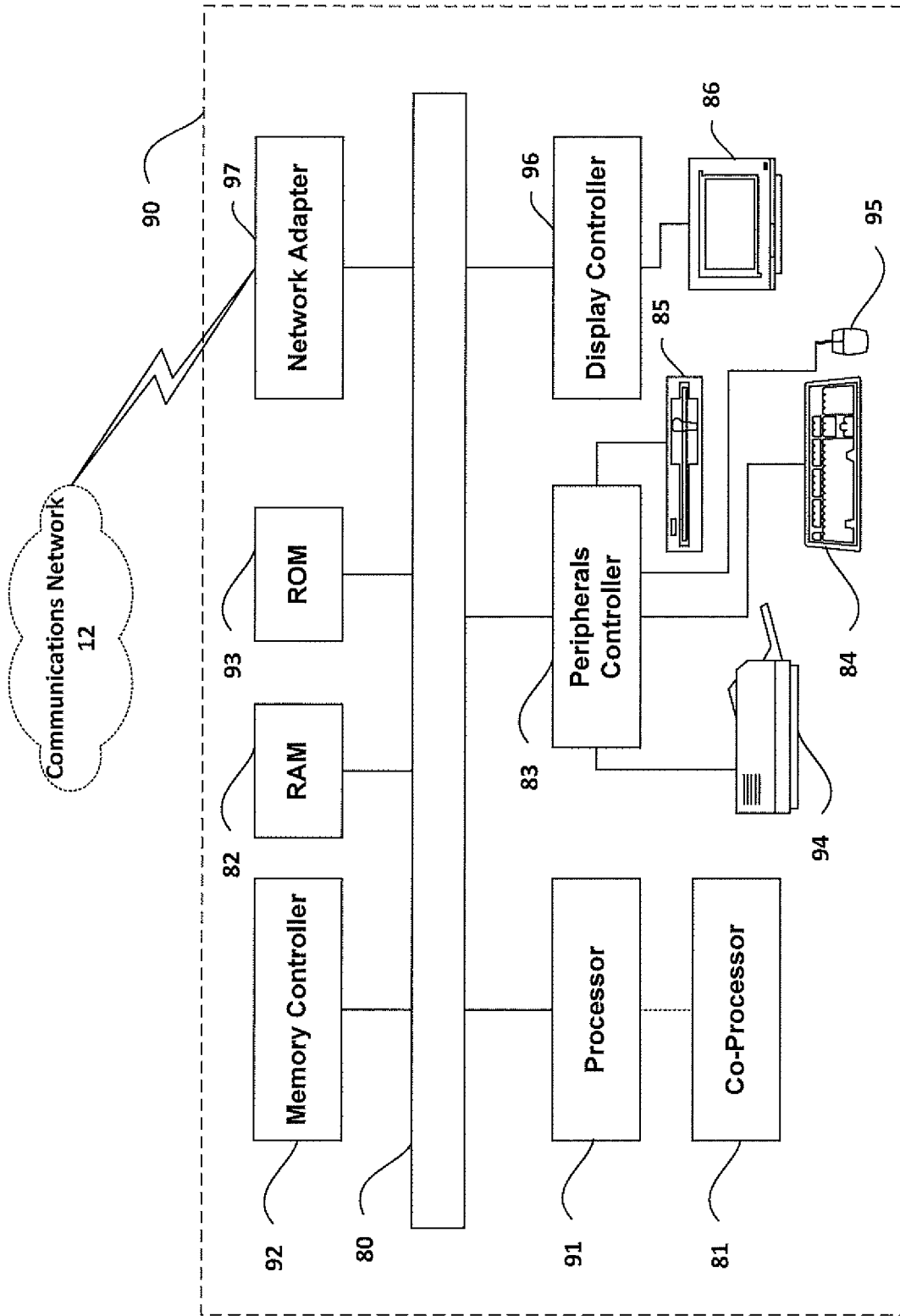


FIG. 36F