

*Printer's mistake
for 5-24-92 to back
turn over 74 pages
& look backward.*

(No Model.)

2 Sheets—Sheet 1.

E. SAMPER.

MACHINE FOR EXTRACTING FIBER FROM AGAVES, &c.

No. 524,956.

Patented Aug. 21, 1894.

Fig. 1

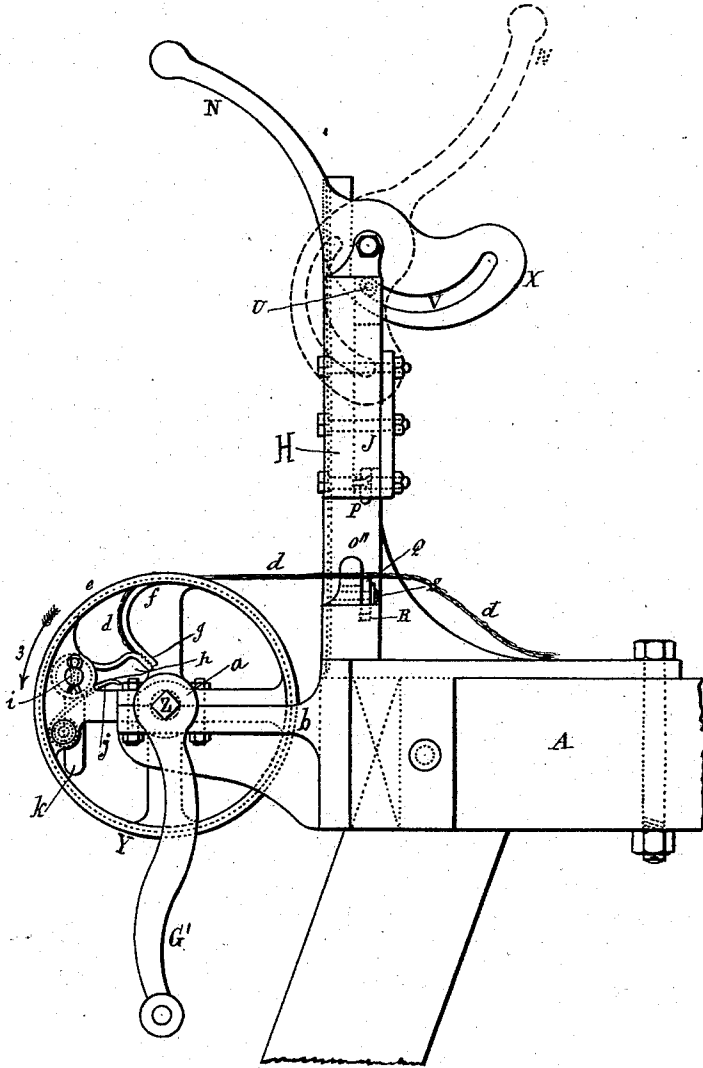

*Witnesses
William Miller
Chas. E. Poengen*

*Inventor
Eduardo Samper
by Hauff & Hauff
His Attorneys*

Printer's mistake
524924 back one sheet
and runs to 524956 - backwards

(No Model.)

2 Sheets—Sheet 2.

E. SAMPER.

MACHINE FOR EXTRACTING FIBER FROM AGAVES, &c.

No. 524,956.

Patented Aug. 21, 1894.

Fig. 2

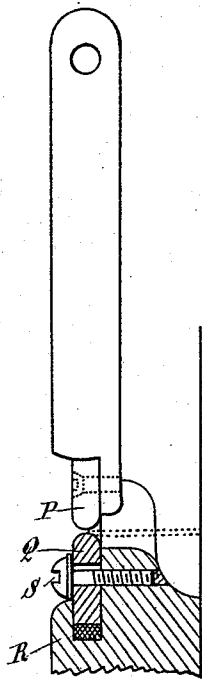
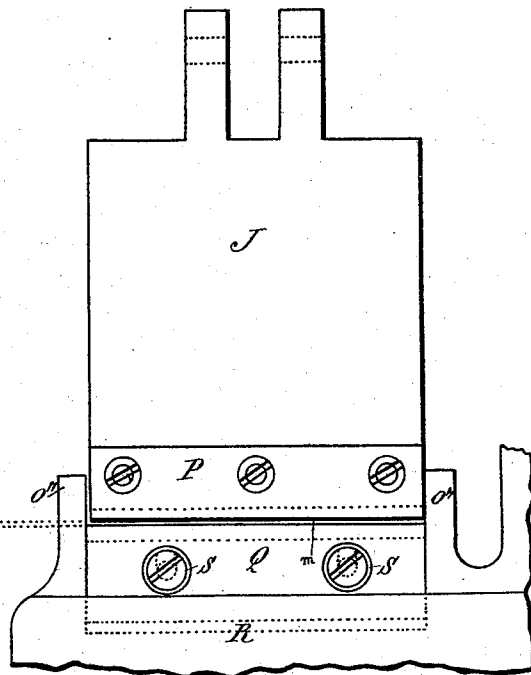

Fig. 3



Witnesses

William Miller
Chas. E. Penzger.

Inventor
Eduardo Samper
by *Hault & Hault*
His Attorneys

UNITED STATES PATENT OFFICE.

EDUARDO SAMPER, OF PARIS, FRANCE.

MACHINE FOR EXTRACTING FIBER FROM AGAVES, &c.

SPECIFICATION forming part of Letters Patent No. 524,956, dated August 21, 1894.

Application filed December 8, 1893. Serial No. 493,182. (No model.)

To all whom it may concern:

Be it known that I, EDUARDO SAMPER, a citizen of Bogota, in the Republic of Colombia, and a resident of Paris, in the Republic of France, have invented a new or Improved Machine for Extracting Fiber from Agaves, Aloes, and other Similar Plants, of which the following is a specification.

My invention relates to a new machine for extracting fibrous matter from agaves, aloes and other similar plants and is intended as a substitute for the apparatuses at present in use and which as a rule are very complicated, too expensive and requiring a moving power out of proportion with their yield, thus rendering them unfit for being used by small growers.

In order that my invention may be more clearly understood, I refer to the annexed drawings, in which—

Figure 1 illustrates a side view of my apparatus. Fig. 2 is an enlarged side view partly sectional of the sliding plate J, and Fig. 3 a front view of Fig. 2.

In all the figures, the same letters indicate corresponding parts.

A is an iron or wooden frame.

H is a cast-iron frame holding a sliding plate J moving vertically in grooves by means of an eccentric lever N. The sliding plate J is fitted with a horizontal blade P which on being brought down to its lowest position, is situated at about one millimeter's distance from another horizontal blade Q parallel to it and resting on an elastic stand or seat R made of india rubber or consisting of a flexible plate, a spring or the like. This blade Q slides vertically in a groove wherein it is held loosely by means of screws S, so that by strongly pressing on its upper rounded part this blade Q yields and is lowered vertically according to the pressure applied. The upper portion of the sliding plate has the shape of a pulley frame, crossed by a bolt bearing a small friction roller U running in the opening V cut in the eccentric lever N. This eccentric lever serves to move the sliding plate upward and downward. It is easy to see as in Fig. 1 that when the lever N is in the position represented in full lines, the sliding plate is at its highest and when the lever is in the position

represented by the dotted lines it is at its lowest which is the result of the movement of the friction roller U in the opening V.

In Fig. 1 I have illustrated by dotted lines the lowest position of the lever N and in that position the part X of the eccentric lever rests upon the upper side of the sliding plate J which has been brought down to its lowest position. The result is that any effort to raise the sliding plate is powerless to move the latter, the upper side of which strikes against the part X.

Y is a drum keyed on an axle Z and resting on two bearings *a a* fixed at the end of two arms *b b*.

G' is a crank.

The drum Y must be placed so that its upper part shall be in the same plane or nearly so as the lower part of the sliding plate J, when this latter is in its lowest position. The drum Y is arranged so as to cause the leaf of the plant *d* to adhere to its circumference in order to submit it to the action of the sliding plate J. This arrangement consists in cutting the periphery of the drum and in folding up a certain portion of the said periphery toward the center of the drum as shown by the curved line *f g* (Fig. 1) producing at the same time an opening *e*. A block or brake *h* movable around an axle *i* is held by a spring *j* against the lower part *g* of the curve.

k is a lever fixed upon the axle *i* keyed on a projection placed in the inside of the drum Y, to allow of removing the block *h* at will from the surface corresponding to *g*.

If any fibrous matter *d* is introduced into the free space *e* until these fibers descend between point *g* and point *h*, that is, in the opening produced between these two surfaces when the block *h* is moved outward by the lever *k*, and if the lever *k* is released, the force imparted to the block by the spring raises the latter which adheres to the portion *g*, producing such a pressure that if at that moment the drum is caused to revolve in the direction pointed out by the arrow 3, the fibers will adhere between the block and part *g* and consequently on the surface *f g* according to the traction employed, the surfaces *g h* acting as jaws which seize and retain the leaves.

To extract the fibrous matter I proceed as

follows: I begin to cut up the leaves to be decorticated into longitudinal strips by means of cutters or any other suitable means. I then submit the leaves by taking them of course by hand each strip separately to the action of any corrugated cylinders such as are commonly used which begin to soften and flatten out the leaves and then place each of them thus crushed on the blade Q between the cheeks *o'' o''* of aperture *m, i. e.* under sliding plate J. This being done I draw out the leaf lengthwise and introduce the broader end into the opening *e* of the drum Y till it is seized by the block *h*. Afterward I draw back the lever N and the rounded blade P then presses on the strips *d d*. I rotate the drum in the direction of the arrow 3, (Fig. 1) said drum carrying along with it the strip or leaf and the pressure effected by both blades P and Q being regularized by the elastic fitting and combined with the traction of the drum, suffices to rid the fiber of the parenchyma and all other substances without breaking the fiber. After the end of the fibrous strip has come out of the jaws P and Q, I revolve the drum in the opposite direction in order to effect its unrolling and I move the lever *k* removing the block *h* and the

fibrous strip is thus liberated. If I wish to economize the raw material I pass my strip over again in the opposite direction in order to rid the other end of the substances still adhering to it. I proceed in the same way for every strip to be unfibered and I thus obtain fibers which have only to be subjected to the usual operations of washing.

What I claim as new, and desire to secure by Letters Patent, is—

A machine for extracting the fibrous matter of agaves, aloes and similar leaves, said machine comprising a drum Y having a cut or aperture in its circumference, a curved lip *f g* extending from the aperture into the drum, a shaft *i* in said drum, a brake *h* on said axle, and a spring *j* for holding the brake against the lip *f g*, combined with a sliding plate J having an edge plate P, a second plate Q, an elastic or yielding support R for the said plate Q, and an actuating lever for moving the plate J to carry the edge plate P to and from the plate Q, substantially as described.

EDUARDO SAMPER.

Witnesses:

C. H. CONAILLON,
C. DEGRANGE.