

July 28, 1964

A. B. MCKENZIE

3,142,438

MULTI-STAGE AXIAL COMPRESSOR

Filed April 12, 1962

3 Sheets-Sheet 1

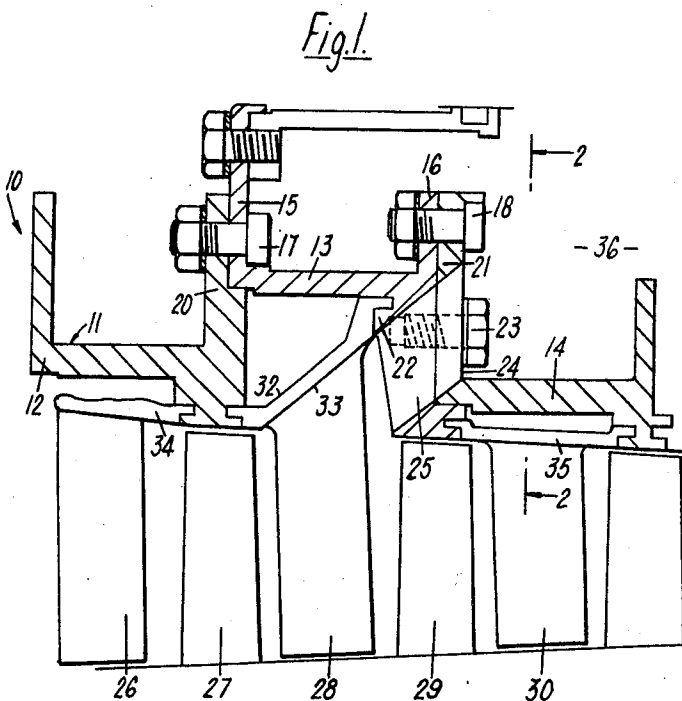

Inventor
Archibald Bathgate McKenzie
By
Cushman, Darby & Cushman
Attorneys

July 28, 1964

A. B. MCKENZIE

3,142,438

MULTI-STAGE AXIAL COMPRESSOR

Filed April 12, 1962

3 Sheets-Sheet 2

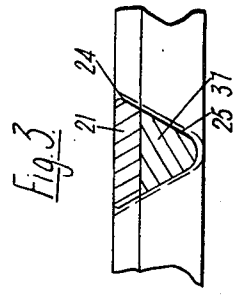
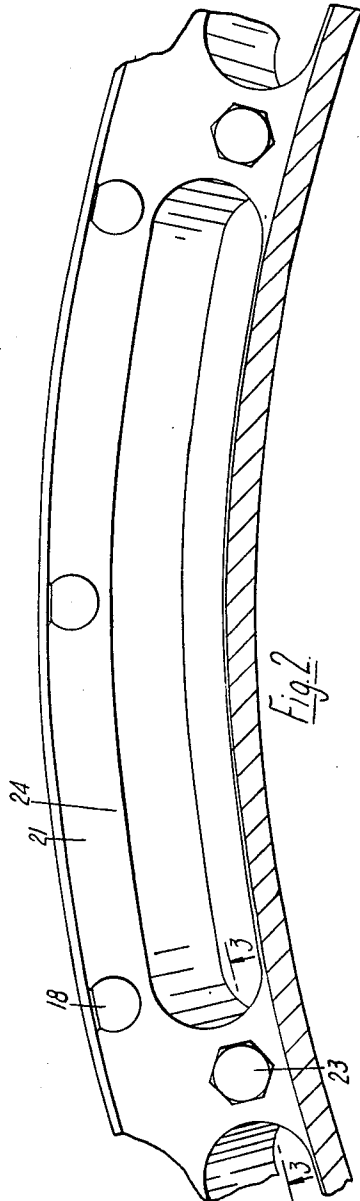

Inventor
Archibald Bathgate McKenzie
By
Cushman, Darby & Cushman
Attorneys

July 28, 1964

A. B. MCKENZIE

3,142,438

MULTI-STAGE AXIAL COMPRESSOR

Filed April 12, 1962

3 Sheets-Sheet 3

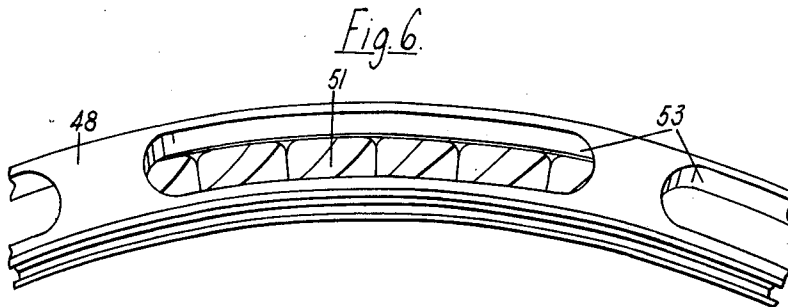
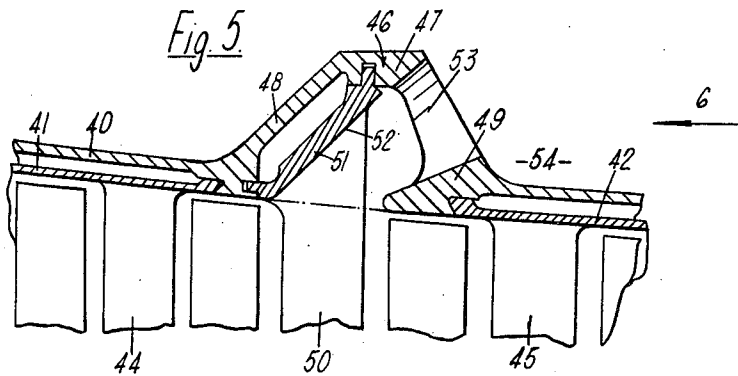
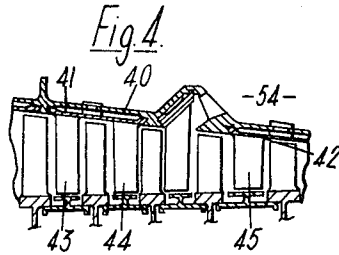

Inventor
Archibald Bathgate McKenzie
By
Cushman, Darby & Cushman
Attorneys

1

2

3,142,438

MULTI-STAGE AXIAL COMPRESSOR

Archibald Bathgate McKenzie, Littleover, England,
assignor to Rolls-Royce Limited, Derby, England,
a company of Great Britain

Filed Apr. 12, 1962, Ser. No. 186,988

Claims priority, application Great Britain Apr. 21, 1961
6 Claims. (Cl. 230—122)

This invention concerns a multi-stage axial compressor, e.g. for a gas turbine engine.

Multi-stage axial compressors are known which have a bleed air passage through which some of the air compressed by the compressor may be bled from one of the stages of the compressor, the said stage having stator blades whose platforms have radially extending apertures through which some of the said compressed air may pass to the bleed air passage. This arrangement, however, is unsatisfactory if it is required to bleed large quantities of the said compressed air into the bleed air passage both because it may not be possible to make the total area of the said apertures sufficiently large and because the bleeding of large quantities of compressed air through these apertures may involve serious aerodynamic losses.

Accordingly therefore to the present invention, there is provided a multi-stage axial compressor having a bleed air passage through which some of the air compressed by the compressor may be bled from one of the stages of the compressor, the said stage having stator blades each of whose platforms is provided with at least one surface which is so inclined with respect to the axis of the compressor as to direct some of the said compressed air radially outwardly and in a downstream direction towards the bleed air passage.

Preferably the downstream end of each said inclined surface is disposed radially outwardly of the platforms of the stator blades of the adjacent stage or stages of the compressor.

Preferably the compressor, on the downstream side of the stator blades of the said stage, has a wall having an apertured portion which communicates with the bleed air passage and the said inclined surfaces being adapted to direct some of the said compressed air through said apertured portion.

Each said inclined surface may be inclined at an angle of substantially 40° to 50° to the longitudinal axis of the compressor.

The compressor may, if desired, have a casing having a wall which is inclined radially outwardly in a downstream direction, the stator blades of the said stage being mounted in the casing so that their platforms extend parallel to said wall.

The invention also comprises a gas turbine engine provided with a compressor as set forth above.

Additionally the invention comprises an aircraft provided with such a gas turbine engine, the bleed air passage being arranged to supply compressed air to blown flaps on the aircraft.

The invention is illustrated, merely by way of example, in the accompanying drawings in which:

FIGURE 1 is a broken away axial section of part of a multi-stage axial compressor according to the present invention,

FIGURE 2 is broken away section taken on the line 2—2 of FIGURE 1,

FIGURE 3 is a broken away section taken on the line 3—3 of FIGURE 2,

FIGURE 4 is a broken away axial section of part of another multi-stage axial compressor according to the present invention,

FIGURE 5 is a broken away section showing part of the structure of FIGURE 4 on a larger scale, and

FIGURE 6 is a broken away view taken in the direction of the arrow 6 of FIGURE 5.

Referring to FIGURES 1—3 of the drawings, a gas turbine engine (not shown) for use on an aircraft (not shown) comprises a multi-stage axial compressor 10 having compressor casing means 11. The compressor casing means 11 is made up of a number of wall members including annular U-section, wall members 12, 13, 14.

The wall member 13 has radially outwardly extending annular walls 15, 16 which are respectively secured by bolts 17, 18 to radially outwardly extending annular walls 20, 21 of the wall members 12, 14 respectively. The wall member 13 is also provided with a radially inwardly extending annular wall 22 which is secured to the wall 21 by bolts 23.

The walls 21, 22 are formed with a plurality of aligned, angularly spaced apart elongated slots 24, 25 respectively.

The compressor 10 includes regularly axially spaced fifth stage stator blades 26, sixth stage rotor blades 27, sixth stage stator blades 28, seventh stage rotor blades 29, and seventh stage stator blades 30. All of these blades 26 to 30 have a conventional straight-edged aerofoil configuration, and all the rotor blades 27, 29 are completely shrouded by the compressor casing means 11.

The sixth stage stator blades 28 extend radially outwardly across a bleed passage generally denoted by the reference numeral 36, and have integral platforms 32 opposite ends of which are mounted in the walls 20, 22. The platforms 32 have internal surfaces 33 which are inclined at an angle of 40° to 50° to the longitudinal axis of the compressor 10 and which together form a fluid-tight radially inwardly facing surface of the bleed air passage. The downstream ends of the inclined surfaces 33 are disposed radially outwardly of the platforms 34, 35 of the stator blades 26, 30 of the adjacent stages of the compressor.

The main fluid duct of the compressor is thus bounded by the inner surfaces of a first section of the compressor casing means, comprising the platforms 34 and the wall member 12; a second section axially spaced from the first section and comprising the annular wall 22, the platforms 35 and the wall member 14; and an intermediate section extending between the first and second sections and comprising the platforms 32. The inner surface of the first section has a downstream end, formed by part of the wall member 12, which is aligned axially of the compressor with the inner surface of the upstream end of the second section, formed by the annular wall 22. Furthermore, the inner surface of the intermediate section comprising the surfaces 33 diverges outwardly from the downstream end of the inner surface of the first section towards and in radially outwardly spaced relationship to the upstream end of the second section, the inner surface of the intermediate section and the upstream end of the second section defining an annular space therebetween.

The inclined surfaces 33 are adapted to direct some of the air which has been compressed by the compressor radially outwardly and in a downstream direction so that this air will flow smoothly through the elongated slots 24, 25 and the bleed air passage 36.

The slots 24, 25 (see FIGURE 3) have inwardly inclined walls, the ribs 37 which are formed between the slots 25 being smoothly rounded at their upstream ends to reduce pressure losses.

Means (not shown) may be provided for closing the slots 24, 25 (or, alternatively, for preventing flow through the bleed air passage 36) whenever it is no longer necessary to bleed air from the compressor 10.

It will be appreciated that the construction described above enables large quantities of compressed air to be

3

withdrawn through the slots 24, 25 and into the bleed air passage 36. This large quantity of compressed air may, for example, be used for the operation of blown flaps on the said aircraft.

In FIGURES 4-6 there is shown a modified multi-stage axial compressor according to the present invention having a casing 40. Within the casing 40 there are mounted inner wall members 41, 42, the inner wall member 41 carrying fourth and fifth stage stator blades 43, 44 respectively and the inner wall member 42 carrying seventh stage stator blades 45.

The casing 40 has a radially outwardly extending projection 46. The projection 46 has an axially extending wall 47 and inclined upstream and downstream walls 48, 49 respectively, the wall 48 being radially outwardly inclined in a downstream direction.

Sixth stage stator blades 50 are mounted in the casing 40 and have platforms 51 which extend parallel to the wall 48. The platforms 51 have internal surfaces 52 which are inclined at an angle of about 45° to the longitudinal axis of the compressor. The downstream ends of the inclined surfaces 52 are disposed radially outwardly of the platforms of the stator blades 44, 45 of the adjacent stages of the compressor.

The wall 49 has angularly spaced apart elongated slots 53 therein. The inclined surfaces 52 are adapted to direct some of the air compressed by the compressor radially outwardly and in a downstream direction so that this air will flow smoothly through the elongated slots 53 and so to a bleed air passage 54.

I claim:

1. In a multi-stage axial compressor suitable for intermittent bleeding of compressed air therefrom and having a longitudinal axis, a main fluid duct, and casing means for said main fluid duct, said casing means comprising first and second axially spaced sections and an intermediate section extending between said first and second sections, each of said sections having an inner surface which forms an outer boundary wall of a respective axial portion of said main fluid duct, the inner surface of said first section having a downstream end, and the inner surface of said second section having an upstream end which is aligned axially of the compressor with the downstream end of the inner surface of said first section, the inner surface of said intermediate section being fluid tight and diverging outwardly relatively to the inner surfaces of the first and second sections from the downstream end of the inner surface of said first section towards and in radially outwardly spaced relationship to the upstream end of said second section, the inner surface of said intermediate section and the upstream end of said second section defining an annular space therebetween, said casing means being provided with duct means in fluid flow communication with said annular space for bleeding compressed air from said main fluid duct, the improvement comprising a plurality of angularly arranged stator blades provided in said intermediate section, each of the stator blades carrying at its radially outer end a platform formed integrally therewith and having a radially inwardly facing surface, the radially inwardly facing surfaces of said platforms of said stator blades together forming said fluid tight inner surface of said intermediate section.

2. A multi-stage axial compressor as claimed in claim 1, including a plurality of regularly axially spaced, bladed, alternate rotor and stator stages, all the individual blades

4

of said stages having a conventional straight-edged aerofoil configuration.

3. A multi-stage axial compressor as claimed in claim 2, in which all the blades of said rotor stages are completely shrouded by said first and second sections of the casing means.

4. A multi-stage axial compressor suitable for intermittent bleeding of compressed air therefrom, and having a compressor casing, a bleed air passage for bleeding compressed air from said compressor casing, said bleed air passage having a radially inwardly facing surface which extends outwardly of said compressor casing, a plurality of regularly axially spaced, alternate rotor and stator stages within said compressor casing, each stage comprising a plurality of angularly arranged blades, the blades of one of said stator stages extending radially outwardly of the compressor casing into the bleed air passage, each of said last mentioned blades carrying at its radially outer end a platform formed integrally therewith, the platforms together forming said radially inwardly facing surface of the bleed air passage, all the blades of said stages having a conventional straight-edged aerofoil configuration, and all the blades of said rotor stages being completely shrouded by said compressor casing, whereby when no compressed air is bled through the bleed air passage, the compressor operates efficiently.

5. A compressor as claimed in claim 4 in which said compressor casing comprises first and second axially spaced sections extending on axially opposite sides of said bleed air passage, each of said sections having an inner surface, the inner surface of said first section having a downstream end, and the inner surface of said second section having an upstream end which is aligned axially of the compressor with the downstream end of the inner surface of said first section, said radially inwardly facing surface of the bleed air passage being fluid tight and diverging outwardly relatively to the inner surfaces of the first and second sections from the downstream end of the inner surface of said first section towards and in radially outwardly spaced relationship to the upstream end of said second section, said radially inwardly facing surface of the bleed air passage and the upstream end of said second section defining an annular space therebetween through which compressed air bled from the compressor can flow.

6. A compressor as claimed in claim 4 in which said radially inwardly facing surface is inclined at an angle of substantially 40° to 50° to the longitudinal axis of the compressor.

References Cited in the file of this patent

UNITED STATES PATENTS

1,447,554	Jones	Mar. 6, 1923
2,520,697	Smith	Aug. 29, 1950
2,614,799	Judson et al.	Oct. 21, 1952
2,650,060	Stalker	Aug. 25, 1953
2,678,537	Stalker	May 18, 1954
2,702,157	Stalker	Feb. 15, 1955

FOREIGN PATENTS

889,506	Germany	Sept. 10, 1953
920,732	France	Jan. 4, 1947
1,012,339	France	Apr. 16, 1952
1,068,638	France	Feb. 10, 1954
1,099,669	France	Mar. 23, 1955
1,136,881	France	Jan. 7, 1957