

March 7, 1944.

N. WAHL

2,343,348

MAKING SEPARABLE FASTENERS

Filed Oct. 30, 1941

2 Sheets-Sheet 1

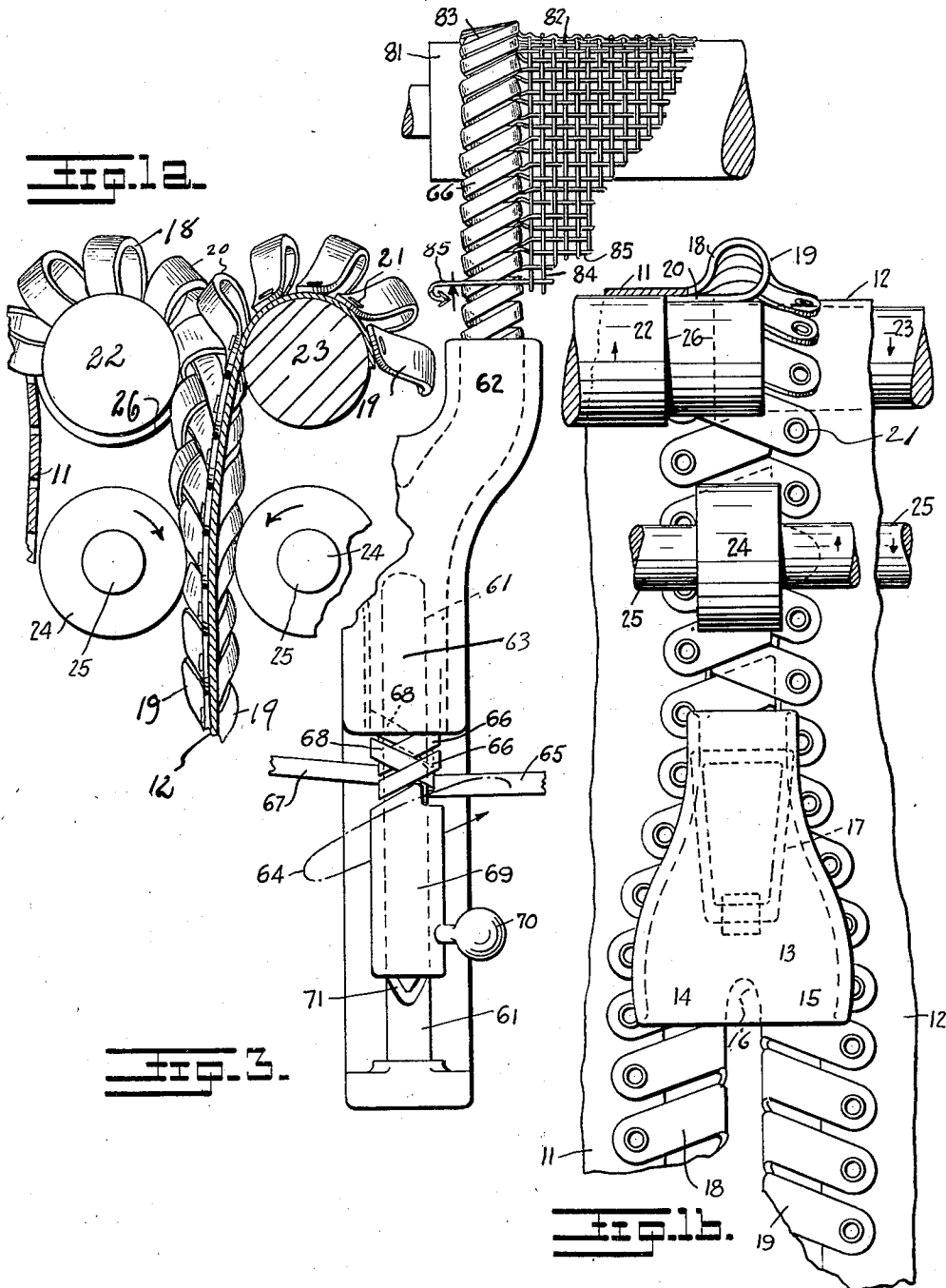

INVENTOR.  
NICOLAS WAHL.

BY *Neddy Waldman*  
ATTORNEY.

March 7, 1944.

N. WAHL

2,343,348

MAKING SEPARABLE FASTENERS

Filed Oct. 30, 1941

2 Sheets-Sheet 2

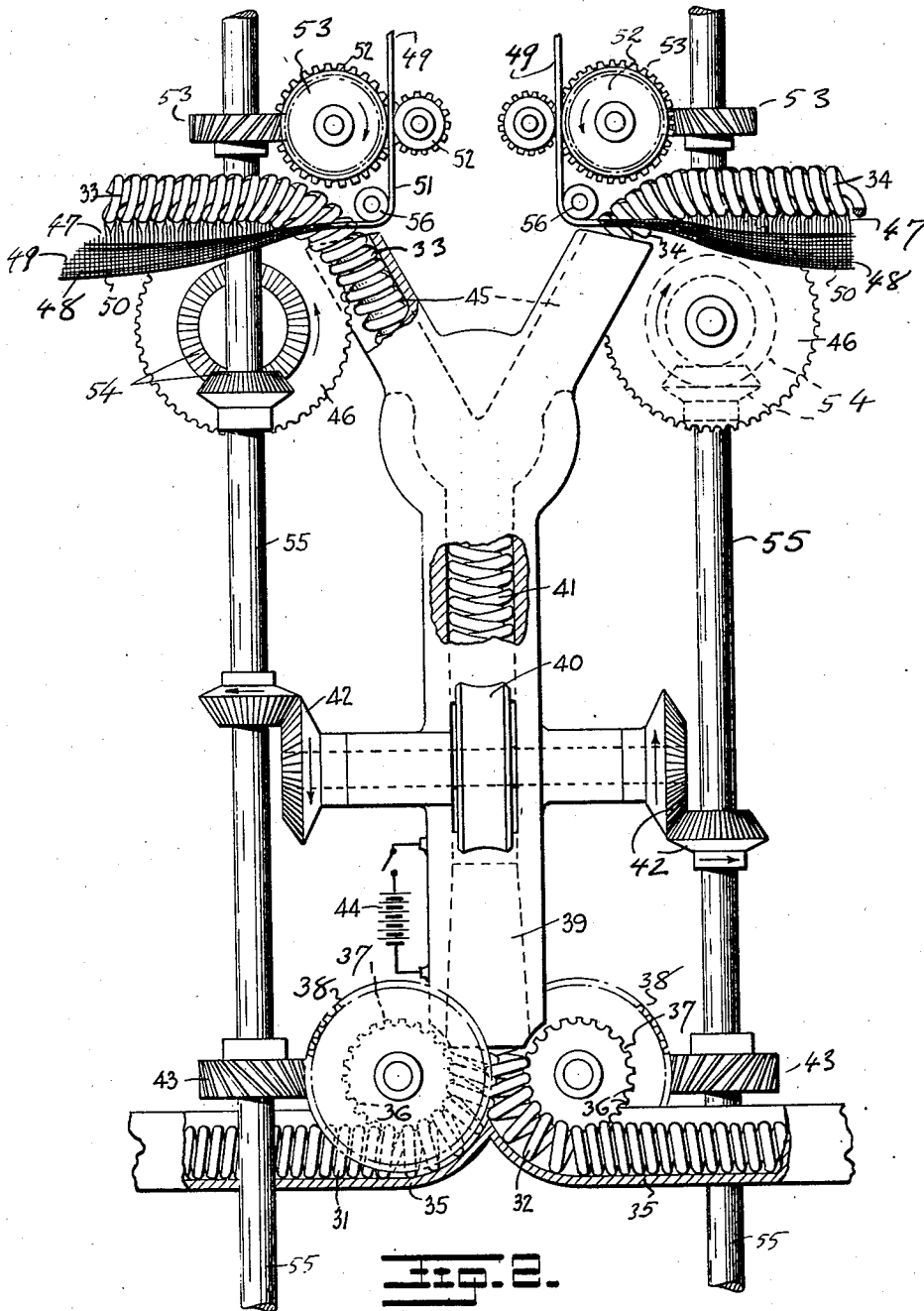

FIG. 2.

INVENTOR.  
NICOLAS WAHL.

BY *Rudolf W. ...*  
ATTORNEY

# UNITED STATES PATENT OFFICE

2,343,348

## MAKING SEPARABLE FASTENERS

Nicolas Wahl, New York, N. Y.

Application October 30, 1941, Serial No. 417,154

16 Claims. (Cl. 18—59)

This invention concerns the making of separable or slide fasteners. Such a fastener is a means for separably joining two edges and comprises a pair of stringers or rows of links aligned upon those edges and a slider adapted to be reciprocated upon those rows of links for the purpose of coupling and uncoupling them. The relative spacing of the links of a row being of import for the proper functioning of the device, the edge upon which they are aligned is ordinarily that of a special tape forming part of the fastener, and such tapes are applied to the edges of the goods to be coupled by the fastener.

In order to lock these two stringers upon each other in the coupled position, the prior art generally provided hooks upon the links of one row, which engage in eyes formed in the links of the other row. According to commercial standards such engagement between stringers in the coupled position is considered to be satisfactory if the stringers do not readily slip out of engagement from each other when subjected to a transverse pull. Such engagement, as normally required in a coupled fastener of the type herein concerned, is called and will hereinafter be identified as a "positive interlock."

From the standpoint of facilitating the making of the links and for other considerations it would be desirable to shape them as loops of a more or less flexible filament. As an example of a solution of this problem coils have been offered where each convolution of the coil served as a link. If the loops are rigid, or if in the case of coils the convolutions of at least one coil are locally reinforced or undercut to offer rigid hooks or eyes, their combination into a stringer-slider assembly may offer a "positive interlock," thus representing true fasteners. In that case, however, the filament cannot be of a uniform cross-section throughout, but it must be changed, e. g. reinforced at the point of the hook formation, or notched to offer an eye, or both. But without a change of the cross-section of the filament of flexible loops and of coils—to the extent to which these always have to be flexible for the purpose of slider control—a "positive interlock" could not heretofore be accomplished. I am aware, that any pair of fairly closely wound spring coils will lock upon each other, to a degree, when coupled in fastener fashion. In such instance, there will however never be a "positive interlock," but the degree of lock will depend upon the stiffness and resilience of the coils and upon friction between the coils. If the convolutions of one or both of a pair of coupled coils

are laterally bent or offset in order to present hooks to engage in the openings of the convolutions of the other coil, they will also interlock to a degree only, i. e. until the coupled coils are pulled apart by a force momentarily straightening out the bend or offset.

The accomplishment achieved within the scope of the prior art discussed above never took into consideration, that two rows of loops of filaments, the loops of each row being spaced apart to a distance less than the width of the filament in the direction of that respective row, might be nested or nestled within and around each other in such fashion that they offer a "positive interlock" but still are subject to control by a slider.

That idea of a separable or slide fastener, in which the rows of links are rows of filament loops and are nestled within each other in the coupled position so that they provide a "positive interlock," has been materialized by me in an invention which I first described in the United States and illustrated in particular reference to coil stringers in my parent application for Letters Patent Serial No. 304,701 of November 16, 1939, entitled Separable fastener.

This patent application is a continuation in part of said parent application and concerns the making of such fastener.

I have also discovered that the said idea may be applied to and exemplified in filaments by way of filament loops formed in a tape or in a portion of the goods from which they are to extend, such invention being laid down in my United States patent application Serial No. 378,611 of February 4, 1941, entitled Slider controlled fastener and method of making it, which is a companion application of the applications here discussed.

I have further determined, that the said idea may be incorporated in fasteners, in which the loops separately extend from or close upon an edge or tape, or extend through such edge or tape as rings. Such invention was laid down in my companion application for Letters Patent Serial No. 335,365 of May 15, 1940, entitled Separable fastener.

The various types of loops covered in the foregoing may be supplemented—to the extent to which this may be practical and will not derogate the unitary result of a nested or nestled fastener—by reinforcing edges which may even partly close a loop upon one side thereof as illustrated in Figures 9-11 of the last-mentioned companion application.

The instant invention of making fasteners is

equally applicable to devices of said parent application and of both the said companion applications. This application must therefore also rank as continuation in part of said companion applications.

Within the knowledge of the mechanical art the loops shown in the said applications, be they convolutions or coils, be they shaped in the margin or as the fringes of a material, or be they separate, may be prefabricated so that, as rows, they may be coupled by a slider and will then nest or nestle within each other. But I have found it to be useful and practical in most instances to couple such rows of loops during manufacture at an intermediate or final stage as a step in the making of the fastener, such steps being, for instance, complemented by steps for procuring alignment and an intimate nesting or nestling. In this connection it is of advantage, that the fasteners herein discussed are adapted for coupling from both ends, so that, for instance, in a continuous and progressive manufacturing procedure the rows of loops may be coupled for shaping, pressing and other steps of manufacture, and while progressing from that stage of manufacture they may be uncoupled again for purpose of being attached to a piece of goods or to a tape, etc.

The coupling of stringers, mounted or unmounted, during the manufacture, represents something new in the separable and slide fastener art. Coordinated with other manufacturing steps, which are facilitated by such combination, and also for reasons of simplified handling, of economy in general and of yielding a better product, such arrangement of manufacturing has been found to be quite useful and is the principal object of the instant patent application.

Other objects of this invention are easier to explain on the basis of a description of this invention, and will therefore be dwelled upon hereinafter.

It has also been found that many of the so-called separable or slide fasteners of the prior art which involve the use of loops but are not true fasteners, because there is no positive interlock, may be converted into fasteners in which the loops are nested or nestled within each other and are therefore positively interlocked. The means and ways to bring this about are another object of the instant invention.

In the following part of the specification and in the accompanying drawings the instant invention is described by way of various examples. Such description is to be interpreted in illustration of the invention, but not in limitation thereof.

In the drawings:

Fig. 1a shows a side view of an assembling arrangement for a pair of stringers which are for instance formed in the fringes of two pieces of goods, e. g. leather, one of said pieces being in cross-section.

Fig. 1b is a corresponding front view, including a slider applied to the finished goods. The other piece of goods is cross-sectioned in this instance.

Fig. 2 correspondingly illustrates a fastener manufacturing procedure starting with filament helices and tape.

Fig. 3 similarly shows a fastener manufacturing procedure starting with straight filaments and embodying the product as a selvaige into pieces of goods.

These illustrations are purely schematic.

Similar numerals refer to similar parts throughout the various views:

Fig. 1b shows two pieces of goods 11 and 12 which provide, more particularly where they extend below in a common place marginal portions adapted for control in separable fastener fashion by a slider 13.

Slider 13 couples or uncouples by being moved down or up, respectively, the stringers 18 and 19 provided on goods 11 and 12, respectively. A channel of said slider is customarily provided with bifurcations or branches 14 and 15, and the two halves of the slider 13, which complementarily accommodate the channel formation, are held together by a bow or bridge 16 extending across. Handle 17 serves for manipulation of slider 13.

Each of the stringers 18 and 19 comprises the rows of loops 20. These loops 20 are originally tongues or tabs which spacedly extend as fringes in the margins of goods 11 and 12, and are then suitably strapped back, e. g. by individual eyelets 21. The goods 11 and 12 are respectively hung onto revolvable beams 22 and 23, the latter beam being arranged behind the former, and the free ends of the beams slightly overlap each other. Between beams 22 and 23 the two pieces of goods depend in substantial alignment and are coupled below as first described. Underneath the beams 22 and 23 the meshing stringers 18 and 19 pass between two pressure rollers. The pressure rollers 24 may be adjustable towards and away from each other substantially in a direction normal to the plane of the drawing, so that the pressure applied by these rollers to stringers engaged therebetween may be regulated. Also with the knowledge of those versed in these arts these rollers 24 may be heated or there may be arrangements to heat the stringers between the beams and said rollers, said rollers being driven at like surface speed but in opposite directions. Beams 22 and 23 may be operatively connected with the rollers and similarly driven in opposite directions, but their effective surface speed may be slightly less than the surface speed of rollers 24.

Beam 22 is provided with a shoulder 26, against which may endwise abut the tips of the loops 20 of stringers 18. Beam 23 is shown to be tapered and to increase slightly in diameter towards its free end, at the left. Under the rule that "belts ride up" the goods 12 will therefore have a tendency to ride to the left on beam 23, so that the loops 20 of the respective stringer 19 will be pushed laterally to enter between the loops 20 of stringer 18, when the two rows of loops are fanned out in riding down over the beams 22 and 23.

If the goods 11 and 12 are fairly stiff foils subject to shaping under pressure, they may substantially retain the shape assumed when the loops 20 of the stringer 18 are pressed into intimate engagement with and nestle within the loops 20 of the other stringer 19 in passing between and in being compressed by the pressure rollers 24 and 25.

If the material of the pieces of goods 11 and 12 is shapeable at an elevated temperature but stiffens upon cooling, the stringers 18 and 19 may be raised to such temperature before entering between the rollers 24.

If the material of the stringers retains, after shaping, the very outline to which it is compressed, it may be preferable to use pressure roller 24 having a surface conforming to the ultimate shape of the filament loops of the stringers desired. A pressure roller having a concave surface for such purpose is for instance illustrated in Fig. 2.

If the pressure is to be applied under heat the rollers 24 themselves may be heated in usual ways,

e. g. by steam. We may, for instance, impregnate or size a material which lacks the stiffness and resiliency desired for the stringers, such as textiles, paper, leather, etc., with a solution which upon drying by heated rollers 24 leaves such material stiff and resilient. In case the inherent softness or limpness of the material is not to be impaired except at the fastener edge, the impregnating or sizing may be limited to such edge, e. g. by dipping only the loops 20 of the materials 11 and 12 into the stiffening solution or spraying them with such solution, before said goods pass through the apparatus indicated in Fig. 1.

After passing over the top of the beams 22 and 23 the loops 20 of the goods 11 and 12 will gape apart where they furthest project from said beams and while passing through a quadrant from the top position of the goods on the beams to a coupled position, so that the loops of the two materials enter between each other into a position of mesh in which they are pressed into nestling engagement while passing between rollers 24. The shape thus imparted to the loops should thereafter be resiliently preserved.

In the finished fastener shown at the bottom of Fig. 1 the loops extend at an incline from the respective pieces of goods, the incline being in the same direction in connection with both pieces of goods. In respect to the stringers the two pieces of goods are therefore not alike but are substantially symmetrical. It was mentioned above, that the tongues or fringes preferably extend originally at angles from the pieces of goods, so that the loops extend, even before shaping at the said incline from the goods. When they are so arranged, very little shaping is necessary in the pressure process. Each loop is merely to assume during pressure a shape, in which it gapes enough upon one side to receive a loop of the other stringer when the stringers are coupled and nestled by a slider. Upon its other side each loop will of course be adapted to enter upon a loop of the other stringer.

On the other hand it will be observed that even if the loops originally extend from the sides of the goods substantially normally to the edge thereof, they will, under due pressure effected by rollers 24, tilt into and nest in a position of positive interlock.

Under these circumstances it will be understood, that in connection with arrangements of the prior art where loops extend in a substantial normal direction from the goods and are wedged between each other in a quasi-locking position, the coupling may be converted into a positive interlock when the coupled loops are pressed into nestling engagement, in which case they assume the inclined position referred to.

This is illustrated in Fig. 2, where we start for purposes of an example, with half round filaments wound into two helices 31 and 32. These helices are wound in opposite directions and are eventually converted into coils having convolutions 33 and 34. Those convolutions are tilted and otherwise shaped for a nestling interlock when coupled.

The helices 31 and 32, which are close-wound or fairly closely wound from a suitable filament material arrive at the apparatus indicated in Fig. 2 from opposite directions, being, for instance, guided by channelling 35. Upon their arrival the helices 31 and 32 are engaged upon one of their sides by notches 36 cut at distances corresponding to the lead of the helices into the surfaces of wheels 37. Intermeshed helical gears 38 drive

the wheels 37 at like speeds in opposite direction. The like wheels 37 should be relatively angularly displaced to the distance of half the circular pitch of notches 36. Helices 31 and 32 are swung through a quadrant into substantial parallelism with each other while being carried along by the wheels 37. During this travel their convolutions gape apart upon the side opposite to where they are engaged upon wheels 37 so that, while passing through such quadrant, they will enter between each other and will be coupled in mesh with each other while travelling up into tubing 39. If the helices 31 and 32 have not been reduced to the desired overlap when pushed into each other while passing around wheel 37, they may be forced into such overlap while travelling up in tubing 39, such tubing being shown for such purpose to narrow down on opposite sides in the direction of upward travel of the coupled helices.

Eventually the coupled helices enter between and are compressed by a pair of pressure rollers 40. These rollers are mounted to extend from opposite sides into tubing 39 and are driven in opposite direction at like speed. The helices emerge from such rollers—as shown at 41 where the material of tubing 29 is cut away—in nestling engagement with each other, tilted and coupled in positive interlock suitable for separable or slide fasteners.

The pair of pressure rollers 40 are gearedly interconnected and, in the manner of rolling mills, their relative distance may be adjusted. They are shown to be operatively connected with the wheels 37, e. g. by a chain of bevel or helical gears 42 and 43, engaging by the latter upon the helical gears 38.

The arrangement and drive of the mechanism of Fig. 2 may be substantially symmetrical in respect to the center line of tubing 39.

Before entering between the pressure rollers 40 the coupled helices 31 and 32 should at least overlap each other to half their diameter, but they may overlap to an extent such as to be latterly offset from one another only by the thickness of the filament. The coupled helices may be heated, if they are easier to shape in a heated state, before they enter between rollers 40, the drawings indicating electric heating circuit 44 for such purpose, a suitable electric heating coil being, for instance, incorporated in the wall or tubing 39 in the known manner.

After the helices have been converted into coils having convolutions 33 and 34 and shown in an interlocked position at 41, they may be uncoupled in slide fastener fashion, the tubing 39 being shown to be bifurcated for such purpose at its upper end by way of branch channels 45. Thus the separated coil of convolutions 33 and 34 issue to the left and to the right, respectively, whereupon they are again engaged by suitable notched wheel 46 to be pulled away in opposite directions. Thereafter they may, continuing in their travel, be recoupled again and stored on reels. The notches of wheels 46 are spaced so that the respectively engaged portions and sides of convolutions 33 or 34 are close to each other. But such convolutions fan or gape apart upon their outwardly disposed sides in passing around said wheel 46, where they enter between the wefts 47 of a tape 49, where said tape does not have any warp thread. The warp portions 48 extend only on opposite sides of said tape.

The tape 51 extends for such purpose at a slant from a guide pulley 56 across the coil of gaping convolutions 33. It is suitably pulled away to-

gether with the convolutions 33 hooked between the wefts thereof, after the warp portions of such tape indicated at 50 have been folded under and together. These folded together portions may be subsequently united, e. g. by sewing. The stitches may be extended into the warpless portion and thereby into proximity with the convolutions 33, or the weft strands may there be tacked onto a ribbon there superimposed upon or inserted between the folded under sides of the tape in order to offer a shorter grip upon the coils hooked into the tape.

Tape 51 is shown to be delivered by suitable feed rollers 52 and the drive of such feed rolls may operatively connect to the other drives as indicated by spiral and bevel gearing 53 and 54 connecting with wheel 46. Thus the coil and tape may be coordinated in respect to their linear speed. The said gearing 53 and 54 may also connect to the gearing 38, 42, 43 controlling wheel 37 and pressure roller or rollers 40, such connection being offered in the schematic view of the drawing by the shaft 55. That shaft or a corresponding shaft coupled therewith and located upon the symmetrical other side of the arrangement is suitably connected to a source of power.

The number of convolutions of the helices 31 and 32 and of the coils, into which said helices are ultimately converted, accommodated between wheels 37 and 46 determine in part the pressure to which the coupled convolutions are subjected in passing between the pressure rollers 40. Care should be taken in adjusting the diameter of wheel 46 and the circular arrangement of notches therein that the fanned or gaping outsides of the convolutions enter between the wefts 47 at such distance from each other along the extent of the tape 51, as corresponds to the desired, close spacing of the convolutions in the finished fastener. Fig. 3 serves to illustrate, by way of modification,

a. That a pair of filaments may be folded for the instant purposes in a quasi-braiding position directly into a coupled position of the loops,

b. That the loops may be nestled by endwise pressure, whereas Fig. 1 illustrated pressure from opposite sides, and Fig. 2 illustrated pressure from opposite sides aided by endwise pressure, and

c. How a row of loops may be incorporated as a selvage in goods which are being woven.

It is of course understood that the embodiments shown in the three figures herein are not mutually exclusive, but that, within the knowledge of those acquainted with the respective arts, the improvements shown in one or the other of said figures, may also be applied or exploited in connection with the arrangement of another embodiment.

In order to simplify the understanding of the arrangements shown in Fig. 3, the operation there contemplated are indicated as manual operations it being, of course, understood that a person experienced in these arts may apply to the principles illustrated, the various braiding machines or looms available for such purpose, in continuous and automatic manufacturing operations.

Fig. 3 shows an arbor or mandrel 61 to be aligned with the main channel of a housing 62, such housing opening at its upper end by way of two branches delivering the disengaged coils for further operations, e. g. to be woven as selvages into goods. For the purpose of uncoupling the coils housing 62 corresponds generally to the conventional slider arrangement, except that the

main channel portion 63 is shown to be longer, in order to offer a space in which filaments which have been heated or impregnated before shaping or which are subject to curing by heat, may be cooled, dried, or baked, respectively, so that they are set in their final shape when the loops are uncoupled.

Arrow 64 indicates the motion by which a flat filament 65, being for instance contained on a web or spool of such filament, has been revolved once around the arbor 61, thus forming the loop 66 thereon. The other flat filament 67 had previously been correspondingly revolved around arbor 61, but in an opposite direction. By repetition of such alternating operations a number of loops 66 and 68 have been folded, partially on top of each other.

At suitable intervals the loops are advanced and slid off the mandrel which serves, at the same time, the purpose of pushing the loops into the closely nested formation desirable for separable or slide fastener use. The drawings indicate means suitable for bringing about the advancing and pushing each time a loop has been formed. For such purpose a sleeve 69 with handle 70 is reciprocally arranged upon the arbor 61. If the front end of sleeve 69 is to conform to the angle at which a convolution is to be pressed, it may be rotated between reciprocations in order then to present, at another angle, a similar surface for pushing a convolution of the other filament. The drawings show a V-shaped cam groove 71 to be provided in arbor 61, the inner end of handle 70 being engaged in such grooves, so that in being reciprocated the sleeve 69 may also be oscillated to arrive at the ends of alternate forward movements, in positions suitable for either pushing against a loop 66, or a loop 68.

The loops thus formed and nestled advance in the housing 62, from which they issue separately in order then to be mounted upon pieces of goods, e. g. tapes. The drawings show a coil thus formed to pass onto the beam 81 of a loom, upon which it advances, during rotation of said beam 81, together with the woven goods 82. Said coil 83 is shown to extend, as an end warp alongside of the other warp 84 and is controlled like the other warp to form sheds through which the shuttle is passed. A weft 85 will, as indicated by the arrow at the end thereof, return around coil 83 and will fall between convolutions of said coil, thus binding said coil as selvage into the woven goods.

After the weft has been moved back to the left over and forth underneath the row of loops 66, the incline of the loops will serve to advance the loop of the weft as it is pulled in between two convolutions of the coil, thus compensating for the advance of the weft caused in respect to the remainder of the goods being woven in the customary manner, e. g. by a reed.

Or if, as hereinafter discussed, a helix is to be woven as a selvage into goods and is subsequently only to be shaped for a nestling, positive interlock, the weaving operation may be so timed, that the weft is laid in immediately after it has been shot to the left, so that it will then be pulled in between the proper pair of convolutions of the helix, when the weft is shot in return to the right, thus weaving the helix as a selvage.

Inertia and friction of the advancing coils will serve to furnish in the embodiment of Fig. 3 the reaction desired for causing the convolutions to be pushed into and nestle within each other. The pressure should never, under any conditions, be

such that the loops of one row dent or notch those of the other. The smoothness of the loops and coils and the absence of the sharp hooks normally for a positive interlock permits the wefts to slip right in between the convolution during the weaving operation or through the adjouré tape of the embodiment of Fig. 2.

There may, of course, in all instances shown herein be additional guide or brake rollers for the coupled stringers or rows of loops, more particularly since in a practical arrangement supplemented by various other details the arrangement may not be as compact as shown in the sketches of the drawings. On the other hand it may be unnecessary to provide in all instances channels of the type shown in Figs. 2 and 3, more particularly if these channels, which primarily serve to guide and hold together the coupled loops, are replaced or supplemented by rollers which offer the corresponding reaction while the coupled loops are travelling along or serve to prevent that the coupled loops, while being compressed, will unduly spread in directions normal to the direction in which pressure is applied thereto. Generally speaking, pressure may be applied topwise or endwise, as long as the loops are shaped to nestle closely.

Bearing in mind that in many instances the application of pressure will be accompanied by heat, thermosetting and other treatment steps, the shaping of the coupled coil is shown in Figs. 2 and 3 to precede an attachment of these coils to goods, because ordinarily it will not be desirable to subject such goods to such treatments.

On the other hand a party versed in the respective art may readily reverse this order of procedure, if so desired, i. e. the loops may be coupled and compressed so as to tilt and nestle, after they have been attached to the goods. As a matter of fact this mode of procedure may be necessary, if the loops are not the convolutions of coils. It is unavoidable in the embodiment of Fig. 1, where the loops integrally extend from the material in which they are shaped. Likewise loops which are independent from each other, e. g. are rings, must first be arrayed in a row upon goods, before it is possible to couple such rows and subject them to the desired pressure.

Thus it may be easier to weave helices of the order illustrated at 31 and 32 in Fig. 2, when they are executed in brass, as a selvage into goods in the manner suggested at the top of Fig. 3, so that such helices are only afterwards reshaped by pressure to nestle in positive interlock. Or it may prove to be more practical, e. g. if such helices are extremely small, for purposes of handling these helices, to apply pressure thereto in a coupled position, after they have been mounted first. Under these considerations coils may be first mounted upon or incorporated in tapes or pieces of goods, then a pair of such stringers is brought into intermesh, and finally a nestling positive interlock is procured by the application of pressure.

If the loops are thus mounted before final shaping, the tapes upon which they are mounted will prevent them from spreading endwise. For instance, in the arrangement of Fig. 1, the coupled coils do not have to be constrained endwise while passing through the pressure rolls.

Having thus described my invention in detail, yet I do not wish to be limited thereby, except as the state of the art and the appended claims may require, for it is obvious that various modifications and changes may be made in the form

of embodiment of my invention, without departing from the spirit and scope thereof.

What I claim is:

1. The method for making a pair of rows of links which are positively interlocked in slide fastener fashion, comprising making a pair of rows of interconnected filament loops composed of a material which can be set to have such loops assume the natural form into which they are pressed, placing a loop of one row upon a loop of the other row and a loop of the other row upon a loop of the one row so that the free sides of the rows overlap each other from the respectively interconnected sides of the loops, shaping the loops by successively applying to the overlapping loops pressure pushing the free side of each loop into a loop of the other row while the interconnected side thereof is less distant from an adjacent loop of the respective row than it is wide in the direction of that row, and causing the loops to set and assume as their natural form the shape into which they are pressed.

2. The method for making a pair of rows of links which are positively interlocked in slide fastener fashion, comprising making a pair of rows of interconnected filament loops composed of a material which can be set to have such loops assume the natural form into which they are pressed, alternately placing a loop of one row upon a loop of the other row and a loop of the other row upon a loop of the one row so that the free sides of the rows overlap each other from the respectively interconnected sides of the loops, shaping the loops by applying to the overlapping loops normal to the direction in which they overlap pressure pushing the free side of each loop into a loop of the other row while the interconnected side thereof is less distant from an adjacent loop of the respective row than it is wide in the direction of that row, and causing the loops to set and assume as their natural form the shape into which they are pressed.

3. Making a pair of rows of links which are positively interlocked and adapted for uncoupling and coupling in slide fastener fashion, comprising oppositely winding a pair of coils in a filament of noncircular cross-section, said filament being composed of a material which can be set to have such coils assume the natural form into which they are pressed, spreading the convolutions of the coils apart on one of their sides and inserting the spread convolutions of one coil between the spread convolutions of the other one, shaping the interengaged coils so that the convolutions of one coil nestle within those of the other one by compressing them while interengaged, and causing the loops to set and assume as their natural form the shape into which they are pressed.

4. Making a pair of rows of links which are positively interlocked and adapted for uncoupling and coupling in slide fastener fashion, comprising oppositely winding a pair of helices in a filament of noncircular cross-section, said filament being composed of a material which can be set to have such helices assume the natural form into which they are pressed, spreading the convolutions of the helices apart on one of their sides and inserting the spread convolutions of one helix between the spread convolutions of the other one, shaping the interengaged helices so that the convolutions of one helix nestle within those of the other one by passing them through pressure rollers, and causing the loops to set and

assume as their natural form the shape into which they are pressed.

5. Applying a separable fastener, comprising making two coils of filament of noncircular cross-section, said filament being composed of a material which can be set to have such coils assume the natural form into which they are pressed, weaving them as selvage into goods, meshing the coils into each other, shaping the meshed coils by pressing the same against one another into a form adapted for uncoupling and coupling by a slider, and causing the loops to set and assume as their natural form the shape into which they are pressed.

6. Applying a separable fastener to goods, comprising attaching loops of filament of non-circular cross-section said filament being composed of a material which can be set to have such loops assume the natural form into which they are pressed, in rows to goods along two lines where the goods are to be coupled together, inserting the loops of one row of attached loops between those of the other row, shaping the rows thus inserted between each other by pressing the same against one another into a form adapted for uncoupling and coupling by a slider, and causing the loops to set and assume as their natural form the shape into which they are pressed.

7. Applying a separable fastener to goods, comprising stringing preshaped loops of a thermosetting plastic in rows upon goods along two lines where the goods are to be coupled together, inserting the loops of one row of attached loops between those of the other row, and thermosetting the rows thus inserted between each other by heat and pressure into a form adapted for uncoupling and coupling by a slider.

8. Applying a separable fastener to goods, comprising stringing loops of sheet materials which can be set to have such loops assume the natural form into which they are pressed, in close rows upon goods along two lines where the goods are to be coupled together, inserting the loops of one row of attached loops between those of the other row, and forcing the loops thus inserted between each other by pressure into a form wherein loops of one row extend within adjacent loops of the other row, and vice versa, and causing the loops to set and assume as their natural form the shape into which they are pressed.

9. The method of providing a pair of pieces of goods with separable fasteners permitting them to be coupled and uncoupled by a slider, comprising extending loops of filament of noncircular cross section from the edges of said pieces to be coupled, the loops on each piece being spaced apart less than they are wide and inserting between each other the loops extending from said pieces of goods and pressing them substantially flat while thus inserted, whereby the loops of each row are caused to extend within adjacent loops of the other row, and stiffening the loops to cause them to assume as their natural form the shape into which they are pressed.

10. The method of adapting two pieces of goods for coupling in slide fastener fashion, the material of said goods being capable of being set to assume the natural form into which they are pressed, comprising cutting strips in the marginal portions at which the two pieces of goods are to be coupled, fastening said stripped margins back onto the respective goods so that the strips form loops extending from said pieces, inserting between each other the loops extending from said pieces of goods and pressing them

substantially flat while thus inserted, and causing the loops to set and assume as their natural form the shape into which they are pressed.

11. The method of adapting two pieces of goods for coupling in slide fastener fashion comprising cutting strips in the marginal portions at which the two pieces of goods are to be coupled, fastening said stripped margins back onto the respective goods so that the strips form loops extending from said pieces, impregnating the loops with a stiffening composition, and coupling the pieces of goods by inserting the loops of one of said pieces into the loops of the other piece and the loops of the other piece into the loops of the one piece in which position they are allowed to stiffen.

12. The method of making pieces of goods adapted for coupling and uncoupling in slide fastener fashion comprising forming and inserting in each other a pair of coils of filament of noncircular cross section, said filament being composed of a material which can be set to have such coils assume the natural form into which they are pressed, so that the convolutions of one coil extend between the convolutions of the other one, shaping the coils by pressure so that the noncircular filament of each convolution of each coil, where inserted between other convolutions of the other coil, is tilted to extend into and nestle in one of those other convolutions, causing the loops to set and assume as their natural form the shape into which they are pressed, disengaging said coils from each other and weaving each coil as a selvage into goods being woven at a lead of the convolutions substantially corresponding to their lead after said nestling operation.

13. The method of shaping a pair of coils, composed of a material which can be set to have such coils assume the natural form in which they are pressed, for coupling and uncoupling in slide fastener fashion, comprising oppositely coiling two filaments of noncircular cross-section, each loop thus coiled extending around a portion of a loop of the coil of the other filament, setting the loops into the shape in which they have been coiled, and pushing the coils together so that the lead of each coil is less than twice the width of the respective filament.

14. Making rows of loops, composed of a material which can be set to have such loops assume the natural form in which they are pressed, coupled in slide fastener fashion, comprising alternately winding loops of two noncircular filaments in an opposite sense onto an arbor setting the loops into the shape in which they have been wound and forced to close formation by the application of a pushing force, and pushing them off said arbor in such close formation by such force, so that the loops of the two filaments nestle within the loops of the other filament, respectively, and thereafter separating the resultant coils from one another and attaching each coil along the edge of goods to be joined by the fastener.

15. The method of shaping a pair of coils, composed of a material which can be set to have such coils assume the natural form in which they are pressed, for coupling and uncoupling in slide fastener fashion, comprising oppositely coiling two filaments of non-circular cross-section, each loop thus coiled extending around a portion of a loop of the coil of the other filament, and setting the loops into the shape in which they have

been coiled with the lead of each coil less than twice the width of the respective filament.

16. Making rows of loops, composed of a material which can be set to have such loops assume the natural form in which they are pressed, coupled in slide fastener fashion, comprising alternately winding loops of two non-circular filaments in an opposite sense on to an arbor, setting the loops into the shape in which they have

been wound, pushing them off said arbor in such set condition of the loops with the loops of the two filaments nestled within the loops of the other filament, respectively, and thereafter separating the resultant coils from one another, and attaching each coil along the edge of goods to be joined by the fastener.

NICOLAS WAHL.