

(12) INTERNATIONAL APPLICATION PUBLISHED UNDER THE PATENT COOPERATION TREATY (PCT)

(19) World Intellectual Property
Organization
International Bureau



(43) International Publication Date
12 August 2004 (12.08.2004)

PCT

(10) International Publication Number
WO 2004/067906 A1

(51) International Patent Classification⁷: **E21B 33/14**

Michael, A.; 1906 Wagon Gap Trail, Houston, TX 77090 (US). JABS, Matthew, J.; 6969 Hollister, No. 1617, Houston, TX 77040 (US).

(21) International Application Number:
PCT/US2004/002327

(74) Agents: CARSON, Matt et al.; 3900 Essex Lane, Suite 1200, Houston, TX 77027 (US).

(22) International Filing Date: 28 January 2004 (28.01.2004)

(25) Filing Language: English

(81) Designated States (unless otherwise indicated, for every kind of national protection available): AE, AG, AL, AM, AT, AU, AZ, BA, BB, BG, BR, BW, BY, BZ, CA, CH, CN, CO, CR, CU, CZ, DE, DK, DM, DZ, EC, EE, EG, ES, FI, GB, GD, GE, GH, GM, HR, HU, ID, IL, IN, IS, JP, KE, KG, KP, KR, KZ, LC, LK, LR, LS, LT, LU, LV, MA, MD, MG, MK, MN, MW, MX, MZ, NA, NI, NO, NZ, OM, PG, PH, PL, PT, RO, RU, SC, SD, SE, SG, SK, SL, SY, TJ, TM, TN, TR, TT, TZ, UA, UG, US, UZ, VC, VN, YU, ZA, ZM, ZW.

(26) Publication Language: English

(30) Priority Data:
10/354,242 29 January 2003 (29.01.2003) US

(71) Applicant (for all designated States except US): BAKER HUGHES INCORPORATED [US/US]; 3900 Essex Lane, Suite 1200, Houston, TX 77027 (US).

(84) Designated States (unless otherwise indicated, for every kind of regional protection available): ARIPO (BW, GH, GM, KE, LS, MW, MZ, SD, SL, SZ, TZ, UG, ZM, ZW),

(72) Inventors: RICHARD, Bennett, M.; 4542 Windy Hollow Drive, Kingwood, TX 77345 (US). CARMODY,

[Continued on next page]

(54) Title: ALTERNATIVE METHOD TO CEMENTING CASING AND LINERS

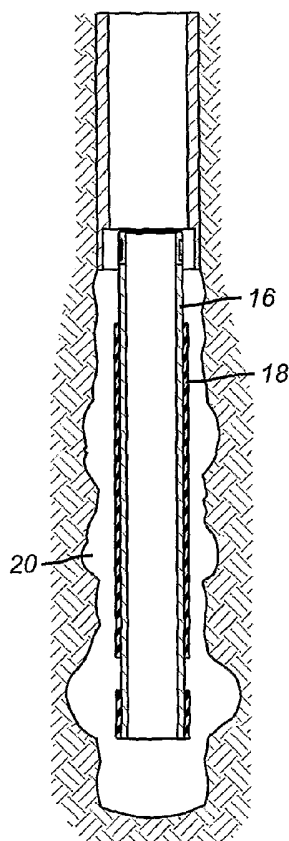

(57) Abstract: A method of sealing casing or liners in a wellbore is described. The stands of casing or liner (16) receive a jacket (18) bonded to the outer surface. Preferably, the jacket is a rubber compound bonded to the outer wall. The formulation responds to well fluids to swell at a predetermined rate. The casing or liner can also be expanded with a swage preferably prior to the onset of significant jacket swelling. Packers and sealing hangers can be optionally added at the extremes of the casing or liner string to further secure against channeling between adjacent formations.

WO 2004/067906 A1



Eurasian (AM, AZ, BY, KG, KZ, MD, RU, TJ, TM), European (AT, BE, BG, CH, CY, CZ, DE, DK, EE, ES, FI, FR, GB, GR, HU, IE, IT, LU, MC, NL, PT, RO, SE, SI, SK, TR), OAPI (BF, BJ, CF, CG, CI, CM, GA, GN, GQ, GW, ML, MR, NE, SN, TD, TG).

— *before the expiration of the time limit for amending the claims and to be republished in the event of receipt of amendments*

Published:

— *with international search report*

For two-letter codes and other abbreviations, refer to the "Guidance Notes on Codes and Abbreviations" appearing at the beginning of each regular issue of the PCT Gazette.

APPLICATION FOR PATENT

Inventors: Bennett M. Richard, Michael A Carmody, and Matthew J. Jabs

Title: Alternative Method to Cementing Casing and Liners

FIELD OF THE INVENTION

[0001] The field of this invention is methods designed to seal casing or liner in a wellbore using techniques involving a sealing material that swells downhole.

BACKGROUND OF THE INVENTION

[0002] Traditionally casing and liners have been sealed in the wellbore with cement that is pumped down internally and later displaced out the bottom of the casing or liner and into the annular space between the casing or liner and the wellbore. This procedure is expensive and requires the use of specialized equipment and specially trained personnel. The process is time consuming and the equipment takes up significant space such that in offshore platforms careful logistics are required to make room for the equipment when the cementing job is required. There are also uncertainties as to the distribution of the cement causing concerns of channeling of fluids from one zone penetrated by the casing or liner to an adjacent zone.

[0003] In the past, packers that seal tubing to casing using a ring that swells on contact with well fluids have been designed. These packers combined mechanical compression of the ring with the swelling property used to enhance the tightness of the seal. An example of such a packer is U.S. Patent 4,137,970. This patent describes various polymers, gels, and gels prepared from colloidal suspensions to take the place of mechanically compressed rubber to form a chemical seal ring. In water well applications, that generally are very shallow in comparison to a typical oil or gas well, jackets using grout sandwiched between flexible sheets have been wrapped around the casing and lowered into the water in the wellbore. When the water reached the grout, the grout expanded between the flexible sheets to seal the casing. The grout design is not workable for the fluids and temperatures typically seen in oil and gas wells. Additionally, there is a need to allow sufficient time in the swelling to allow time to properly place the casing or liner before significant swelling begins.

[0004] The present invention eliminates the cementing process completely. It provides for the stands of casing or liner to be wrapped between the end connections with a rubber sleeve preferably bonded to the tubular. When the string of casing or liner is run, the rubber slowly swells to seal around the casing or liner. Optionally, the casing or liner can be expanded with a swage to reduce the volume of the annular space around the casing or liner that the rubber sleeve would have to bridge. Optionally, a packer can be placed at the lower end of the casing or liner string and a sealing hanger can be used near the top of the casing or liner string. Different formulations for the sleeves can be used that are responsive to the presence of different fluids or that induce swelling at different rates, depending on the particulars of the installation. Those skilled in the art will further appreciate the scope of the claimed invention from a description of the preferred embodiment and the claims, which appear below.

SUMMARY OF THE INVENTION

[0005] A method of sealing casing or liners in a wellbore is described. The stands of casing or liner receive a jacket bonded to the outer surface. Preferably, the jacket is a rubber compound bonded to the outer wall. The formulation responds to well fluids to swell at a predetermined rate. The casing or liner can also be expanded with a swage preferably prior to the onset of significant jacket swelling. Packers and sealing hangers can be optionally added at the extremes of the casing or liner string to further secure against channeling between adjacent formations.

DETAILED DESCRIPTION OF THE DRAWINGS

[0006] Figure 1 is a section view of one length of casing or liner showing the jacket mounting in the detailed segment;

[0007] Figure 2 is an elevation view of the wellbore before liner insertion;

[0008] Figure 3 is the view of Figure 2 with the casing or liner run in;

[0009] Figure 4 is the view of Figure 3 showing the casing or liner being optionally expanded while the jacket is partially compliant; and

[0010] Figure 5 shows the casing or liner fully expanded and the rubber completely compliant.

DETAILED DESCRIPTION OF THE PREFERRED EMBODIMENT

[0011] Figure 1 shows a typical stand of casing or liner 16 in a much longer string that is to be inserted at a desired wellbore location. The wellbore 12 that has already been cased with casing 14 is shown in Figure 2. Figure 3 shows the stand of casing or liner 16 inserted into the wellbore and overlapping with casing 14. Depending on the dimensions of the wellbore and the covering 18, the annular space 20 between string 16 and wellbore 12 could be sealed by swelling of covering 18 without physical expansion of the string 16. Optionally, as shown in Figure 4, a swage, schematically illustrated as 22 can expand the string 16 before the covering has finished swelling and while voids such as 24 and 26 still exist. When the expansion is complete and the swelling stops, Figure 5 is the way the assembly will look. The string 16 is supported from casing 14 and fully expanded to approximately the same diameter. Alternatively or additionally, a packer or some other annular blocking device 28 can be placed at the lower end to keep the covering 18 from extruding. Additionally, a sealing type hanger apparatus 30 can be placed at the upper end of string 16 to support its weight and to counteract any tendency of the covering 18 to extrude, while swelling. Again, the string 16 can be supported from casing 14 with a hanger such as 30 or equivalent and the covering 18 be designed thick enough to swell and seal annular space 20. Alternatively, the upper end only of the string 16 may be expanded to make circumferential contact to attach it to casing 14 to eliminate use of the hanger 30 and to provide an extrusion barrier.

[0012] The covering 18 that can be placed on each joint of the string 16 can be selected to react to oil based mud, water based systems, or, hydrocarbon or salt water production. The swelling rate should be slow enough to allow the string 16 to be assembled and placed in the wellbore 12 at the proper location. The covering for hydrocarbon induced swelling is preferably made of a Nitrile Rubber compound supplied by PolyOne Corp., 150 So. Connell Ave., Dyersburg, Tn., 38024. A typical formulation might be Low CAN Butadiene Acrylonitrile 100, Zinc Oxide 5, Stearic Acid 0.50, Aminox 2, N550 Carbon Black 70, Di-Octyl Sebacate 7.5, Spider Sulfur, 0.50, Vulkacit DM 1, Vulkacit Thiuram 1.25, TETD 1.25. and is preferably bonded

to the outer wall of each joint of the string **16**. Preferably, when bonded it is a single annular shape with no seams that can allow channeling.

[0013] The present invention offers the advantages of easy deployment, prevention of channeling due to the bonded mounting of the covering **18**, prevention of premature cement setting inside the string, and use with conventional or expandable casing and liners.

[0014] The foregoing disclosure and description of the invention are illustrative and explanatory thereof, and various changes in the size, shape and materials, as well as in the details of the illustrated construction, may be made without departing from the spirit of the invention.

We claim:

1. A method of sealing a tubular string in a wellbore, comprising:
providing a seamless covering on a plurality of stands that make up the tubular string;
running the tubular string to a desired position in the wellbore;
using well fluids to promote swelling of said covering at a rate slow enough to allow placement of said string at the depth desired.
2. The method of claim 1, comprising:
bonding the covering to the stands.
3. The method of claim 1, comprising:
expanding the stands.
4. The method of claim 3, comprising:
performing said expanding before said covering swells completely.
5. The method of claim 1, comprising:
providing extrusion barriers for said covering near at least one extremity of said string; and
leaving the ends of said stands uncovered.
6. The method of claim 5, comprising:
providing a combination hanger and extrusion barrier for said covering near an upper end of said string.
7. The method of claim 1, comprising:
overlapping said string with existing well casing;
expanding an end of said string to support it from said existing well casing.
8. The method of claim 7, comprising:

providing substantially circumferential sealing contact between said string and said existing well casing due to said expansion;

using said sealing contact as an extrusion barrier.

9. The method of claim 1, comprising:

making said covering from a material that swells in the presence of one of oil based mud and oil based hydrocarbon production.

10. The method of claim 1, comprising:

making said covering from a material that swells in the presence of one of water based systems and water based production well fluids.

11. The method of claim 1, comprising:

allowing said covering to fill wellbore irregularities due to said swelling.

12. The method of claim 1, comprising:

making said covering from a polymer.

13. The method of claim 12, comprising:

making said covering from rubber.

14. The method of claim 2, comprising:

expanding the stands.

15. The method of claim 14, comprising:

performing said expanding before said covering swells completely.

16. The method of claim 15, comprising:

allowing said covering to fill wellbore irregularities due to said swelling.

17. The method of claim 16, comprising:

making said covering from a polymer.

18. The method of claim 17, comprising:

providing extrusion barriers for said covering near at least one extremity of said string.

19. The method of claim 18, comprising:

providing substantially circumferential sealing contact between said string and said existing well casing due to said expansion;

using said sealing contact as an extrusion barrier.

20. The method of claim 19, comprising:

making said covering from rubber.

+

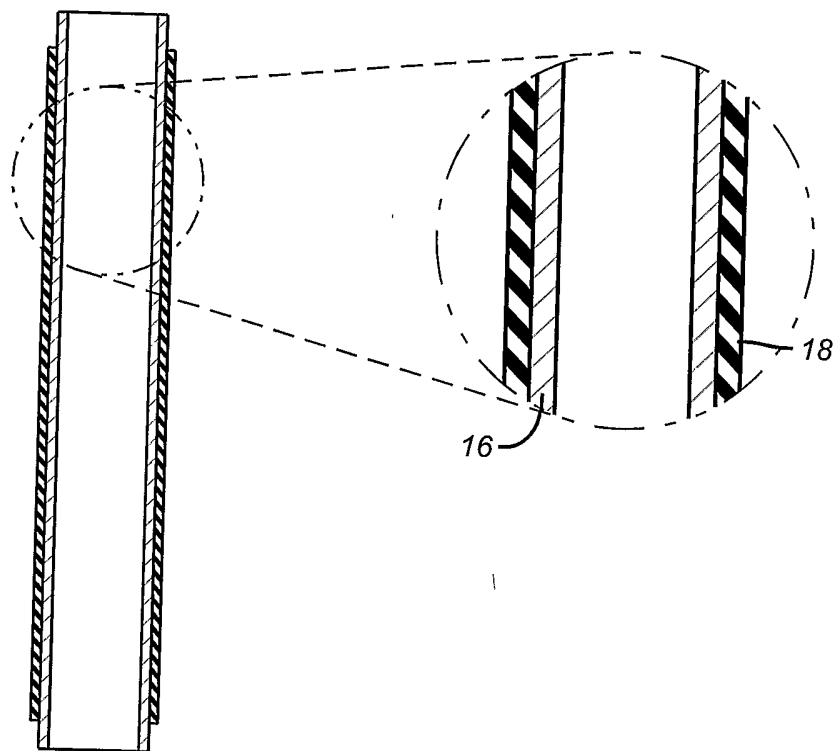

FIG. 1

+

+

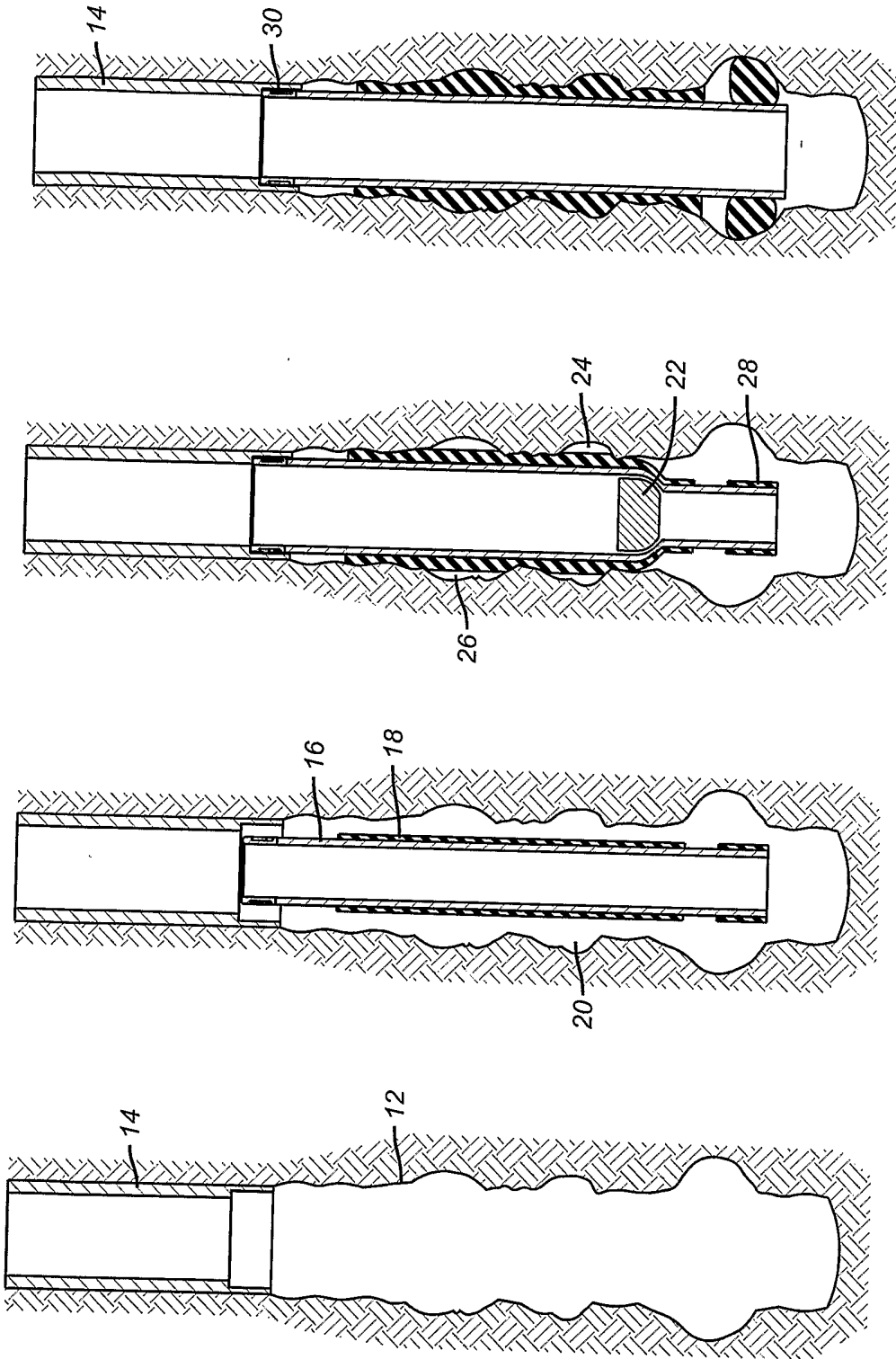

FIG. 5

FIG. 4

FIG. 3

FIG. 2

+

INTERNATIONAL SEARCH REPORT

International Application No
PCT/US2004/002327

A. CLASSIFICATION OF SUBJECT MATTER
IPC 7 E21B33/14

According to International Patent Classification (IPC) or to both national classification and IPC

B. FIELDS SEARCHED

Minimum documentation searched (classification system followed by classification symbols)
IPC 7 E21B

Documentation searched other than minimum documentation to the extent that such documents are included in the fields searched

Electronic data base consulted during the international search (name of data base and, where practical, search terms used)

EPO-Internal

C. DOCUMENTS CONSIDERED TO BE RELEVANT

Category °	Citation of document, with indication, where appropriate, of the relevant passages	Relevant to claim No.
X	US 3 385 367 A (PAUL KOLLSMAN) 28 May 1968 (1968-05-28) The subject-matter of claims 3-4, 7-8, 14-20 are considered obvious w.r.t. this document alone. column 11, line 8 - line 38; figure 1 ---	1-20
X	US 5 195 583 A (BELSHAW DOUGLAS J ET AL) 23 March 1993 (1993-03-23) column 5, line 9 - line 23; figure 1 ---	1
X	US 2 945 541 A (MALY GEORGE P ET AL) 19 July 1960 (1960-07-19) column 2, line 17 - line 32; figure 3 ---	1
A	US 4 936 386 A (COLANGELO ROBERT V) 26 June 1990 (1990-06-26) figures 1,2 ---	1
-/--		

Further documents are listed in the continuation of box C.

Patent family members are listed in annex.

° Special categories of cited documents :

- "A" document defining the general state of the art which is not considered to be of particular relevance
- "E" earlier document but published on or after the international filing date
- "L" document which may throw doubts on priority claim(s) or which is cited to establish the publication date of another citation or other special reason (as specified)
- "O" document referring to an oral disclosure, use, exhibition or other means
- "P" document published prior to the international filing date but later than the priority date claimed

- "T" later document published after the international filing date or priority date and not in conflict with the application but cited to understand the principle or theory underlying the invention
- "X" document of particular relevance; the claimed invention cannot be considered novel or cannot be considered to involve an inventive step when the document is taken alone
- "Y" document of particular relevance; the claimed invention cannot be considered to involve an inventive step when the document is combined with one or more other such documents, such combination being obvious to a person skilled in the art.
- "&" document member of the same patent family

Date of the actual completion of the international search 6 July 2004	Date of mailing of the international search report 13/07/2004
Name and mailing address of the ISA European Patent Office, P.B. 5818 Patentlaan 2 NL - 2280 HV Rijswijk Tel. (+31-70) 340-2040, Tx. 31 651 epo nl, Fax: (+31-70) 340-3016	Authorized officer Stroemmen, H.

INTERNATIONAL SEARCH REPORT

International Application No
PCT/US2004/002327

C.(Continuation) DOCUMENTS CONSIDERED TO BE RELEVANT

Category *	Citation of document, with indication, where appropriate, of the relevant passages	Relevant to claim No.
X,P	US 2003/075333 A1 (VERCAEMER CLAUDE ET AL) 24 April 2003 (2003-04-24) paragraphs '0040!', '0058!; figure 17 -----	1-20

INTERNATIONAL SEARCH REPORT

International Application No
PCT/US2004/002327

Patent document cited in search report	A	Publication date	Patent family member(s)	Publication date
US 3385367	A	28-05-1968	NONE	
US 5195583	A	23-03-1993	GB 2248255 A CA 2052308 A1	01-04-1992 28-03-1992
US 2945541	A	19-07-1960	NONE	
US 4936386	A	26-06-1990	US 4919989 A	24-04-1990
US 2003075333	A1	24-04-2003	US 2003075323 A1 BR 0203991 A CA 2406490 A1 GB 2381021 A ,B NO 20025051 A	24-04-2003 16-09-2003 22-04-2003 23-04-2003 23-04-2003