



(12) **EUROPEAN PATENT APPLICATION**

(88) Date of publication A3:
13.07.2005 Bulletin 2005/28

(51) Int Cl.7: **C14C 15/00**

(43) Date of publication A2:
19.05.2004 Bulletin 2004/21

(21) Application number: **03024984.1**

(22) Date of filing: **30.10.2003**

(84) Designated Contracting States:
**AT BE BG CH CY CZ DE DK EE ES FI FR GB GR
HU IE IT LI LU MC NL PT RO SE SI SK TR**
Designated Extension States:
AL LT LV MK

(72) Inventor: **Serrini, Mario**
56024 San Miniato (IT)

(74) Representative:
Gritschneider, Martin, Dipl.-Phys. et al
Patentanwälte Abitz & Partner
Postfach 86 01 09
81628 München (DE)

(30) Priority: **04.11.2002 IT PI20020063**

(71) Applicant: **Italprogetti Engineering S.R.L.**
San Romano, 56020 Montopoli V.A. (IT)

(54) **Drum with improved structure for processing leather or similars**

(57) In a drum (10) for processing leather or similar, a partial or total covering of the metallic cylindrical surface (11) is provided, by means of pressed sheet metal (19), and in particular embossed sheet metal, fixed to said surface (11) by welding executed both along the perimeter and in internal points of the sheet metal. The

interstice that takes shape between the cylindrical surface (11) of the drum and the covering sheet metal (19) has a small volume, useful to allow the speeding up of the heating and cooling phases of the drum. A structural enforcement of the cylindrical surface of the drum and a simplification in the creating of the interstice are also obtained through the above covering.

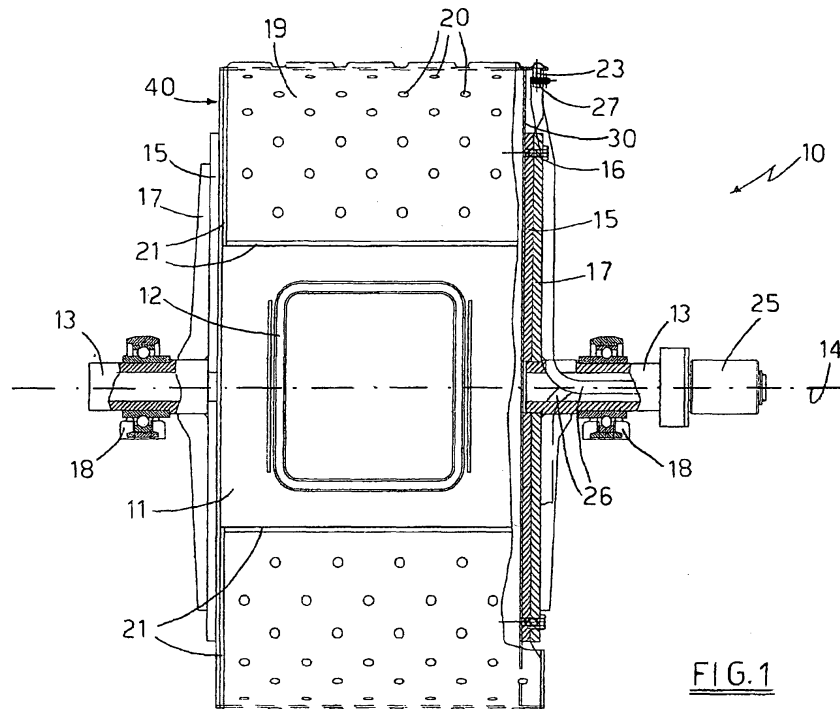

FIG.1



DOCUMENTS CONSIDERED TO BE RELEVANT			
Category	Citation of document with indication, where appropriate, of relevant passages	Relevant to claim	CLASSIFICATION OF THE APPLICATION (Int.Cl.7)
A	DE 80 757 C (EDUARD WEYERS) 5 September 1894 (1894-09-05) * the whole document * -----	1,4,5	C14C15/00
			TECHNICAL FIELDS SEARCHED (Int.Cl.7)
			C14C
The present search report has been drawn up for all claims			
Place of search The Hague		Date of completion of the search 23 May 2005	Examiner De Rijck, F
<p>CATEGORY OF CITED DOCUMENTS</p> <p>X : particularly relevant if taken alone Y : particularly relevant if combined with another document of the same category A : technological background O : non-written disclosure P : intermediate document</p> <p>T : theory or principle underlying the invention E : earlier patent document, but published on, or after the filing date D : document cited in the application L : document cited for other reasons & : member of the same patent family, corresponding document</p>			

1
EPO FORM 1503 03/02 (P04C01)

**ANNEX TO THE EUROPEAN SEARCH REPORT
ON EUROPEAN PATENT APPLICATION NO.**

EP 03 02 4984

This annex lists the patent family members relating to the patent documents cited in the above-mentioned European search report. The members are as contained in the European Patent Office EDP file on
The European Patent Office is in no way liable for these particulars which are merely given for the purpose of information.

23-05-2005

Patent document cited in search report	Publication date	Patent family member(s)	Publication date
DE 80757	C	NONE	

EPO FORM P0459

For more details about this annex : see Official Journal of the European Patent Office, No. 12/82