



US00RE46107E

(19) **United States**
(12) **Reissued Patent**
Swei et al.

(10) **Patent Number:** **US RE46,107 E**
(45) **Date of Reissued Patent:** **Aug. 16, 2016**

(54) **INTEGRATED CIRCUITS INCLUDING A CHARGE PUMP CIRCUIT AND OPERATING METHODS THEREOF**

(71) Applicant: **TAIWAN SEMICONDUCTOR MANUFACTURING COMPANY, LTD.**, Hsinchu (TW)
(72) Inventors: **Steven Swei**, Fremont, CA (US); **Chih-Chang Lin**, San Jose, CA (US); **Tien-Chun Yang**, San Jose, CA (US); **Chan-Hong Chern**, Palo Alto, CA (US); **Ming-Chieh Huang**, San Jose, CA (US)
(73) Assignee: **TAIWAN SEMICONDUCTOR MANUFACTURING COMPANY, LTD.** (TW)

(21) Appl. No.: **14/284,181**
(22) Filed: **May 21, 2014**

Related U.S. Patent Documents

Reissue of:
(64) Patent No.: **8,183,913**
Issued: **May 22, 2012**
Appl. No.: **12/706,886**
Filed: **Feb. 17, 2010**

(51) **Int. Cl.**
G05F 1/10 (2006.01)
G05F 3/02 (2006.01)
(52) **U.S. Cl.**
CPC **G05F 1/10** (2013.01); **G05F 3/02** (2013.01)
(58) **Field of Classification Search**
CPC **G05F 1/10**; **G05F 3/02**
USPC **327/144-163, 535-537; 375/373-376; 331/15-17**

See application file for complete search history.

(56) **References Cited**

U.S. PATENT DOCUMENTS

| | | | | |
|--------------|------|---------|---------------|---------|
| 6,124,755 | A * | 9/2000 | Parker et al. | 327/543 |
| 6,603,348 | B1 * | 8/2003 | Preuss et al. | 327/563 |
| 6,853,253 | B2 * | 2/2005 | Desortiaux | 331/16 |
| 7,256,631 | B2 * | 8/2007 | Kim | 327/157 |
| 7,418,071 | B2 * | 8/2008 | Harrison | 375/374 |
| 7,570,105 | B1 * | 8/2009 | Baek et al. | 327/536 |
| 7,812,652 | B2 * | 10/2010 | Mei | 327/156 |
| 2005/0195003 | A1 * | 9/2005 | Soe | 327/157 |
| 2005/0237092 | A1 * | 10/2005 | Kawago et al. | 327/157 |

OTHER PUBLICATIONS

Loke, Alvin L. S., et al., "A Versatile 90-nm CMOS Charge-Pump PLL for SerDes Transmitter Clocking", IEEE Journal of Solid-State Circuits, vol. 41, No. 8, Aug. 2006, pp. 1894-1907.

* cited by examiner

Primary Examiner — My-Trang Ton

(74) *Attorney, Agent, or Firm* — Hauptman Ham, LLP

(57) **ABSTRACT**

An integrated circuit includes a first current source. A second current source is electrically coupled with the first current source via a conductive line. A switch circuit is coupled between the first current source and the second current source. A first circuit is coupled between a first node and a second node. The first node is disposed between the first current source and the switch circuit. The second node is coupled with the first current source. The first circuit is configured for substantially equalizing voltages on the first node and the second node. A second circuit is coupled between a third node and a fourth node. The third node is disposed between the second current source and the switch circuit. The fourth node is disposed coupled with the second current source. The second circuit is configured for substantially equalizing voltages on the third node and the fourth node.

18 Claims, 4 Drawing Sheets

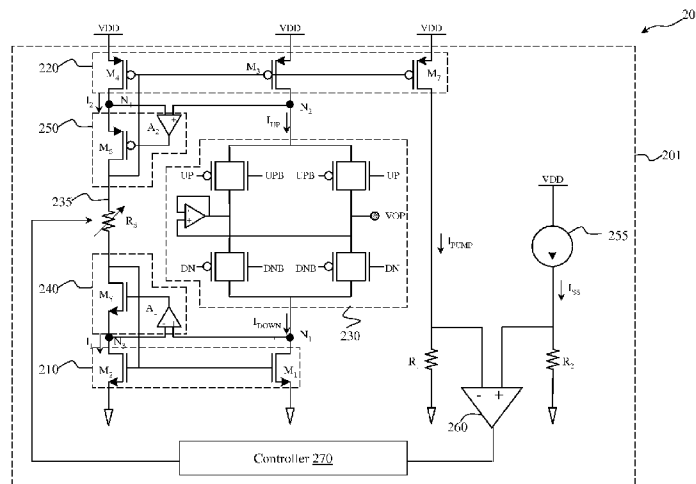

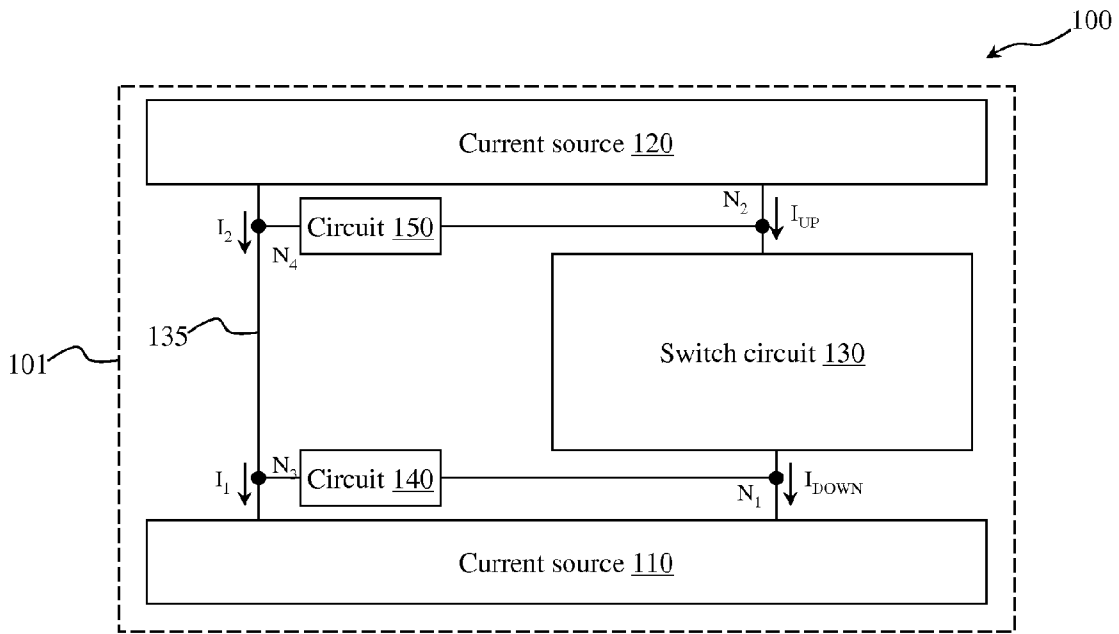

FIG. 1

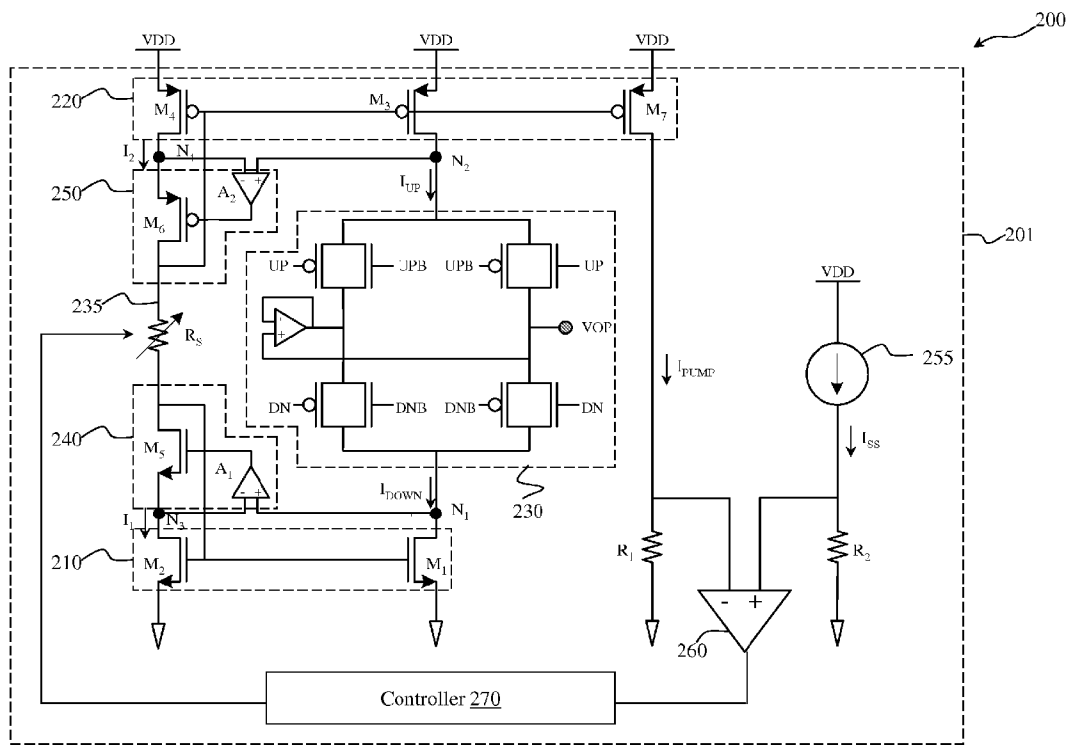

FIG. 2

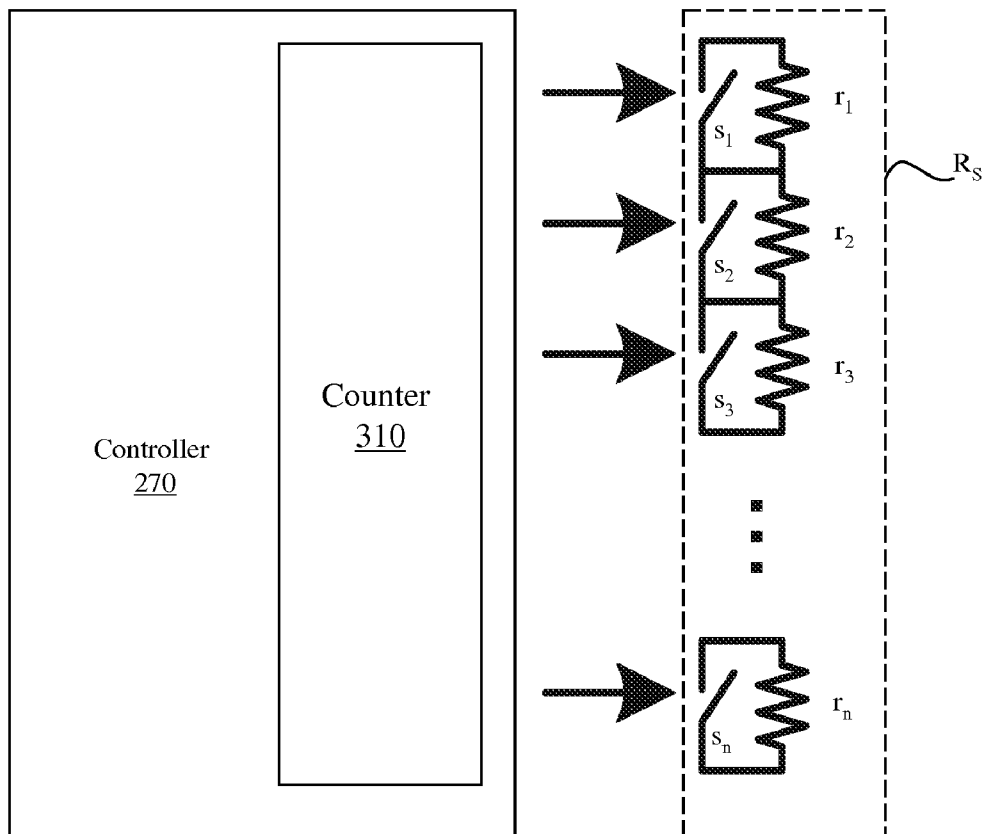

FIG. 3

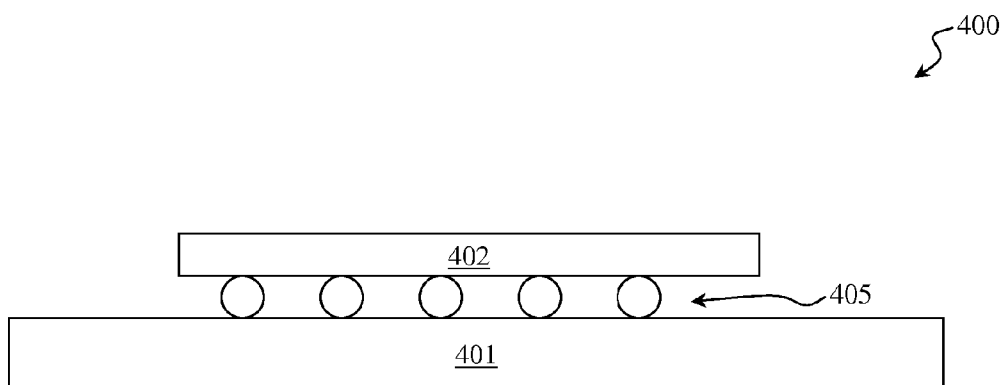

FIG. 4

INTEGRATED CIRCUITS INCLUDING A CHARGE PUMP CIRCUIT AND OPERATING METHODS THEREOF

Matter enclosed in heavy brackets [] appears in the original patent but forms no part of this reissue specification; matter printed in italics indicates the additions made by reissue; a claim printed with strikethrough indicates that the claim was canceled, disclaimed, or held invalid by a prior post-patent action or proceeding.

RELATED APPLICATIONS

The present application is a reissue of U.S. patent application Ser. No. 12/706,886, filed Feb. 17, 2010, now U.S. Pat. No. 8,183,913, issued May 22, 2012, the content of which is hereby incorporated by reference herein in its entirety.

FIELD OF THE DISCLOSURE

The present disclosure relates generally to the field of semiconductor circuits, and more particularly, to integrated circuits including a charge pump circuit and operating methods thereof.

BACKGROUND OF THE DISCLOSURE

Phase-locked loops (PLLs) are widely used in electronic designs such as radios, television receivers, video apparatuses, satellite broadcasts, and instrumentation systems. PLLs are electronic circuits with a voltage-controlled oscillator (VCO) or a current-controlled oscillator (CCO) that is constantly driven to match the frequency of an input signal.

BRIEF DESCRIPTION OF THE DRAWINGS

The present disclosure is best understood from the following detailed description when read with the accompanying figures. It is emphasized that, in accordance with the standard practice in the industry, various features are not drawn to scale and are used for illustration purposes only. In fact, the numbers and dimensions of the various features may be arbitrarily increased or reduced for clarity of discussion.

FIG. 1 is a schematic drawing illustrating an exemplary integrated circuit including a charge pump circuit.

FIG. 2 is a schematic drawing illustrating another exemplary integrated circuit including an exemplary charge pump circuit.

FIG. 3 is a schematic drawing illustrating an exemplary controller coupled with an exemplary adjustable resistance circuit R_S .

FIG. 4 is a schematic drawing illustrating a system including an exemplary integrated circuit disposed over a substrate board.

DETAILED DESCRIPTION OF THE DISCLOSURE

A PLL circuit includes a charge pump circuit. The charge pump circuit is disposed between a phase frequency detector (PFD) and a voltage-controlled oscillator (VCO). The charge pump circuit receives signals from the PFD to charge or discharge a capacitor that is disposed on a node between the charge pump circuit and the VCO. A current supplied to charge the capacitor is referred to as an up current. Another current supplied to discharge the capacitor is referred to a

down current. By adjusting the up current and the down current, the operation of the PLL circuit can be locked.

The applicants found that the voltage on the output end of the charge pump circuit may shift up and down. The variation of the output voltage may result from channel-length modulation of the transistors. The applicants also found that the process of forming the transistors may cause transistor mismatch. Due to the transistor mismatch and/or the channel-length modulation, when the operation of the PLL circuit is locked, the up current is different from the down current. The difference between the up and down currents can result in reference spur, static phase error, and/or jitter at an output end of the PLL circuit.

Based on the foregoing, integrated circuits including a charge pump circuit and operating methods thereof are desired.

It is understood that the following disclosure provides many different embodiments, or examples, for implementing different features of the disclosure. Specific examples of components and arrangements are described below to simplify the present disclosure. These are, of course, merely examples and are not intended to be limiting. In addition, the present disclosure may repeat reference numerals and/or letters in the various examples. This repetition is for the purpose of simplicity and clarity and does not in itself dictate a relationship between the various embodiments and/or configurations discussed. Moreover, the formation of a feature on, connected to, and/or coupled to another feature in the present disclosure that follows may include embodiments in which the features are formed in direct contact, and may also include embodiments in which additional features may be formed interposing the features, such that the features may not be in direct contact. In addition, spatially relative terms, for example, “lower,” “upper,” “horizontal,” “vertical,” “above,” “below,” “up,” “down,” “top,” “bottom,” etc. as well as derivatives thereof (e.g., “horizontally,” “downwardly,” “upwardly,” etc.) are used for ease of the present disclosure of one features relationship to another feature. The spatially relative terms are intended to cover different orientations of the device including the features.

Embodiments of the present disclosure are directed to integrated circuits including a charge pump circuit and methods of operating the integrated circuit. By substantially equalizing the up current and the down current of the charge pump circuit, reference spur, static phase error, and/or jitter at an output end of the PLL circuit can be desirably reduced. Following are descriptions of exemplary embodiments regarding the integrated circuit and operating methods thereof. The scope of the present application is not limited thereto.

FIG. 1 is a schematic drawing illustrating an exemplary integrated circuit including a charge pump circuit. In FIG. 1, an integrated circuit **100** can include a charge pump circuit **101**. The integrated circuit **100** can be an analog phase-locked system, e.g., a phase-locked loop (PLL), a delay-locked loop (DLL), a clock and data recovery (CDR) circuit, or the like. In some embodiments, the charge pump circuit **101** can be disposed between a phase frequency detector (PFD) (not shown) and a voltage-controlled oscillator (VCO) (not shown). At least one capacitor can be coupled with a node that is disposed between the charge pump circuit **101** and the VCO. A current can flow from the charge pump circuit **101** to the capacitor to charge the capacitor or flow to the charge pump circuit **101** from the capacitor to discharge the capacitor.

In some embodiments, the charge pump circuit **101** can include current sources **110** and **120**. A switch circuit **130** can be electrically coupled between the current sources **110** and **120**. The current sources **110** and **120** can be electrically

coupled with each other via a conductive line **135**. A circuit **140** can be disposed between nodes N_1 and N_3 . A circuit **150** can be disposed between nodes N_2 and N_4 . The node N_1 can be disposed between the current source **110** and the switch circuit **130**. The node N_2 can be disposed between the current source **120** and the switch circuit **130**. The nodes N_3 and N_4 can be coupled with the current source **110** and **120**, respectively. The circuit **140** can be configured for substantially equalizing voltages on the nodes N_1 and N_3 . The circuit **150** can be configured for substantially equalizing voltages on the nodes N_2 and N_4 .

Referring to FIG. **1**, if the phase-locked system is locked, currents I_1 and I_2 can flow on the nodes N_3 and N_4 , respectively. Since the currents I_1 and I_2 are flowing on the same conductive line **135**, the current I_1 flowing on the node N_3 can be substantially equal to the current I_2 flowing on the node N_4 . By substantially equalizing the voltages on the nodes N_1 and N_3 , the current I_1 flowing on the node N_3 can be substantially equal to a current I_{DOWN} flowing on the node N_1 . In some embodiments, the current I_{DOWN} can be referred to as a down current. By substantially equalizing the voltages on the nodes N_2 and N_4 , the current I_2 flowing on the node N_4 can be substantially equal to a current I_{UP} flowing on the node N_2 . In some embodiments, the current I_{UP} can be referred to as an up current. The current I_{DOWN} can be substantially equal to the current I_{UP} . By substantially equalizing the currents I_{UP} and I_{DOWN} , reference spur, static phase error, and/or jitter at an output end of the integrated circuit **100** can be desirably reduced.

FIG. **2** is a schematic drawing illustrating another exemplary integrated circuit including an exemplary charge pump circuit. Items of FIG. **2** that are the same items in FIG. **1** are indicated by the same reference numerals, increased by 100. In FIG. **2**, a current source **210** can include transistors M_1 and M_2 . In some embodiments, the transistors M_1 and M_2 can be NMOS transistors. Gates of the transistors M_1 and M_2 can be coupled with each other. Drains of the transistors M_1 and M_2 can be coupled with the nodes N_1 and N_3 , respectively. Sources of the transistors M_1 and M_2 can be coupled to a power source, e.g., power source V_{SS} or ground.

Referring again to FIG. **2**, a current source **220** can include transistors M_3 and M_4 . In some embodiments, the transistors M_3 and M_4 can be PMOS transistors. Gates of the transistors M_3 and M_4 can be coupled with each other. Drains of the transistors M_3 and M_4 can be coupled with the nodes N_2 and N_4 , respectively. Sources of the transistors M_3 and M_4 can be coupled to a power source, e.g., power source V_{DD} . It is noted that the disposition, number, and/or type of transistors in the current sources **210** and **220** are merely exemplary. One skilled in the art can modify them to achieve desired current sources.

Referring again to FIG. **2**, a switch circuit **230** can include pass gates (not labeled). In some embodiments, two pass gates can be coupled in series. The series pass gates can be coupled with another series pass gates in parallel. Each of the pass gates can receive at least one control signal, e.g., signals UP/UPB or DN/DNB, to turn on or off transistors of the pass gates so as to charge or discharge a capacitor (not shown) coupled with an output end VOP of the switch circuit **230**. The switch circuit **230** can include an amplifier (not labeled). The amplifier can be disposed between the two series pass gates. It is noted that the disposition, number, and/or type of transistors of the switch circuit **230** are merely exemplary. One skilled in the art can modify them to achieve a desired switch circuit.

Referring to FIG. **2**, a circuit **240** can be disposed between the nodes N_1 and N_3 . In some embodiments, the circuit **240**

can include an amplifier A_1 and a transistor M_5 , such as an NMOS transistor. The amplifier A_1 can have a gain of about 60 dB or more. Input ends of the amplifier A_1 can be coupled between the nodes N_1 and N_3 . An output end of the amplifier A_1 can be coupled with a gate of the transistor M_5 . A source of the transistor M_5 can be coupled with the node N_3 .

As noted, the circuit **240** is configured for substantially equalizing the voltages on the nodes N_1 and N_3 . For example, the amplifier A_1 can detect the voltages on the nodes N_1 and N_3 . If the voltage on the node N_1 is higher than that of the node N_3 , the amplifier A_1 can output a signal to the transistor M_5 . The signal can control the transistor M_5 for pulling up the voltage on the node N_3 such that the voltage on the node N_1 is substantially equal to the voltage on the node N_3 . If the voltage on the node N_1 is lower than that of the node N_3 , the amplifier A_1 can output a signal to the transistor M_5 . The signal can control the transistor M_5 for pulling down the voltage on the node N_3 such that the voltage on the node N_1 is substantially equal to the voltage on the node N_3 .

As noted, the currents I_{DOWN} and I_1 flowing on the nodes N_1 and N_3 , respectively, are substantially equal to currents flowing through the transistors M_1 and M_2 , respectively. The currents I_{DOWN} and I_1 are related to the voltage drops V_{Ds} of the transistors M_1 and M_2 , respectively. As noted, the sources of the transistors M_1 and M_2 are coupled to the same voltage source, e.g., V_{SS} or ground. Since the circuit **240** substantially equalizes the voltages on the nodes N_1 and N_3 , i.e., the drains of the transistors M_1 and M_2 , respectively. The voltage drop V_{is} of the transistors M_1 can be substantially equal to that of the transistor M_2 . The current I_{DOWN} can be substantially equal to the current I_1 .

Referring to FIG. **2**, the circuit **250** can be disposed between the nodes N_2 and N_4 . In some embodiments, the circuit **250** can include an amplifier A_2 and a transistor M_6 , e.g., a PMOS transistor. The amplifier A_2 can have a gain of about 60 dB or more. Input ends of the amplifier A_2 can be coupled between the nodes N_2 and N_4 . An output end of the amplifier A_2 can be coupled with a gate of the transistor M_6 . A source of the transistor M_6 can be coupled with the node N_4 .

As noted, the circuit **250** is configured for substantially equalizing the voltages on the nodes N_2 and N_4 . For example, the amplifier A_2 can detect the voltages on the nodes N_2 and N_4 . If the voltage on the node N_2 is higher than that of the node N_4 , the amplifier A_2 can output a signal to the transistor M_6 . The signal can control the transistor M_6 to pull up the voltage on the node N_4 such that the voltage on the node N_2 is substantially equal to the voltage on the node N_4 . If the voltage on the node N_2 is lower than that of the node N_4 , the amplifier A_2 can output a signal to the transistor M_6 . The signal can control the transistor M_6 to pull down the voltage on the node N_4 such that the voltage on the node N_2 is substantially equal to the voltage on the node N_4 .

As noted, the currents I_{UP} and I_2 flowing on the nodes N_2 and N_4 , respectively, are substantially equal to currents flowing through the transistors M_3 and M_4 , respectively. The currents I_{UP} and I_2 are related to the voltage drops V_{is} of the transistors M_3 and M_4 , respectively. As noted, the sources of the transistors M_3 and M_4 are coupled to the same voltage source, e.g., V_{DD} . Since the circuit **240** substantially equalizes the voltages on the nodes N_2 and N_4 , i.e., the drains of the transistors M_3 and M_4 , respectively. The voltage drop V_{Ds} of the transistors M_3 can be substantially equal to that of the transistor M_4 . The current I_{UP} can be substantially equal to the current I_2 . Since the current I_1 is substantially equal to the current I_2 , the current I_{UP} can be substantially equal to the current I_{DOWN} , too. In some embodiments, even if the voltage on the output end VOP of the charge pump circuit **201** may

shift up or down, the current I_{UP} can be substantially equal to the current I_{DOWN} . By substantially equalizing the currents I_{UP} and I_{DOWN} , the reference spur, the static phase error, and/or jitter can be desirably reduced when the phase-locked system is locked. It is noted that the disposition, number, and/or type of the amplifiers and transistors of the circuits **240** and **250** are merely exemplary. One skilled in the art can modify them to achieve desired circuits.

As noted, the current I_{UP} can be substantially equal to the current I_{DOWN} . It is found that the currents I_{UP} and I_{DOWN} may be different from a predetermined current that is predetermined to charge or discharge the capacitor (not shown) coupled with the output end VOP of the charge pump circuit **201**. The mismatch of the predetermined current and the currents I_{UP} and I_{DOWN} may result from the dimensions, e.g., length, of the transistors of the charge pump circuit **200**. For example, the predetermined current is about 100 μ A and the currents I_{UP} and I_{DOWN} can be about 80 μ A. In some embodiments, adjusting the currents I_{UP} and I_{DOWN} to be substantially equal to the predetermined current is desired.

Referring again to FIG. 2, the charge pump circuit **201** can include a current source **255**. The current source **255** can be coupled between a power source, e.g., the power source V_{DD} , and a resistor R_2 , which is coupled with another power source, e.g., the power source V_{SS} . The current source **255** can be coupled with an input end of the comparator **260**.

In some embodiments, the current source **220** can include a transistor M_7 . The transistor M_7 can be, for example, a PMOS transistor. A source of the transistor M_7 can be coupled with a voltage source, e.g., the voltage source V_{DD} . A drain of the transistor M_7 can be coupled with a resistor R_1 , which is coupled with another power source, e.g., the power source V_{SS} . A gate of the transistor M_7 can be coupled with the gates of the transistors M_2 and M_4 . By applying the same voltage to gates of the transistors M_2 , M_4 , and M_7 , the current I_2 flowing through the transistor M_4 can be mirrored to the transistors M_4 and M_7 such that the current I_{UP} is substantially equal to a charge pump current I_{pump} flows through the transistor M_7 .

Referring to FIG. 2, the transistor M_7 and the current source **255** can be coupled with the input ends of the comparator **260**. The charge pump circuit **201** can include a controller **270** coupled with an output end of the comparator **260**. The controller **270** can be coupled with an adjustable resistance circuit R_S disposed on a conductive line **235**. In some embodiments, the adjustable resistance circuit R_S can be disposed between the circuits **240** and **250**. By adjusting the resistance of the adjustable resistance circuit R_S , the charge pump current I_{pump} can be adjusted to be substantially equal to a predetermined current I_{SS} that is provided from the current source **255**.

As noted, the current source **255** is configured to provide the predetermined current I_{SS} . The comparator **260** can receive and compare the predetermined current I_{SS} and the charge pump current I_{pump} so as to output an output signal to a controller **270**. Corresponding to the output signal from the comparator **260**, the controller **270** is configured to adjust the resistance of the adjustable resistance circuit R_S .

For example, if the predetermined current I_{SS} is larger than the charge pump current I_{pump} , the controller **270** can adjust the resistance of the adjustable resistance circuit R_S to a lower resistance so as to increase the current I_2 flowing through the transistor M_4 . Since the current I_2 is increased, the charge pump current I_{pump} can be increased to a level that is substantially equal to the predetermined current I_{SS} .

If the predetermined current I_{SS} is smaller than the charge pump current I_{pump} , the controller **270** can adjust the resistance of the adjustable resistance circuit R_S to a higher resis-

tance so as to reduce the current I_2 flowing through the transistor M_4 . Since the current I_2 is decreased, the charge pump current I_{pump} can be decreased to a level that is substantially equal to the predetermined current I_{SS} . By adjusting the resistance of the adjustable resistance circuit R_S , the charge pump current I_{pump} can be substantially equal to the predetermined current I_{SS} .

FIG. 3 is a schematic drawing illustrating an exemplary controller coupled with an exemplary adjustable resistance circuit R_S . In FIG. 3, the controller **270** can include a counter **310**. The adjustable resistance circuit R_S can include a series of resistors r_1 - r_n and a series of switches s_1 - s_n . Each of the switches s_1 - s_n is disposed in parallel with a corresponding one of the resistors r_1 - r_n . The counter **310** is configured to turn on or off at least one of the switches s_1 - s_n to adjust the resistance of the adjustable resistance circuit R_S . It is noted that the adjustable resistance circuit R_S described above in conjunction with FIG. 3 is merely exemplary. One skilled in the art can use any adjustable resistance circuit to adjust the resistance between circuits **240** and **250**.

FIG. 4 is a schematic drawing illustrating a system including an exemplary integrated circuit disposed over a substrate board. In FIG. 4, a system **400** can include an integrated circuit **402** disposed over a substrate board **401**. The substrate board **401** can include a printed circuit board (PCB), a printed wiring board and/or other carrier that is capable of carrying an integrated circuit. The integrated circuit **402** can include a charge pump circuit that is similar to the charge pump circuit **101** or **201** described above in conjunction with FIGS. 1 and 2, respectively. The integrated circuit **402** can be electrically coupled with the substrate board **401**. In embodiments, the integrated circuit **402** can be electrically coupled with the substrate board **401** through bumps **405**. In other embodiments, the integrated circuit **402** can be electrically coupled with the substrate board **401** through wire bonding. The system **400** can be part of an electronic system such as computers, wireless communication devices, computer-related peripherals, entertainment devices, or the like.

In embodiments, the system **400** including the integrated circuit **402** can provide an entire system in one IC, so-called system on a chip (SOC) or system on integrated circuit (SOIC) devices. These SOC devices may provide, for example, all of the circuitry needed to implement a radio system, a television, a video apparatus, a satellite broadcast system, an instrumentation system, a cell phone, personal data assistant (PDA), digital VCR, digital camcorder, digital camera, MP3 player, or the like in a single integrated circuit.

From the foregoing, in a first embodiment, an integrated circuit includes a first current source. A second current source is electrically coupled with the first current source via a conductive line. A switch circuit is coupled between the first current source and the second current source. A first circuit is coupled between a first node and a second node. The first node is disposed between the first current source and the switch circuit. The second node is coupled with the first current source. The first circuit is configured for substantially equalizing voltages on the first node and the second node. A second circuit is coupled between a third node and a fourth node. The third node is disposed between the second current source and the switch circuit. The fourth node is coupled with the second current source. The second circuit is configured for substantially equalizing voltages on the third node and the fourth node.

In a second embodiment, an integrated circuit includes a first current source and a second current source. A switch circuit is coupled between the first current source and the second current source. A first node is disposed between the

first current source and the switch circuit. A second node is disposed between the second current source and the switch circuit. A first transistor is coupled with the first current. A third node is disposed between the first transistor and the first current source. A first amplifier is coupled between the first node and the third node. A second transistor is coupled with the second current source. A fourth node is between the second transistor and the second current source. A second amplifier is coupled between the second node and the fourth node.

In a third embodiment, a method of operating a charge pump circuit of a phase-locked system is provided. The method includes substantially equalizing voltages on a first node and a second node. The first node is disposed between a first current source and a switch circuit of the charge pump circuit. The second node is coupled with the first current source. The method further includes substantially equalizing voltages on a third node and a fourth node. The third node is disposed between the switch circuit and a second current source of the charge pump circuit. The fourth node is coupled with the second current source of the charge pump circuit.

The foregoing outlines features of several embodiments so that those skilled in the art may better understand the aspects of the present disclosure. Those skilled in the art should appreciate that they may readily use the present disclosure as a basis for designing or modifying other processes and structures for carrying out the same purposes and/or achieving the same advantages of the embodiments introduced herein. Those skilled in the art should also realize that such equivalent constructions do not depart from the spirit and scope of the present disclosure, and that they may make various changes, substitutions, and alterations herein without departing from the spirit and scope of the present disclosure.

What is claimed is:

1. An integrated circuit comprising:

a first current source;
 a second current source electrically coupled with the first current source via a conductive line;
 a switch circuit coupled between the first current source and the second current source;
 a first circuit coupled between a first node and a second node, the first node being disposed between the first current source and the switch circuit, the second node being coupled with the first current source, wherein the first circuit is configured for substantially equalizing voltages on the first node and the second node;
 a second circuit coupled between a third node and a fourth node, the third node being disposed between the second current source and the switch circuit, the fourth node being coupled with the second current source, wherein the second circuit is configured for substantially equalizing voltages on the third node and the fourth node;
 a third current source;
 a comparator coupled between the second current source and the third current source;
 a controller coupled with an output end of the comparator; and
 an adjustable resistance circuit coupled with the controller, the adjustable resistance circuit being disposed between the first circuit and the second circuit.

2. The integrated circuit of claim 1, wherein

the first current source includes a first transistor and a second transistor;
 the second current source includes a third transistor and a fourth transistor;
 the first circuit is disposed between drains of the first and second transistors, wherein the first circuit is configured

for substantially equalizing voltages on the drains of the first and second transistors; and

the second circuit is disposed between drains of the third and fourth transistors, wherein the second circuit is configured for substantially equalizing voltages on the drains of the third and fourth transistors.

3. The integrated circuit of claim 2, wherein the first circuit comprises

a first amplifier coupled between the drains of the first and second transistors; and
 a fifth transistor having a gate coupled with an output end of the first amplifier.

4. The integrated circuit of claim 3, wherein the second circuit comprises:

a second amplifier coupled between the drains of the third and fourth transistors; and
 a sixth transistor having a gate coupled with an output end of the second amplifier.

5. The integrated circuit of claim 4, wherein each of the first and second amplifiers has a gain of about 60 dB or more.

6. The integrated circuit of claim 1, wherein the comparator is configured to compare a first current from the second current source and a second current from the third current source to output a signal for triggering the controller to adjust a resistance of the adjustable resistance circuit.

7. The integrated circuit of claim 1, wherein the controller includes a counter, the adjustable resistance circuit includes a series of resistors and a series of switches, and each of the switches is disposed in parallel with a corresponding one of the resistors, wherein the counter is configured to turn on or off at least one of the switches to adjust a resistance of the adjustable resistance circuit.

8. An integrated circuit comprising:

a first current source;
 a second current source;
 a switch circuit coupled between the first current source and the second current source, wherein a first node is between the first current source and the switch circuit, and a second node is between the second current source and the switch circuit;
 a first transistor coupled with the first current source, wherein a third node is disposed between the first transistor and the first current source;
 a first amplifier coupled between the first node and the third node;
 a second transistor coupled with the second current source, wherein a fourth node is disposed between the second transistor and the second current source;
 a second amplifier coupled between the second node and the fourth node;
 a third current source;
 a comparator coupled between the second current source and the third current source;
 a controller coupled with an output end of the comparator; and
 an adjustable resistance circuit coupled with the controller, the adjustable resistance circuit being disposed between the first transistor and the second transistor.

9. The integrated circuit of claim 8, wherein each of the first and second amplifiers has a gain of about 60 dB or more.

10. The integrated circuit of claim 8, wherein the comparator is configured to compare a first current from the second current source and a second current from the third current source to output a signal for triggering the controller to adjust a resistance of the adjustable resistance circuit.

11. The integrated circuit of claim 10, wherein the controller includes a counter, the adjustable resistance circuit

9

includes a series of resistors and a series of switches, and each of the switches is disposed in parallel with a corresponding one of the resistors, wherein the counter is configured to turn on or off at least one of the switches to adjust a resistance of the adjustable resistance circuit.

12. A method of operating a charge pump circuit of a phase-locked system, the method comprising:

substantially equalizing voltages on a first node and a second node, wherein the first node is disposed between a first current source and a switch circuit of the charge pump circuit, and the second node is coupled with the first current source;

substantially equalizing voltages on a third node and a fourth node, wherein the third node is disposed between the switch circuit and a second current source of the charge pump circuit, and the fourth node is coupled with the second current source; and

adjusting a resistance of an adjustable resistance circuit disposed between the [first] second node and the [third] fourth node so as to adjust a charge pump current flowing through the first current source and the second current source.

13. The method of claim 12, wherein substantially equalizing voltages on the first node and the second node comprises:

detecting the voltages on the first node and the second node; and

adjusting the voltage on the second node so as to substantially equalize the voltages on the first node and the second node.

14. The method of claim 13, wherein detecting the voltages on the first node and the second node comprises detecting the voltages on drains of a first transistor and a second transistor of the first current source.

15. The method of claim 12, wherein substantially equalizing voltages on the third node and the fourth node comprises:

10

detecting the voltages on the third node and the fourth node; and

adjusting the voltage on the fourth node so as to substantially equalize the voltages on the third node and the fourth node.

16. The method of claim 15, wherein detecting the voltages on the third node and the fourth node comprises detecting the voltages on drains of a third transistor and a fourth transistor of the second current source.

17. The method of claim 12, wherein adjusting the resistance of the adjustable resistance circuit comprises:

comparing the charge pump current with a predetermined current so as to generate an output signal; and responding to the output signal, adjusting the resistance of the adjustable resistance circuit such that the charge pump current is substantially equal to the predetermined current.

18. A circuit comprising:

a first current source having a first node and a second node; a second current source having a third node and a fourth node;

a switch circuit coupled between the first node and the third node;

a first circuit coupled with the first node and the second node and configured to equalize voltages on the first node and the second node;

a second circuit coupled with the third node and the fourth node and configured to equalize voltages on the third node and the fourth node;

an adjustable resistance circuit coupled between the first circuit and the second circuit; and

a controller configured to adjust a current flowing through the first current source and the second current source by adjusting a resistance of the adjustable resistance circuit.

* * * * *