



(51) International Patent Classification:
E05B 15/14 (2006.01)

(21) International Application Number:

PCT/US2011/026945

(22) International Filing Date:

3 March 2011 (03.03.2011)

(25) Filing Language:

English

(26) Publication Language:

English

(30) Priority Data:

201010129888.0 4 March 2010 (04.03.2010)

CN

(71) Applicant (for all designated States except US): **MUL-T-LOCK TECHNOLOGIES LTD.** [IL/IL]; PO Box 637, 81104 Yavne (IL).

(71) Applicant (for VC only): **KLEIN, David** [US/IL]; 2 Ha-Hagana Street, 76210 Rehovot (IL).

(72) Inventors; and

(75) Inventors/Applicants (for US only): **MATYKO, Adalbert** [IL/IL]; 28 Shderot Tel Chai, 77510 Ashdod (IL). **NOTKIN, Leon** [IL/IL]; 4 Meltzer Street, 76285 Rehovot (IL).

(74) Agent: **KLEIN, David**; Beit HaRof'im, 18 Menuha Ve-Nahala Street, Room 27, 76209 Rehovot (IL).

[Continued on next page]

(54) Title: MORTISE LOCK WITH SELECTABLE FUNCTIONS

(57) Abstract: A mortise lock (10) including a case (12), a latch bolt (16), at least one locking bolt (18), and a spindle hub (24) mechanically linked to the latch bolt (16) by a latch follower hub (26) for retracting the latch bolt (16) by rotation of the spindle hub (24), characterised by an activation receiver (54) for slam-lock operation and an activation receiver (56) for emergency operation.



WO 2011/109573 A2

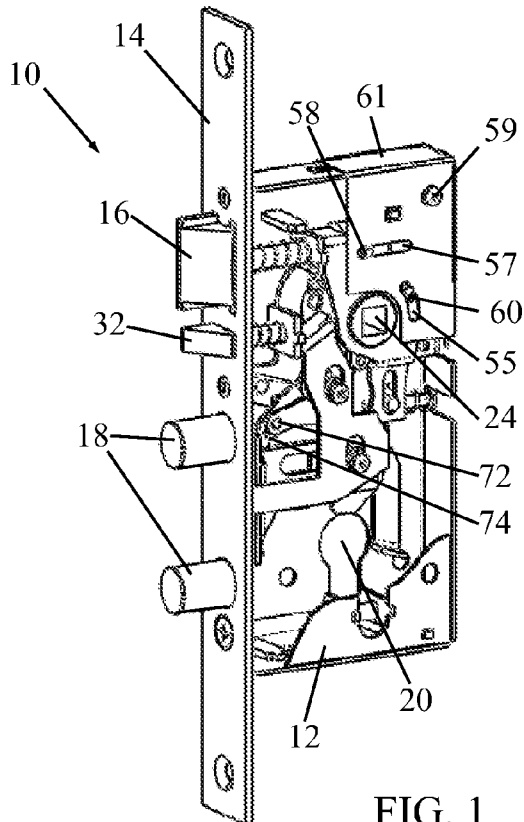

FIG. 1



(81) Designated States (unless otherwise indicated, for every kind of national protection available): AE, AG, AL, AM, AO, AT, AU, AZ, BA, BB, BG, BH, BR, BW, BY, BZ, CA, CH, CL, CN, CO, CR, CU, CZ, DE, DK, DM, DO, DZ, EC, EE, EG, ES, FI, GB, GD, GE, GH, GM, GT, HN, HR, HU, ID, IL, IN, IS, JP, KE, KG, KM, KN, KP, KR, KZ, LA, LC, LK, LR, LS, LT, LU, LY, MA, MD, ME, MG, MK, MN, MW, MX, MY, MZ, NA, NG, NI, NO, NZ, OM, PE, PG, PH, PL, PT, RO, RS, RU, SC, SD, SE, SG, SK, SL, SM, ST, SV, SY, TH, TJ, TM, TN, TR, TT, TZ, UA, UG, US, UZ, VC, VN, ZA, ZM, ZW.

(84) Designated States (unless otherwise indicated, for every kind of regional protection available): ARIPO (BW, GH,

GM, KE, LR, LS, MW, MZ, NA, SD, SL, SZ, TZ, UG, ZM, ZW), Eurasian (AM, AZ, BY, KG, KZ, MD, RU, TJ, TM), European (AL, AT, BE, BG, CH, CY, CZ, DE, DK, EE, ES, FI, FR, GB, GR, HR, HU, IE, IS, IT, LT, LU, LV, MC, MK, MT, NL, NO, PL, PT, RO, RS, SE, SI, SK, SM, TR), OAPI (BF, BJ, CF, CG, CI, CM, GA, GN, GQ, GW, ML, MR, NE, SN, TD, TG).

Published:

— without international search report and to be republished upon receipt of that report (Rule 48.2(g))

MORTISE LOCK WITH SELECTABLE FUNCTIONS

FIELD OF THE INVENTION

The present invention relates generally to mortise locks with multiple functions in which the functions can be selected or changed at installation thereof.

BACKGROUND OF THE INVENTION

Mortise locks are known that provide a variety of functions, such as but not limited to, deadbolt operation, slam-lock operation, emergency operation and many others. Mortise locks are known that can be changed to operate with or without some of these functions. However, making these changes to the normal operation of the mortise lock has previously required partially or totally disassembling the mortise lock and rearranging or configuring the mortise lock components to achieve the desired mode of operation.

Although such changes can be made reliably by trained personnel at the factory, the task of disassembling the mortise lock is a relatively time consuming process. Moreover disassembling the mortise lock provides opportunities for damaging the components. Additionally, components may become lost during the adjustment process. These problems are accentuated when the changes need to be made in the field by installers or maintenance personnel.

SUMMARY OF THE INVENTION

The present invention seeks to provide an improved and novel mortise lock in which the functions can easily be selected or changed at installation thereof, without disassembling the mortise lock, as is described more in detail hereinbelow.

The installer has four installation options: installing both the slam-lock operation and the emergency operation, just the slam-lock operation, just the emergency operation, or none of them.

It is to be noted that the term "emergency operation" as used throughout the specification and claims refers to both "emergency" and "panic" operation.

There is thus provided in accordance with an embodiment of the invention a mortise lock including a case, a latch bolt, at least one locking bolt, a spindle hub mechanically linked to the latch bolt by a latch follower for retracting the latch bolt by rotation of the spindle hub, an activation receiver for slam-lock operation, wherein when a slam-lock activating member is installed in the activation receiver, the latch bolt is mechanically linked to the at least one locking bolt, such that retraction of the latch bolt into the case releases a catch to permit the at least one locking bolt to extend out of the

case into a locking position, and wherein when the slam-lock activating member is not installed in the activation receiver, the latch bolt is not mechanically linked to the at least one locking bolt, such that retraction of the latch bolt into the case does not affect movement of the at least one locking bolt, and an activation receiver for emergency operation, wherein when an emergency activating member is installed in the activation receiver, the spindle hub is mechanically linked to the at least one locking bolt, such that turning the spindle hub retracts the at least one locking bolt and wherein when the emergency activating member is not installed in the activation receiver, the spindle hub is not mechanically linked to the at least one locking bolt, such that turning the spindle hub does not affect movement of the at least one locking bolt.

In accordance with an embodiment of the invention the catch extends from a pivoted bolt follower, and when the slam-lock activating member is installed in the activation receiver, inward movement of the latch bolt causes the slam-lock activating member to push against an end face of the pivoted bolt follower, so as to release the catch to permit the at least one locking bolt to extend out of the case into the locking position.

In accordance with an embodiment of the invention the at least one locking bolt is spring-loaded by a spring, and the catch, when in engagement with the at least one locking bolt, prevents the spring from pushing out the at least one locking bolt.

In accordance with an embodiment of the invention a spring-loaded lever that pivots about a pivot is connected to a locking bolt mover, and when the emergency activating member is installed in the activation receiver, turning the spindle hub causes the emergency activating member to push against the spring-loaded lever which moves the locking bolt mover to retract the at least one locking bolt into the case.

In accordance with an embodiment of the invention a spring-loaded deadbolt latch is arranged to protrude through the case, wherein an end of the deadbolt latch is arranged to push against a deadbolt follower inside the case and wherein the deadbolt follower engages a deadbolt stopper assembly inside the case, wherein when the deadbolt latch is pushed inwards into the case, the deadbolt latch pushes against the deadbolt follower, thereby geometrically locking the deadbolt stopper assembly into a position that blocks the at least one locking bolt and prevents forcing the at least one locking bolt from being moved inwards into the case, making the at least one locking bolt a deadbolt.

In accordance with an embodiment of the invention a slam-lock activating member and an emergency activating member are installed in the activation receivers for

slam-lock operation and emergency operation, respectively (or just slam-lock operation, or just emergency operation or neither one of slam-lock and emergency operation).

In accordance with an embodiment of the invention the slam-lock activating member is constrained to travel in a straight slot formed in a cover plate.

In accordance with an embodiment of the invention the emergency activating member is constrained to travel in a curved slot formed in a cover plate.

BRIEF DESCRIPTION OF THE DRAWINGS

The present invention will be understood and appreciated more fully from the following detailed description, taken in conjunction with the drawings in which:

Fig. 1 is a simplified pictorial illustration of a mortise lock, constructed and operative in accordance with an embodiment of the present invention;

Figs. 2A and 2B are simplified cutaway illustrations of the mortise lock of Fig. 1, respectively before and after activating deadbolt operation;

Fig. 3 is simplified pictorial cutaway illustration of the mortise lock of Fig. 1, showing activating members installed in activation receivers for both slam-lock operation and emergency operation of the mortise lock, in accordance with an embodiment of the present invention;

Fig. 3A is simplified pictorial cutaway illustration of the mortise lock of Fig. 1, showing the slam-lock mode in operation;

Fig. 4 is simplified pictorial cutaway illustration of the mortise lock of Fig. 1, wherein no activating members have been installed in the activation receivers for emergency operation and slam-lock operation of the mortise lock, in accordance with an embodiment of the present invention;

Fig. 5 is simplified pictorial cutaway illustration of the mortise lock of Fig. 1, wherein the activating member has been installed in the activation receiver for emergency operation and no activating member has been installed in the activation receiver for slam-lock operation of the mortise lock, in accordance with an embodiment of the present invention; and

Fig. 6 is simplified pictorial cutaway illustration of the mortise lock of Fig. 1, wherein the activating member has been installed in the activation receiver for slam-lock operation and no activating member has been installed in the activation receiver for emergency operation of the mortise lock, in accordance with an embodiment of the present invention.

DETAILED DESCRIPTION OF A PREFERRED EMBODIMENT

Reference is now made to Figs. 1 and 3, which illustrate a mortise lock 10, constructed and operative in accordance with a non-limiting embodiment of the present invention.

Mortise lock 10 includes a case 12 that houses the internal parts of the lock. A faceplate 14 is attached to case 12 and has apertures for various bolts to protrude therethrough, such as a latch bolt 16 and one or more locking bolts 18 (in the illustrated embodiment, there are two locking bolts 18 that move together on a common plate). Case 12 has a cylinder aperture 20 for installing therein a cylinder lock 22 (shown in Fig. 3). A spindle hub 24 is provided in case 12 for inserting therein a handle (not shown) for retracting latch bolt 16. This may be accomplished by means of a latch follower 26 (e.g., a tongue that extends outwards from spindle hub 24) which abuts against a tail stop 28 (Fig. 3) on the rod of latch bolt 16. When spindle hub 24 is turned clockwise in the sense of the drawings, latch follower 26 pushes against tail stop 28 causing the latch bolt 16 to be retracted into case 12 (i.e., moved to the right in the sense of the drawing). A return spring 30 (Fig. 3) causes latch bolt 16 to return to its position (leftwards) out of case 12. As is well known in the art, cylinder lock 22 can also be used to retract latch bolt 16, by suitable linkage with tail stop 28 or with latch follower 26 or other mechanism.

Reference is now made to Figs. 2A and 2B, which illustrate activating the deadbolt operation.

A spring-loaded deadbolt latch 32 is arranged to protrude through faceplate 14. The (rightmost) end 34 of deadbolt latch 32 is arranged to push against a slanted shoe 36 of a deadbolt follower 38. The deadbolt follower 38 is constrained to move linearly up and down in the sense of the drawing by means of pins or screws 40 that move in slots 42. An extension 44 of deadbolt follower 38 engages a deadbolt stopper assembly 46, which includes one or more plates 48 and a pin 50. Fig. 2A shows the position when the door (not shown), in which mortise lock 10 is installed, is open, wherein deadbolt latch 32 protrudes through faceplate 14. In this position, the locking bolts 18 are not "dead", that is, they can conceivably be forced into case 12 without anything in case 12 preventing such movement. When the door is closed, deadbolt latch 32 is pushed inwards into case 12 to the position shown in Fig. 2B. This causes the (rightmost) end 34 of deadbolt latch 32 to push against slanted shoe 36, thereby moving deadbolt follower 38 downwards. This in turn causes extension 44 to move plates 48 downwards as well. This causes pin 50 to geometrically lock into a recess 52 of deadbolt stopper assembly 46. The deadbolt stopper assembly 46 is now geometrically locked in place and locking bolts 18 are now

“dead”, that is, they cannot be forced into case 12 because their movement is blocked by deadbolt stopper assembly 46 (locking bolts 18 have become deadbolts).

In accordance with an embodiment of the present invention, mortise lock 10 can be adapted for operation in a slam-lock mode. As is known in the art, in general, a slam-lock mode is a mode in which a locking bolt or the like is normally positioned in an extended position and is constrained, such as by a double-acting spring, so that when the door is closed or slammed shut, the locking bolt will initially retract upon closing engagement of the door and then immediately extend in order to lock and retain the door in closed engagement. As will now be explained with reference to Figs. 3 and 3A, in the present invention, in the slam-lock mode latch bolt 16 is mechanically linked to locking bolts 18, such that when the door is closed or slammed shut, retraction of latch bolt 16 releases the retracted locking bolts 18 so that they immediately extend out of case 12 and lock and retain the door in closed engagement.

As seen in Fig. 3, mortise lock 10 is provided with activation receivers 54 and 56 for slam-lock operation and emergency operation, respectively. Fig. 3 illustrates mortise lock 10 with activating members 58 and 60, respectively installed in activation receivers 54 and 56 for both slam-lock operation and emergency operation of the mortise lock. The activation receivers 54 and 56 may be sockets or holes or other suitable mounting provisions, and activating members 58 and 60 may be pins or screws (in which case the holes are tapped) that fit into the sockets or holes or other mounting provisions. The activating members 58 and 60 may be easily installed when installing mortise lock 10 in the door and covered over with a cover plate 61 (Fig. 1), secured to case 12 with one or more fasteners 59. The activating members 58 and 60 may be constrained to travel in a straight slot 57 and a curved slot 55, respectively, formed in cover plate 61.

In the case of slam-lock mode, activating member 58 (e.g., a pin) is installed in activation receiver 54 (e.g., a receiving hole). When activating member 58 is installed in activation receiver 54, inward movement of latch bolt 16 causes activating member 58 to push against an end face 62 of a pivoted bolt follower 64 (i.e., latch bolt 16 is now mechanically linked to bolt follower 64 which is linked to the locking bolts 18). When activating member 58 is not installed in activation receiver 54, latch bolt 16 is disconnected from bolt follower 64, and inward movement of latch bolt 16 does not cause any movement of pivoted bolt follower 64.

The action of activating member 58 pushing against end face 62, causes bolt follower 64 to pivot and a spring-loaded catch 66 (Fig. 3A) is moved out of engagement

with locking bolts 18. (Note in Fig. 3A that activating member 58 has traveled to the right end of straight slot 57.) Locking bolts 18 are spring-loaded (e.g., by a spring 67), and catch 66, when in engagement with locking bolts 18, prevents spring 67 from pushing out the locking bolts 18. Upon release of catch 66, the spring-loaded locking bolts 18 are free to be thrust out of case 12 (e.g., by spring action of spring 67) to the locked position shown in Fig. 2B thereby completing the slam-lock operation.

In accordance with an embodiment of the present invention, mortise lock 10 can be adapted for operation in an emergency mode. As is known in the art, an emergency mode is a mode in which a locking bolt or the like can be retracted from one side of the door (usually the inside of the door) even if the door is nominally locked with the cylinder lock (i.e., overriding the cylinder lock). As will now be explained with reference to Figs. 3 and 3A, in the present invention, in the emergency mode spindle hub 24 is mechanically linked to locking bolts 18, such that turning spindle hub 24 with the handle retracts the locking bolts 18 and overrides cylinder lock 22.

In the case of emergency mode, activating member 60 (e.g., a pin) is installed in activation receiver 56 (e.g., a receiving hole). When activating member 60 is installed in activation receiver 56, turning spindle hub 24 with the handle causes activating member 60 to push against a spring-loaded lever 68 that pivots about a pivot 70 (Fig. 3 shows lever 68 pushed to the right). An end 72 (leftmost end) of lever 68 is connected (e.g., pinned) to a locking bolt mover 74 (72 and 74 are seen in Figs. 1 and 2B). Locking bolt mover 74, when moved to the right, can override the cylinder lock 22 and retract the locking bolts 18. Thus, in the emergency mode, spindle hub 24 is mechanically linked to locking bolts 18 via lever 68. When activating member 60 is not installed in activation receiver 56, spindle hub 24 is disconnected from lever 68, and turning spindle hub 24 does not cause any movement of pivoted lever 68.

The action of activating member 60 pushing against spring-loaded lever 68, moves the lower right end of lever 68 to the right in the sense of the drawings and causes the left end 72 of lever 68 to move locking bolt mover 74 to the right and retract locking bolts 18 into case 12 (the position shown in Fig. 3), thereby completing the emergency operation.

The installer has the option of installing both the slam-lock operation and the emergency operation by installing both activating members 58 and 60, as in Figs. 1-3.

Reference is now made to Fig. 4, which illustrates another option in which no activating members have been installed in the activation receivers, so there is no emergency operation and no slam-lock operation.

Reference is now made to Fig. 5, which illustrates another option in which the activating member 60 has been installed in the activation receiver 56 for emergency operation and no activating member has been installed in the activation receiver 54 and there is no slam-lock operation.

Reference is now made to Fig. 6, which illustrates another option in which the activating member 58 has been installed in the activation receiver 54 for slam-lock operation and no activating member has been installed in the activation receiver 56 and there is no emergency operation.

It will be appreciated by persons skilled in the art that the present invention is not limited by what has been particularly shown and described hereinabove. Rather the scope of the present invention includes both combinations and subcombinations of the features described hereinabove as well as modifications and variations thereof which would occur to a person of skill in the art upon reading the foregoing description and which are not in the prior art.

C L A I M S

What is claimed is:

1. A mortise lock (10) comprising:
 - a case (12);
 - a latch bolt (16);
 - at least one locking bolt (18); and
 - a spindle hub (24) mechanically linked to said latch bolt (16) by a latch follower (26) for retracting said latch bolt (16) by rotation of said spindle hub (24);characterised by an activation receiver (54) for slam-lock operation, wherein when a slam-lock activating member (58) is installed in said activation receiver (54), said latch bolt (16) is mechanically linked to said at least one locking bolt (18), such that retraction of said latch bolt (16) into said case (12) releases a catch (66) to permit said at least one locking bolt (18) to extend out of said case (12) into a locking position, and wherein when the slam-lock activating member (58) is not installed in said activation receiver (54), said latch bolt (16) is not mechanically linked to said at least one locking bolt (18), such that retraction of said latch bolt (16) into said case (12) does not affect movement of said at least one locking bolt (18); and
 - an activation receiver (56) for emergency operation, wherein when an emergency activating member (60) is installed in said activation receiver (56), said spindle hub (24) is mechanically linked to said at least one locking bolt (18), such that turning said spindle hub (24) retracts said at least one locking bolt (18) and wherein when the emergency activating member (60) is not installed in said activation receiver (56), said spindle hub (24) is not mechanically linked to said at least one locking bolt (18), such that turning said spindle hub (24) does not affect movement of said at least one locking bolt (18).
2. The mortise lock (10) according to claim 1, wherein said catch (66) extends from a pivoted bolt follower (64), and when said slam-lock activating member (58) is installed in said activation receiver (54), inward movement of said latch bolt (16) causes said slam-lock activating member (58) to push against an end face (62) of said pivoted bolt follower (64), so as to release said catch (66) to permit said at least one locking bolt (18) to extend out of said case (12) into the locking position.
3. The mortise lock (10) according to claim 1 or claim 2, wherein said at least one locking bolt (18) is spring-loaded by a spring (67), and said catch (66), when in engagement with said at least one locking bolt (18), prevents said spring (67) from pushing out said at least one locking bolt (18).

4. The mortise lock (10) according to any of claims 1-3, wherein a spring-loaded lever (68) that pivots about a pivot (70) is connected to a locking bolt mover (74), and when said emergency activating member (60) is installed in said activation receiver (56), turning said spindle hub (24) causes said emergency activating member (60) to push against said spring-loaded lever (68) which moves said locking bolt mover to retract said at least one locking bolt (18) into said case (12).

5. The mortise lock (10) according to any of claims 1-4, further comprising a slam-lock activating member (58) and an emergency activating member (60) installed in said activation receivers (54) and (56), respectively.

6. The mortise lock (10) according to any of claims 1-4, further comprising a slam-lock activating member (58) installed in said activation receiver (54).

7. The mortise lock (10) according to any of claims 1-4, further comprising an emergency activating member (60) installed in said activation receiver (56).

8. The mortise lock (10) according to any of claims 1-4, wherein said activation receivers (54) and (56) have no activating members installed therein.

9. The mortise lock (10) according to claim 5 or claim 6, wherein said slam-lock activating member (58) is constrained to travel in a straight slot (57) formed in a cover plate (61).

10. The mortise lock (10) according to claim 5 or claim 7, wherein said emergency activating member (60) is constrained to travel in a curved slot (55) formed in a cover plate (61).

11. The mortise lock (10) according to claim 1, further comprising:

a spring-loaded deadbolt latch (32) arranged to protrude through said case (12), wherein an end of said deadbolt latch (32) is arranged to push against a deadbolt follower (38) inside said case (12) and wherein said deadbolt follower (38) engages a deadbolt stopper assembly (46) inside said case (12), wherein when said deadbolt latch (32) is pushed inwards into said case (12), said deadbolt latch (32) pushes against said deadbolt follower (38), thereby geometrically locking said deadbolt stopper assembly (46) into a position that blocks said at least one locking bolt (18) and prevents forcing said at least one locking bolt (18) from being moved inwards into said case (12), making said at least one locking bolt (18) a deadbolt.

12. A mortise lock (10) comprising:

a case (12); and

at least one locking bolt (18);

characterised by a spring-loaded deadbolt latch (32) arranged to protrude through said case (12), wherein an end of said deadbolt latch (32) is arranged to push against a deadbolt follower (38) inside said case (12) and wherein said deadbolt follower (38) engages a deadbolt stopper assembly (46) inside said case (12), wherein when said deadbolt latch (32) is pushed inwards into said case (12), said deadbolt latch (32) pushes against said deadbolt follower (38), thereby geometrically locking said deadbolt stopper assembly (46) into a position that blocks said at least one locking bolt (18) and prevents forcing said at least one locking bolt (18) from being moved inwards into said case (12), making said at least one locking bolt (18) a deadbolt.

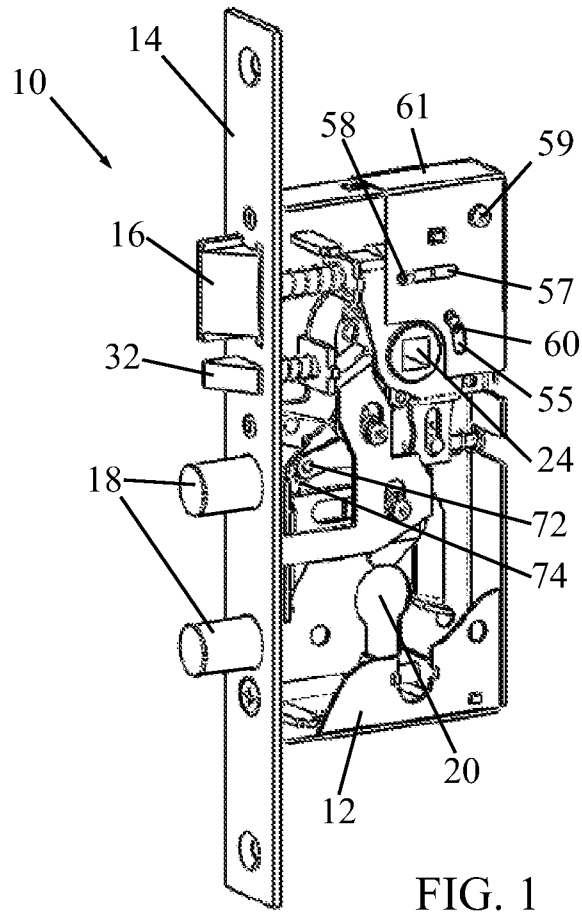

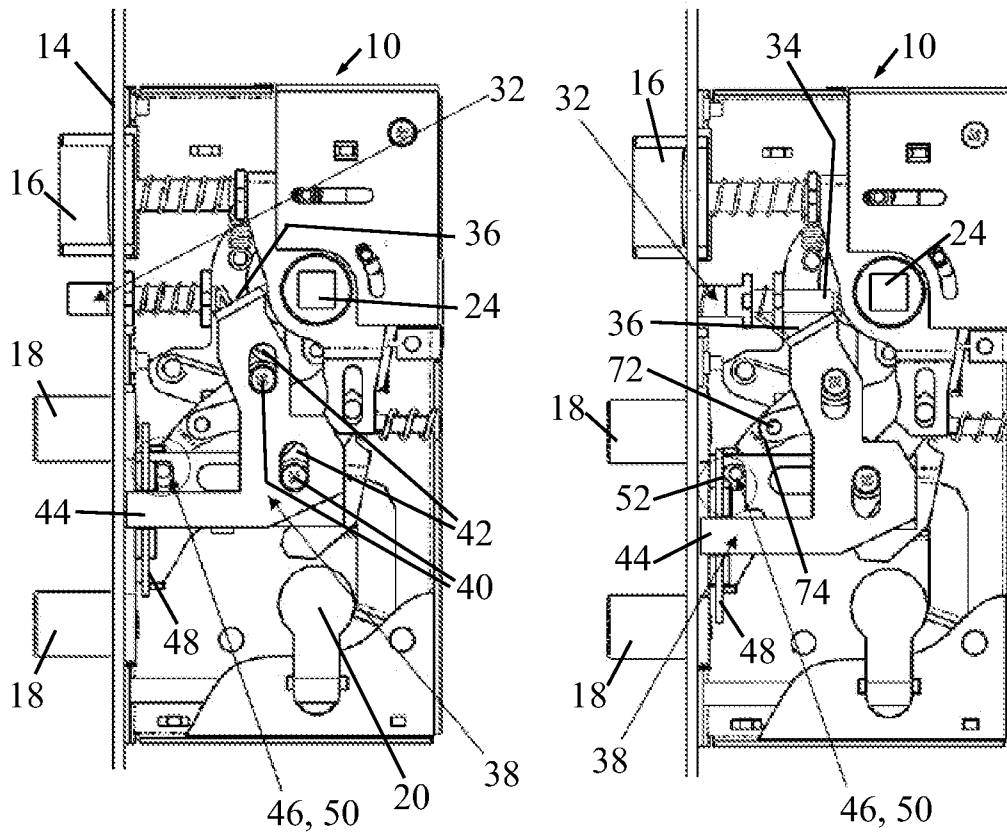

FIG. 2A

FIG. 2B

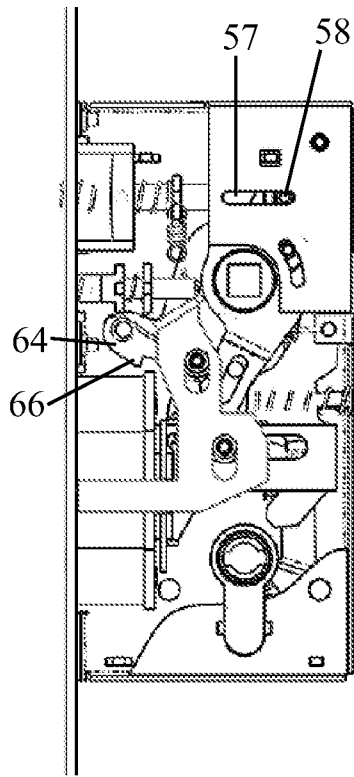

FIG. 3A

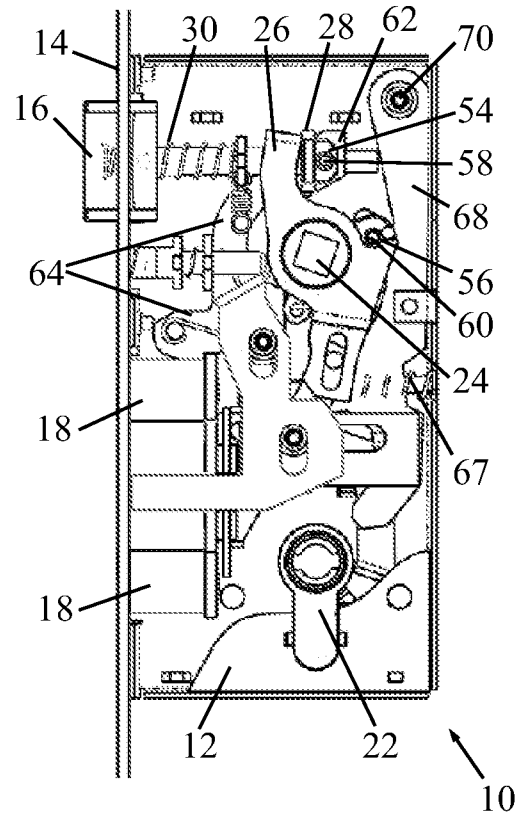

FIG. 3

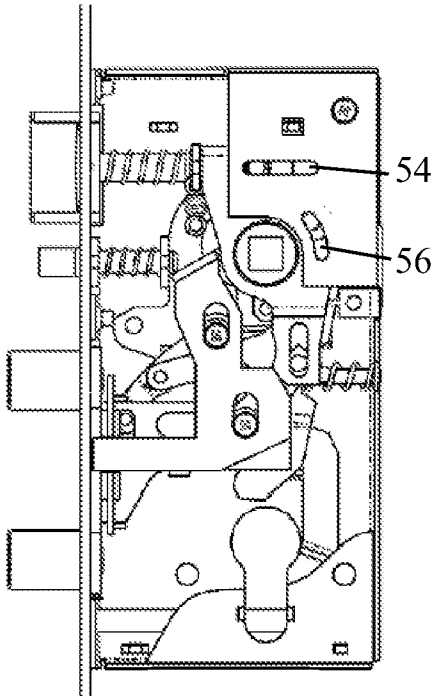

FIG. 4

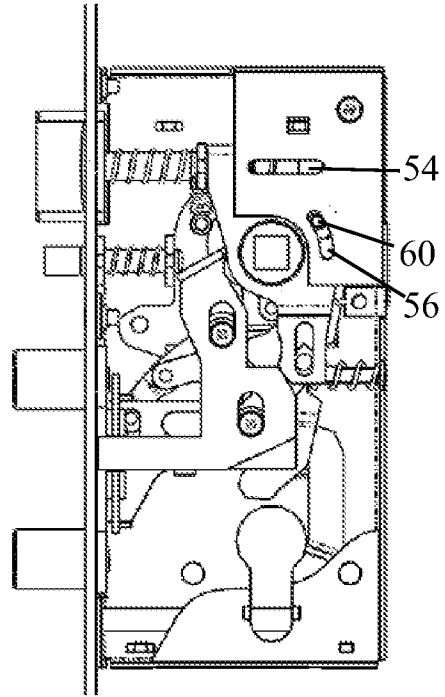

FIG. 5

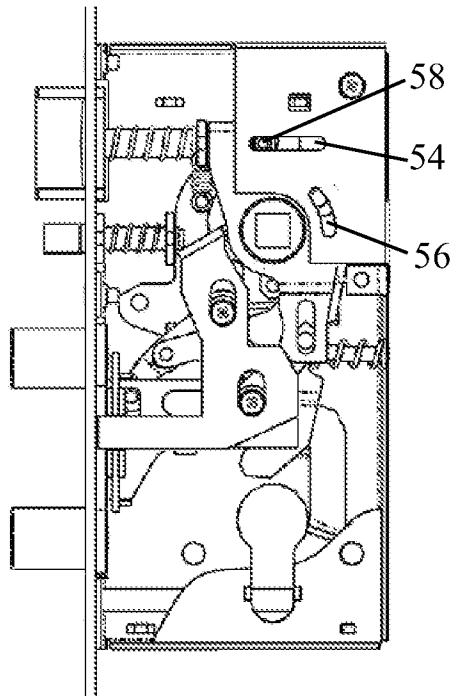

FIG. 6