

12

EUROPEAN PATENT APPLICATION

21 Application number: 89311224.3

51 Int. Cl.⁵ **A63B 65/02**

22 Date of filing: 31.10.89

30 Priority: 03.11.88 GB 8825722

43 Date of publication of application:
09.05.90 Bulletin 90/19

34 Designated Contracting States:
BE DE FR LU NL SE

71 Applicant: **Smith, Ian**
8 Countess Close Eaton Socon
Huntingdon Cambridgeshire(GB)

Applicant: **Hummel, Peter**
Schllinkergarten 16
D-6465 Biebergemund-Wirtheim(DE)

72 Inventor: **Smith, Ian**
8 Countess Close Eaton Socon
Huntingdon Cambridgeshire(GB)
Inventor: **Hummel, Peter**
Schllinkergarten 16
D-6465 Biebergemund-Wirtheim(DE)

74 Representative: **Fry, Alan Valentine**
FRY, HEATH & CO., St. Georges House 6
Yattendon Road
Horley Surrey RH6 7BS(GB)

54 Improvements in or relating to darts.

57 A dart capable of being used either with a conventional dartboard or an electronic board includes a barrel which carries or is adapted to carry at one end a shaft capable of receiving a flight and is formed at its other end with means by which a point-carrying extension piece can selectively be connected to or disconnected from the barrel. The barrel end may be formed with an internally threaded bore for receiving a threaded member protruding from one end of each of at least two individual point-carrying extension pieces, one such extension piece carrying a metallic point and an other extension piece carrying a non-metallic point.

EP 0 367 558 A2

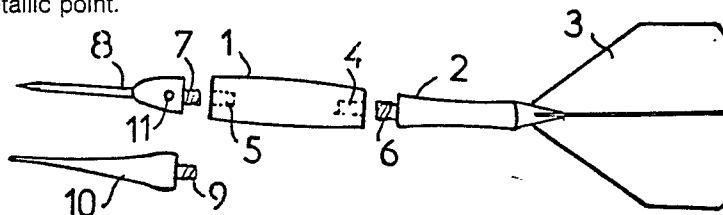

FIG. 1

Improvements in and Relating to Darts

This invention relates to darts.

Conventionally darts comprise a metal point fixed permanently to a barrel, a shaft connected to the barrel at its end remote from the point, and a flight. Whereas such darts can be used when playing with conventional dartboards, they cannot be used for electronic dartboards which comprise a multiplicity of individual apertures each capable of receiving a plastics pointed dart and each connected electronically to activate one of a plurality of electronic circuits to record, for example, the score achieved by a dart entering that aperture and the total score of the player making that throw.

In one aspect the present invention sets out to provide a dart or set of darts capable of being used either with a conventional dartboard or an electronic board. In another aspect, the present invention sets out to provide a dart or set of darts whose point, weight and/or length can selectively be changed.

According to the present invention in one aspect there is provided a dart which includes a barrel which carries or is adapted to carry at one end a shaft capable of receiving a flight and is formed at its other end with means by which a point-carrying extension piece can selectively be connected to or disconnected from the barrel, the said other barrel end being formed with an internally threaded bore for receiving a threaded member protruding from one end of each of at least two individual point-carrying extension pieces, one such extension piece carrying a metallic point and an other extension piece carrying a non-metallic point.

The non-metallic point is preferably a plastics (e.g. a nylon) material.

The metallic point carrying extension piece may be formed with a through aperture capable of receiving a lever to assist turning and tightening of the extension piece with respect to the barrel. In practise, the lever may comprise the point of another dart. The barrel is preferably a "soft-tip" barrel and is preferably constructed from a nickel/tungsten, nickel/silver alloy or from brass. The metallic point is preferably manufactured from steel.

In an alternative arrangement, the several point-carrying pieces are of different weights and/or lengths to one another. In this arrangement, the points carried by the extension pieces may all be of the same material or of different materials.

According to the present invention in another aspect there is provided a dart comprising a barrel formed at one end with a threaded bore capable of receiving selectively one of several point-carrying extension pieces, each extension piece being

formed with a threaded member protruding from its end remote from the point carried thereby. The several point carrying extension pieces may each be of different weight and/or length to the other such extension pieces.

In a still further aspect, the invention provides a barrel for a dart which includes at one end means capable of removably attaching to the barrel a point-carrying extension piece. The barrel may include at its other end means capable of removably attaching a flight-carrying shaft.

The invention will now be described by way of example with reference to the accompanying diagrammatic drawings in which:-

Figure 1 is an exploded view of a dart in accordance with the invention; and

Figure 2 illustrates an alternative dart in accordance with the invention.

As will be seen from Figure 1 of the drawings, a dart in accordance with the invention comprises an elongate soft-tipped barrel 1, a shaft 2 and a flight 3. The barrel 1 is formed at its end adjacent the shaft 2 with a threaded bore 4 and at its end remote from the shaft with a threaded bore 5. The shaft 2 includes at one end a threaded shank 6 which screws into the threaded bore 4 of the barrel and is formed at its other end with slots to receive the flight 3.

The threaded bore 4 of the barrel 1 complements a threaded shank 7 of a steel point-carrying extension piece 8 and a threaded shank 9 of a plastics point-carrying extension piece 10.

The plastics point may be produced from any suitable material, including nylon.

Thus, the dart is capable of being used selectively either with a conventional dartboard, (in which case the extension piece 8 would be used) or an electronic board (in which case the extension piece 10 would be used). Additionally or alternatively, the barrel 1 is capable of receiving selectively extension pieces having different weights and/or lengths to suit the preference of the user.

The weight and/or length of the extension pieces may be varied to suit any particular player. Thus, the weight of the extension piece 8 may be 5 grammes, 6 grammes, 7 grammes, 8 grammes, 9 grammes or 10 grammes, the respective lengths of the extension pieces being 16mm, 18mm, 20mm, 22mm, 24mm or 26mm. As illustrated the extension piece 8 is constructed of a nickel/tungsten 80/20 alloy. Alternatively, the extension piece 8 may be produced from a nickel/silver alloy or of brass.

The extension piece 8 includes a through-aperture 11 to enable a lever to be inserted thereth-

rough to ensure that the extension piece is firmly screwed onto the front end of the barrel 1 of the dart. The lever, in practise, may simply be the point of another dart.

The dart illustrated in Figure 2 is similar to that illustrated in Figure 1 excepting that the shape of the barrel extension piece 8 is different. In this particular embodiment, the weight of the extension piece may be 8 grammes, 10 grammes, 12 grammes, 14 grammes, 16 grammes or 18 grammes and the respective lengths maybe 14mm, 15.5mm, 17mm, 18.5mm, 20mm or 21.5mm. The diameter of each extension piece is approximatly 8mm.

It will be appreciated that the foregoing is merely exemplary of two embodiments in accordance with the invention and that modifications can readily be made thereto without departing from the true scope of the invention.

from the point carried thereby.

8. A dart as claimed in Claim 7 characterised in that the several point-carrying extension pieces are each of different weight and/or length.

Claims

1. A dart which includes a barrel (1) which carries or is adapted to carry at one end a shaft (2) capable of receiving a flight (3) and is formed at its other end with means by which a point-carrying extension piece (8) can selectively be connected to or disconnected from the barrel, the dart being characterised in that the said other barrel end is formed with an internally threaded bore (5) for receiving a threaded member (7) protruding from one end of each of at least two individual point-carrying extension pieces (8), one such extension piece (8) carrying a metallic point and another extension piece (10) carrying a non-metallic point.

2. A dart as claimed in Claim 1 characterised in that the non-metallic point (10) is a plastics material.

3. A dart as claimed in Claim 1 characterised in that the metallic point carrying extension piece (8) is formed with a through aperture (11) capable of receiving a lever to assist turning and tightening of the extension piece with respect to the barrel.

4. A dart as claimed in Claim 1, 2 or 3 characterised in that the barrel (1) is constructed from a nickel/tungsten, nickel/silver alloy or from brass.

5. A dart as claimed in any of Claims 1 to 4 characterised in that the metallic point (8) is preferably manufactured from steel.

6. A dart as claimed in Claim 1 characterised in that several point-carrying pieces are provided, each being of different weight and/or length.

7. A dart characterised by a barrel formed at one end with a threaded bore capable of receiving selectively one of several point-carrying extension pieces, each extension piece being formed with a threaded member protruding from its end remote

5

10

15

20

25

30

35

40

45

50

55

3

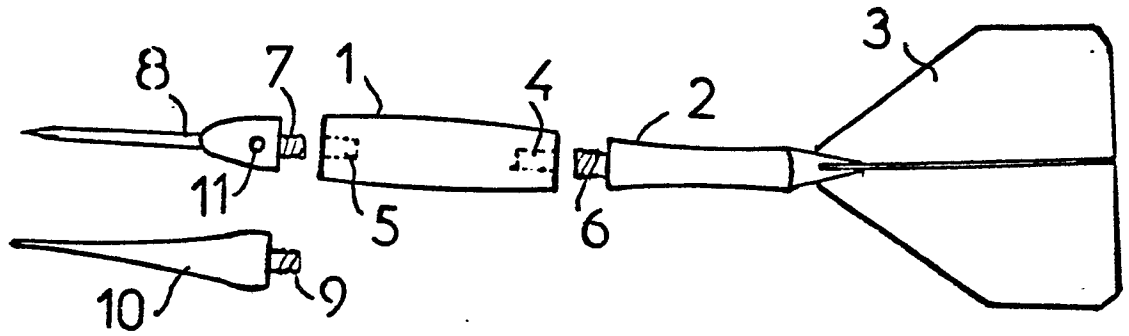

FIG. 1

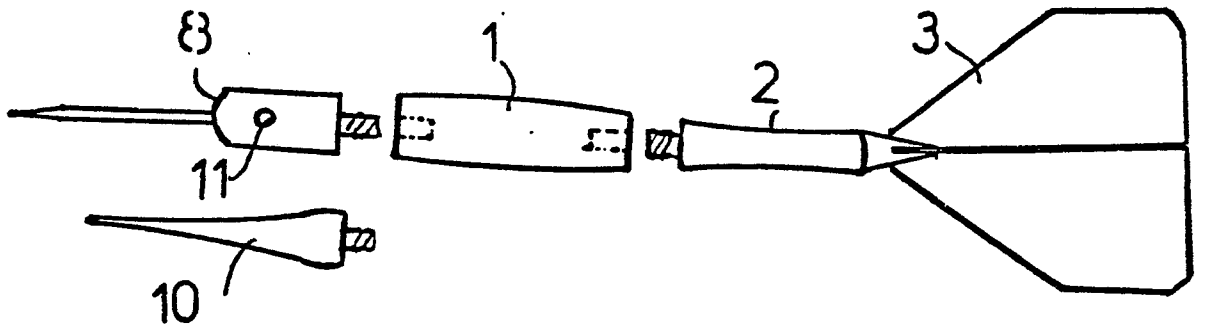

FIG. 2