

(19) World Intellectual Property Organization  
International Bureau



(43) International Publication Date  
28 September 2006 (28.09.2006)

PCT

(10) International Publication Number  
WO 2006/101802 A2

- (51) International Patent Classification:  
E04B 7/08 (2006.01)
- (21) International Application Number:  
PCT/US2006/008908
- (22) International Filing Date: 13 March 2006 (13.03.2006)
- (25) Filing Language: English
- (26) Publication Language: English
- (30) Priority Data:  
11/080,325 15 March 2005 (15.03.2005) US
- (71) Applicant and  
(72) Inventor: SALLES, Jaime, JR., C. [US/US]; 42 Lounsbury Road, Croton On Hudson, New York 10520 (US).
- (74) Agent: COPLIT, James, G.; Grimes & Battersby, LLP, 488 Main Avenue, Third Floor, Norwalk, CT 06851 (US).
- (81) Designated States (unless otherwise indicated, for every kind of national protection available): AE, AG, AL, AM,

AT, AU, AZ, BA, BB, BG, BR, BW, BY, BZ, CA, CH, CN, CO, CR, CU, CZ, DE, DK, DM, DZ, EC, EE, EG, ES, FI, GB, GD, GE, GH, GM, HR, HU, ID, IL, IN, IS, JP, KE, KG, KM, KN, KP, KR, KZ, LC, LK, LR, LS, LT, LU, LV, LY, MA, MD, MG, MK, MN, MW, MX, MZ, NA, NG, NI, NO, NZ, OM, PG, PH, PL, PT, RO, RU, SC, SD, SE, SG, SK, SL, SM, SY, TJ, TM, TN, TR, TT, TZ, UA, UG, US, UZ, VC, VN, YU, ZA, ZM, ZW.

(84) Designated States (unless otherwise indicated, for every kind of regional protection available): ARIPO (BW, GH, GM, KE, LS, MW, MZ, NA, SD, SL, SZ, TZ, UG, ZM, ZW), Eurasian (AM, AZ, BY, KG, KZ, MD, RU, TJ, TM), European (AT, BE, BG, CH, CY, CZ, DE, DK, EE, ES, FI, FR, GB, GR, HU, IE, IS, IT, LT, LU, LV, MC, NL, PL, PT, RO, SE, SI, SK, TR), OAPI (BF, BJ, CF, CG, CI, CM, GA, GN, GQ, GW, ML, MR, NE, SN, TD, TG).

Published:  
— without international search report and to be republished upon receipt of that report

For two-letter codes and other abbreviations, refer to the "Guidance Notes on Codes and Abbreviations" appearing at the beginning of each regular issue of the PCT Gazette.

(54) Title: DECORATIVE MODULAR TILE CLADDING SYSTEM AND METHOD

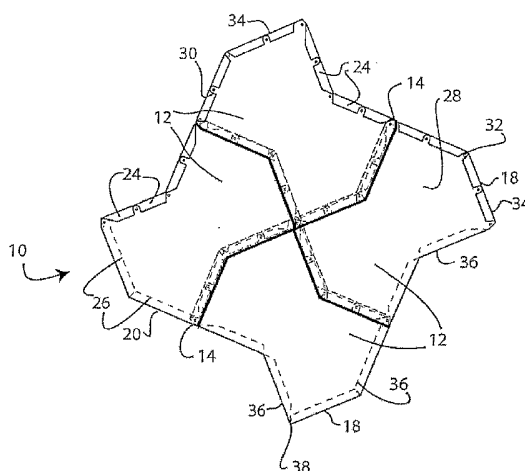

(57) Abstract: A decorative modular tile cladding system comprising a plurality of rectilinear or curvilinear polygonal tiles that include means for interlocking with each other to create a continuous "skin" that is used as cladding for exterior or interior surfaces of a structure. At least three separate means for interconnecting the tiles are contemplated: (1) folded tabs on each of the tiles that engage tabs on adjacent tiles to create a secure connection between tiles; (2) clips that are designed to engage the edges of adjacent tiles; (3) punched tabs or punched pockets to receive and engage a complementary tab. The tiles are attached to a standard sheathing substructure or substrate, and incorporate details for water, gas, and/or vapor exchange or expansion. In the preferred embodiment, the tiles are composed of metal, vinyl or plastic, although other materials are contemplated.

WO 2006/101802 A2

IN THE UNITED STATES PATENT & TRADEMARK OFFICE

PATENT APPLICATION

OF

JAIME C. SALLES, JR.

FOR

DECORATIVE MODULAR TILE CLADDING SYSTEM AND METHOD

TITLE: DECORATIVE MODULAR TILE CLADDING SYSTEM AND METHODBACKGROUND OF THE INVENTION1. Field of the Invention

The present invention relates generally to a decorative modular tile cladding system, and more particularly, to a decorative modular tile cladding system and method ideally suited for the exterior surfaces of buildings, and more particularly to a decorative modular tile cladding system comprising a plurality of tiles that include means for interlocking with each other to create a continuous "skin" that is used as cladding for the outside or inside surfaces of a residential or commercial structure or similar structure.

2. Description of the Prior Art

Systems for decorating and protecting the outer surfaces of buildings, particularly residential buildings, have long been known in the art. Examples of such systems include shingles, stucco, stone, brick and siding. The most common example of the latter method for covering and protecting the exterior surface of the structure are long extruded panels or elements of material such as vinyl or aluminum, which are installed in either a horizontal or vertical configuration on the sides of the structure. The benefit of such systems is that they are relatively easy to install and maintain, although they are not

necessarily the most aesthetically pleasing solutions. An example of a sheet metal siding system wherein the individual elements interlock with each other is disclosed in U.S. Patent No. 754,541, which issued to Charlebois on March 15, 1904 for "Sheet Metal Siding."

Another method that is somewhat similar to that of siding is cladding, wherein sheets of various textures and/or colors are applied directly to the exterior of the structure. In addition to plastics and vinyl, various other materials are available for cladding, including metal, cement and even glass, which afford a highly weather resistant substrate or skin. Unfortunately, the design choices for such materials, particularly metal, are quite limited, and provide an aesthetically inappropriate installation to design. Such systems are also not generally available for "off the shelf" applications, and require special equipment, tooling or training for installation.

While there exist systems in the prior art that utilize metal detailing and exterior cladding, such prior art references are quite limited. The current metal siding/cladding market breaks up into to several categories: (1) the industrial utilitarian approach, using corrugated sheet metal for roofs and metal walls; (2) the architectural, commercial, residential approaches where metal is used to replicate another siding form

(such as aluminum clapboard siding or metal plate type installations on commercial sites), which approach incorporates proprietary fabrication and support structures to enable installation, thereby necessitating the purchase of particular substructure/substrate to install; and (3) the pressed metal market that usually addresses interior ceiling and decorative wall motifs (e.g., turn of the century pressed tin ceiling). Other than some cast iron decorative metal elements, however, examples of the turn-of-the-century work are normally limited to interior installations.

There are various references in the prior art for cladding systems or similar systems for the creation of an external or internal "skin," wherein individual panels interlock with each other to create a single unit. For example, U.S. Patent No. 2,454,307, which issued to Cooley on November 23, 1948 for an "Interlocking Mosaic" discloses a structure composed of a plurality of interlocking members.

Systems for aligning or otherwise orienting tiles or other elements used in covering surfaces such as walls or floors have also been disclosed in the prior art. For example, U.S. Patent No. 2,490,577, which issued to Brown on December 6, 1949 for "Interlocking Wall Tile" teaches interlocking wall tiles having flanges for interconnecting adjacent tiles wherein a tab allows

for spacing and alignment for the installation of plastic wall tile.

It should be appreciated that the tiles used in such cladding or tiling systems need not be rectangular. For example, hexagonal tiles are disclosed in U.S. Patent No. 358,175, which issued to Thomas on February 22, 1887 for "Metallic Plate for Facing Walls." In fact, a wide variety of non-traditional patterns, geometries or designs may be contemplated for the individual panels or tiles of a cladding system, as suggested by U.S. Patent No. 4,133,152, which issued to Penrose on January 9, 1979 for "Set of Tiles for Covering a Surface."

The tiles in such systems need not be limited to installation on walls or exterior vertical surfaces. For example, U.S. Patent No. 5,584,592, which issued to Martin on February 3, 2004 for "Interlocking Floor Panels" discloses a tiling system having interlocking tiles for use as a portable floor for dancing or shows. Alternatively, the tiles or panels need not be attached to a pre-existing surface such as a wall or floor, but may in fact be used to create a free-standing structure or unit, as is disclosed in U.S. Patent No. 2,918,151, which issued to Kennedy on December 22, 1959 for "Self-Sustaining Building Unit and Wall."

It should also be appreciated that the cladding, tiling or siding system need not be two-dimensional in design or appearance. A variety of three-dimensional systems have also been developed, many of them for use in connection with roofs as well as on walls or floors. Examples include U.S. Patent No. 4,295,316, which issued to Carlson on October 20, 1981 for "Nestable Building Wall Panel"; U.S. Patent No. 4,930,282, which issued to Meadows on June 5, 1990 for "Architectural Tile"; and U.S. Patent No. 5,074,093, which issued to Meadows on December 24, 1991 for "Overlapping Architectural Tiles."

As shall be appreciated, the prior art fails to specifically address either the problem or the solution arrived upon by applicant.

SUMMARY OF THE INVENTION

Against the foregoing background, it is a primary object of the present invention to provide a decorative modular tile cladding system and method for installing same.

It is another object of the present invention to provide such a decorative modular tile cladding system that is manufactured of metal.

It is yet another object of the present invention to provide such a decorative modular tile cladding system that may be purchased off the shelf and easily installed with currently available installation tooling.

It is another object of the present invention to provide such a decorative modular tile cladding system that may be easily adapted to any installation.

It is but another object of the present invention to provide such a decorative module that is customizable to any application.

It is still another object of the present invention to provide such a decorative modular tile cladding system that is aesthetic as well as functional.

It is but another object of the present invention to provide such a decorative modular tile cladding system that allows for water run off.

It is yet another object of the present invention to provide such a decorative modular tile cladding system that utilizes an installation methodology that is invisible from the exterior.

It is but another object of the present invention to provide such a decorative modular tile cladding system that may include perforations to allow it to be mechanically attached to a standard sheathing substructure or other substrate with ease.

It is yet another object of the present invention to provide such a decorative modular tile cladding system that includes weep holes to permit the exchange of water, gas and vapor from behind the tile to the exterior.

It is still another object of the present invention to provide such a decorative modular tile cladding system that allows application on, and once applied lies flat on, any type of surface, including flat, convex and concave surfaces.

It is another object of the present invention to provide such a decorative modular tile cladding system that achieves a secure full perimeter for each modular tile.

It is yet another object of the present invention to provide such a decorative modular tile cladding system that allows for installation on a surface with a negative angle off vertical.

It is another object of the present invention to provide such a decorative modular tile cladding system that includes detailing for architectural perforations.

It is still another object of the present invention to provide such a decorative modular tile cladding system that can wrap around corners and other architectural features

(without breaking pattern), such as windows, doors, inside and outside corners, overhangs and other siding types where mixed siding use is contemplated.

It is another object of the present invention to provide such a decorative modular tile cladding system that requires no special structural underlayment.

It is yet another object of the present invention to provide such a decorative modular tile cladding system that may be applied to any type of structural underlayment, including special engineered substructures.

It is but another object of the present invention to provide such a decorative modular tile cladding system that uses off-the-shelf materials such as copper, brass, bronze, aluminum and/or steel sheet metal, and is adaptive to other materials, such as plastics, vinyls and composites.

It is another object of the present invention to provide such a decorative modular tile cladding system that allows for various expansion coefficients of different metals.

It is yet another object of the present invention to provide such a decorative modular tile cladding system that includes full perimeter interlocking and captured joints with true water management detailing.

It is still another object of the present invention to provide such a decorative modular tile cladding system that allows for intermixing colors and materials.

It is another object of the present invention to provide such a decorative modular tile cladding system that is affordable.

It is yet another object of the present invention to provide such a decorative modular tile cladding system that features off the shelf availability and opens the installation to semi-custom applications.

It is another object of the present invention to provide such a decorative modular tile cladding system that allows for many modularized tile designs and integration of different modular styles/designs.

It is but another object of the present invention to provide such a decorative modular tile cladding system that is truly decorative and functional in a new way and does not merely emulate and mimic traditional materials and methodologies like brick, stone, clapboard or vinyl siding.

It is still another object of the present invention to provide such a decorative modular tile cladding system that creates a whole new look from a design perspective with enhanced functional qualities as well.

It is another object of the present invention to provide such a decorative modular tile cladding system that features enhanced breathability over other siding systems.

It is but another object of the present invention to provide such a decorative modular tile cladding system that is easy to repair.

To the accomplishments of the foregoing objects and advantages, the present invention, in brief summary, is a decorative modular tile cladding system polygonal tiles that include means for interlocking with each other to create a continuous "skin" that is used as cladding for the side of a structure. The tiles may be rectilinear or curvilinear as desired. At least three separate means for interconnecting the tiles are contemplated, including: (1) folded tabs on each of the tiles that engage tabs on adjacent tiles to create a secure connection between tiles; (2) clips that are designed to engage the edges of adjacent tiles; and (3) punched pockets and punched tabs to receive and engage a complementary tab. The tiles may be attached to a standard sheathing substructure or substrate, regardless of the shape or size of the structure to which the tiles are being attached, including curved surfaces, and incorporate details for water/gas/vapor exchange, as well as expansion. In the preferred embodiment, the tiles are composed of metal or plastic, although other materials are contemplated.

BRIEF DESCRIPTION OF THE DRAWINGS

The foregoing and still other objects and advantages of the present invention will be more apparent from the detailed explanation of the preferred embodiments of the invention in connection with the accompanying drawings, wherein:

FIG. 1 is a top plan view of the decorative modular tile cladding system of the present invention;

FIG. 2 is a top plan view of the left handed and right handed tiles of the decorative modular tile cladding system of FIG. 1;

FIG. 3 is a top plan view of the decorative modular tile cladding system of the present invention showing various elements thereof in closer detail;

FIGS. 4A-4C are top plan views of the decorative modular tile cladding system of the present invention using clips for attachment of adjacent tiles;

FIGS. 5A-5C are top plan views of the decorative modular tile cladding system of the present invention using folded fingers in place of folded tabs for attachment of adjacent tiles;

FIG. 6A-6C are cutaway side views showing the installation of the decorative modular tile cladding system of the present invention;

FIG. 7A-7C are cutaway side views showing the water management system of the decorative modular tile cladding system

of the present invention and comparing said installation to the installation of an another siding system;

FIGs. 8-8B are perspective illustrations showing the installation of the decorative modular tile cladding system of the present invention and the various solutions used for addressing architectural elements such as corners and windows;

FIGs. 9-13 are top plan views of various tile fields of the decorative modular tile cladding system of the present invention;

FIG. 14 is an illustration of the rules governing orientation and placement of the pockets, tabs, clips and weep holes of the decorative modular tile cladding system of the present invention.

Figs. 15A-15C are top plan views of the decorative modular tile cladding system of the present invention using Punched Tabs with an extended tile shape.

Figs. 16A-16C are top plan views of the decorative modular tile cladding system of the present invention using Punched Pockets with an extended tile shape.

BRIEF DESCRIPTION OF THE PREFERRED EMBODIMENTS

Referring to the drawings and, in particular, to Figs. 1-3 thereof, the decorative modular tile cladding system of the present invention is provided and is referred to generally by reference numeral 10. The decorative modular tile cladding system 10 comprises a plurality of rectilinear polygonal tiles 12 which in the preferred embodiment are manufactured from metal, such as copper, brass, bronze, aluminum and/or steel sheet metal.

Alternatively, other materials may be used, such as vinyl or plastic, or composites, which materials will have a different aesthetic than the metal tiles 12, but may be far less expensive to manufacture and may be easier to install. It should also be appreciated that although in the preferred embodiment the tiles 12 are rectilinear, there are an unlimited number of shapes and configurations that would be just as effective, including curvilinear shapes.

The tiles 12 include interlocking means 14, which allow adjacent tiles 12 to be interconnected to thereby create a continuous "skin" that may be used as cladding for the side of a structure, either externally or internally. Alternatively, the cladding may be used on a floor or even a ceiling of the structure, although the water management feature of the system would not be implemented in such use. In the preferred embodiment, the interlocking means 14 comprise at least one folded

tab 16 on at least one edge 18 of the tile 12, which folded tabs 16 engage the folded tabs 16 on adjacent tiles 12 to create a secure connection, wherein the entire surface created thereby becomes an interconnected breathable "skin." The folded tabs 16 allow the full perimeter 20 of the tiles 12 to be self sealing, with the design features of interlocking means 14 allows for both edges to be captured and anchored yet free to move, thereby giving the individual tiles 12 room for thermal expansion and contraction while being completely attached to the substructure 21, whether such substructure be sheathing, substrate, specially engineered substructure such as concrete or steel, or other materials or systems.

In the preferred embodiment, each tile 12 is of the same shape and size, and includes weep holes 22 that facilitate the management of water 23 by the tiles 12. In such embodiment, two types of folded tabs 16 are provided on each tile 12 - a top folded tab 24 and a bottom folded tab 26. The top folded tab 24 is characterized by a tab 16 that is folded down and over the upper surface 28 of the tile 12. The top folded tabs 24 include a notch 30, which notch corresponds to one or more holes 32 that may be disposed along the top leading edge 34 of the tile face 28, which holes 32 are provided to allow for fasteners such as screws to be installed along the top leading edge 34 of the tiles 12. It should be appreciated that the holes 32 are not necessary

to the installation of the cladding system 10 inasmuch as nails or self-tapping screws may be used to pierce the tiles 12 if no holes 32 are provided. However, the notches are spaced appropriately for the attachment of these types of fasteners. It should also be appreciated that the unique interlocking structure of the decorative modular tile cladding system 10 ensures that the fasteners will not be visible when the tiles 12 are installed due to the overlapping tabs 24, 26.

The bottom folded tabs 26 are provided along the bottom edge 36 of the tiles 12, said bottom folded tabs 26 being characterized by a tab 16 that is folded under the tiles 12 such that they would be facing the substrate when the tile 12 is applied to the wall. Adjacent tiles 12 are attached by sliding the edge of tab 26 of one tile 12 under and into the top edge 34 of the adjacent tile such that the bottom folded tab 26 engages the top folded tab 24 or pocket of the tile 12 or tiles 12 beneath it. As illustrated in the various Figures showing the different configurations of the tiles 12, each tile 12 is thereby secured and fastened on all edges 18 thereof. A detailed illustration of the interlocking means is shown in FIGs. 6A-6B-6C. In such illustrations, the interaction of the top folded tab 24 and the bottom folded tab 26 is highlighted, as is the fact that the tiles 12 also serve to hide the fastener when installed.

It should be appreciated that in the preferred embodiment, the tabs 16 are designed so they do not exactly meet at the corners 38, allowing for vapor and water respiration and escape.

Another aspect of the water management of the decorative modular tile cladding system 10 of the present invention are the weep holes 22, which features prevent the collection or pooling of water 23 or other fluids in the folds 16 of the tiles 12. As illustrated in FIGs. 7A-7C, the weep holes 22 located along the bottom folded tabs 26 allow for rain water, condensation and other fluids and gases to pass through and not collect in the wells 39 created by the folded tabs 24, 26. In fact, these weep holes 22 allow for water that condenses along the back surface 29 of the tiles 12 to escape, thereby preventing any damage to the tiles 12 or to the substructure 21 upon which the tiles 12 are installed. A comparison of the water management feature of the present invention is illustrated in FIGs. 7A and 7B, with FIG. 7A detailing the water management of the siding system of Thomas (U.S. Patent No. 358,175) wherein the water 23 is allowed to pool, and the water and vapor management of the cladding system 10 of the present invention being shown in FIG. 7B.

It has been observed that, depending on the modular design of the tiles 12, two or more types of tiles 12 may be required to make up the decorative modular tile cladding system 10 of the present invention, although certain designs may only require one

type of tile 12. As illustrated in Figure 2, one of the embodiments of the present invention requiring two types of tiles 12 is shown, wherein these two types can generally be described as a "right handed" tile 40 and a "left handed" tile 42, with each having a design that mirrors the other for use at different ends of the surface. In addition to being mirror images, the tiles 40, 42 may also be different rotations or flipped versions of the same design. Alternatively, the two tiles 40, 42 may be entirely different in size or orientation.

Termination elements 44 and edge detailing strips 46 may also be provided, which objects are designed to allow attachment of cut ends 48 of the tile field 50 defined by the interconnected tiles 12 as it is terminated or otherwise impacted by the architectural elements, corners or edges of the structure. Other folded elements may also be provided for the system 10, including drip edges 52 and boundary/edge trim 54. It should be appreciated that these elements are merely for illustrative purposes only, as a number of additional design features are anticipated.

The installation of the decorative modular tile cladding system 10 of the present invention is as easy as the installation of current off-the-shelf siding systems, and uses similar tools, although the technique and process of coverage is fundamentally

different, particularly with respect to dealing with edges and wrapping around corners. As has already been discussed, the system 10 is designed to be installed directly onto any type of substructure 21, including standard sheathing such as a normal ½" plywood sheathing substrate covered with an appropriate water and vapor barrier such as tarpaper. Each tile 12 is captured using a fastening device such as a screw or appropriately rated nail, such as a 6 flat-headed pan screw, on the top edge 34 in the appropriate holes 32 or alternatively without the need for holes 32, provided that the fasteners pierce the tiles 12 at the provided notch 30 or fastening protocol, and will be covered by the folded tab 16 so as to hide them from view when the cladding system is completely installed, and follow specific layout pattern to be provided depending on tile specs. As tiles 12 are laid into each other, the bottom folded tab 26 captures half of the top folded tabs 24 of the two tiles 12 directly below it. Special beginning and termination tiles can also be provided (or created on site) depending on site needs. Tiles 12 are laid from the bottom up in the opposite direction of water flow.

In an alternative embodiment, clips 56 may be provided to engage the edges 18 of adjacent tiles 12. In yet another alternative embodiment, fingers 58 may be used instead of tabs 16, which fingers 58 may be cut so as to create the notch 30 for example, and which may also be folded in much the same way as tabs

16. In the embodiment wherein fingers 58 are used in place of tabs 16, the need to notch out tabs when tile 12 installation is conforming to a corner or other architectural feature is eliminated, thereby facilitating the preparation of the tiles 12 for installation on site. The tile 12 can also be bent without notching the bottom folded tab 26 or top folded tab 24. It should be appreciated that in this embodiment, it is preferable to orient the finger 58 parallel to the vertical axis, or alternatively to the plumb of the design of the tile field 50. The corresponding finger 58 may be pre-notched for access to hole 32 or in determining fastening pattern/protocol. Finally, in such embodiment, if the tile 12 is folded around a corner, only the finger tabs 58 in the area of the fold will deform, precluding the need to notch the tabs 58 when making a bend during installation.-

Illustrated in FIGs. 9 through 13 are some of the variations of tile fields 50 that may be created using the decorative modular tile cladding system 10 of the present invention. These variations are provided for illustrative purposes only, and should not be construed as limiting the potential designs or configurations of the tiles 12. It should be appreciated that in some of these configurations, more than a right tile 40 and left tile 42 are utilized, as shown in FIGs. 12 and 13.

FIG. 14 illustrates a protocol by which the folded tabs 16 are oriented and placed on the tile 12. The joint protocol establishes the determination of an over edge 60 and under edge 62 to the geometric pattern of the tile 12, allowing the tiles 12 to be overlapped and secured. The overlap and layout of the two folds 64 that comprise one segment 66 connection is determined by the orientation of each segment 66 of the geometric pattern to the vertical axis. By drawing a bounding box 70 around the anchor points 72 to each segment 66, one can readily determine which area is above and below the segment 66. The tile 12 comprising the area above the segment 66 receives a backward fold 74 and the tile that comprises the lower area of the segment receives a forward fold 76 to create the leading edge 34, a punched pocket or punched tab.

The backward fold 74 has a length equal to the segment 66 with edges 18A tapered inward and a depth slightly shorter than the corresponding forward facing fold 76, a weep hole 22 detail at the meeting points of the segments 66 where two folds 74 meet, not to extend into to the forward face 28 to allow for the release of surface water and migration of condensate water 23 that may form in the boundary layer between the cladding and the substructure 21. In the embodiment having fingers 58, the backwards fold 74 is similarly formed from extension 78 and subdivided into fingers 58.

The forward fold 76 is formed from forward fold extension 78A which is approximately twice the tab depth which is folded over itself in half to meet tile face 28. Notches 30 and hole 32 are punched into the fold 76 corresponding to fastener placement in one embodiment. In still another embodiment, wherein the fingers 58 subdivide the tab 16 allowing for vertical bending of the tile 12 without cutting the fold 64 on corner bends during installation, forward folds 76 is similarly formed from extension 78A, wherein said extension 78A is subdivided to form fingers 58.

In the embodiment using clips 58 (Embodiment 2), the area below segment 66 does not receive a fold 64, but merely includes extension 78, and clips 58 slide over this extension 78 and are captured with fasteners through the tile 12. In yet another embodiment, a punched pocket or punched tab is forged on the blank and aligned to the pattern of tiles 12 and of the same depth as the slightly smaller of the corresponding backwards tab 74.

In the preferred embodiment, installation of the cladding system 10 is commenced by attaching a fold strip 80 to the substructure 21 to capture the starting tile 12 course, and a drip edge 52 detail finish, and subsequent tiles 12 are fastened in series in an upward direction. A tile 12 is slid up such that

its bottom folded tab 26 engages the top folded tab 24 of the fastened bottom course of tiles 12. The tile 12 is thereafter fastened to the substructure 21 along the top edge 34, with or without clips 58. As the tile field 50 reaches a corner, the tile 12 is marked to the corner and bent and the installation proceeds. It should be realized that the tile field 50 need not bend on the tile pattern's 50 geometric axis. On any edges 18 that terminate the pattern, a fold strip 44 is nailed and the tile 12 is captured thereby.

In yet another embodiment of the present invention, as illustrated in FIGs. 15A-16C, punched tabs 82 or punched pockets 84 are used in place of some of the folded tabs 16. In the creation of a punched tab 82 or punched pocket 84, the blank tile 12 may take an extended shape 86 incorporating the uppermost horizontal level encompassed by the geometric shape of the tile 12.

The extended shape 86 derives its outline on the left by taking on the left most edge of the left-most bounding box 70 used in determining left most edge 60. The outline on the right is similarly determined by taking on the right most edge of the right most bounding box 70 used in determining the right most edge 60. Finally, the extended shape 86 derives its uppermost

boundary by taking on the top most edge of the top most bounding box 70 used in determining the top most edge 60.

In this embodiment when creating a bottom fold 26 under the edge 62, the folds are determined by the shape of the tile 12 of the intended system 10 as bottom edge 36 conforms to the geometric pattern. The punched tab 82 or punched pockets 84 are machined slightly away and in a pattern that follows the tile 12 position of the upper edge formed by the pattern 12.

In the preferred embodiment, the overall outline of the extended shape 86 will remain true to the top most outline and thus form a dependable registration outline for the installation procedure and facilitate the alignment of the pattern and its feature set correctly on the structure during installation. It should be appreciated, however, that certain tile patterns may make it advantageous to strictly adhere to the right, left, top or any combination in determining the tile's 12 outline in setting up the coordinate system. This will allow a vertical or horizontal registration protocol to be established. By transferring the corresponding registration protocol on the intended structure, a correct alignment and spacing of the installation of the tile field 50 may be facilitated.

In the case of a repair where a damage tile is removed, this embodiment provides the anchoring for the repair tile 12 to capture the installed punched pockets 84. The repair tile 12 that will take a slightly new form or protocol therefore has access to the established hidden anchoring mechanism and can readily engage the tile 12 above it.

Finally, an added feature of this embodiment is that the resulting opening in the extended shape 86 tile face 28 results in openings that are situated directly behind and above the overlapping tile 12 above it allowing protection from the environment but increasing the vapor exchange and heat transfer exchange from behind the tile field 50.

Of course, it should be appreciated that any combination of the systems and methods taught herein may be utilized in one tile.

Having thus described the invention with particular reference to the preferred forms thereof, it will be obvious that various changes and modifications can be made therein without departing from the spirit and scope of the present invention as defined by the appended claims.

WHEREFORE, I CLAIM

1. A decorative modular tile cladding system for covering a surface and for conforming to any contours on said surface, said system comprising a plurality of polygonal tiles each including means for interlocking with each other so as to create a continuous and uninterrupted covering that may easily be modified to accomodate architectural elements on said surface, wherein said tiles are designed in a first and second complementary configuration such that a tile of said first configuration is interlocked with a tile of said second configuration.

2. The decorative modular tile cladding system of claim 1, wherein said tiles include outer edges and said means for interlocking comprises two or more folded tabs disposed along said outer edges.

3. The decorative modular tile cladding system of claim 2, wherein said tiles include top edges and bottom edges, and wherein said folded tabs include top folded tabs disposed along said top edges and bottom folded tabs disposed along said bottom edges.

4. The decorative modular tile cladding system of claim 3, wherein said tiles include an upper surface and a lower surface,

and wherein said top folded tabs are folded over said upper surface and said bottom folded tabs are folded back against said lower surface such that said upper folded tab engages said lower folded tabs on adjacent tiles.

5. The decorative modular tile cladding system of claim 4, wherein said top folded tab includes a notch therein.

6. The decorative modular tile cladding system of claim 5, wherein said tiles include a top leading edge and further wherein at least one hole is disposed along said top leading edge, said hole being adapted to receive a fastener, wherein said hole corresponds to said notch when said top folded tab is folded against said upper surface.

7. The decorative modular tile cladding system of claim 3, further including weep holes provided along said bottom folded tabs to allow fluids and vapors to pass through said system.

8. The decorative modular tile cladding system of claim 2, wherein said tabs do not meet in flush alignment, thereby allowing fluids and vapors to pass through said system.

9. The decorative modular tile cladding system of claim 1, wherein said tiles are composed of a material that may easily be cut and shaped.

10. The decorative modular tile cladding system of claim 9, wherein material is selected from the group consisting of metal, vinyl and plastic.

11. The decorative modular tile cladding system of claim 1, wherein said tiles may be cut, and further including edge detailing strips for providing an aesthetically pleasing and architecturally sound cover for cut portions of said tiles.

12. The decorative modular tile cladding system of claim 1, further including drip edges and boundary trims.

13. The decorative modular tile cladding system of claim 1, wherein said surface includes corners, and wherein said tiles are adapted to be bent around said corners to thereby provide a continuous and uninterrupted cover.

14. The decorative modular tile cladding system of claim 1, wherein said surface includes corners and architectural elements, and wherein said tiles are adapted to be cut to fit around said corners and said architectural elements to thereby provide a

continuous and uninterrupted cover, and wherein said system further includes detailing elements to cover and dress said cut tiles.

15. The decorative modular tile cladding system of claim 1, wherein said first configuration and said second configuration are identical.

16. The decorative modular tile cladding system of claim 1, wherein said tiles include an extended upper surface and bottom edges having a bottom pattern, and wherein bottom folded tabs are disposed along said bottom edges and wherein at least one punched tab is provided in said extended upper surface such that said punched tabs conform to receive said bottom pattern.

17. The decorative modular tile cladding system of claim 1, wherein said tiles include an extended upper surface and bottom edges having a bottom pattern, and wherein bottom folded tabs are disposed along said bottom edges and wherein at least one punched pocket is provided in said extended upper surface such that said punched tabs conform to said bottom pattern and further wherein the shape of said punched pocket conforms to receive said bottom folded tabs.

18. The decorative modular tile cladding system of claim 16 or 17, wherein said first configuration and said second configuration are identical.

19. A decorative modular tile cladding system for covering a surface and for conforming to any contours on said surface, said system comprising a plurality of polygonal, metal tiles each including top edges, bottom edges, an upper surface, a lower surface, and means for interlocking with each other so as to create a continuous and uninterrupted covering that may easily be modified to accommodate architectural elements on said surface, wherein said tiles are designed in a first and second complementary configuration such that a tile of said first configuration is interlocked with a tile of said second configuration, wherein said means for interlocking comprises two or more folded tabs disposed along said outer edges, and wherein said top folded tabs are folded over said upper surface and said bottom folded tabs are folded back against said lower surface such that said upper folded tab engages said lower folded tabs on adjacent tiles.

20. The decorative modular tile cladding system of claim 19, wherein said first configuration and said second configuration are identical.

21. A method for installing a decorative modular tile cladding system for covering a surface and for conforming to any contours on said surface, said method comprising the steps of:

providing a plurality of polygonal tiles each including means for interlocking with each other so as to create a continuous and uninterrupted covering that may easily be modified to accommodate architectural elements on said surface, wherein said tiles are designed in a first and second complementary configuration such that a tile of said first configuration is interlocked with a tile of said second configuration

attaching a tile of said first configuration to said surface using a fastener;

interlocking a tile of said second configuration to said attached tile of said first configuration;

attaching said tile of said second configuration to said surface; and

repeatedly interlocking and attaching tiles of said first configuration and said second configuration to thereby cover said surface.

22. The method of claim 21, further including the step of first attaching a fold strip to said surface, wherein said fold strip includes means for interlocking with said tiles and wherein a first row of tiles is installed along said fold strip.

23. The method of claim 22, wherein said tiles include an extended surface and bottom edges having a bottom pattern, and wherein bottom folded tabs are disposed along said bottom edges and wherein at least one punched tab is provided in said extended surface such that said punched tabs conform to receive said bottom pattern, further including the step of repairing said covering by removing a damaged tile and seamlessly replacing said damaged tile with a repair tile.

24. The method of claim 22, wherein said tiles include an extended upper surface and bottom edges having a bottom pattern, and wherein bottom folded tabs are disposed along said bottom edges and wherein at least one punched pocket is provided in said extended upper surface such that said punched tabs conform to said bottom pattern and further wherein the shape of said punched pocket conforms to receive said bottom folded tabs, further including the step of repairing said covering by removing a damaged tile and seamlessly replacing said damaged tile with a repair tile.

Fig 1

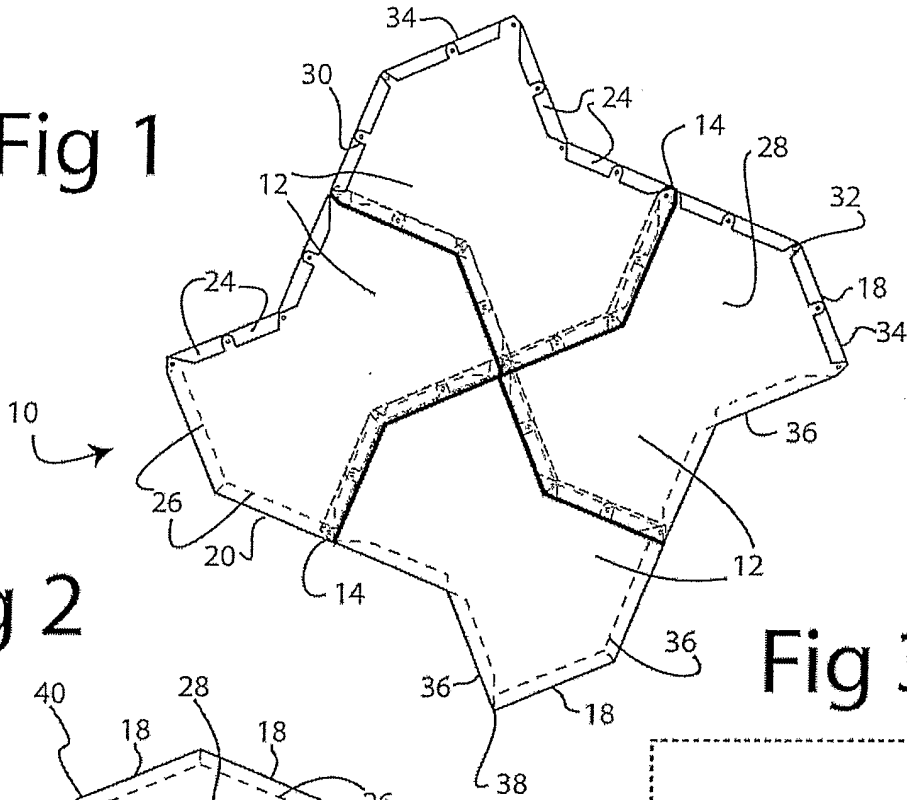

Fig 2

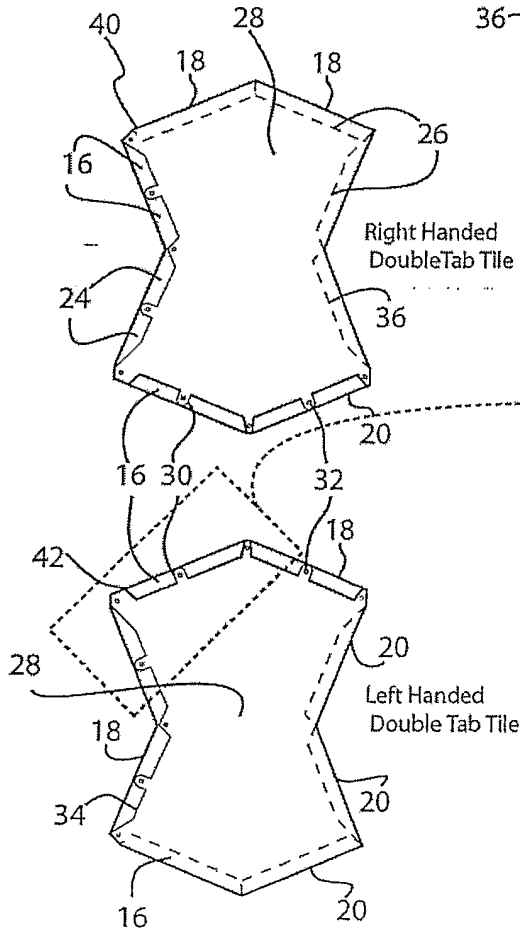

Fig 3

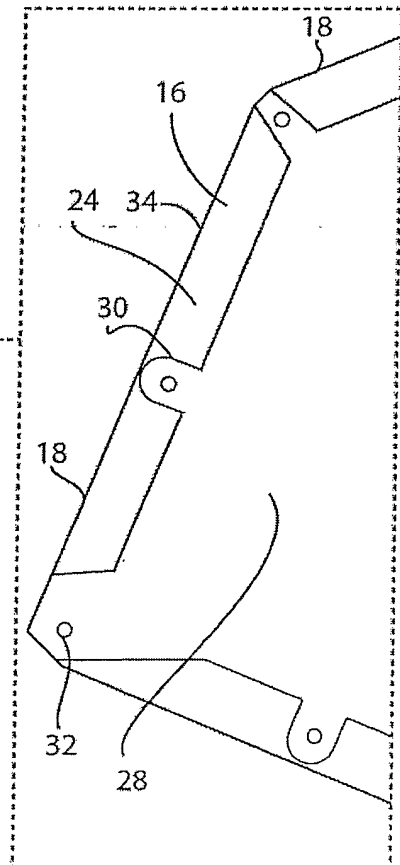

Fig 4A

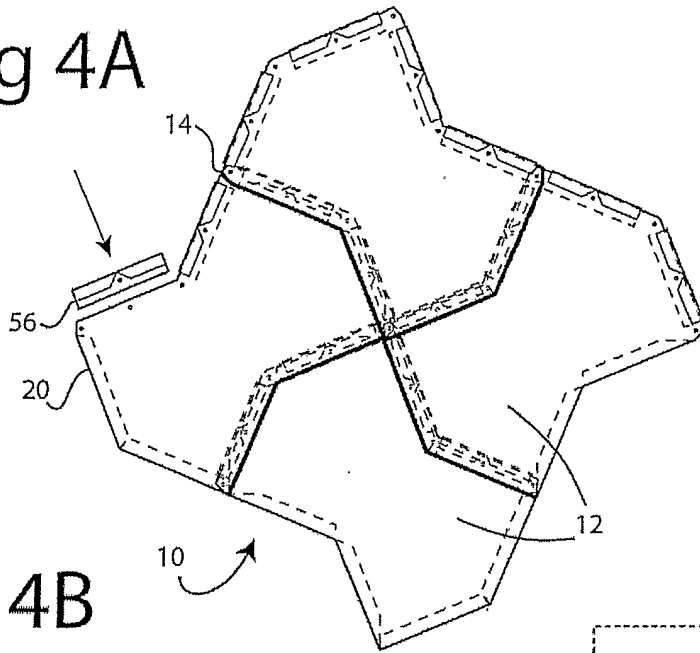

Fig 4B

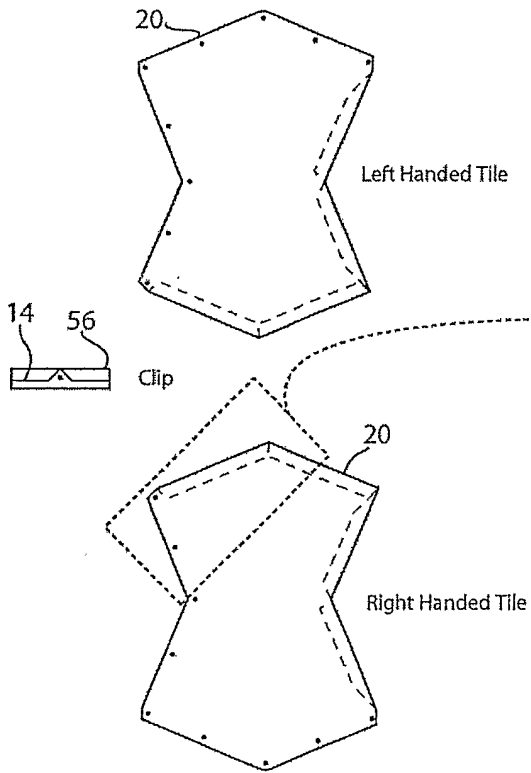

Fig 4C

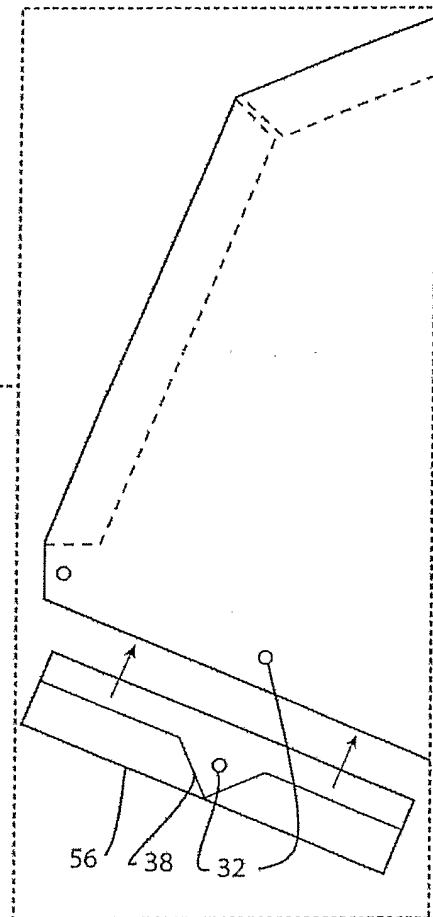

Fig 5A

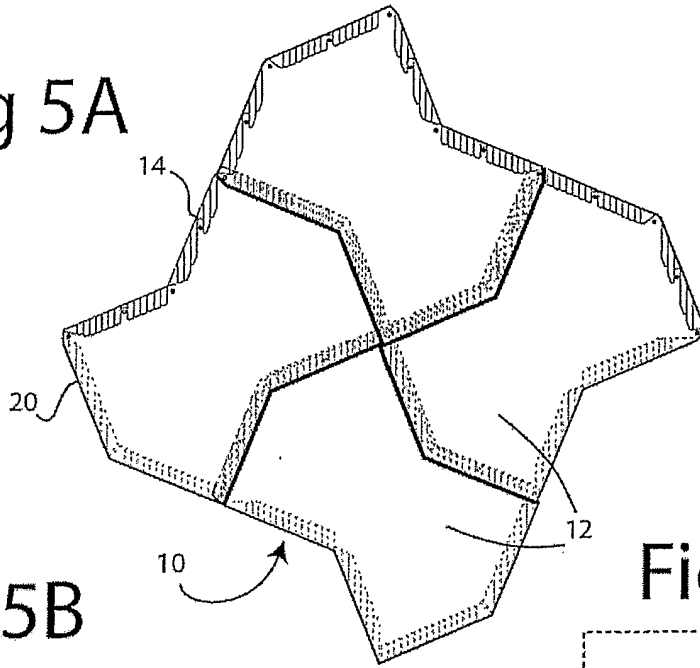

Fig 5B

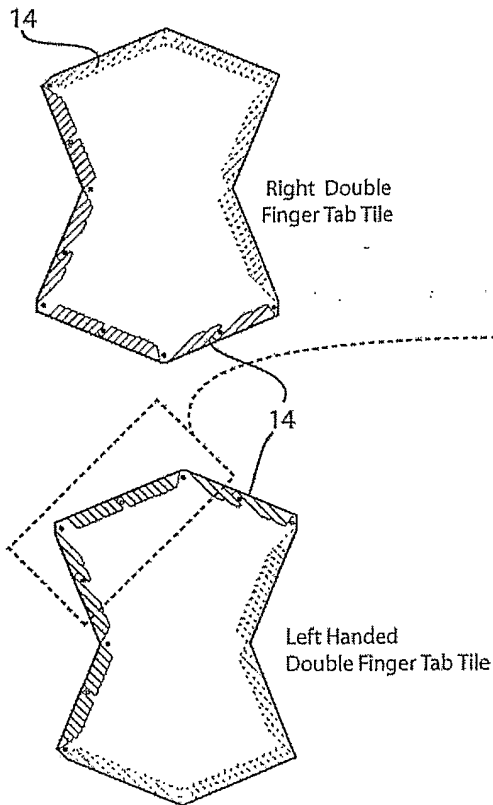

Fig 5C

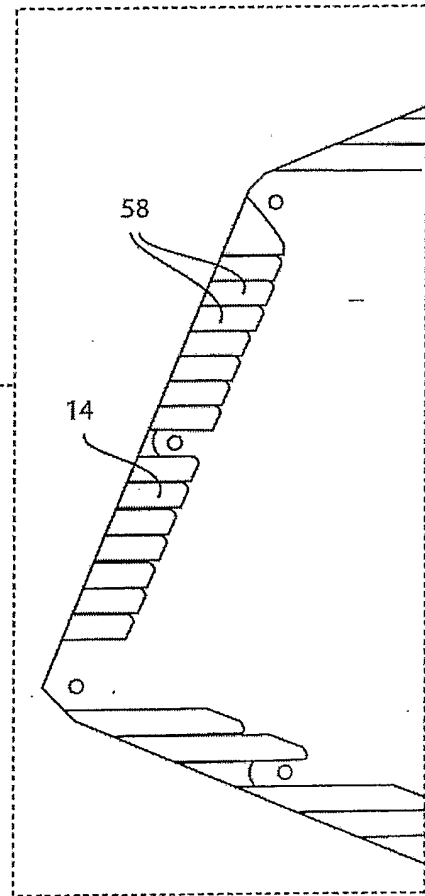

Fig 6A

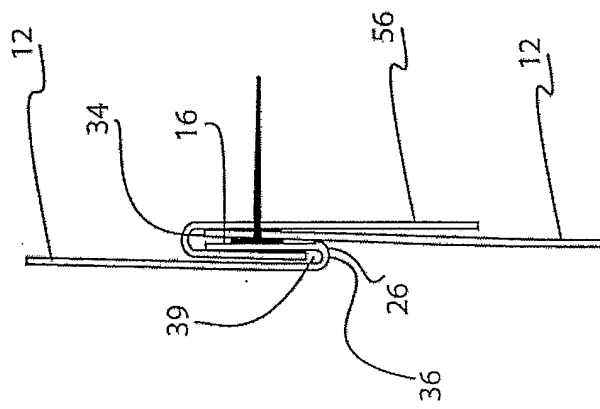

Fig 6B

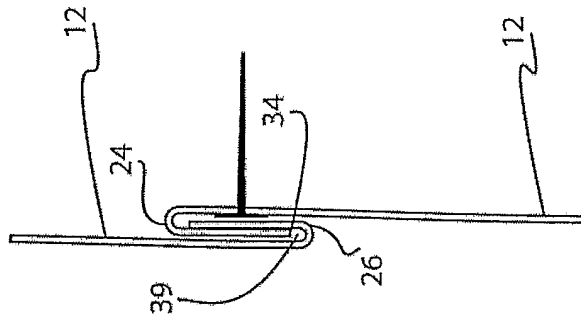
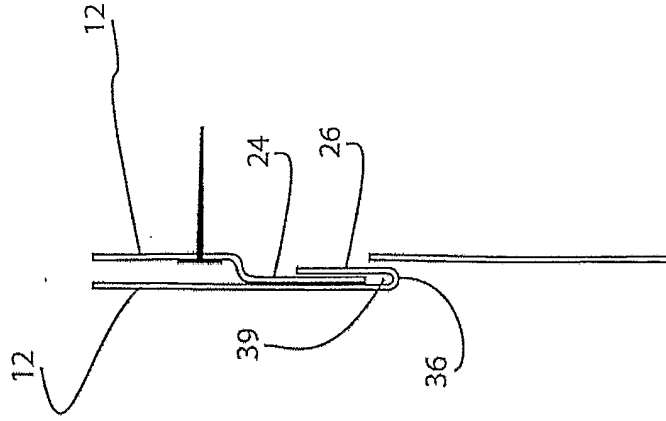

Fig 6C



Thomas

# Fig 7A

## Sec.A

Exterior Water

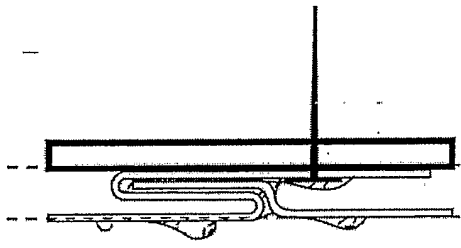

## Sec.B

Vapor Condensation

- - - - -  
 Interior Cladding to  
 Substrate Zone  
 - - - - -

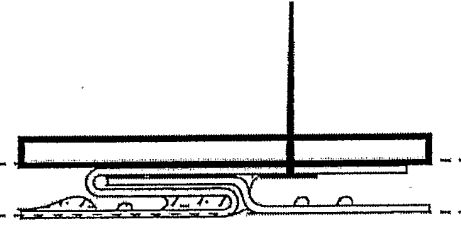

# Fig 7B

## Sec.A

Exterior Water

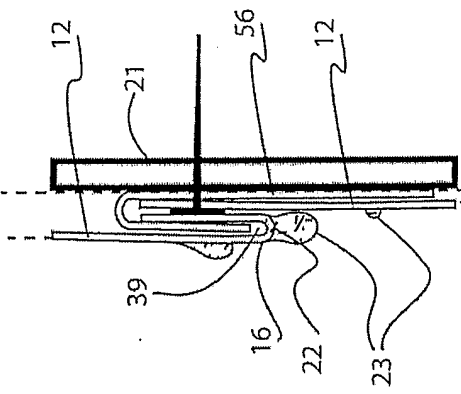

## Sec.B

Vapor Condensation

FIG 7D

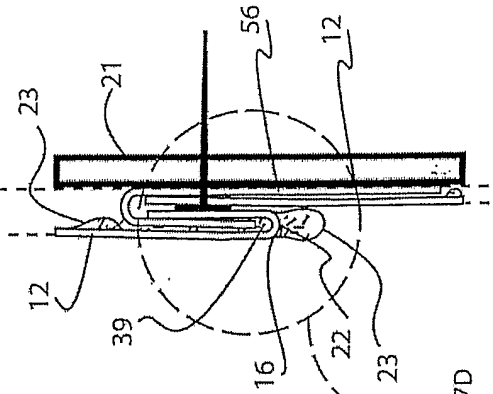

# Fig 7C

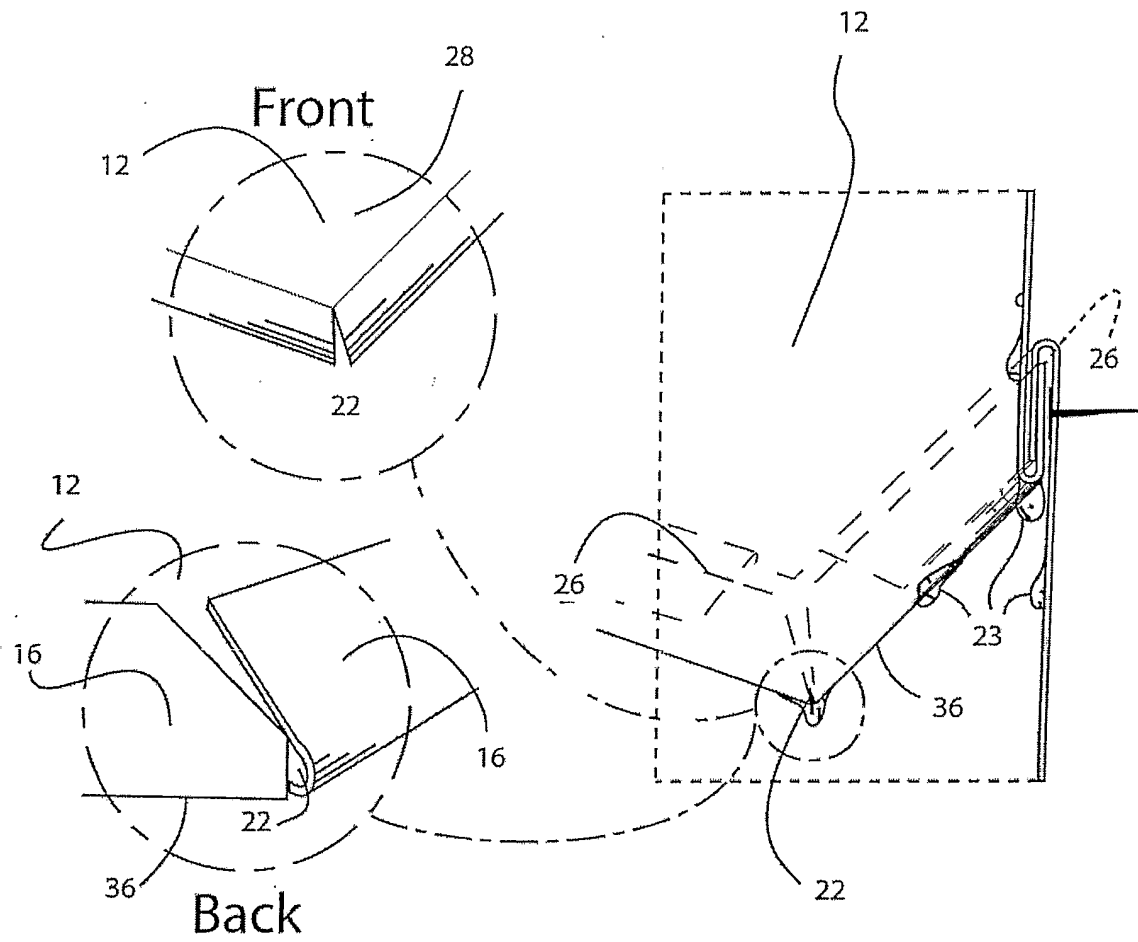

# Fig 8

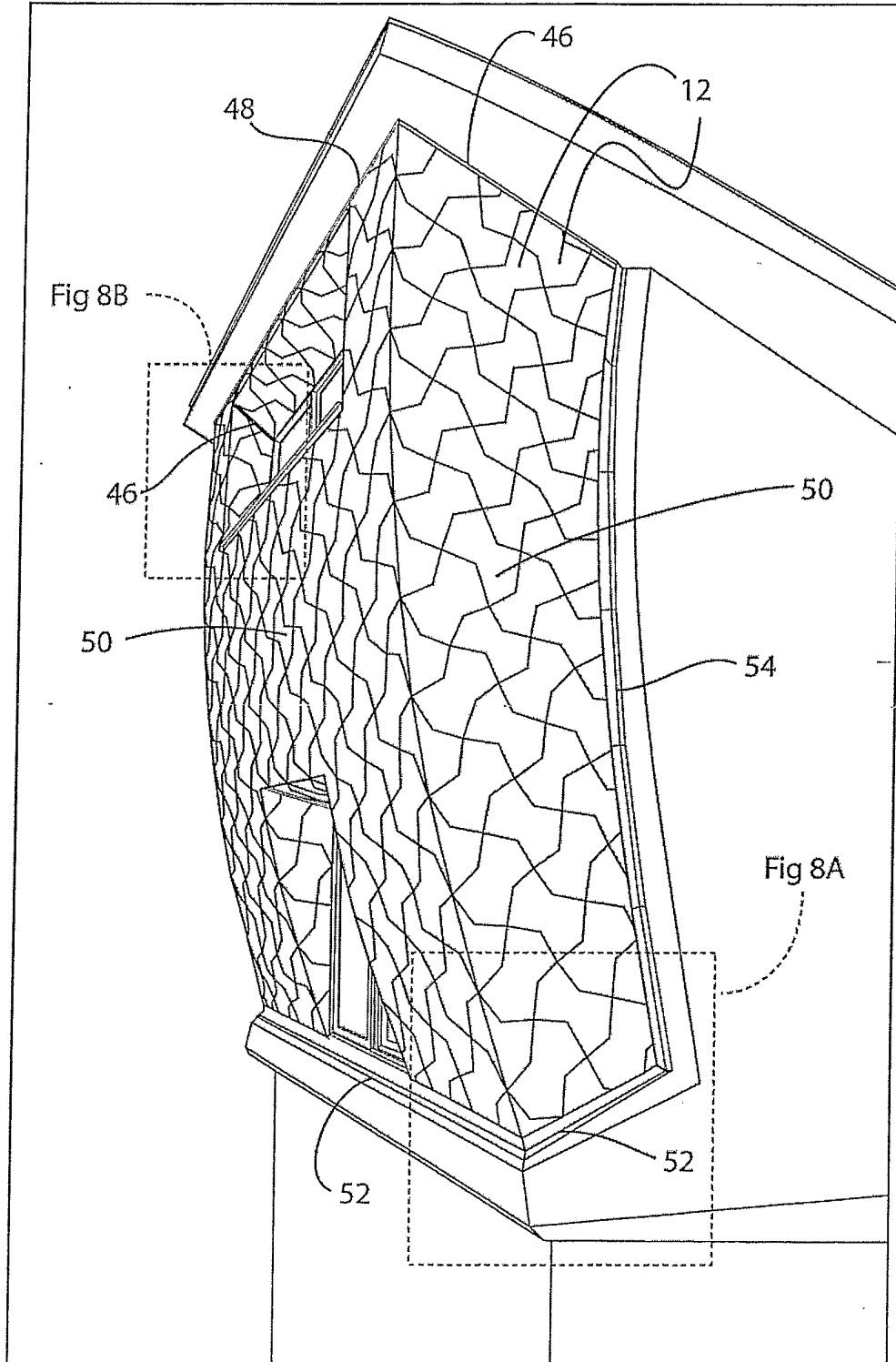

# Fig 8A

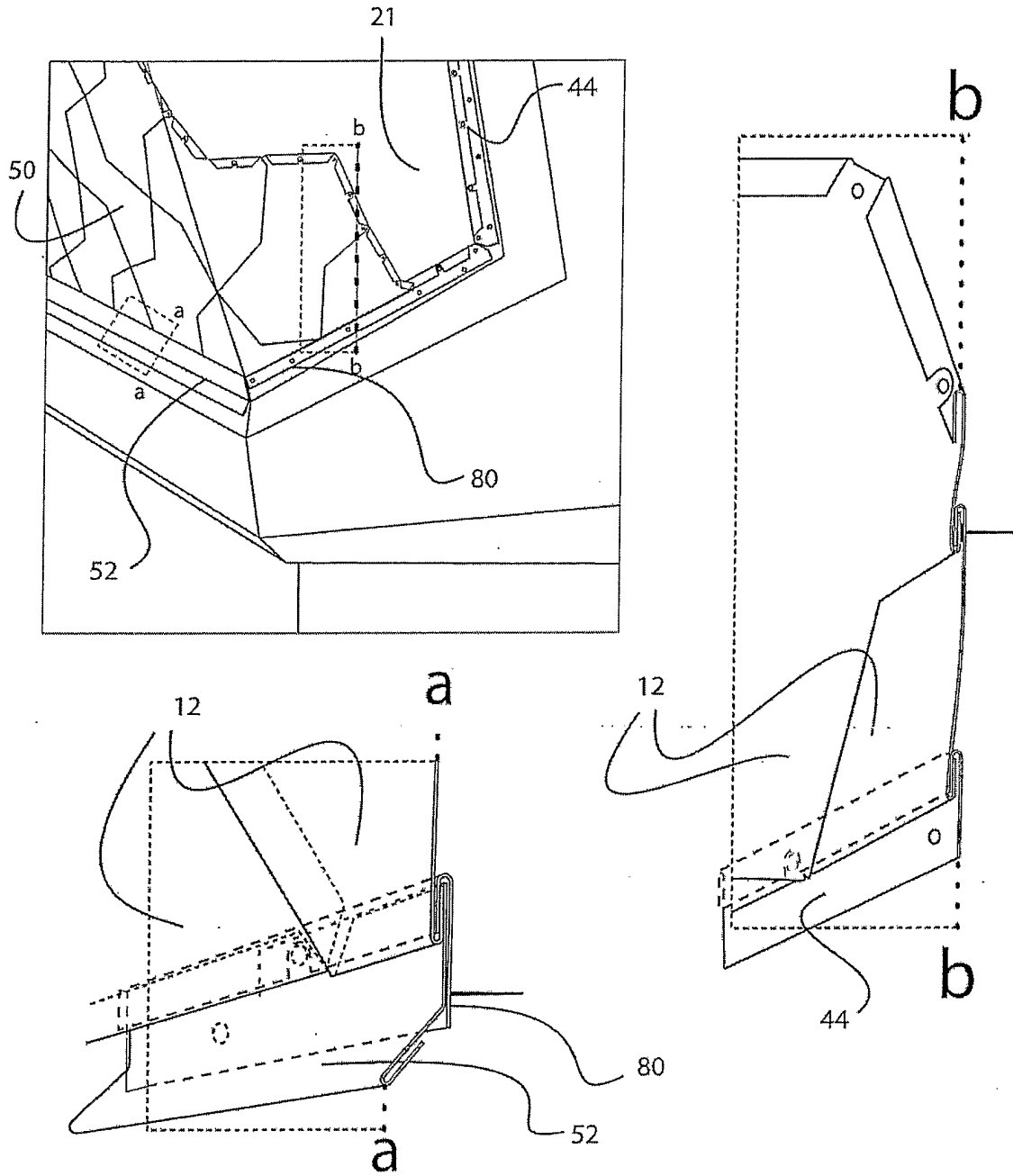

# Fig 8B

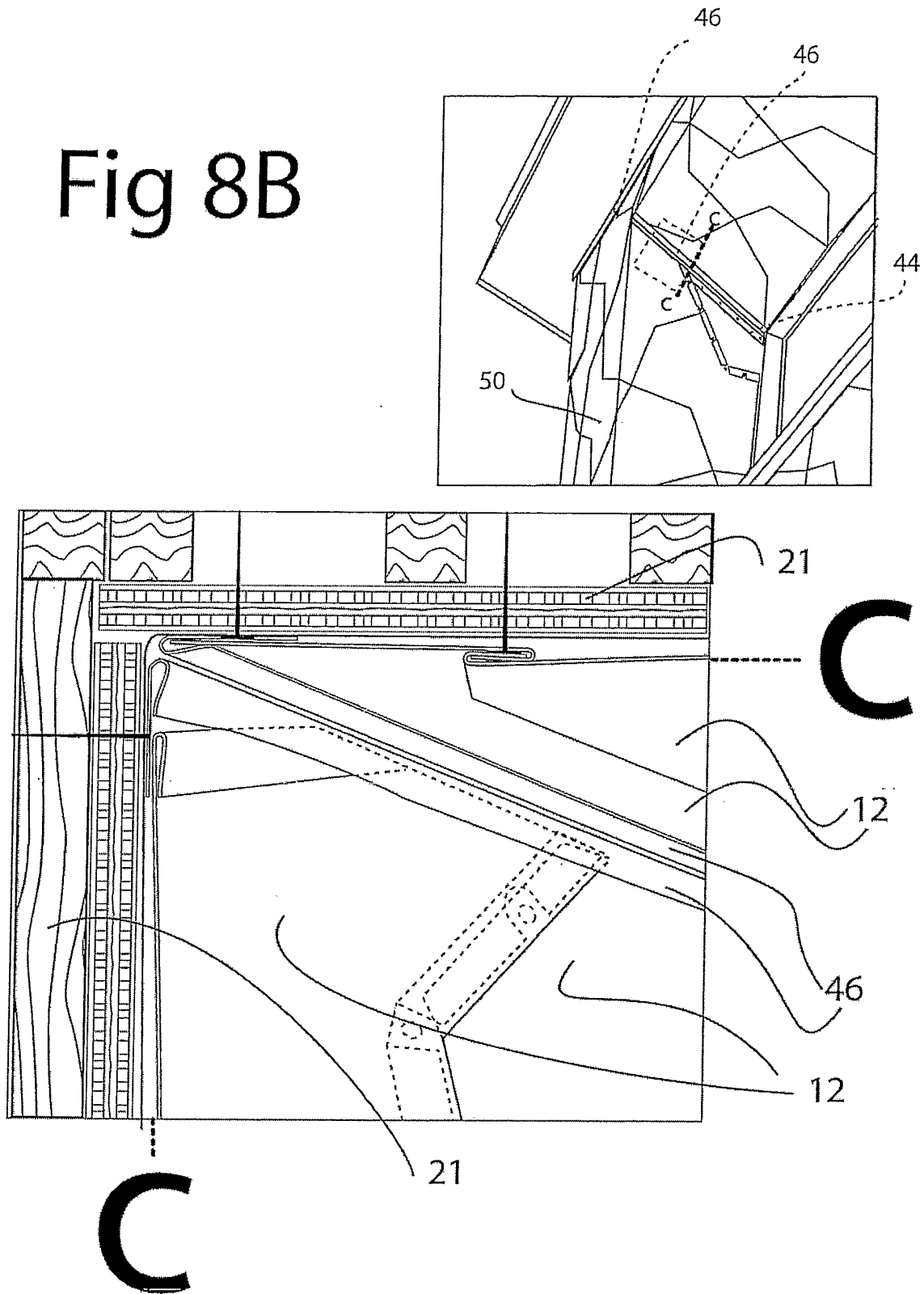

# Fig 9

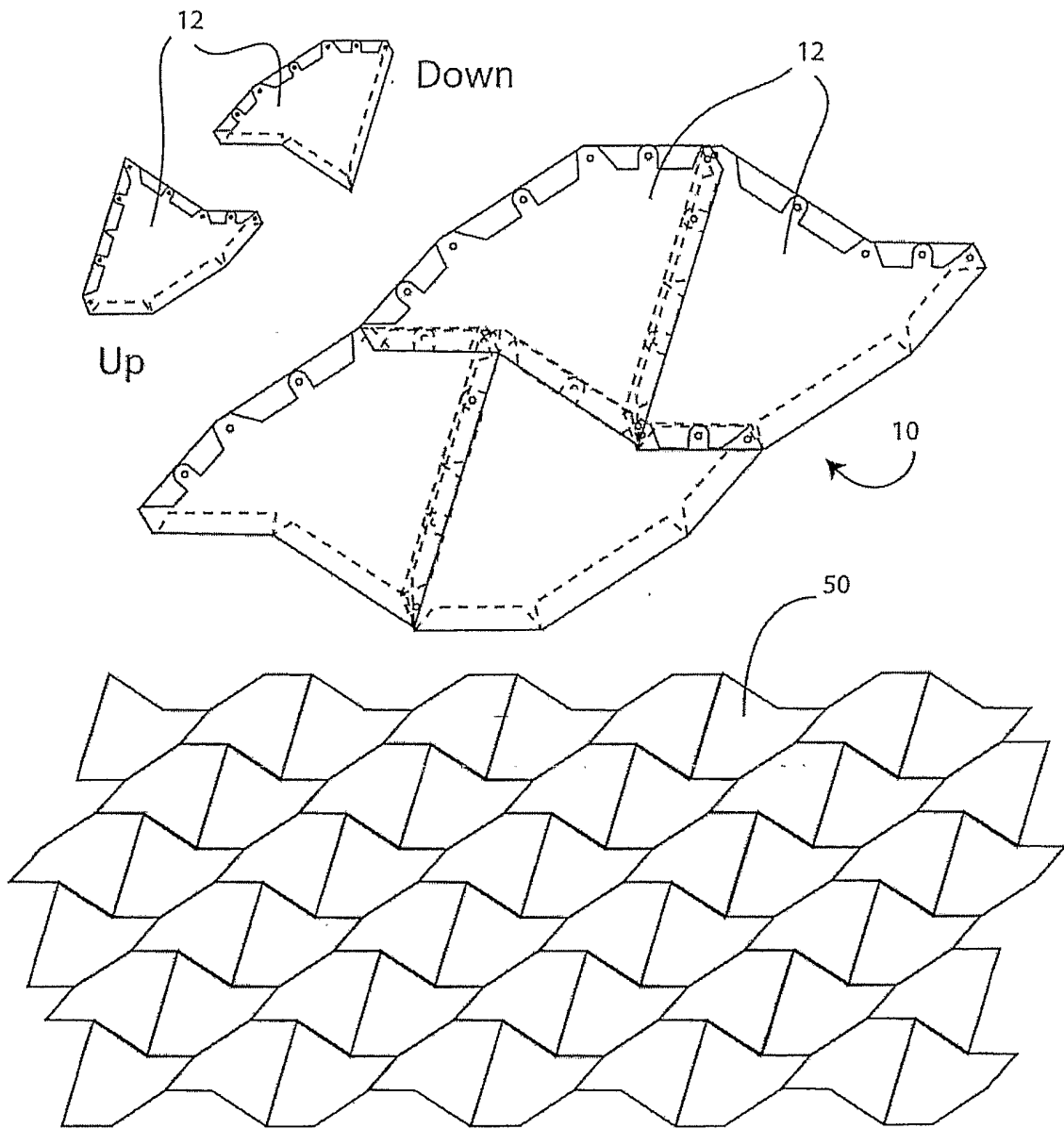

# Fig 10

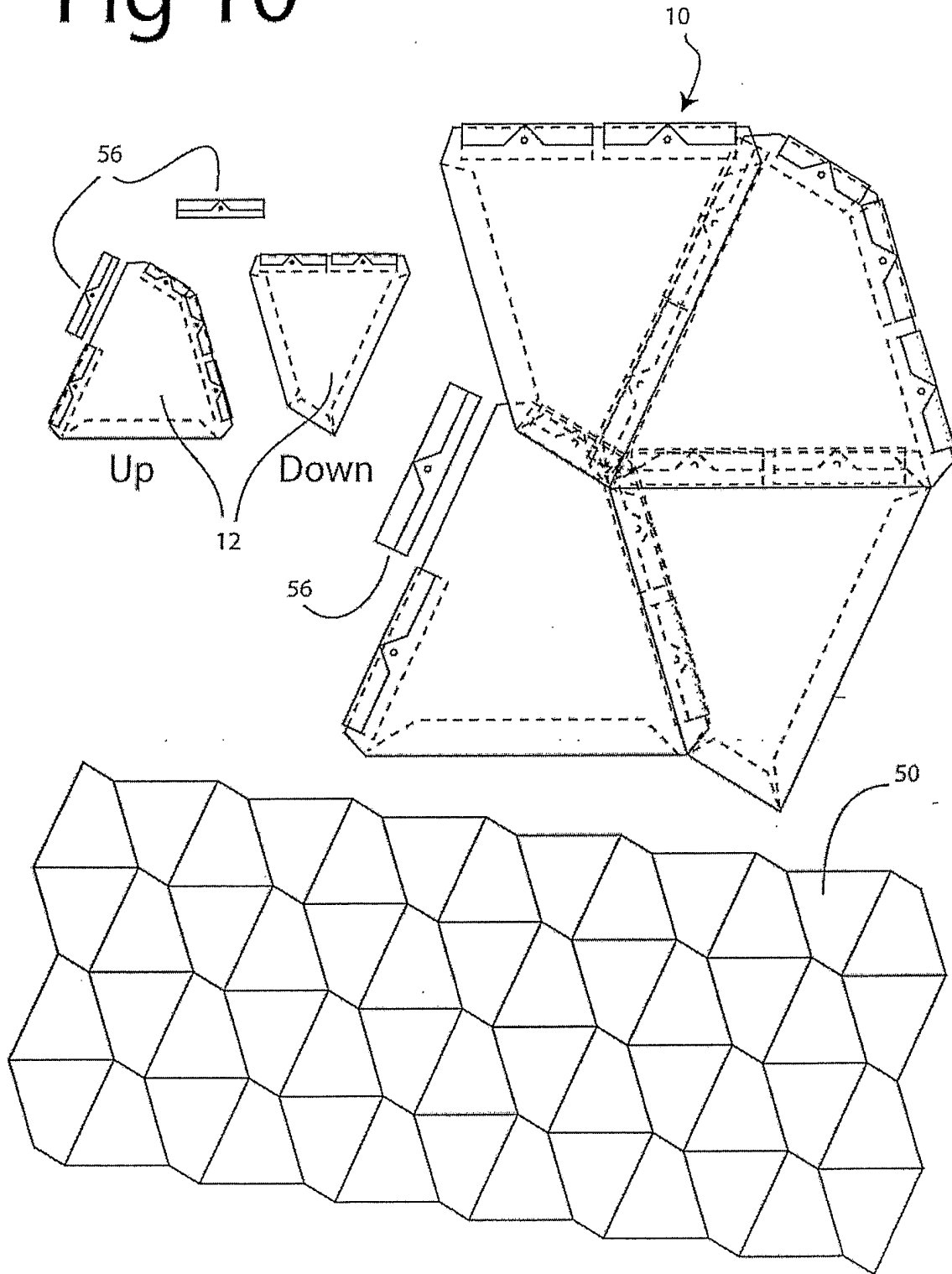

# Fig 11

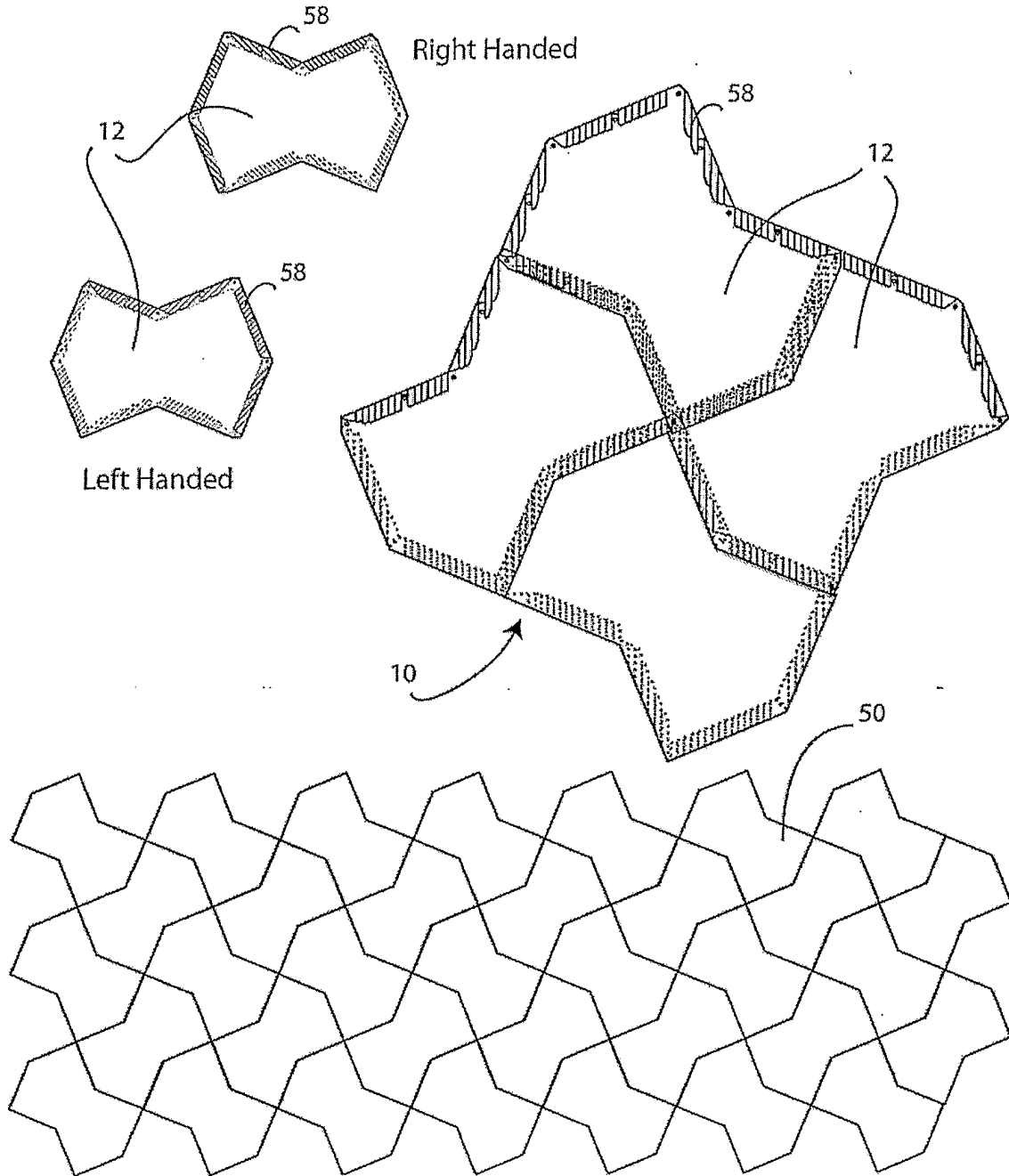

# Fig 12

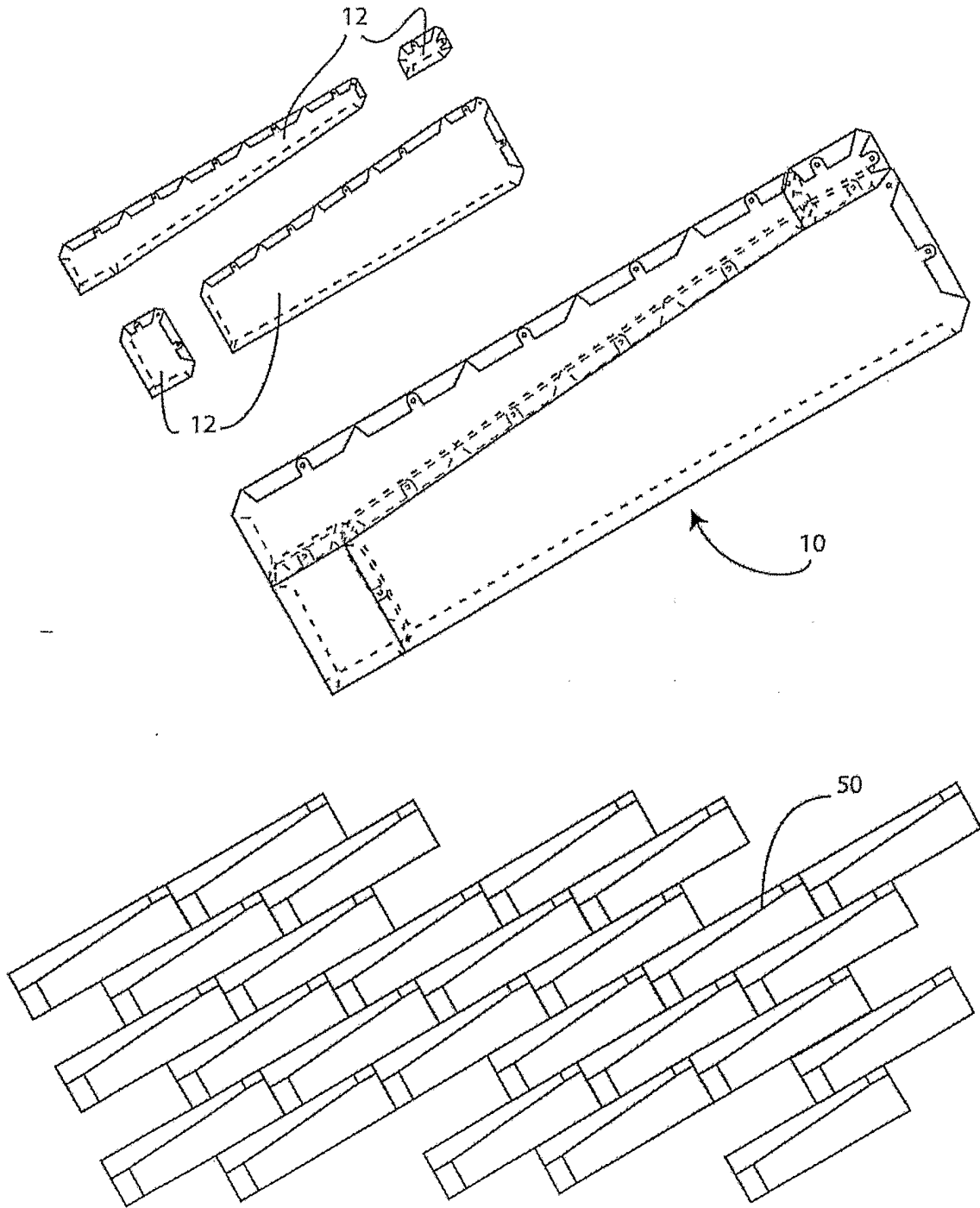

# Fig 13

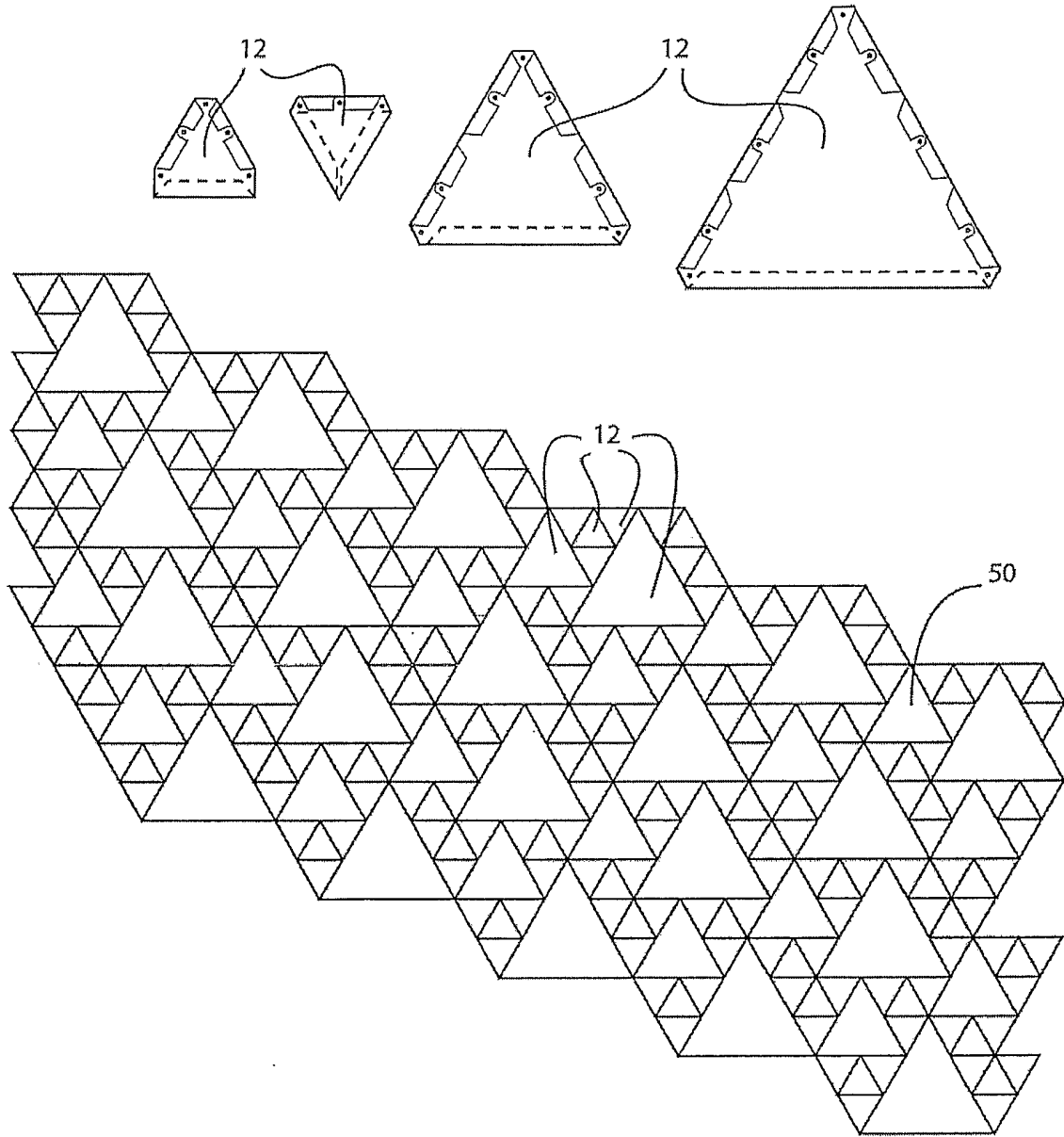

# Fig 14

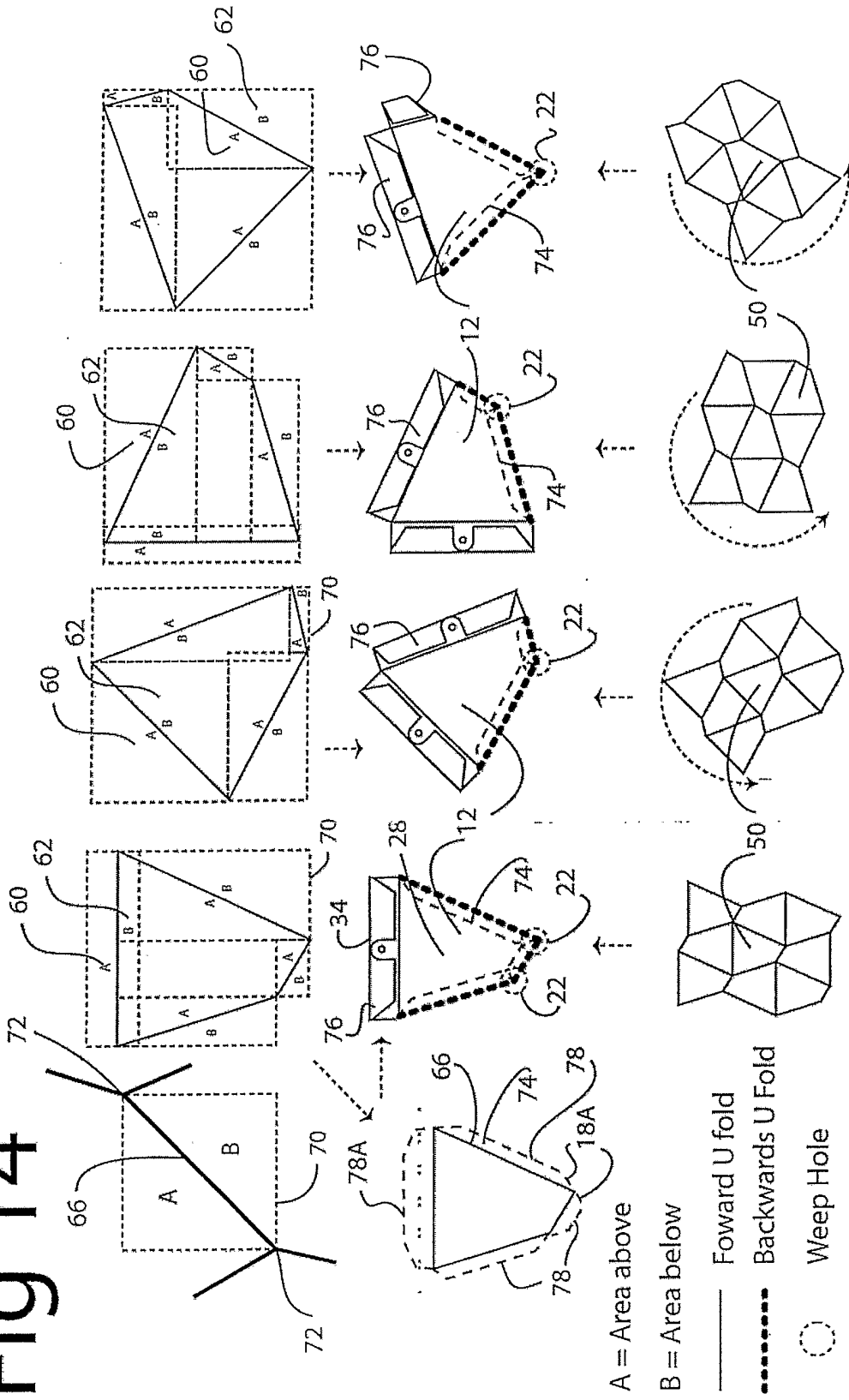

Fig 15A

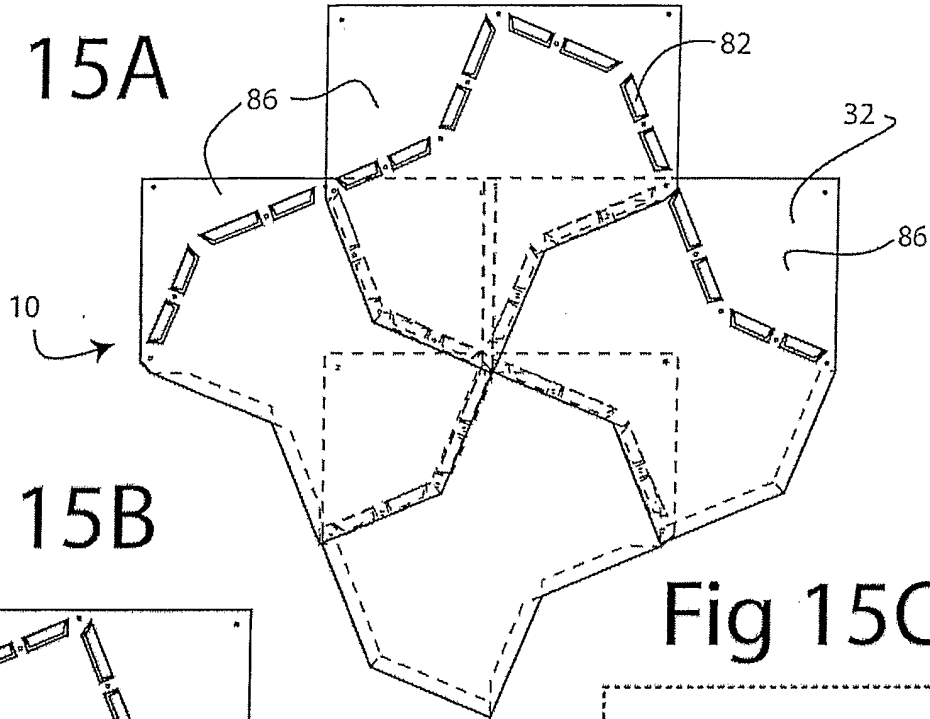

Fig 15B

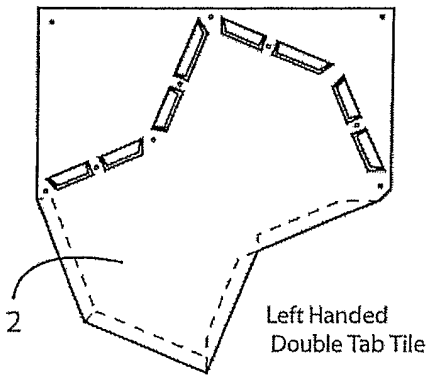
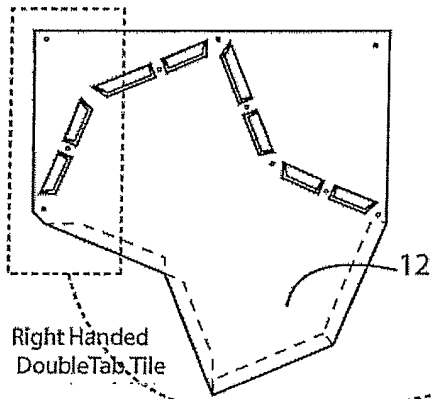

Fig 15C

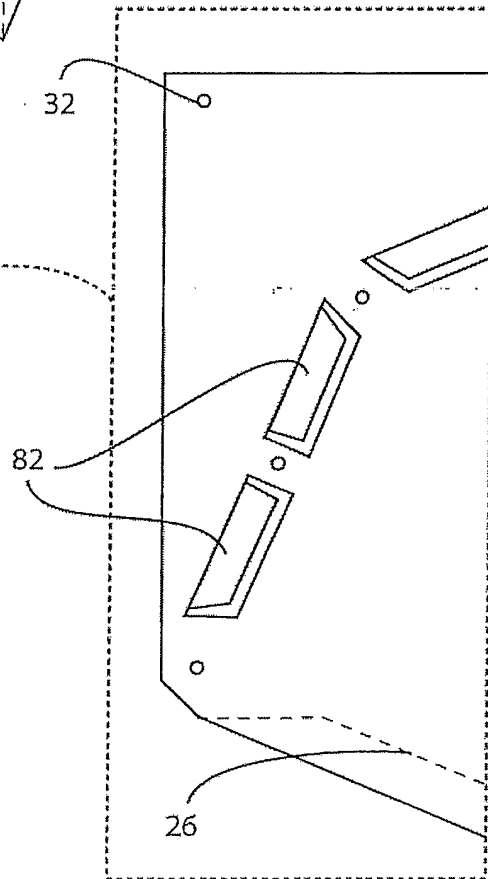

Fig 16A

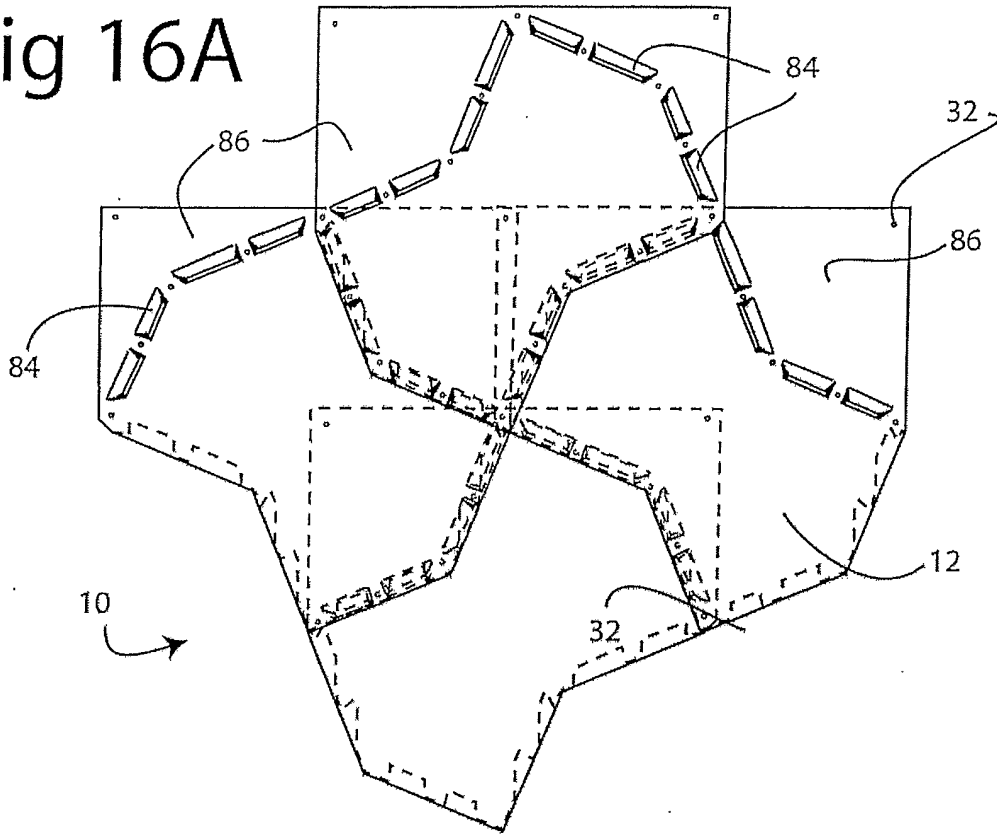
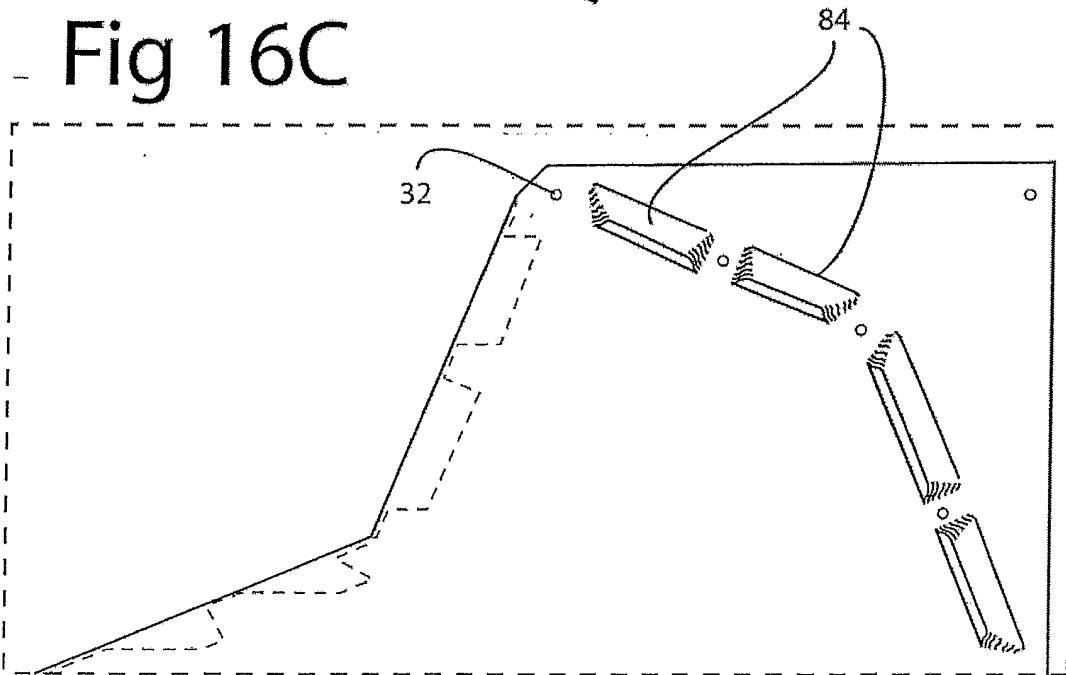

Fig 16C



# Fig 16B

