



- (51) International Patent Classification:  
*B60P 1/16* (2006.01)
- (21) International Application Number:  
PCT/IB2014/063424
- (22) International Filing Date:  
25 July 2014 (25.07.2014)
- (25) Filing Language: English
- (26) Publication Language: English
- (30) Priority Data:  
2013/05649 25 July 2013 (25.07.2013) ZA
- (71) Applicant: RULA BULK MATERIALS HOLDING (PTY) LTD [ZA/ZA]; 42 Kielboot Avenue, Laserpark, Honeydew Ext. 5, 2170 Johannesburg (ZA).
- (72) Inventors: ODENDAAL, Roelf Fredrick; 2 Linaria Street, Weltevreden Park, 1709 Johannesburg (ZA). JANSSEN VAN RENSBURG, Theodorus; 33 Heathfield, Davidson Street, Fairland, 2170 Johannesburg (ZA).
- (74) Agents: SPOOR & FISHER et al.; P O Box 454, 0001 Pretoria (ZA).
- (81) Designated States (unless otherwise indicated, for every kind of national protection available): AE, AG, AL, AM, AO, AT, AU, AZ, BA, BB, BG, BH, BN, BR, BW, BY,

BZ, CA, CH, CL, CN, CO, CR, CU, CZ, DE, DK, DM, DO, DZ, EC, EE, EG, ES, FI, GB, GD, GE, GH, GM, GT, HN, HR, HU, ID, IL, IN, IR, IS, JP, KE, KG, KN, KP, KR, KZ, LA, LC, LK, LR, LS, LT, LU, LY, MA, MD, ME, MG, MK, MN, MW, MX, MY, MZ, NA, NG, NI, NO, NZ, OM, PA, PE, PG, PH, PL, PT, QA, RO, RS, RU, RW, SA, SC, SD, SE, SG, SK, SL, SM, ST, SV, SY, TH, TJ, TM, TN, TR, TT, TZ, UA, UG, US, UZ, VC, VN, ZA, ZM, ZW.

- (84) Designated States (unless otherwise indicated, for every kind of regional protection available): ARIPO (BW, GH, GM, KE, LR, LS, MW, MZ, NA, RW, SD, SL, SZ, TZ, UG, ZM, ZW), Eurasian (AM, AZ, BY, KG, KZ, RU, TJ, TM), European (AL, AT, BE, BG, CH, CY, CZ, DE, DK, EE, ES, FI, FR, GB, GR, HR, HU, IE, IS, IT, LT, LU, LV, MC, MK, MT, NL, NO, PL, PT, RO, RS, SE, SI, SK, SM, TR), OAPI (BF, BJ, CF, CG, CI, CM, GA, GN, GQ, GW, KM, ML, MR, NE, SN, TD, TG).

**Declarations under Rule 4.17:**

- as to applicant's entitlement to apply for and be granted a patent (Rule 4.17(ii))

**Published:**

- without international search report and to be republished upon receipt of that report (Rule 48.2(g))

(54) Title: CONTAINER DISCHARGE SYSTEM, CONTAINER AND METHOD OF DISCHARGING SUCH CONTAINER

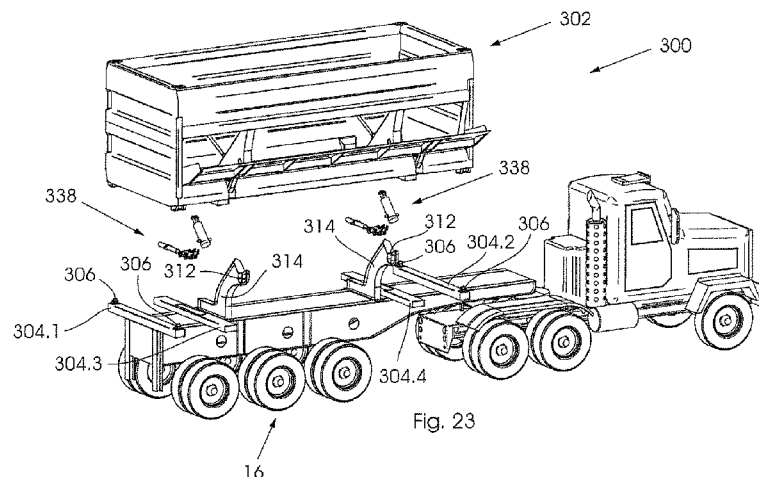

(57) Abstract: This invention concerns a container handling system which allows containers (12, 302) to be freely moved from road trailers (16) to rail wagons (102), and vice versa. The system includes a sub-system (10, 300) for handling containers (10, 302) for transporting the containers (12, 302) by road and a sub-system (100, 400) for transporting the containers (12, 302) by rail. The system includes a side discharge container (12, 302) which has at least one door (18) through which the bulk material can be discharged. The container (12, 302) has a door mechanism (40, 322) which is operable between a first, locked position wherein the container door (18) is locked in its closed position and a second, unlocked position wherein the container door (18) is open to discharge the bulk material. The container (302) has pivot connectors (310) located on support structures (318) located inside the container (302) that engage complementally shaped pivot connectors (312) carried on a carriage, typically a trailer (16) or train wagon (102). The system further includes a container tilting device (406) and a door actuating mechanism (338) carried by the carriage (16) for engaging the door mechanism (40, 322) and tilting the container (12, 302) in order to discharge the bulk material by either using the container tilting device (406) or the door actuating mechanism (338).



**CONTAINER DISCHARGE SYSTEM, CONTAINER AND METHOD OF  
DISCHARGING SUCH CONTAINER**

**BACKGROUND TO THE INVENTION**

This invention relates to a container discharge system, a container and a method of discharging such container. In particular, but not exclusively, the invention relates to container handling system for handling free-flowing bulk material.

Bulk material, such as grain, ores, coal, sand, gravel and stone, is generally transported in loose bulk form in open or closed containers. The containers are transported by road and/or railway to ports and airports where they are shipped onwards to their final destinations for processing. A person familiar with the handling of bulk material will know that the loading and discharging of the containers in which the bulk material is shipped is one particular area of the handling process which is time consuming and, accordingly, generally expensive. The faster the bulk material can be discharged from

-2-

the containers the quicker it can be processed and the more efficient the entire process becomes.

A number of different solutions have been proposed for the fast discharging of containers. In one known solution a container tilting machine is used to flip the entire container upside down to discharge the bulk material therein. A problem with this known solution is that in order to tilt the container the container locks locking it onto the train wagon or truck bed must be unlocked before the container can be flipped upside down. After discharging the container must again be locked onto the train wagon or truck bed before it can be transported away from the discharge location. The locking and unlocking of the container locks are time consuming and causes considerable delays in the discharging process. To address this issue it has been suggested to tilt the container together with the train wagon or truck bed onto which it is locked. Although this solution addressed the time delays it requires very large container handling machines to be able to handle the combined weight of the container and truck bed. Safety is also a concern when tilting the combined weight of the container and carriage.

Another known solution is to make use of a bottom discharge container which does not need to be tilted in order to discharge its contents. In use, the bottom discharge containers are lifted using a crane and moved over the discharge location where the bulk material is dropped through the container's bottom discharge doors. Although the use of the bottom discharge containers does not require specialised machinery to discharge the bulk material, it does not address the problem of having to lock and unlock the container locks as described above.

Yet another known solution makes use of a side discharge container to discharge the bulk material. In this solution the container together with the train wagon on which it is being transported are tilted sideways to discharge the bulk material through its side doors. The problem with this solution is that it again requires a specifically designed station where the container is

-3-

tilted as it driven through the station. The discharge station is again large and bulky to be able to handle the combined weight of the wagon and container. However, the main disadvantage of this solution is that the discharge station is specifically designed for a particular wagon and container combination and, accordingly, it is not compatible with other container and carriage combinations. As a result, this solution cannot be used where the containers are being transported by road, such as on the back of a truck bed.

It is an object of this invention to alleviate at least some of the problems experienced with existing container discharge systems.

It is a further object of this invention to provide a container handling system and method that will be useful alternatives to existing systems and methods.

### **SUMMARY OF THE INVENTION**

In accordance with a first aspect of the invention there is provided a side discharge container for transporting bulk material, the container including:

at least one door through which the bulk material can be discharged;  
and

a door mechanism which is operable between a first, locked position wherein the container door is locked in its closed position and a second, unlocked position wherein the container door is open to discharge the bulk material, wherein the door mechanism includes a series of links which are movably connected to one another, wherein at least one of the links carries an engagement formation for engaging a door actuating mechanism, and wherein at least one of the links carries another engagement formation for engaging a container tilting device, such that the door mechanism is operable by using either the door actuating mechanism or the container tilting device.

-4-

The series of links may include an actuating link which is connected pivotally to the container body, and a connecting link which connects the actuating link to a drive link. The engagement formation for engaging the door actuating mechanism may be carried by the drive link such that movement of the drive link causes the actuating link to pivot relative to the container body in order to open and close the container door. The engagement formation for engaging the container tilting device may also be carried by the drive link such that the drive link is movable through either engagement with the door actuating mechanism or container tilting device in order to cause the actuating link to pivot relative to the container body in order to open and close the container door. The series of links may further include a second actuating link pivotally connected to the container, wherein the engagement formation for engaging the container tilting device is located on the second actuating link.

The connecting link may comprise a pre-tensioning device for adjusting the force acting to keep the door in its closed position. Preferably, the door mechanism also includes locking means which automatically locks the door in its closed position when the door mechanism is moved into its locked position.

In the preferred embodiment the connecting link is carried on a slide which moves on a support surface defining a notch, and wherein the slide is moved past the notch when moving the door mechanism into its closed position, thereby automatically locking the connecting link in an over-centre position in order to lock the container door in its closed position.

The container may further include second locking means which automatically locks the door in its closed position when the door mechanism is moved into its locked position. Preferably, the second locking means is in the form of complementally shaped locking formations located on one of the links of the door mechanism and the container, the locking formations being arranged so as to engage one another when the door mechanism is in its closed position, such that, in use, the link carrying the

-5-

locking formation must first be lifted to disengage the locking formations from one another to allow the door mechanism to be moved into its open position.

In one embodiment of the invention the container has a sloped floor which at least in part slopes generally upward towards the sidewall in which the container door is located. In this embodiment the door mechanism may be at least partially located in a cavity provided between the sloped container floor and the bottom of the container. The container door is then preferably hinged to a raised portion of the sloped floor so as to raise the hinge point about which the door hinges when moving between its open and closed positions.

The container preferably includes pivot connectors for engaging complementally shaped pivot connectors provided on a carriage on which the container is, in use, transported, wherein the pivot connectors on the container are located on support structures located inside the container, and wherein the container includes cavities in which the pivot connectors on the carriage is in used received when the container is located on the carriage. The cavities in which the pivot connectors of the carriage are received may open to the bottom of the container so that the pivot connectors of the carriage are received through the floor of the container when the container is lowered onto the carriage.

In accordance with a second aspect of the invention there is provided a method of discharging a side discharge container carried, in use, on a carriage, the method including the steps of:

- engaging a door mechanism which is operable between a first, locked position wherein a container door is locked in its closed position and a second, unlocked position wherein the container door is open to discharge the bulk material;

- disengaging a locking device to allow movement of the door mechanism from its locked position into its unlocked position;

-6-

moving a linkage of the door mechanism to move the door mechanism from its locked position into its unlocked position, thereby opening the door of the container to start discharging the bulk material from the container;

pivoting the container about a pivot axis running substantially parallel to the longitudinal length of the container from a transport position to a discharge position;

pivoting the container back into its transport position;

closing the container door by moving the linkage of the door mechanism to move the door mechanism from its unlocked position into its locked position; and

automatically locking the door in its closed position by moving the door mechanism back into its locked position.

The step of engaging the door mechanism may include engaging an engagement formation carried by a door actuation mechanism with a complementally shaped engagement formation carried on the linkage of the door mechanism.

In one embodiment of the invention the step of moving the door mechanism from its locked position into its unlocked position includes moving engagement means carrying the engagement formation of the door actuation mechanism in a first direction of movement through actuation of a first actuator.

The step of pivoting the container from its transport position to its discharge position preferably includes first moving the engagement means carrying the engagement formation of the door actuation mechanism in a second direction of movement, which is substantially opposite the first direction of movement, through actuation of a second actuator in order to allow the engagement formation of the door actuating mechanism to be released from the engagement means. The step of pivoting the container from its transport position to its discharge position may further include actuating the first actuator.

-7-

The method may further include operating both actuators simultaneously for controlled movement of the container door when opening the door while the container is carrying bulk material, thereby preventing the container door from collapsing from its closed position into its open position under the weight of the bulk material.

Preferably, the locking device is automatically unlocked when the container is loaded onto the carriage.

The container door is also preferably locked automatically by over-centring a connecting link of the door mechanism.

The step of engaging the door mechanism may include engaging an engagement formation carried by a container tilting device with a complementally shaped engagement formation carried on the linkage of the door mechanism.

The step of disengaging the locking device may include lifting the linkage of the door mechanism to remove a locking formation from a recess formed on the linkage.

In accordance with a third aspect of the invention there is provided a container tilting device for discharging a container carried on a carriage, the device including:

    a coupling mechanism having a bar carrying a coupler for coupling to the container and a movable slide which, in use, carries the bar along a first axis of movement, the bar being movable with respect to the slide along a second axis of movement;

    an actuating mechanism carrying engaging means for engaging complementally shaped engaging means of the bar so that when the complementally engaging means are engaged the bar may be moved back and forth along the second axis of movement through actuation of the actuating mechanism to move the coupler carried by the bar to and from the container; and

-8-

a lifting system to move the slide carrying the bar along the first axis of movement;

such that, in use, the first axis of movement is substantially vertical so that the coupler is lifted when the slide is moved upwardly by the lifting system in order to tilt the container when the coupler is connected thereto, thereby causing the bulk material to be discharged from the container.

In one embodiment the engaging means of the actuating mechanism is in the form of an open recess defined in a movable catch such that the engaging means carried by the bar is automatically released from the recess through the upward movement of the slide so as to allow the bar to move freely along the second axis of movement while being lifted by the slide, thereby allowing the coupler to travel along an arcuate path during tilting of the container from its transport position into its discharge position.

The actuating mechanism preferably includes a first actuator for moving the catch along the second axis of movement. Preferably, the first actuator is in the form of a double acting hydraulic piston and cylinder assembly.

The lifting system may include a trolley which is movably mounted inside a frame structure in a manner allowing the trolley to be movable along the first axis of movement, the slide being movably mounted inside the trolley, and the lifting mechanism may include at least one actuator for moving the trolley along the first axis of movement.

The lifting system preferably includes a series of pulleys carried by the trolley and a flexible drive means running from the slide, over the pulleys and back to the slide such that so as to cause the vertical slide to move when the trolley is moved through actuation of the actuator driving the trolley. The flexible drive means is preferably a chain and the pulleys are preferably sprockets.

The lifting system may further include two separate chains, each having their corresponding series of sprockets so as to balance the forces acting on the trolley and slide during actuation of the actuator driving the trolley.

In the preferred embodiment the actuator driving the trolley is a double acting hydraulic piston and cylinder assembly.

In one embodiment the container tilting device includes two coupling mechanisms for coupling to the container at two positions. Each coupling mechanism preferably has its own actuating mechanism and lifting system. Preferably, the movement of the coupling mechanisms are synchronised.

There is provided for the container tilting device to include a gripping device for gripping onto the carriage during discharging of the container, thereby acting as a safety mechanism to prevent any accidental flipping of carriage. Preferably, a gripping portion which, in use, grips onto the carriage is movable along both the first and second axes of movement, thereby allowing the gripping portion to be movable toward and away from the carriage on which the container is being carried and to compensate for a height differential between different carriages.

The container tilting device may include a wheeled base thereby allowing the device to be movable between different containers without having to move the carriage. In one embodiment the container tilting device also includes a propulsion system and braking system.

Sensors for automatically aligning the container tilting device with the container carried on the carriage may be located on the container tilting device.

In accordance with a fourth aspect of the invention there is provided a method of discharging a container being carried on a carriage using a container tilting device according, the method including the following steps:

- moving the container tiling device alongside the container;
- moving a coupler for coupling to the container in a direction towards the container;
- lifting the coupler to engage it with a corresponding engagement formation located on a door mechanism of the container;

-10-

moving the coupler in a direction away from the container in order to actuate the door mechanism to open a side discharge door in the container;

lifting the coupler to tilt the container from its transport position into its discharge position;

lowering the coupler after discharge of the bulk material so that the container is moved back into its transport position;

moving the coupler in a direction towards the container in order to close the container door; and

lowering the coupler further to disengage the door mechanism of the container.

The step of moving the container tilting device alongside the container may include automatically aligning the coupler with the door mechanism on the container by using sensors to detect the position of the container. Alternatively, the step of moving the container tilting device alongside the container may include automatically aligning the coupler with the door mechanism on the container by extending a latching arm mounted on the container tilting device into the travel path of the carriage.

The method may further include disengaging locking means acting between the door mechanism and container before moving the coupler in a direction away from the container to actuate the door mechanism. This step may further include lifting the coupler after it is engaged with the corresponding engagement formation located on the door mechanism, thereby to remove a locking formation of the locking means from a recess in which the locking formation is received when the locking means is engaged. The method may yet further include automatically engaging the locking means when closing the container door and disengaging the door mechanism.

In the method the step of lifting the coupler to tilt the container from its transport position into its discharge position may include allowing the coupler to move freely along an arcuate path.

-11-

The method may also include the step of providing a pulley system to achieve a gain in travel distance of the coupler relative to the travel distance of an actuator used in lifting the coupler of at least two. The method preferably includes the use of two separate flexible drive means each having its corresponding series of pulleys so as to balance the forces acting on coupler during the tilting of the container.

In the preferred embodiment double acting hydraulic piston and cylinder assemblies are used to move the coupler.

Preferably, two couplers for coupling to the container at two positions are provided. The movement of the two couplers are preferably synchronised.

The method may further include holding onto the carriage during discharging of the container, thereby providing a safety mechanism to prevent any accidental flipping of the carriage.

The method preferably includes mounting the container tilting device on a wheeled base thereby allowing the device to be movable between different containers without having to move the carriage. The container tilting device may be moved between different containers or carriages by using a propulsion system and braking system of the container tilting device.

The discharge process may be carried out while the carriage and the container mounted thereon are in motion.

In accordance with a fifth aspect of the invention there is provided a container handling system for discharging bulk material, the system including:

- a side discharge container including:

- at least one door through which the bulk material can be discharged;

- a door mechanism which is operable between a first, locked position wherein the container door is locked in its closed position and

-12-

a second, unlocked position wherein the container door is open to discharge the bulk material; and

pivot connectors located on support structures located inside the container;

a carriage on which the container is in use mounted, the carriage carrying pivot connectors for engagement with the complementally shaped pivot connectors on the container so that the container may be pivoted, about a pivot axis running substantially along the longitudinal length of the carriage; and

a container tilting device for engaging the door mechanism and tilting the container while the container is mounted on the carriage;

such that the container may be tilted in order to discharge the bulk material by either using an actuating mechanism carried by the carriage or using the container tilting device.

The container is preferably a container in accordance with the first aspect of the invention while the container tilting device is preferably a device in accordance with the third aspect of the invention.

There is provided for the carriage to be either a truck drawn trailer or a train wagon.

#### **BRIEF DESCRIPTION OF THE DRAWINGS**

The invention will now be described in more detail, by way of example only, with reference to the accompanying drawings in which:

**Figure 1** shows a sub-system of a container handling system according to the invention including a container, cradle and carriage shown in an exploded perspective view;

- Figure 2** shows a perspective view of the container of the sub-system of Figure 1;
- Figure 3** shows a side view of a container door of the container shown in Figure 2;
- Figure 4** shows a cross-sectional view of the container of Figure 2 wherein a door mechanism can be seen in two different positions;
- Figure 5** shows a pre-tensioning device of the door mechanism of Figure 4;
- Figure 6** shows a perspective view of the door mechanism of Figure 4 including another embodiment of a pre-tensioning device;
- Figure 7** shows a perspective view of the cradle of the sub-system of Figure 1;
- Figure 8** shows a partial cross-sectional view of the cradle of Figure 7 wherein the container can be seen both mounted on and dismounted from the cradle;
- Figure 9** shows a partial cross-sectional view of the cradle of Figure 7 illustrating the interaction with the door mechanism;
- Figure 10** shows an end view of the cradle of Figure 7 tilted halfway between its transport and discharge positions;
- Figure 11** illustrates the different stages of the method of discharging a container using the sub-system of Figure 1;

- Figure 12** shows cross-sectional end views of the container during different stages of the method of discharging a container illustrated in Figure 10;
- Figure 13** shows a perspective view of a sub-system of the container handling system of the invention including a container and train wagon shown in exploded perspective view;
- Figure 14** shows an end view of a container tilting device of the sub-system of Figure 13 for use in discharging a container carried on the train wagon;
- Figure 15** shows a top of the device of Figure 14 located next to a container carried on the wagon;
- Figure 16** shows a perspective view of a coupler hook of a coupling mechanism of the device of Figure 14;
- Figure 17** shows a partially exploded perspective view of a trolley of the device of Figure 14;
- Figure 18** illustrates the movement of a swing bar of the coupling mechanism of the device of Figure 14;
- Figure 19** illustrates the coupling action between the container and coupling mechanism of Figure 14;
- Figure 20** illustrates the step of opening a door of the container by using the coupling mechanism of Figure 14;
- Figure 21** shows a detailed view of a locking arrangement of the drive link of the door mechanism of the container of the invention;

- Figure 22** illustrates different steps of a discharge process using the container tilting device of the system of Figure 12;
- Figure 23** shows a sub-system of the container handling system according to a second embodiment of the invention including a container and carriage shown in an exploded perspective view;
- Figure 24** shows a rear perspective view of the sub-system of Figure 23;
- Figure 25** shows a perspective view of the container of the sub-system of Figure 23;
- Figure 26** shows a cross-sectional view of the container of Figure 25 wherein a door mechanism can be seen in two different positions;
- Figure 27** shows a partial cross-sectional view of the container and carriage in which the door mechanism of Figure 26 and an actuating mechanism of the carriage can be seen;
- Figure 28** illustrates different stages of the door mechanism and actuating mechanism of Figure 27 during discharge;
- Figure 29** illustrates the different stages of the method of discharging a container using the sub-system of Figure 23;
- Figure 30** shows cross-sectional end views of the container during different stages of the method of discharging a container illustrated in Figure 29;
- Figure 31** shows a perspective view of a sub-system of the container handling system in accordance with a second embodiment

of the invention including a container and train wagon shown in exploded perspective view;

- Figure 32** shows a perspective view of a container tilting device of the sub-system of Figure 31;
- Figure 33** shows a perspective view of a coupling mechanism of the device of Figure 32;
- Figure 34** shows a side view of the coupling mechanism of Figure 33;
- Figure 35** shows an end view of the coupling mechanism of Figure 34 in which a lifting system can be seen;
- Figure 36** shows different positions of a gripping device of the container tilting device of Figure 32;
- Figure 37** shows a top of the container tilting device of Figure 12 located next to the train wagon of the sub-system of Figure 31;
- Figure 38** illustrates different stages of the discharge process using the container tilting device of Figure 32;
- Figure 39** illustrates different stages of the process of unlocking rear locking means by using the door actuating mechanism of the sub-system of Figure 23; and
- Figure 40** illustrates different stages of the process of unlocking rear locking means by using the container tilting device of Figure 32.

### **DESCRIPTION OF THE ILLUSTRATED EMBODIMENTS**

Referring to the drawings, in which like numerals indicate like features, a non-limiting example of a first embodiment of a container handling system in accordance with the invention is illustrated in Figures 1 to 22. The system aims to provide a container handling system which allows containers to be freely moved from road trailers to rail wagons, and vice versa, with complete interchangeability. The container handling system further aims to provide discharge functionality irrespective of whether the containers are being carried on a road trailer or rail wagon.

The container handling system is described herein as a bulk material handling system. It must be understood that the term bulk material is used to describe unpacked goods, such as grain, ores, coal, sand, gravel and stone, for example, that are generally transported in loose bulk form. Although it is envisaged that the system could be particularly useful in handling bulk material it must be understood that it is not limited to this particular application and that any other type suitable stock could be transported and discharged using the system in accordance with the invention. The word handling should be interpreted to include the loading, transport and discharge of the material.

Figure 1 shows an exploded view of a sub-system 10 of the container handling system of the invention in which a container 12 is transported by road. The sub-system 10 further includes a cradle 14 and a carriage 16. In use, the container 12 is locked onto the cradle 14 which is in turn carried pivotally by the carriage 16 to allow the cradle to be pivoted relative thereto during discharging of the bulk material transported in the container. The word carriage is used in its broad sense to include any means of conveyance, thereby covering both a truck drawn trailer as well as a train wagon. However, in the sub-system 10 illustrated in Figure 1 the carriage 16 is in the form of a truck drawn trailer.

-18-

Still referring to Figure 1 it can be seen that the container 12 is a side discharge container in that it has a door 18 in one of its sidewalls extending along the longitudinal length of the container. In the accompanying drawings the sidewall in which the door is located is indicated by the reference numeral 20.1 while the opposing sidewall is indicated by the numeral 20.2.

In Figure 2 the door 18 is shown in its open position wherein bulk material is allowed to be discharged through an opening 22 in the sidewall 20.1 of the container. The door 18 is hinged to the container sidewall 20.1 at its end which is, in use, its lower end by a hinge 24. The other end of the door 18 has a door extension plate 26 in order to increase the overall distance which the bulk material travels over the door when it is discharged from the container. When in its open position the door 18 rests on supports or rollers 28 (shown in Figure 1) carried by the carriage 16. By increasing the overall height of the door 18 using the extension plate 26, the actual discharge point where the bulk material is discharged from is moved further away from the wheels 30 of the carriage. This in turn, creates space for the discharging of bulk material next to the carriage 16. The length of the extension plate 26 will be determined by operational needs to obtain the desired material trajectory during discharge.

Returning now to Figure 2 it can be seen that the container door 18 has upstanding side skirts 32 located at its longitudinally opposed ends to prevent the material from spilling sideways during discharging. The profile of the side skirts can be seen in Figure 3 which shows a side view of the door 18. The container 12 further includes profiled vertical supports 34 which provide storage space for the door skirts 32 when the door 18 is in its closed position. The door skirts 32 are received in the gaps between the vertical supports 34 and the longitudinally spaced apart end walls 20.3 and 20.4 of the container.

Turning now to Figure 4 which shows cross-sectional side views of the container 12 with the door in its open and closed positions, it can be seen

-19-

that the container has a sloped floor 36. The floor 36 slopes upward, at least over a major part of its width, towards the sidewall 20.1 in which the container door 18 is located. The door hinge 24 is located at the top of the sloped floor to raise the hinge point above the lowest point of the container where dust particulates collect. The sloped floor 36 also creates a space between it and a bottom wall 38 of the container in which a self-locking door mechanism 40 is at least partially located.

The door mechanism 40 is operable between a first, locked position wherein the container door is closed and locked, and a second, unlocked position wherein the container door is open to discharge the bulk material. Figure 4 shows the door mechanism 40 in its locked and its unlocked positions.

As can be seen in Figure 4, the door mechanism 40 includes a first or top L-shaped actuating link 42. The arm of the link 42, which is the shorter arm, is connected to the container 12 using a pivot pin 44.1. The door mechanism 40 further includes a second or lower link 46 which is also referred to as a connecting link and which is connected to the top actuating link 42 at one end using a pivot pin 44.2. The other end of the connecting link 46 is pivotally connected to a first intermediate link 48 by means of a pin 44.3. The first intermediate link 48 is connected to a second link 50 which is, in turn, connected to a rear actuating link 52. The links 48, 50 and 52 are also pivotally connected to one another by means of pivot pins 44.4 and 44.5. The other end of the rear actuating link 52 is pivotally connected to the wall 20.2 of the container 12 by means of pivot pin 44.6.

From Figure 4 it must be clear that the top link 42 is pivoted between a first and second position when the door mechanism 40 is manipulated between its closed and open positions. The first position of the top link corresponds with the closed position of the door mechanism while the second position corresponds with the open position of the door mechanism. When the top link 42 is in its first position the door is forced closed by means of a roller 53 carried on the arm of the top link which is the longer arm. In contrast, when

-20-

the top link is in its second position the door 18 is allowed to be opened. In use, the weight of the door 18, and the weight of the material inside the container when filled, will act on the door to open it when the top link is moved from its first position to its second position.

In this embodiment of the container 12 the door mechanism 40 can be manipulated between its open and closed positions in two ways. The first option is to move the first intermediate link 48, which is also referred to as a drive link, back and forth while the second option is to pivot the rear actuating link 52 by lifting its end which is, in use, its lower end. The intermediate link 48 is, in use, driven by an actuating mechanism located on the cradle 14, whereas the rear actuating link 52 is lifted by a container tilting device. Both methods of manipulating the door mechanism 40 are described in greater detail below.

In the preferred embodiment of the invention the door mechanism 40 further includes a pre-tensioning device 54 for adjusting the tension between the top link 42 and the connecting link 46. The tensioning device 54 is shown in detail in Figure 5. From this figure it can be seen that the device 54 includes a wedge 56 having an internal thread into which a bolt 58 is threaded. In use, the wedge 56 wedges against the pivot pin 44.2 connecting the first and second actuating links. The pin 44.2 in turn runs in an elongate hole 60 extending through the connecting link 46 so that it is moved along the hole as the wedge 56 is adjusted by turning the bolt 58. It must be understood that by adjusting the tensioning device 54 the friction between the top link 42 and the connecting link 46 is adjusted to adjust the resistance against the opening and closing of the door 18.

Figure 5 shows different positions of the wedge 56 during the tensioning of the device 54.

An alternative embodiment of the pre-tensioning device is shown in Figure 6 and indicated by the numeral 254. In this embodiment the connecting link 46 comprises an adjustable tube assembly 256. The tube assembly 256

-21-

includes two bushes 258.1 and 258.2 which are, in use, a top and bottom bush respectively. The top bush 258.1 connects a tube 260 to the top link 42 using the pin 44.2. Similarly, the bottom bush 258.2 connects the tube 260 to the first intermediate link 48. As can be seen in Figure 6, the bushes 258.1 and 258.2 are movably and removably connected to the links 42 and 48 respectively. In the illustrated embodiment of Figure 6 the top bush 258.1 carries external thread 262 which, in use, engages internal thread of the tube 260. The bottom bush 258.2 in turn carries a spigot 264 which is, in use, received in the tube 260. The spigot and tube are dimensioned so as to allow the tube to rotate about the centre axis of the spigot.

The tensioning device 254 further includes a locking pin 266 which is used to lock the tube 260 to the bottom bush 258.2 i.e. prevent rotation between the tube and spigot. A hole 268 extends through the bush 258.2 and two holes 270 extend, at right angles to each other, through the tube 260. To lock the tube to the bottom bush the hole 268 is aligned with one of the holes 270 so that the locating pin 266 can be received in the aligned holes, thereby to obstruct rotation between the bottom bush and the tube. It must be understood that by pulling out the pin 266 the device 254 is unlocked to allow rotation of the tube 260. The pin 266 can then be inserted into any one of a series of holes 272 located in the sidewall of the tube 260 and used to rotate the tube, which in turn screws or un-screws the threaded top bush to lengthen or shorten the tube assembly. In the illustrated embodiment the series of holes 272 is arranged so as to allow the pin 266 to be received therein from the front, i.e. when standing in front of the front wall 20.1 of the container 12, at any rotation.

From the above description of the tensioning device 254 it must be understood that the effective length of the connecting link 46 between the links 42 and 48 can be adjusted by rotating the tube 260.

The cradle 14 will now be described in greater detail with reference to Figure 6. The cradle 14 includes two longitudinally extending beams 61.1 and 61.2. A number of laterally, spaced apart supports are connected

-22-

between the beams 60.1 and 60.2. In the illustrated embodiment, the cradle 14 includes four supports 62.1 to 62.4 with the two end supports 62.1 and 62.4 being connected to the ends of the beams 60.1 and 60.2. Two upstanding members 64.1 and 64.2, each carrying a pivot connector 66, are located on the end supports 62.1 and 62.4.

The pivot connectors 66 are complementally shaped to pivot connectors 68 (Figure 1) located on the carriage 16 so that, in use, the complementally shaped pivot connectors engage one another when the cradle is mounted on the carriage. In the illustrated embodiment, the pivot connectors 66 on the cradle 14 are in the form of stub shafts while the pivot connectors 68 on the carriage 16 are in the form of sockets provided in a frame 70. The shafts 66 are pivotally received in the sockets 66 to allow the cradle 14 to pivot relative to the carriage 16.

Returning now to the cradle 14 shown in Figure 7, at least one of the laterally extending supports 62.2, 62.3 houses a door actuating mechanism 72. In the preferred embodiment, both supports 62.2 to 62.3 house a door actuating mechanism 72 to engage both door mechanisms 40 on the container 12.

An example of the door actuating mechanism 72 can be seen in Figure 8, which shows a cross-sectional view through the cradle 14 and container 12. Figure 8 shows the container 12 both connected to and disconnected from the cradle 14, thereby also illustrating the act of mounting the container on the cradle.

The actuating mechanism 72 includes movable engaging means 74 carrying an engaging formation 76 for engaging a complementally shaped engaging formation 78 carried on the first intermediate or drive link 48. The movable engaging means 74 is illustrated as a wheeled trolley from which the engaging formation 76 extends. From Figure 8 it can be seen that the engaging formation 76 is held captive by the engaging formation 78 when the container 12 is mounted on the carriage 14.

-23-

An actuator 80 is mounted inside the support and used to move the wheeled trolley 74 forwards and backwards between different positions along the support. It must be understood that one end of the actuator 80 is fixed to the cradle 14 while the other end is connected to the wheeled trolley 74. In use, the engaging formations 76 and 78 engage each other to cause the intermediate link 48 to move back and forth through actuation of the actuator 80 in order to manipulate the top link 42 between its different positions, thereby opening and closing the container door 18. Figure 9 illustrates the act of opening the container door 18 by manipulating the door mechanism 40 by using the actuator 80.

Returning to Figure 7, the upstanding engaging formation 76 of each actuating mechanism 72 extends through a slot 82 provided in each of the supports 62.2 and 62.3 so that it is located outside the support where it can engage the corresponding engaging formation 76 of the door mechanism 40.

Still referring to Figure 7 it can be seen that the cradle 14 further includes connecting formations 84 provided on the end supports 62.1 and 62.4 onto which actuators 86 acting between the cradle and carriage are, in use, connected. One of the actuators 86 can be seen in Figure 10 which illustrates the tilting action of the cradle 14 relative to the carriage 16. In this figure the cradle 14 is shown halfway between its flat, transporting position and its titled, discharging position. It must be understood that the container 12 is tilted together with the cradle 14 as it is connected thereto using container twist locks 88.

Although the method of discharging the bulk material from the container 12 should be clear from the above description it will now be describe briefly with reference to Figures 11 and 12.

The different stages of the material discharge process are illustrated in Figure 11. After transporting the container 12 to the discharge site the

-24-

container door 18 is opened by actuating the actuators 80 to manipulate the door mechanisms 40 from their closed positions into their open positions. Next, the cradle 14 together with the container 12 thereon is tilted by actuating the actuators 86 so that the container is pivoted relative to the carriage 16. Once the material has been discharged from the container 12 the door 18 is closed by actuating the actuators 80 and the cradle is moved back into its transporting position by actuating the actuators 86. When the container door 18 returns to its closed position it is automatically locked. The carriage 16 is then transported away from the discharge site to allow the next container to be discharged.

Although the steps of the method of discharging the container 12 have been set out in the preferred order it must be clear that they do not necessarily have to be carried out in the specific order described above. For example, after having discharged the container 12 the cradle 14 can be lowered back into its transport position before the container door 18 is closed.

The sub-system 10 aims to position the centre of gravity 90 of the bulk material being discharged between the longitudinal centre line of the carriage 16 and the sidewall 20.2 of the container 12 opposite the discharge side 20.1 for a major part of the discharge process. It must be understood that by keeping the centre of gravity 90 of the bulk material in the central region of the container between its side walls 20.1 and 20.2 for the majority of the discharge process the risk of the container, cradle and carriage tipping over during discharging is reduced significantly. Figure 12 shows the position of the centre of gravity 90 during different stages of the discharge process. At the different stages shown in Figure 12 the centre of gravity of the bulk material is located on the side of the longitudinal centre line opposite to the discharge side. This is achieved by the careful positioning of the pivot axis 92 about which the cradle 14 pivots during the discharge process.

-25-

Another advantage of using the sub-system 10 is that there is no need for large containing tipping machines, thereby reducing costs significantly.

The container handling system in accordance with the invention further includes a sub-system 100 for the handling and discharge of containers when carried by rail. It is envisaged that this sub-system would find particular application in discharging containers carried on train wagons and is illustrated in Figure 13. As mentioned above, like numerals indicate like features.

Figure 13 shows two containers 12 being carried by a train wagon 102. The containers 12 are substantially the same as the one described above with reference to the sub-system 10 and will therefore not be described in detail. Instead of having a movable cradle such as that of the sub-system 10, the sub-system 100 includes three frame sections mountable on the wagon bed 104. Two frame sections 106.1 and 106.2 are mounted at the longitudinal ends of the wagon bed 104 and the third frame section 106.3 at the centre thereof. The two end frame sections 106.1 and 106.2 each has one pivot connector in the form of a socket 108 for engaging a complementally shaped pivot connector in the form of a stub shaft 110 carried by the container 12. The centre frame section 106.3 has two sockets 108 for engaging both containers 12 mounted on the wagon 102.

To discharge the bulk material in the containers 12 mounted on the wagon 102 there is also provided for the system 100 to include a container tilting device 112. The container tilting device 112 can be seen in Figure 14 in which it is shown in the process of tipping a container.

The device 112 has a wheeled base 114 so that it can move between different locations. In the illustrated embodiment the device 112 runs on rails 116 substantially parallel to the rails 118 on which the wagon 102 runs. This allows the tilting device 112 to be moved back and along its rails to discharge the bulk material from multiple containers 12. Figure 15 shows the location of the tilting device 112 relative to the container 12 mounted on

-26-

a rail wagon 102 as it is transported past it. The movable tilting device 112 allows for the discharge of containers mounted on the rail wagon 102 in motion i.e. without the need to bring the wagon to a standstill. It is envisaged that the tilting device 112 could move with the wagon while busy tilting a container 12 mounted on the wagon. It is believed that this will significantly reduce the time required to discharge bulk material at a tipping station, for example.

The tilting device 112 includes a coupling mechanism 120 which, in use, couples onto the rear opening link 52 of the container 12 and is operable to pivot the link about its pivot point 44.6. The coupling mechanism 120 includes a slide 122 and a swing bar 124 connected to the slide through a tie 126. The tie 126 is pivotally connected between the slide 122 and swing bar 124 so as to allow the swing bar to move in an arc relative to the slide. The swing bar 124 carries a coupler 128 which, in use, couples to a bar 130 the rear opening link 52 of the container 12 as shown in Figure 16. The coupler 128 is in the form of a hook in which the bar 130 is received when the coupler engages the link 52.

Still referring to Figure 16, it can be seen that the swing bar 124 carries a shackle 132 to which a rope 134 is in use connected in order to lift the swing bar and slide 122.

The slide 122 is movable along a first axis of movement which is arranged substantially vertically so as to allow the slide to move upwards and downwards on a primary vertical support 136 using a lifting system. For the sake of clarity the slide 122 is also referred to as a vertical slide seeing that it moves vertically in use. The lifting system includes a series of pulleys over which the rope 134 in use runs in order to lift or lower the vertical slide 122. As shown in Figure 14 the rope 134 runs from the vertical slide 122 over a pulley 138.1 located on top of the primary vertical support 136. From there it runs over a pulley 138.2 mounted on top of a secondary vertical support 140 and over a pulley 138.3 before it is secured to a cross-beam 142 spanning between the primary and vertical supports. A second rope

-27-

144 is connected at one end to the underside of the swing bar 124 and runs over pulleys 138.4 and 138.5 (Figure 22) located under and at the edges of the base 114. From the pulley 138.5 the rope 144 runs over a pulley 138.6 mounted on the secondary support 140 before it is fixed on the base 114.

To allow the vertical slide 122 and accordingly to swing bar 124 to move up and down the primary support 136, the pulleys 138.3 and 138.6 are mounted on a trolley 146. Figure 17 shows an exploded view of the trolley mounted to the secondary vertical support 140. From this figure it can be seen that the secondary vertical support 140 includes two parallel longitudinal members 140.1 and 140.2, shown as I-beams in the accompanying drawings. Two transverse members 140.3 and 140.4 extend between the top and bottom ends of the longitudinal members. The trolley 146 has a box-shaped body 148 to which two wheels 150 are connected. The wheels 150 run between the flanges of the I-beams 140.1 and 140.2 so that the trolley is allowed to run smoothly up and down the beams. The wheels 150 secure the top end of the body 148 to the vertical support 140 while two pairs of guides 152 secure the lower end to the vertical support, thereby ensuring that the vertical slide can only move along the longitudinal axis of the vertical support 140.

In the trolley 146 the position of the wheel 138.3 is fixed while the position of the pulley 138.6 is adjustable. To ensure that the pulley 138.6 is movable it is mounted in a slide box 154, which is slidable along the length of the trolley body 154. A tension member in the form of a compression coil spring 156 urges the slide box, and therefore the pulley 138.6, upwards. The spring 156 acts as a rope tensioning device to ensure that the rope is always taut.

Still referring to Figure 17 it can be seen that the invention further includes hydraulic linear actuators 158 to move the trolley up and down the secondary vertical support 140. The actuators 158 are connected between the body 148 of the trolley and the transverse section 140.4 located at the bottom end of the vertical support. Both ends of each actuator 158 carries a

-28-

clevis type connector 160 which connects to a corresponding connector 162.

From the above description of the trolley 146 it must be understood that the vertical slide 122 and swing bar 124 are moved by moving the trolley up and down the secondary vertical support 140 by extending and contracting the actuators 158. In particular, the vertical slide 122 is lifted by moving the trolley 146 downward i.e. by contracting the actuators 158. It follows naturally that the vertical slide 122 is lowered by moving the trolley 146 upward i.e. by extending the actuators 158.

It must be understood that the pulley system described above increases the rope travel by a factor of two. The two ropes 134 and 144 work together with the one paying rope out as the other is reeling it in. The coil spring 156 also allows for an increase in apparent rope length as the swing bar moves outward.

In order to pivot the swing bar back and forth away from and towards the location of the container 12, the tilting device 112 includes an actuating mechanism 164 shown in Figure 18. The actuating mechanism 164 has a catch 166 defining a recess 168 in which a portion of the swing bar 124 is received when the catch engages the swing bar. Figure 18 illustrates the movement of the catch 166 between its two extreme positions along a second axis of movement, which is substantially horizontal in use. A linear actuator 170, again in the form of a hydraulic actuator, is used to move the catch 166 between its two extremes. As shown in Figure 18, the actuator 170 is extended in order to move the catch towards the container 12 mounted on the rail wagon 102, and contracted to move it away from the container 12. It must be understood that the swing bar 124 and, accordingly, the hook 128 which engages the container 12 are pivoted towards the container as the catch 166 is moved towards the container i.e. when the actuator 170 is extended. In the illustrated embodiment the catch 166 is moved in a horizontal direction. To facilitate movement of the catch

-29-

166 it has wheels 172 which run along a channel 174 (Figure 14) extending along the horizontal direction.

The method of discharging the bulk material being transported in the containers 12 mounted on the rail wagon 104 using the tilting device 112 will now be described in greater detail with reference to Figures 19 to 22.

The train wagon 104 carrying the container 12 in which the bulk material is being transported is moved into position next to the container tilting device 112. With or without stopping the wagon 102 the tilting apparatus 112 is moved alongside the wagon 102 and, accordingly the containers 12 mounted thereon. The vertical slide 122 is lowered so that the catch 166 on the actuating mechanism 164 engages the swing bar 124. Next, the actuator 170 is extended to move the hook 126 towards the container 12 until the hook is position below the bar 130 carried by the link 52. The actuators 158 are contracted so as to move the trolley 146 down the secondary support 140, thereby lifting the hook 126 to engage the bar 130. The act of engaging the hook 126 and bar 130 is illustrated in Figure 19. When the hook 126 engages the bar 130 the actuators 170 are contracted further to lift the vertical slide and therefore the hook 126, thereby pivoting the link 52 away from the sidewall 20.2 to open the door 18 as described above. The step of pivoting the link 52 and opening the door is illustrated in Figure 20.

It is envisaged that before the step of pivoting the link 52 away from the wall 20.2 can be carried out it could be required to unlock the link 52 first. The step of unlocking the link 52 so that it can be pivoted is illustrated in Figure 21. From this figure it can be seen that the container 12 has a locking formation 176 which engages a recess 178 in the link 52 when the link is in its closed position. In order to unlock the link 52 it must be lifted so as to lift the recess off the locking formation 176 or, in other words, to release the link from the locking formation. When releasing the link 52 from the locking formation 176 its pivot shaft is also lifted. This is made possible by the inclusion of a pivot link 180 which connect to the shaft 44.6 and

-30-

pivots about an axis 182. It must be understood that the locking formation 176 automatically locks the link 52 and, therefore the door 18, when the door is moved into its closed position after discharge.

Although the locking formation 176 and recess 178 are described to be located on the container and link 52 respectively, it must be understood that the recess could be located on the container and the locking formation 176 on the link 52. The locking formation 176 and recess 178 therefore act as complementally shaped locking formations which lock the door mechanism when they are engaged. The locking formation on the link 52 could also be located on either the first or second intermediate links 48 and 50.

Returning now to the method of discharging the bulk material from the container 12, once the door 18 has been opened the vertical slide is lifted further so as to tip the container 12. When being tilted the container 12 pivots about the pivot points 108. From Figure 22 it can be seen that as the vertical slide 122 is being lifted, the coupling mechanism 120 is disengaged from the actuating mechanism 164. During the lifting of the vertical slide 122 the rope 134 is guided by means of a rope guide or deflector 184 (shown in Figure 14). The rope guide 184 is pivotal about the point 186 and carries a guide wheel 188. In use, the rope guide ensures that the rope 143 stays more or less vertical and the direction of the force on the swing arm 124 remains favourable during the entire lifting stroke.

After all of the bulk material has been discharged from the container 12 the vertical slide 122 is lowered to pivot the container 12 from its discharge position back into its transport position. As described above the vertical slide is lowered by extending the actuators 158 so as to move the trolley 146 upwards. As the vertical slide 122 is lowered, the swing bar 124 again engages the catch 166 of the actuating mechanism 164. Thereafter, the actuator 170 is extended to cause the catch to move towards the container 12, thereby pivoting the rear link 52 back towards the container. This causes the door mechanism 40 to close the container door 18. The door is automatically locked as the locking formation 176 is received in the recess

-31-

178 in the link 52. Once the container door 18 is locked in its closed position the actuator 170 is contracted to move the catch 166 away from the container 12, thereby decoupling the coupler hook 126 and the bar 130. Thereafter, the tilting device 112 is moved to the second container mounted on the rail wagon 104 and the above method of discharging the bulk material is repeated.

It is believed that more than one containing tilting device 112 could be used in series on the same set of rails 116 so that multiple containers 12 can be discharge simultaneously.

From the above description it should be clear that the same advantages described above with reference to the use of the sub-system 10 are achieved when using the sub-system 100. The description of the position of the centre of gravity during the course of the discharge process with reference to the sub-system 10 applies to the discharge process of sub-system 100.

It must be understood the both sub-systems 10 and 100 form part of the holistic bulk material handling system wherein the bulk material may be transported by rail only, from rail to road, from road to rail or from road to rail to road again. The interchangeability of the components in the sub-systems 10 and 100, for example the container 12 which may be carried on the truck trailer 16 or the wagon 104, allows for easy integration of different forms of transport. By using the sub-systems 10 and 100 in a holistic system there is no longer need to transfer bulk material from one type of container to another when switching between different forms of transportation. Instead, if it is required to switch between different types of transport, the containers 12 can simply be dismounted from one type of carriage, for example the trailer 16, and mounted on another type of carriage, for example the rail wagon 104, while fully loaded with bulk material. Irrespective of type of transport the containers 12 can easily be discharged as they allow for two different methods of actuating the door mechanisms 40 as described above. Another significant advantage of the

-32-

system in accordance with the invention is a container can be discharged using either method while still being mounted on the carriage. It is believed that the system in accordance with the invention therefore also reduces the number of times a particular container is handled during the loading, transport and discharge phases. It is further believed that the use of a side discharge container simplifies the discharge phase as the bulk material is not being discharge in line with the direction of travel of the carriage.

Referring now to Figures 23 to 39 of the accompanying drawings, in which like numerals indicate like features, a non-limiting example of a second embodiment of a container handling system in accordance with the invention will be described. Again, the system includes a sub-system 300 for the handling and discharging of containers when carried by road and a sub-system 400 for the handling and discharging of containers when carried by rail.

Figure 23 shows an exploded view of the sub-system 300. In this system a container 302 for carrying bulk material is mounted directly on the carriage 16, which is illustrated as a truck drawn trailer. In this second embodiment the container 302 is again carried pivotally on the trailer 16 but without the use of a cradle. Instead, the container 302 is mounted directly onto lateral supports 304.1 to 304.4 which are fixed to the chassis of the trailer 16. In transit, the container 302 is secured on the trailer 16 by means of standard twist locks used on shipping containers. The lateral supports 304 each carry a male twist lock 306 at their longitudinally opposed ends for engagement with the female corner castings 308 located on the container 302.

Similarly to the first embodiment the container 302 is again a side discharge container. The container 302 is substantially similar to the container 12 of the first embodiment and, accordingly, only the most significant differences will be described in detail.

-33-

From Figure 25 it can be seen that, due to the exclusion of the cradle from the second embodiment, the pivot connectors 310 are now located on the container 302 directly for engagement with the complementally shaped pivot connectors 312 of the trailer. The pivot connectors 310 on the container 302 are in the form of shafts while the pivot connectors 312 on the trailer 16 are in the form of sockets provided in an upstanding frame 314. In this second embodiment the upstanding frames 314 are again mounted directly to the chassis of the trailer. When the container 302 is mounted on the trailer 16 the pivot shafts 310 are received pivotally in the sockets 312 to allow the container to be pivoted relative to the trailer 16.

Unlike the first embodiment where the container 12 is received between the upstanding frames 70, in this second embodiment the upstanding frames 314 are received in cavities 316 defined by box-like support structures 318 of the container 302. It must be understood that the upstanding frames 314 extend through the floor of the container 302 and into the structures 318 when the container is being transported on the trailer. The main advantage of this container mounting arrangement of the second embodiment is that the maximum container length that can be transported by the trailer is not determined by the distance between the upstanding frames 314. In other words, containers of different lengths could be transported on the trailer seeing that the upstanding frames 314 do not provide absolute limits between which the container must fit when mounted on the trailer.

The container further has two ties 320 running between its box-like structures 318 and its sidewall 20.2. The ties 320 are included to resist bulging of the container walls, in particular the sidewalls 20.1 and 20.2, while carrying bulk material.

The door mechanism of the container 302 is also simplified in order to include less movable parts than the door mechanism 40 of the container 12 of the first embodiment. The door mechanism of the container 302 is indicated by the numeral 322 in Figure 26 in which it is illustrated in its locked and its unlocked positions. Similarly to the first embodiment the door

-34-

mechanism 322 is operable between a first, locked position wherein the container door is closed and locked, and a second, unlocked position wherein the container door is open to discharge the bulk material.

As can be seen in Figure 26, the door mechanism 322 includes a first or top L-shaped actuating link 324. The arm of the link 324, which is the shorter arm, is connected to the container 302 using a pivot pin 326.1. The door mechanism 322 further includes a connecting link 328 which is connected to the top actuating link 324 at one end using a pivot pin 326.2. The other end of the connecting link 328 is pivotally connected to an intermediate link 330 by means of a pin 326.3. The intermediate link 330 is, in turn, connected to a drive link 322, again by means of a pivot pin 326.4.

Similarly to the first embodiment, the top link 324 is pivoted between a first and a position when the door mechanism 322 is manipulated between its closed and open positions. The first position of the top link corresponds with the closed position of the door mechanism while the second position corresponds with the open position of the door mechanism. When the top link 324 is in its first position the door is forced closed by means of a roller 333 carried on the arm of the top link which is the longer arm. In contrast, when the top link is in its second position the door 18 is allowed to be opened. In use, the weight of the door 18, and the weight of the material inside the container when filled, will act on the door to open it when the top link is moved from its first position to its second position.

The door mechanism 322 is manipulated between its open and closed positions by causing the drive link 332 to be moved back and forth in a channel located below the floor of the container. From Figure 26 it can be seen that the drive link moves substantially linearly when being manipulated to open and close the door. In order to manipulate the drive link 332 it carries two engagement formations 334 and 336 for engagement with complementally shaped engagement formations located on an actuating mechanism located on the trailer 16 and a container tilting device respectively. The engagement formation 334 is typically used when

-35-

discharging a container 302 carried on the trailer 16 while the engagement formation 336 is typically used when discharging a container carried on a train wagon. Both methods of manipulating the door mechanism 322 are described in greater detail below.

Returning to the door mechanism 322, it again includes a pre-tensioning device substantially similar to the pre-tensioning device 254 of the first embodiment and shown in Figure 6. The connecting link 328 again comprises the pre-tensioning device 254. It is envisaged that the pre-tensioning device 254 could be used to adjust the force being exerted on the door 18 when the door mechanism 322 and accordingly the door 18 are in their closed positions. Given the geometrical position of the pivot link 326.2 in relation to the pivot pin 326.1 it is clear that an increase in length of the pre-tensioning device 254 increases the force acting on the door 18 to retain it in its closed position. The length of the pre-tensioning device 254 will typically be increased to counter the effects of wear and tear on the container door 18 so as to ensure that the door closes with sufficient force to prevent any bulk material from escaping during transit.

The sub-system 300 for discharging the container 302 when carried on the trailer includes laterally extending supports or channels 304.3 and 304.4 which each houses at least partially a door actuating mechanism 338 for manipulating the door mechanisms 322. The door actuating mechanism 338 can be seen in Figure 27, which shows a cross-sectional view through the trailer 16 and container 302.

The actuating mechanism 338 includes movable engaging means 340 carrying a jaw 342 in which a connecting pin 344 carried by an actuator 346 is receivable. The connecting pin 344 defines an engaging formation for engaging the complementally shaped engaging formation 334 carried on the drive link 332. As shown in Figure 27, the engagement formation has a slot 348 in which the connecting pin 344 is received when the container 302 is mounted on the trailer 16. The movable engaging means 340 is illustrated as a wheeled trolley carrying the jaw 342. An actuator 350 is

-36-

mounted inside the support 304.3 and used to move the wheeled trolley 340 forwards and backwards between different positions along the longitudinal length of the support. Again, one end of the actuator 350 is fixed to the support 304.3 while the other end is connected to the wheeled trolley 340 such that, in use, extension and contraction of the actuator causes the trolley to move.

Figure 28 illustrates the different stages in the process of opening the container door 18 and discharging the bulk material therefrom.

After transporting the container 302 to the discharge site the container door 18 is opened by manipulating the door mechanisms 322 from its closed position into its open position. This is done by moving the carriage 340 and therefore the drive link 350 in the direction indicated by the numeral 352. As shown in Figure 28(a), the carriage 340 is moved in the direction 352 by actuating the actuator 346, typically a single acting multi-stage hydraulic piston and cylinder assembly. Before actuating the hydraulic cylinder 346 further it is necessary to move the trolley 340 back slightly in the direction indicated by the numeral 354 in Figure 28(b). This step of moving the trolley 340 in the direction 354 is necessary due to the shape of the jaw 342. By moving the trolley 340 in the direction 354 the connecting pin 344 of the cylinder 346 is aligned with the opening in the jaw 340 so as to allow the connecting pin to escape the jaw. With the connecting pin 344 free to move the hydraulic cylinder 346 is extended further to start tilting the container 302 as shown in Figure 28(c). The hydraulic cylinder 346 is extended until the container 302 is tilted completely as shown in Figure 28(d), thereby discharging all of the bulk material from the container.

Once the material has been discharged from the container 302 it is lowered back into its transport position. The container is lowered by releasing the hydraulic pressure of the cylinder 346 so that it is contracted under the force of gravity by the weight of the container. The connecting pin 344 is again received in the jaw 342 as the container 302 is lowered back into its transport position. In order to close the door 18 the actuator 350, typically a

double acting hydraulic piston and cylinder assembly, is extended to move the trolley 340 in the direction 354 until the door is completely closed.

Similarly to the first embodiment, the container door 18 is automatically locked upon its return to its closed position. Automatic locking is achieved by over-centring the link 328. The term over-centre is used to describe the act of pushing the operatively lower end of the connecting link 328 beyond a position wherein the link is vertical when closing the container door 18. The over-centre position of the link 328 is shown in detail in Figure 27. From this figure it can be seen that a slide or wheel 356 carrying the lower end of the link 328 is pushed beyond a ridge ornock 358 formed in the surface on which it moves. The centre of the wheel 358 is moved about 10mm past the nock 358 so that the link 328 is angled slightly backward in order lock the door mechanism 322 in its closed position. As a result of the backward angled link 328 an external force sufficient to move the wheel 356 back over the nock 358 is required in order to move the door mechanism into its open position.

The different stages of tilting the container 302 during the discharge process are illustrated in Figure 29 while the position of the centre of gravity of the body of bulk material during the discharge process is illustrated in Figure 30. The same advantages of the sub-system 10 are achieved by using the sub-system 300 and, accordingly, will not be discussed again. It is however worth mentioning that the sub-system 300 provides several additional advantages. For example, the door mechanism 322 is simplified to include less movable parts thereby reducing maintenance. Also, by locating the connecting pin 344 in the jaw 342 allows for a single connection point on the container 302. Another advantage of the sub-system 300 and in particular its door and actuation mechanisms is that the two actuators 346 and 350 can be operated at the same time during the discharge process to open the door 18 in a controlled manner. For example, by operating both actuators simultaneously the actuator 350 could effectively be used as a brake to prevent the door 18 from collapsing to its open position under the force of the bulk material. This could not only

-38-

allow for controlled discharge of the bulk material but could also prevent the door from being damaged by slamming into the trailer for example should it simply collapse under the weight of the bulk material.

The container handling system in accordance with the second embodiment of the invention further includes a sub-system 400 for the handling and discharge of containers when carried by rail. It is envisaged that this sub-system would find particular application in discharging containers carried on train wagons as illustrated in Figure 31. As mentioned above, like numerals indicate like features.

Figure 31 shows two containers 302 being carried by a train wagon 102. The containers 302 are substantially the same as the one described above with reference to the sub-system 300 and will therefore not be described in detail. Similar to the sub-system 300 there are a number of lateral supports 402.1 to 402.6 mountable on the wagon bed 104. The lateral supports are securable on the wagon bed 104 by means of container twist locks 404. In order to mount the two containers 302 on the wagon bed 104 four of the lateral supports carry frame sections 314 similar to those described above with reference to the sub-system 300. Again, the pivot connectors 310 of the containers 302 are received in the sockets 312 of the frame sections 314 when the containers are mounted on the wagon bed 104. The lateral supports 402.2 and 402.5 provide support surfaces for supporting the underside of the containers 302 when mounted on the wagon bed 104, thereby preventing the underside from bulging under the weight of the bulk material. The lateral supports 402.2 and 402.5 also provide gripping locations for a container tilting device 406.

The container tilting device 406 can be seen in Figure 32 which shows a perspective view of thereof. The device 406 has a wheeled base 408 so that it can move between different locations. Similarly to the tilting device 112 of the first embodiment, the tilting device 406 runs on rails substantially parallel to the rails on which the wagon 102 runs.

The tilting device 403 includes two coupling mechanisms 410 which, in use, couples onto the rear engagement formations 336 of the door mechanisms 322. The coupling mechanisms 410 are operable to move the door mechanisms 322 from their closed positions into their open positions and to lift the container 302 in order to discharge the bulk material therefrom.

A perspective view of one of the coupling mechanisms 410 is shown in Figure 33. The coupling mechanism 410 includes vertical slide 412 and a bar 414 which is carried by the vertical slide in a manner allowing the bar to be movable with respect to the vertical slide in a direction substantially perpendicular to the direction of travel of the vertical slide. In the embodiment illustrated in the accompanying drawings the bar 414 is movable in a substantially horizontal direction with respect to the vertical slide 412. It must however be understood that the bar 414 is also movable vertically as it is carried by the vertical slide 412. The bar 414 carries a coupler 416 which, in use, couples to the engagement formation 336 of the drive link 332 of the container 302. The coupler 416 is illustrated as a hook in which the engagement formation 336, which is in the form of a connecting pin or bar, is received when the coupler engages the drive link 332. Due to the bar 414 being movable in two directions of movement, e.g. vertical and horizontal in the accompanying drawings, the hook 416 is allowed to move in an arc 418 (Figure 34) to discharge the bulk material from the container 302.

The vertical slide 412 is movable upwards and downwards on a primary vertical support which has two upright channel sections 420.1 and 420.2, the operatively lower ends of which are connected to the base 408 while the operatively upper ends are connected to one another by a cross-bar 422. Arcuate supports 424.1 and 424.2 extend from the cross-bar 422 and bolt to the base 408 to provide further structural support to the upright channel sections 420.1 and 420.2. The vertical slide 412 is movable upward and downward by means of a lifting system 426 which operate substantially between the upright channel sections 420.1 and 420.2. The lifting system includes a trolley 428, the wheels 430 of which run inside the

-40-

channel sections 420.1 and 420.2. To move the trolley 428 up and down the channel sections 420.1 and 420.2 the lifting system includes two actuators 432 mounted between the base 408 and the trolley 428. The actuators are typically in the form of a double acting hydraulic piston and cylinder assemblies. The hydraulic cylinders 432 are arranged substantially parallel to the upright channel sections 42.1 and 420.2 and are in use extended to lift the trolley 428 and contracted in order to lower the trolley.

Referring now to Figure 35 it can be seen that the vertical slide 412 also includes four wheels 434 which in turn run inside two upright channel sections 436.1 and 436.2 of the trolley 428 to allow it to move relative to the trolley 428 while the trolley is being lifted or lowered. In order to move the vertical slide 412 relative to the trolley 428 when the trolley is lifted or lowered the lifting system 426 includes a flexible drive means running from the vertical slide 412 over a series of pulleys and back to the vertical slide. In the illustrated embodiment the flexible drive means is in the form of two separate chains 438.1 and 438.2. Each chain runs from the vertical slide 412 over a pair of sprockets 440 located at the operatively upper end of the trolley 428 and back down over a second pair of sprockets 442 located at the operatively lower end of the trolley 428 before running back to the vertical slide. It must be understood that the drive system 426 described above increases the travel of the vertical slide 412 by a factor of two with respect to the travel of the trolley 428. The drive system 426 thereby allows the vertical slide 412 to reach its uppermost position at the top of the channels sections 436.1 and 436.2 when the hydraulic cylinders 432 are extended and its lowermost position at the bottom of the channel sections 436.1 and 436.2 when the hydraulic cylinders 432 are contracted.

Returning to Figure 34, the vertical slide 412 further includes four wheels or pulleys 440 which allows for guided movement of the bar 414 in a substantially horizontal direction, in use. The bar 414 is in the form of an I-beam which has locating ridges 442 running longitudinally along its flanges 444. In use, the locating ridges are received in annular grooves in the

-41-

pulleys 440 to ensure that the bar 414 moves substantially linearly when moving in the horizontal direction.

The coupling mechanism 410 further includes an actuating mechanism 446 to move the bar 414 back and forth away from and towards the location of the container 302, i.e. in a substantially horizontal direction. The actuating mechanism 446 has a catch 448 defining a recess 450 in which a portion of the bar 414 is received when the catch engages the bar. Referring in particular to Figure 34, it can be seen that the end of the bar 414 opposite the end where the hook 416 is located carries a roller 452 which is received in the opening 450 when the catch engages the bar. A linear actuator 454, again in the form of a double acting hydraulic piston and cylinder assembly, is used to move the catch 448 between its two extremes. The hydraulic cylinder 454 is extended in order to move the catch away from the container 302 mounted on the rail wagon 102, and contracted to move it towards the container 302. In the illustrated embodiment the catch 448 is moved in a horizontal direction through extension and contraction of the hydraulic cylinder 454. To facilitate movement of the catch 448 it again has wheels 456 which run on opposite sides of flanges 458.1 and 458.2 of two channel sections 460.1 and 460.2 extending along the horizontal direction. The flanges 458.1 and 458.2 again carry upstanding ridges 462 which are received in grooves of the wheels 456 to guide the catch 448 during movement. In Figure 34 it can be seen that the channel sections 460.1 and 460.2 are fixed to the base 408 by means of two brackets 464.1 and 464.2.

The channel sections 460.1 and 460.2 are spaced apart from one another to define an opening in the form of a slot between them through which a portion 466 of the catch 448 extends. This portion 466 is used to attach an end of the hydraulic cylinder 454 to the catch for 448, typically by means of a clevis connector 468 carried by the end of the hydraulic cylinder 454.

Returning now to Figure 32 it must be understood that each container tilting device 406 has two coupling mechanisms 410 which are mounted parallel to one another on the base 408. The coupling mechanisms for 10 are

-42-

spaced apart so that the distance between hooks 416 is substantially equal to the distance between the door mechanisms 322 of one container 302. In use, the hooks 416 engage both bars 336 of the container 302 when tilting the container.

Referring still to Figure 32, the container tilting device 406 also includes a gripping device 470 for gripping or holding the railway wagon 102 during the discharge process. The gripping device 470 is located between the two coupling mechanisms 410 so that it is substantially aligned with either one of two lateral supports 402.2 or 402.5 mounted on the train wagon 102 depending on which container is being discharged. The gripping device 470 as a gripping portion 472 which is again movable in at least two directions of movement which are substantially perpendicular to one another. In the embodiment illustrated in the accompanying drawings the two directions of movement again substantially vertically and horizontally. The gripping portion or claw 472 is carried on the end of a tubular body 474. The body 474 is mounted movably on a wheeled frame 476. The gripping device 470 further includes two actuators 478 and 480 forming the tubular body 474 and wheeled trolley 478 in the horizontal and vertical directions respectively. The actuators 478 and 480 are again in the form of double acting hydraulic piston and cylinder assemblies. The movement of the gripping portion 472 of the gripping device 470 is illustrated in Figure 36. From this figure it can be seen that extension and contraction of the hydraulic cylinder 478 causes the wheeled trolley 476 to move it downwardly and upwardly along to apart upright channel sections 482.1 and 482.2. In turn, extension and contraction of the hydraulic cylinder 480 causes the tubular body 474 to move back and forth along a substantially horizontal direction, i.e. towards and away from the container 302 mounted on the train wagon 102 in use.

During the discharge process the gripping portion 472 engages one of the lateral supports 402.2 or 402.5 mounted on the train wagon 102 on the side of the train wagon opposite the side from which the bulk material is being discharged. It must be understood that the gripping portion 47 holds onto

-43-

the train wagon 102 as a safety measure to prevent any accidental tipping of the train wagon during the container discharge process. It is believed that by gripping the train wagon 102 at a location substantially in the longitudinal centre of the container 302 the forces acting on the train wagon during discharge are more balanced.

The method of discharging the bulk material being transported in the containers 302 mounted on the rail wagon 102 using the tilting device 112 will now be described in greater detail with reference to Figures 37 and 38.

The train wagon 102 carrying two containers 302 in which the bulk material is being transported is moved into position next to the container tilting device 406. With or without stopping the wagon 102 the tilting apparatus 406 is moved into position alongside the wagon 102 and, accordingly the containers 302 mounted thereon. The container tilting apparatus 406 could be moved into position either manually or automatically through the use of sensors which detect the position of the containers. Next, the gripping portion 472 of the gripping device 470 is moved to the height of the lateral support 402.2 mounted on the train wagon 102. The gripping portion 472 is then moved towards to train wagon 102 until it engages the lateral support 402.2. With the gripping device 470 engaging the train wagon 102 the coupling mechanisms 410 may engage the door mechanisms 322 on the container 302. Before the container 302 can be tilted it is necessary to disengage the lock which prevents the drive link 332 of the door mechanism from moving when locked. In order to unlock the lock on the drive link 332 the hook 416 must be moved along a path 488 shown in Figure 38(a) to (c). First, the hook 416 must be lowered by lowering the vertical slide 416 so that the catch 448 engages the bar 414. Next, the hydraulic cylinder 454 is contracted to move the hook 416 towards the container 302 until the hook is position below the bar 336 carried by the drive link 332. With the hook 416 in the position illustrated in Figure 38(b) the hydraulic cylinders 432 are extended so as to move the vertical slide 412 upwardly, thereby lifting the hook 416 to engage the bar 336. Figure 38(c) shows the position of the hook 416 in which it engages the bar 336

-44-

carried on the drive link 332 of the door mechanism 332. When the hook 416 engages the bar 336 the actuator 454 is extended to pull the drive link 332 and bar 336 in the direction away from the container 302 indicated by the numeral 484 in Figure 38(c). As described above with reference to the sub-system 300, movement of the drive link 332 in the direction 484 (which is the same as the direction 350) opens the container door 18 to discharge the bulk material. In order to empty the container 302 completely it is required to lift it so as to tilt the container about the pivot connectors 310 located in the sockets 312 or the upstanding frames 314 mounted on the train wagon 102. The container 302 is lifted by extending the hydraulic cylinders 432, thereby lifting the vertical slide 412 and the bar 414 carried by it. Different stages of extension of the hydraulic cylinders 432 are shown in Figures 38(d) to (f), which also show the arcuate path along which the hook 416 travels during the discharge of the container 302. From Figures 38(d) to (f) it can be seen that the mounting arrangement between the bar 414 and vertical slide 412 allows the bar to slide substantially horizontally towards the container 302 while it is being lifted by the vertical slide 412, thereby allowing the hook 416 to travel along its arcuate path during the discharge of the container. Similarly to the first embodiment of the sub-system bar 414 is disengaged from the catch 448 during arcuate movement of the hook 416.

It must be understood that the hook 416 returns to its position as shown in Figure 38(d) once the container 302 has been discharged and the vertical slide is lowered through contraction of the hydraulic cylinders 432. It must further be understood that the above process is repeated in reverse to close the container door 18 and lock the drive link 332 into its locked position before the container 302 is transported away from the discharge site. As the vertical slide 412 is lowered, the bar 414 again engages the catch 448 of the actuating mechanism 446. Thereafter, the hydraulic cylinder 454 is contracted to cause the catch to move towards the container 302, thereby moving the drive link 332 back towards the container. This causes the door mechanism 322 to close the container door 18. The door is

again automatically locked as the door mechanism includes rear locking means 500 to lock the drive link 332.

The rear locking means 500 of this embodiment is illustrated in Figure 39 and Figure 40. Different stages of the process of unlocking the rear locking means 500 by using the door actuating mechanism 338 of the trailer 16 are shown in Figure 39. Figure 40 in turn illustrates different stages of the process of unlocking the rear locking means 500 by using the container tilting device 406 of the sub-system 400.

The rear locking means 500 is located on the drive link 52 in a position which is in use at the rear of the container, i.e. at the sidewall 20.2. The locking means 500 includes a locking formation 502 which is movable into and out of a recess 504. When located in the recess 504 for the locking formation 502 is held captive therein by a retaining formation or lip five or six. From figures 39 and 46 must be clear that the retaining formation 502 locks the drive link 332 and accordingly the door mechanism 322 in a position wherein the door 18 is closed. The locking formation is therefore movable between a lock position wherein it is held captive in the recess 504 and a release position wherein it is released from the recess 504 so that the drive link 52 could be moved. In the illustrated embodiment of figures 39 and 40 the locking formation 502 is biased towards its locked position by means of a spring 508. In use, the spring act on a base of the locking formation 52 so as to urge it into its locked position. To move the locking formation 52 from its locked position to its release position against its spring bias the locking means includes two compression members 410 and 412 which are movable independently from one another in order to compress the spring 508. The compression member 410 carries an arm 414 projecting therefrom for engaging the hook 416 of the container tilting device 406. The compression member 512 and its arm 514 are arranged such that engagement with the hook 416 of the container tilting device 406 causes the member 510 to pivot about a pin 516 to move the locking formation 502 from its locked position to its release position. The compression member 512 on the other hand is connected to the

-46-

engagement formation 324 by a connector in the form of a rod 518. The compression member 514 and the corresponding rod 518 are in turn arranged such that movement of the engaging formation 324 in the direction 352 causes the member 512 to pivot about a pin 520 to move the locking formation 502 from its locked position to its release position.

From the above description of the locking means 500 it should be clear that, in use, it can be unlocked in order to allow the door mechanism 322 to open the container door 18 by either using the container tilting device 464 the door actuating mechanism 338.

Once the container door 18 is locked in its closed position the actuators 432 are contracted further to disengage the hook 416 from the bar 336 on the drive link 332. Next, the actuator 454 is extended to move the catch 448 away from the container 302, thereby allowing free movement between the container tilting device 406 and the container 302.

With the coupling mechanism 410 in their positions illustrated in Figure 38(a), the container tilting device 406 is free to move to the second container mounted on the rail wagon 102 and the above method of discharging the bulk material is repeated.

Similarly to the first embodiment of the sub-system 100 it is again believed that more than one container tilting device 406 could be used in series on the same set of rails 116 so that multiple containers 302 can be discharge simultaneously. The container tilting device 406 could even be fixed to one another so that they move in harmony in order to discharge the containers 302 simultaneously.

From the above description it should be clear that the same advantages described above with reference to the use of the sub-system 300 are achieved when using the sub-system 400. The description of the position of the centre of gravity during the course of the discharge process with

reference to the sub-system 300 applies to the discharge process of sub-system 400.

It must be again be understood the both sub-systems 300 and 400 form part of the holistic bulk material handling system. The same advantages of interchangeability and adaptability between different modes of transport are achieved using the system in accordance with the second embodiment of the invention. It is envisaged that, should it be required to switch between different modes of transport, the containers 302 can simply be dismounted from one type of carriage, for example the trailer 16, and mounted on another type of carriage, for example the rail wagon 102, while fully loaded with bulk material. It is envisaged that the containers could be moved by using lifting machines such as cranes, forklifts and reach stackers, for example. By way of example, the containers 302 could be lifted by connecting a reach stacker to connections 360 in the top corner regions of the container 302 or by inserting the tines or forks of a forklift into the space between the bottom of the container and trailer or wagon created by the corner castings 308.

Irrespective of the mode of transport the containers 302 can easily be discharged as they allow for two different methods of actuating the door mechanisms 322 as described above. When using either method of discharging the container there is no need to remove a loaded container from either the carriage on which it is carried.

However, it must be noted that when the container is being transported on the trailer 16, the door 18 will be retained in its closed position by the door actuating mechanism 338 engaging the drive link 332. The locking means, which is used to lock the drive link 332 and thus the door 18 when the container 302 is being transported by rail, can therefore be bypassed when the container 302 is being transported by road. In fact, to allow the door actuating mechanism 338 to move the drive link 332 to open the door 18 the locking means must first be disengaged. It is therefore envisaged that an upstanding formation or projection 486 (Figure 27) could be carried on

-48-

the trailer 16 to lift the drive link in order to disengage the lock when the container 302 is mounted on the trailer. The projection 486 will automatically unlock the lock on the drive link 332 so that the door actuating mechanism could open the door 18.

Although not illustrated in the accompanying drawings, there is also provided for the container tilting device 406 to include an arm extending laterally towards the train wagon and into the path of travel of the train wagon. As the train wagon approaches the position of the container tilting device 406 the leading end of the container 302 or train wagon 102 will make contact with the arm so as to drag the container tilting apparatus with the train wagon, thereby automatically positioning the container tilting device with respect to the container and causing the container tilting device to be moved at the same speed as the train wagon. It is envisaged that irrespective of the manner in which the container tilting device engages the train wagon or container it could include damping means to soften the impact when the tilting device engages the train wagon or container. There is also provided for the container tilting device to include its own propulsion and braking systems.

**CLAIMS**

1. A side discharge container for transporting bulk material, the container including:
  - at least one door through which the bulk material can be discharged; and
  - a door mechanism which is operable between a first, locked position wherein the container door is locked in its closed position and a second, unlocked position wherein the container door is open to discharge the bulk material, wherein the door mechanism includes a series of links which are movably connected to one another, wherein at least one of the links carries an engagement formation for engaging a door actuating mechanism, and wherein at least one of the links carries another engagement formation for engaging a container tilting device, such that the door mechanism is operable by using either the door actuating mechanism or the container tilting device.
2. A container according to claim 1, wherein the series of links includes an actuating link which is connected pivotally to the container body, and a connecting link which connects the actuating link to a drive link, wherein the engagement formation for engaging the door actuating mechanism is carried by the drive link such that movement of the drive link causes the actuating link to pivot relative to the container body in order to open and close the container door.
3. A container according to claim 2, wherein the engagement formation for engaging the container tilting device is also carried by the drive link such that the drive link is movable through either engagement with the door actuating mechanism or container tilting device in order cause the actuating link to pivot relative to the container body in order to open and close the container door.

-50-

4. A container according to claim 2, wherein the series of links includes a second actuating link pivotally connected to the container, wherein the engagement formation for engaging the container tilting device is located on the second actuating link.
5. A container according to any one of claims 2 to 4, wherein the connecting link comprises a pre-tensioning device for adjusting the force acting to keep the door in its closed position.
6. A container according to any one of claims 2 to 5, wherein the door mechanism includes locking means which automatically locks the door in its closed position when the door mechanism is moved into its locked position.
7. A container according to claim 6, wherein the connecting link is carried on a slide which moves on a support surface defining a nock, and wherein the slide is moved passed the nock when moving the door mechanism into its closed position, thereby automatically locking the connecting link in an over-centre position in order to lock the container door in its locked position.
8. A container according to either claim 6 or 7, wherein the container includes second locking means which automatically locks the door in its closed position when the door mechanism is moved into its locked position.
9. A container according to claim 8, wherein the second locking means is in the form of complementally shaped locking formations located on one of the links of the door mechanism and the container, the locking formations being arranged so as to engage one another when the door mechanism is in its closed position, such that, in use, the link carrying the locking formation must first be lifted to disengage the locking formations from one another to allow the door mechanism to be moved into its open position.

-51-

10. A container according to any one of claims 1 to 9, including a sloped floor which at least in part slopes generally upward towards the sidewall in which the container door is located.
11. A container according to claim 10, wherein the door mechanism is at least partially located in a cavity provided between the sloped container floor and the bottom of the container.
12. A container according to either claim 10 or 11, wherein the container door is hinged to a raised portion of the sloped floor so as to raise the hinge point about which the door hinges when moving between its open and closed positions.
13. A container according to any one of claims 1 to 12, including pivot connectors for engaging complementally shaped pivot connectors provided on a carriage on which the container is, in use, transported, wherein the pivot connectors on the container are located on support structures located inside the container, and wherein the container includes cavities in which the pivot connectors on the carriage is in used received when the container is located on the carriage.
14. A container according to claim 13, wherein the cavities in which the pivot connectors of the carriage are received are open to the bottom of the container so that the pivot connectors of the carriage are received through the floor of the container when the container is lowered onto the carriage.
15. Method of discharging a side discharge container carried, in use, on a carriage, the method including the steps of:
  - engaging a door mechanism which is operable between a first, locked position wherein a container door is locked in its closed position and a second, unlocked position wherein the container door is open to discharge the bulk material;
  - disengaging a locking device to allow movement of the door mechanism from its locked position into its unlocked position;

-52-

moving a linkage of the door mechanism to move the door mechanism from its locked position into its unlocked position, thereby opening the door of the container to start discharging the bulk material from the container;

pivoting the container about a pivot axis running substantially parallel to the longitudinal length of the container from a transport position to a discharge position;

pivoting the container back into its transport position;

closing the container door by moving the linkage of the door mechanism to move the door mechanism from its unlocked position into its locked position; and

automatically locking the door in its closed position by moving the door mechanism back into its locked position.

16. A method according to claim 15, wherein the step of engaging the door mechanism includes engaging an engagement formation carried by a door actuation mechanism with a complementally shaped engagement formation carried on the linkage of the door mechanism.
17. A method according to claim 16, wherein the step of moving the door mechanism from its locked position into its unlocked position includes moving engagement means carrying the engagement formation of the door actuation mechanism in a first direction of movement through actuation of a first actuator.
18. A method according to claim 17, wherein the step of pivoting the container from its transport position to its discharge position includes first moving the engagement means carrying the engagement formation of the door actuation mechanism in a second direction of movement, which is substantially opposite the first direction of movement, through actuation of a second actuator in order to allow the engagement formation of the door actuating mechanism to be released from the engagement means.

19. A method according to claim 17, wherein the step of pivoting the container from its transport position to its discharge position includes actuating the first actuator.
20. A method according to either claim 18 or 19, including operating both actuators simultaneously for controlled movement of the container door when opening the door while the container is carrying bulk material, thereby preventing the container door from collapsing from its closed position into its open position under the weight of the bulk material.
21. A method according to any one of claims 15 to 20, wherein the locking device is automatically unlocked when the container is loaded onto the carriage.
22. A method according to any one of claims 15 to 21, wherein the container door is automatically locked by over-centring a connecting link of the door mechanism.
23. A method according to claim 15, wherein the step of engaging the door mechanism includes engaging an engagement formation carried by a container tilting device with a complementally shaped engagement formation carried on the linkage of the door mechanism.
24. A method according to claim 23, wherein the step of disengaging the locking device includes lifting the linkage of the door mechanism to remove a locking formation from a recess formed on the linkage.
25. A container tilting device for discharging a container carried on a carriage, the device including:
  - a coupling mechanism having a bar carrying a coupler for coupling to the container and a movable slide which, in use, carries the bar along a first axis of movement, the bar being movable with respect to the slide along a second axis of movement;

-54-

an actuating mechanism carrying engaging means for engaging complementally shaped engaging means of the bar so that when the complementally engaging means are engaged the bar may be moved back and forth along the second axis of movement through actuation of the actuating mechanism to move the coupler carried by the bar to and from the container; and

a lifting system to move the slide carrying the bar along the first axis of movement;

such that, in use, the first axis of movement is substantially vertical so that the coupler is lifted when the slide is moved upwardly by the lifting system in order to tilt the container when the coupler is connected thereto, thereby causing the bulk material to be discharged from the container.

26. A container tilting device according to claim 25, wherein the engaging means of the actuating mechanism is in the form of an open recess defined in a movable catch such that the engaging means carried by the bar is automatically released from the recess through the upward movement of the slide so as to allow the bar to move freely along the second axis of movement while being lifted by the slide, thereby allowing the coupler to travel along an arcuate path during tilting of the container from its transport position into its discharge position.
27. A container tilting device according to claim 26, wherein the actuating mechanism includes a first actuator for moving the catch along the second axis of movement.
28. A container tilting device according to claim 25, wherein the first actuator is in the form of a double acting hydraulic piston and cylinder assembly.
29. A container tilting device according to any one of claims 25 to 28, wherein the lifting system includes a trolley which is movably mounted inside a frame structure in a manner allowing the trolley to

-55-

be movable along the first axis of movement, the slide being movably mounted inside the trolley, and wherein the lifting mechanism includes at least one actuator for moving the trolley along the first axis of movement.

30. A container tilting device according to claim 29, wherein the lifting system includes a series of pulleys carried by the trolley and a flexible drive means running from the slide, over the pulleys and back to the slide such that so as to cause the vertical slide to move when the trolley is moved through actuation of the actuator driving the trolley.
31. A container tilting device according to claim 30, wherein the flexible drive means is a chain and the pulleys are sprockets.
32. A container tilting device according to claim 31, wherein the lifting system includes two separate chains, each having their corresponding series of sprockets so as to balance the forces acting on the trolley and slide during actuation of the actuator driving the trolley.
33. A container tilting device according to any one of claims 29 to 32, wherein the actuator driving the trolley is a double acting hydraulic piston and cylinder assembly.
34. A container tilting device according to any one of claim 25 to 33, includes two coupling mechanisms for coupling to the container at two position, wherein each coupling mechanism has its own actuating mechanism and lifting system.
35. A container tilting device according to claim 34, wherein the movement of the coupling mechanisms are synchronised.
36. A container tilting device according to any one of claims 25 to 35, including a gripping device for gripping onto the carriage during discharging of the container, thereby acting as a safety mechanism to prevent any accidental flipping of carriage.

37. A container tilting device according to claim 36, wherein a gripping portion which, in use, grips onto the carriage is movable along both the first and second axes of movement, thereby allowing the gripping portion to be movable toward and away from the carriage on which the container is being carried and to compensate for a height differential between different carriages.
38. A container tilting device according to any one of claims 25 to 37, including a wheeled base thereby allowing the device to be movable between different containers without having to move the carriage.
39. A container tilting device according to claim 38, including a propulsion system and braking system.
40. A container tilting device according to claim 39, including sensors for automatically aligned the container tilting device with the container carried on the carriage.
41. A method of discharging a container being carried on a carriage using a container tilting device according, the method including the following steps:
  - moving the container tilting device alongside the container;
  - moving a coupler for coupling to the container in a direction towards the container;
  - lifting the coupler to engage it with a corresponding engagement formation located on a door mechanism of the container;
  - moving the coupler in a direction away from the container in order to actuate the door mechanism to open a side discharge door in the container;
  - lifting the coupler to tilt the container from its transport position into its discharge position;
  - lowering the coupler after discharge of the bulk material so that the container is moved back into its transport position;

-57-

moving the coupler in a direction towards the container in order to close the container door; and

lowering the coupler further to disengage the door mechanism of the container.

42. A method according to claim 41, wherein the step of moving the container tilting device alongside the container includes automatically aligning the coupler with the door mechanism on the container by using sensors to detect the position of the container.
43. A method according to claim 41, wherein the step of moving the container tilting device alongside the container includes automatically aligning the coupler with the door mechanism on the container by extending a latching arm mounted on the container tilting device into the travel path of the carriage.
44. A method according to any one of claims 41 to 43, including disengaging locking means acting between the door mechanism and container before moving the coupler in a direction away from the container to actuate the door mechanism.
45. A method according to claim 44, wherein the step of disengaging the locking means includes lifting the coupler after it is engaged with the corresponding engagement formation located on the door mechanism, thereby to remove a locking formation of the locking means from a recess in which the locking formation is received when the locking means is engaged.
46. A method according to either claim 44 and 45, including automatically engaging the locking means when closing the container door and disengaging the door mechanism.
47. A method according to any one of claims 41 to 46, wherein the step of lifting the coupler to tilt the container from its transport position into

-58-

its discharge position includes allowing the coupler to move freely along an arcuate path.

48. A method according to any one of claims 41 to 47, including the step of providing a pulley system to achieve a gain in travel distance of the coupler relative to the travel distance of an actuator used in lifting the coupler of at least two.
49. A method according to claim 48, including the use of two separate flexible drive means each having its corresponding series of pulleys so as to balance the forces acting on coupler during the tilting of the container.
50. A method according to any one of claims 41 to 49, including the use of double acting hydraulic piston and cylinder assemblies to move the coupler.
51. A method according to any one of claims 41 to 50, including providing two couplers for coupling to the container at two positions.
52. A method according to claim 51, wherein the movement of the two couplers are synchronised.
53. A method according to any one of claims 41 to 52, including gripping onto the carriage during discharging of the container, thereby providing a safety mechanism to prevent any accidental flipping of the carriage.
54. A method according to any one of claims 41 to 53, including mounting the container tilting device on a wheeled base thereby allowing the device to be movable between different containers without having to move the carriage.

-59-

55. A method according to claim 54, including moving the container tilting device between different container or carriages by using a propulsion system and braking system of the container tilting device.
56. A method according to any one of claims 41 to 55, wherein the discharge process is carried out while the carriage and the container mounted thereon are in motion.
57. A container handling system for discharging bulk material, the system including:
- a side discharge container including:
    - at least one door through which the bulk material can be discharged;
    - a door mechanism which is operable between a first, locked position wherein the container door is locked in its closed position and a second, unlocked position wherein the container door is open to discharge the bulk material; and
    - pivot connectors located on support structures located inside the container;
  - a carriage on which the container is in use mounted, the carriage carrying pivot connectors for engagement with the complementally shaped pivot connectors on the container so that the container may be pivoted, about a pivot axis running substantially along the longitudinal length of the carriage; and
  - a container tilting device for engaging the door mechanism and tilting the container while the container is mounted on the carriage;
    - such that the container may be tilted in order to discharge the bulk material by either using an actuating mechanism carried by the carriage or using the container tilting device.
58. A container handling system according to claim 57, wherein the container is a container in accordance with any one of claims 1 to 14.

-60-

59. A container handling system according to either claims 57 or 58, wherein the container tilting device is a device in accordance with any one of claims 25 to 40.
60. A container handling system according to any one of claims 57 to 59, wherein the carriage is either a truck drawn trailer or a train wagon.



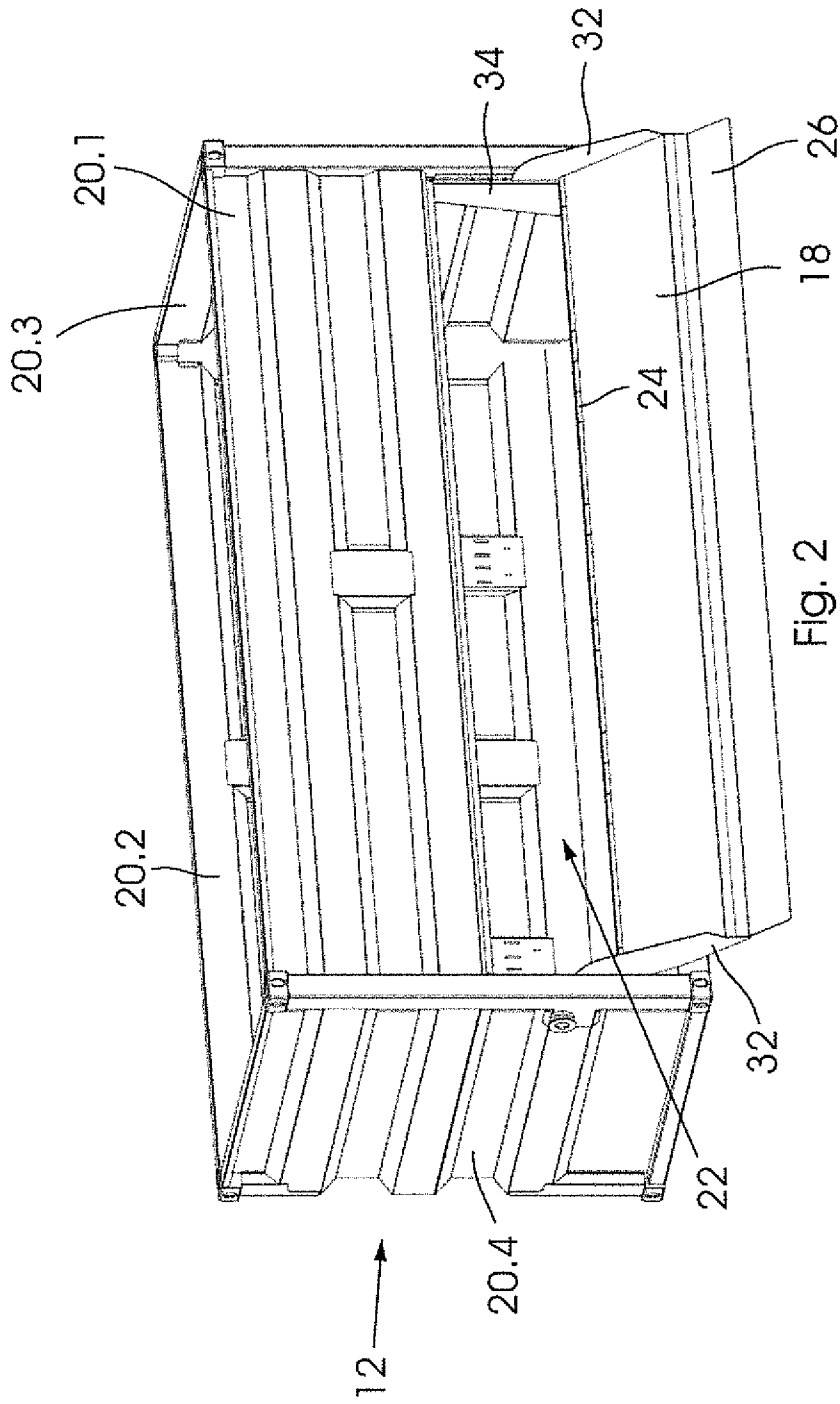

Fig. 2

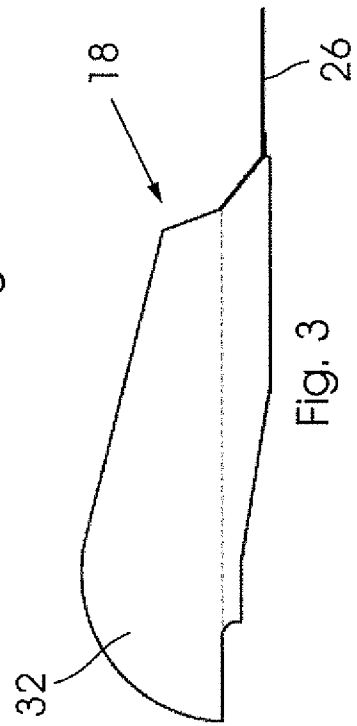

Fig. 3

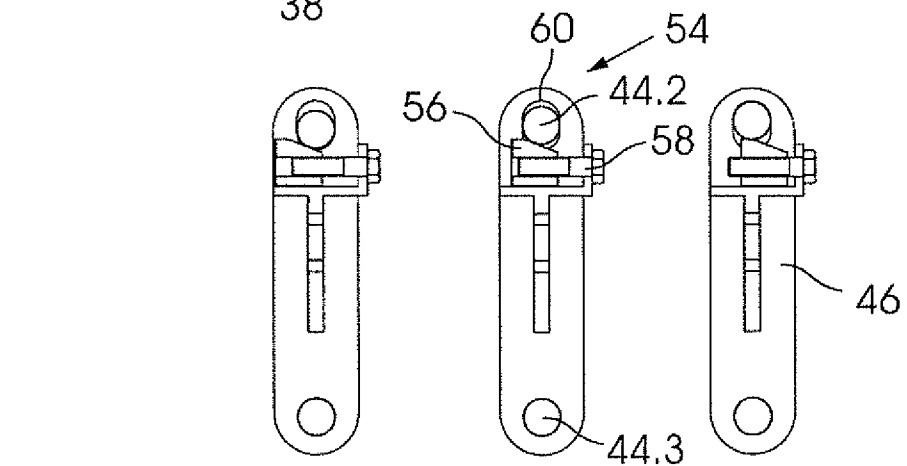
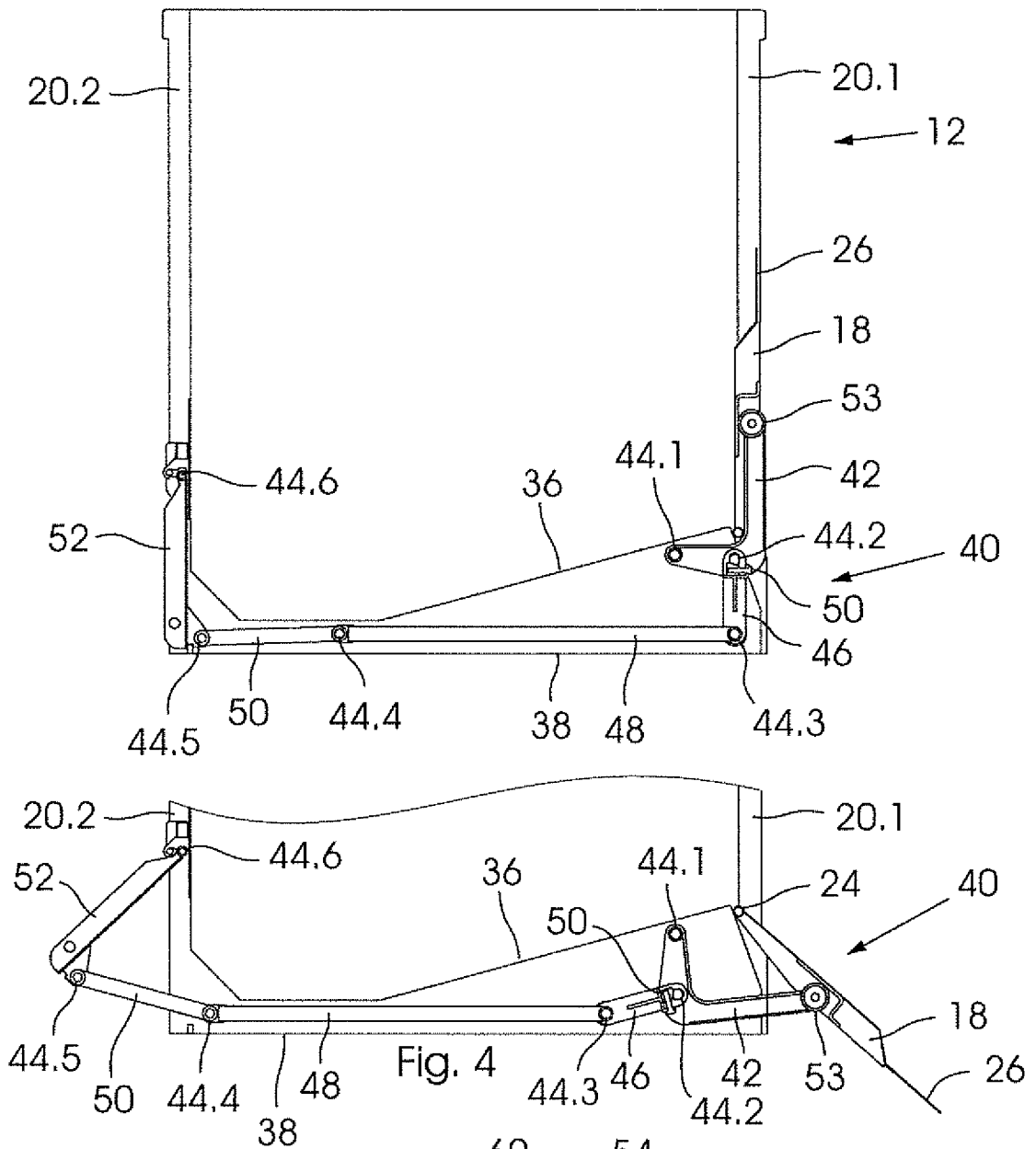

Fig. 5

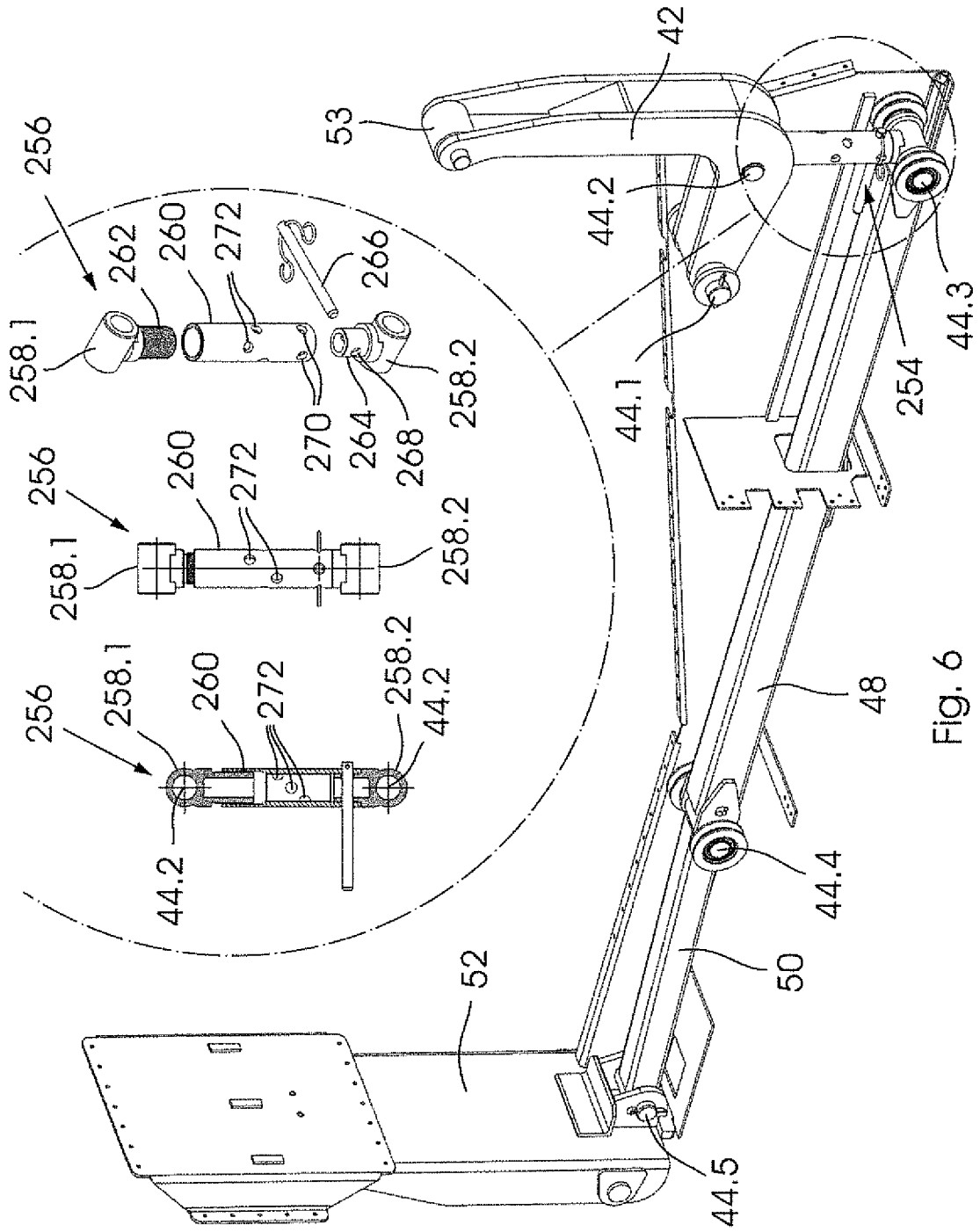

Fig. 6

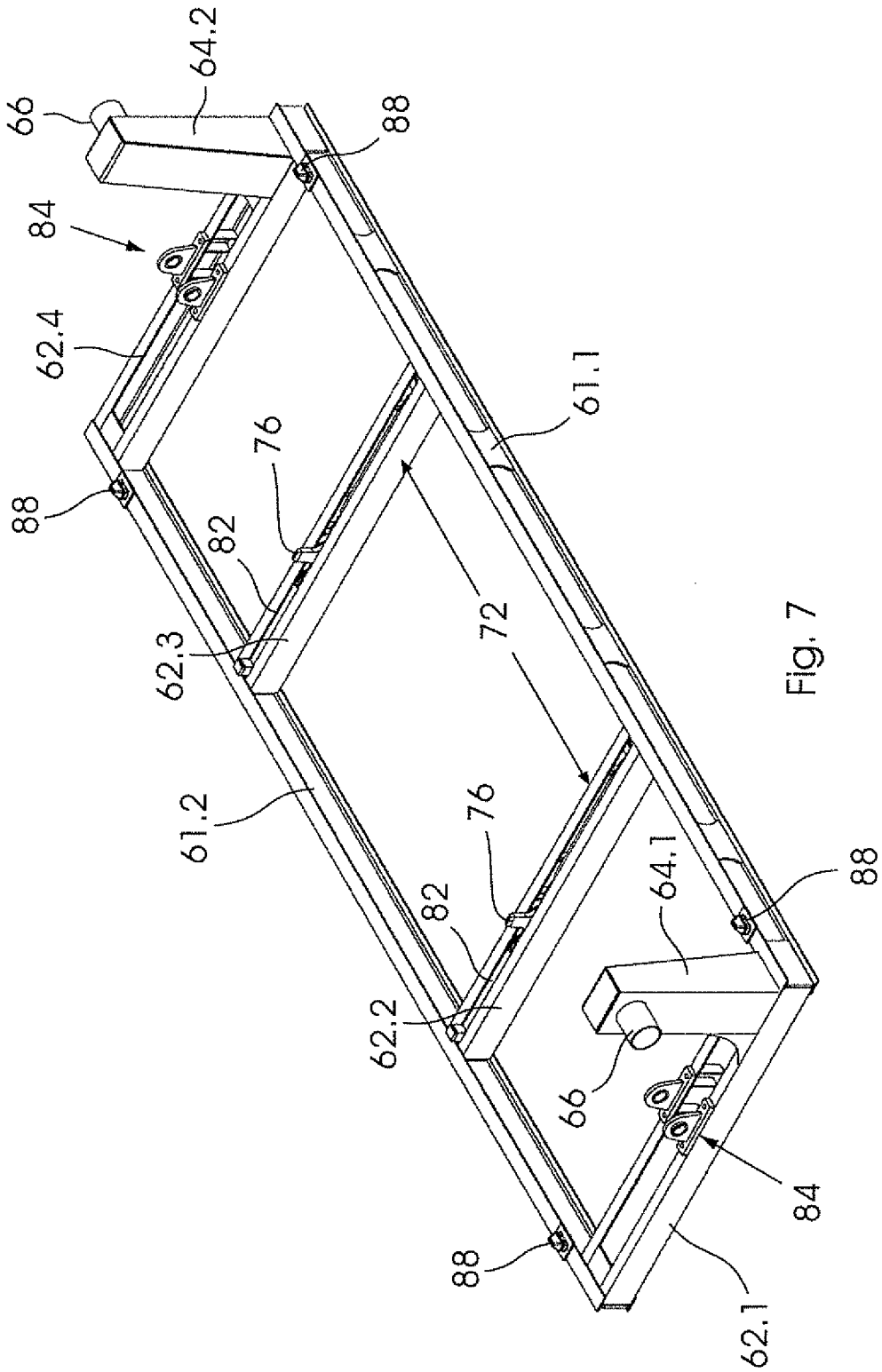

FIG. 7

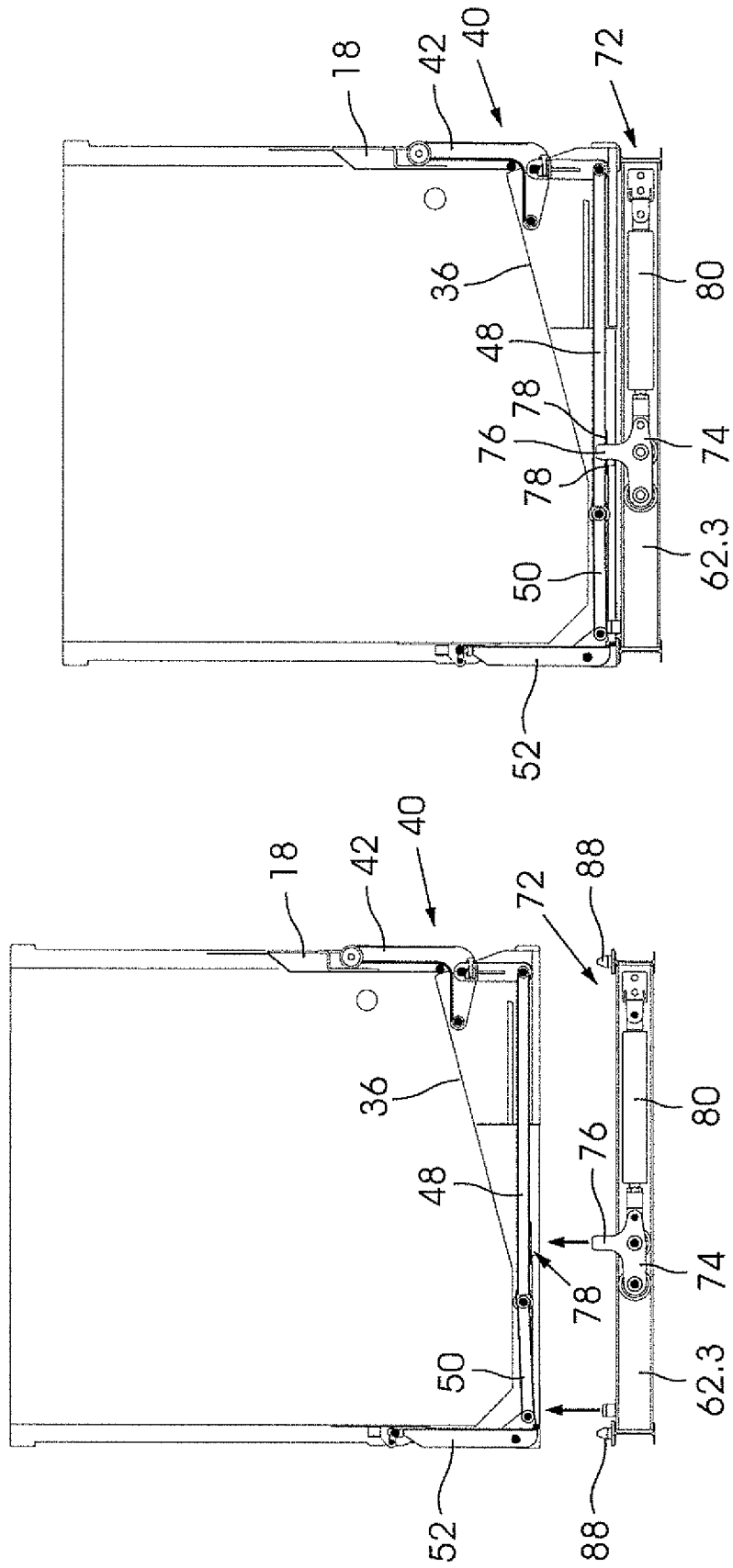

Fig. 8

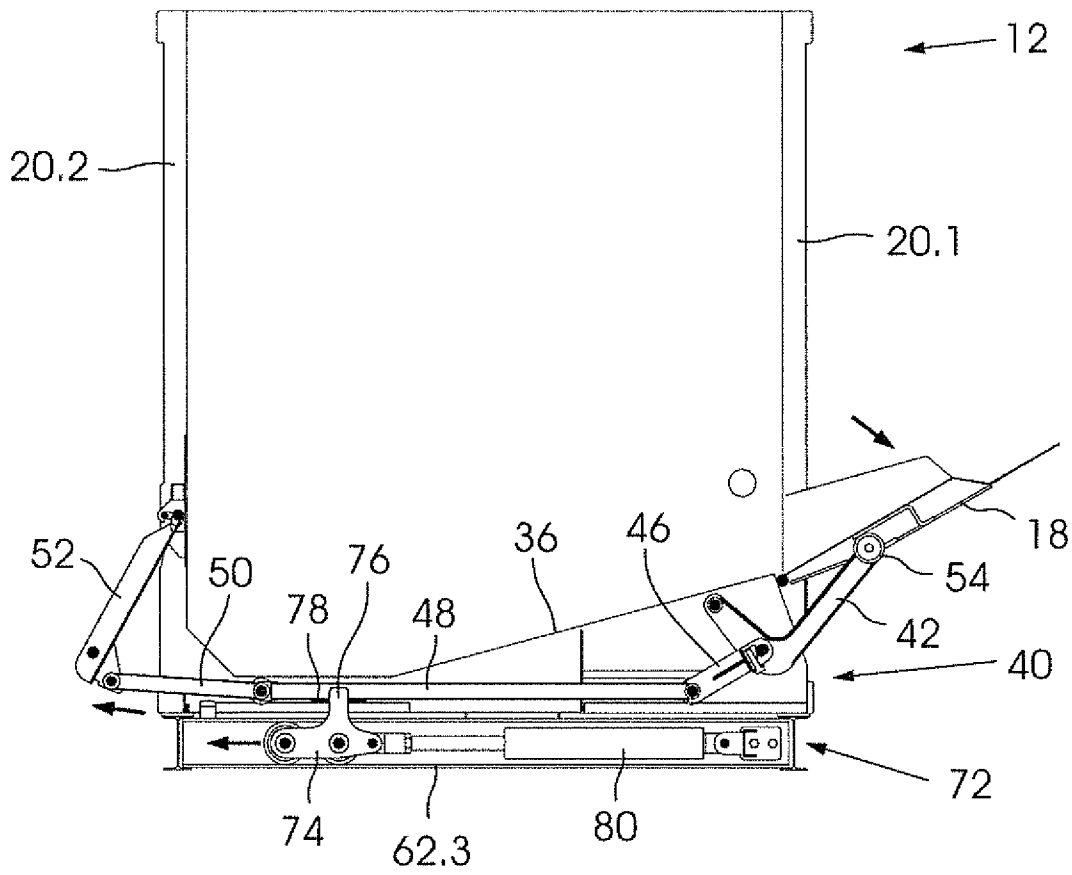

Fig. 9

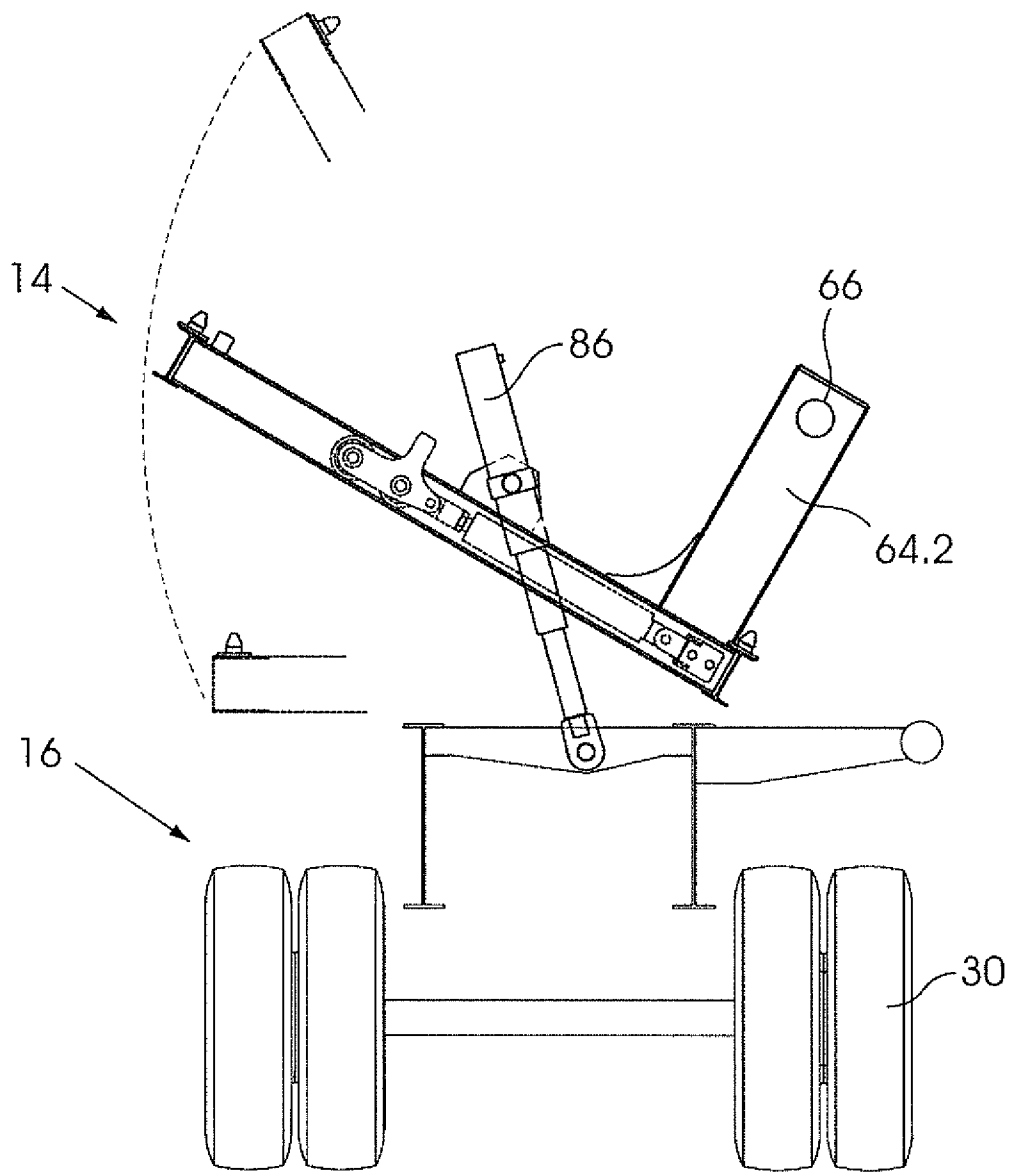

Fig. 10

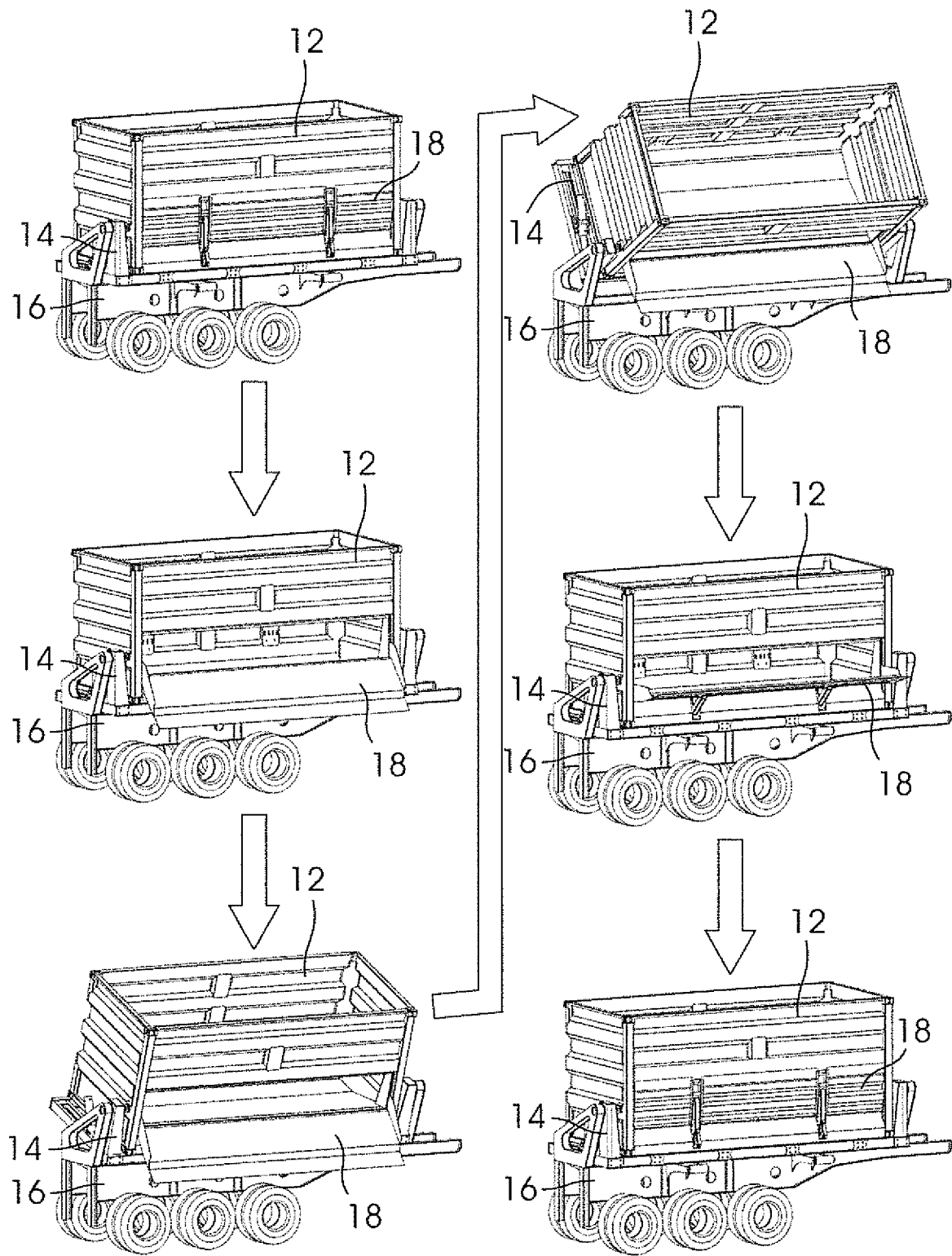

Fig. 11

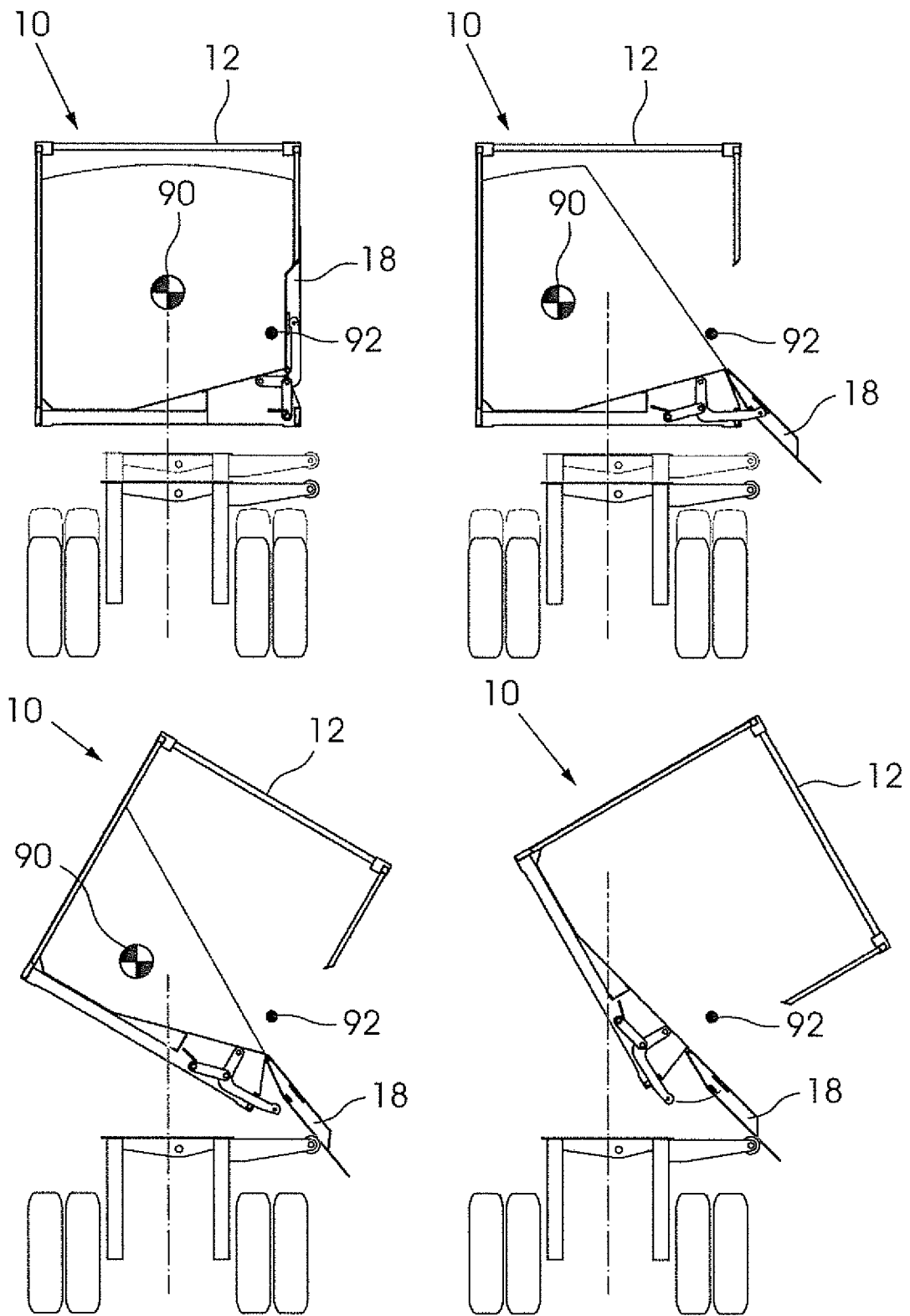

Fig. 12

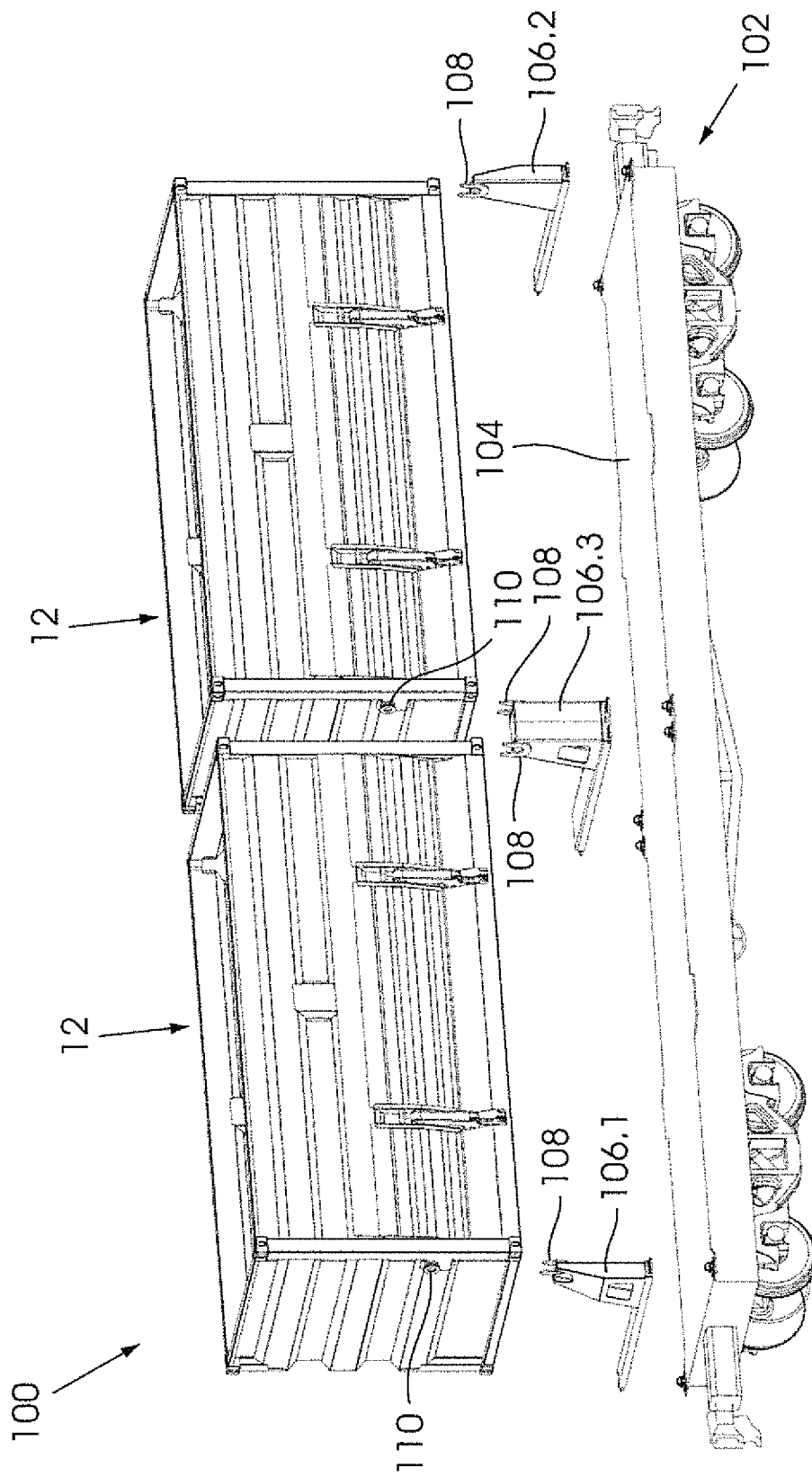
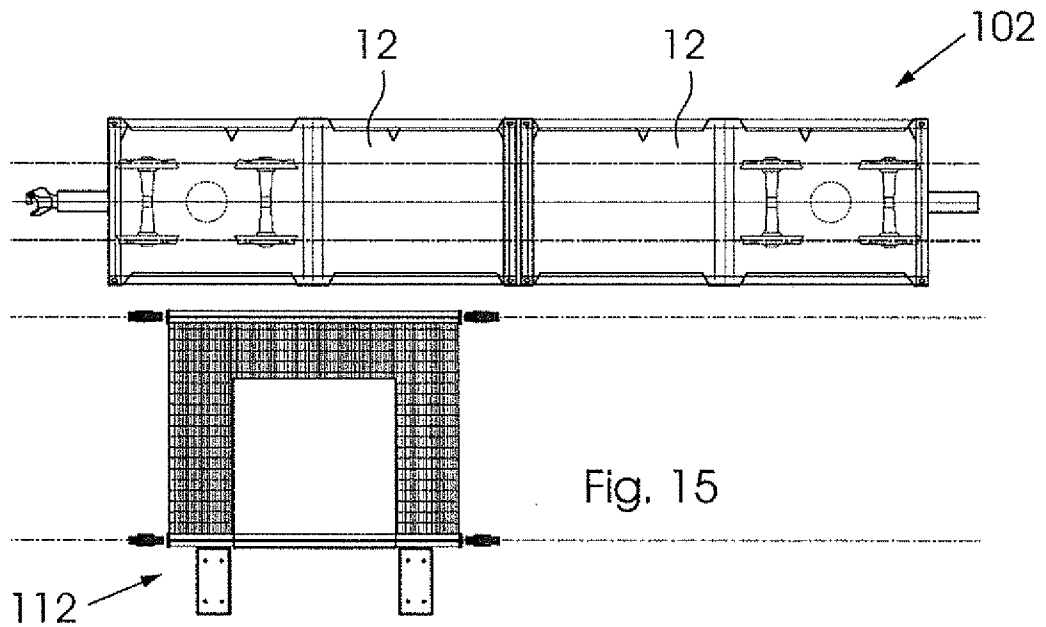
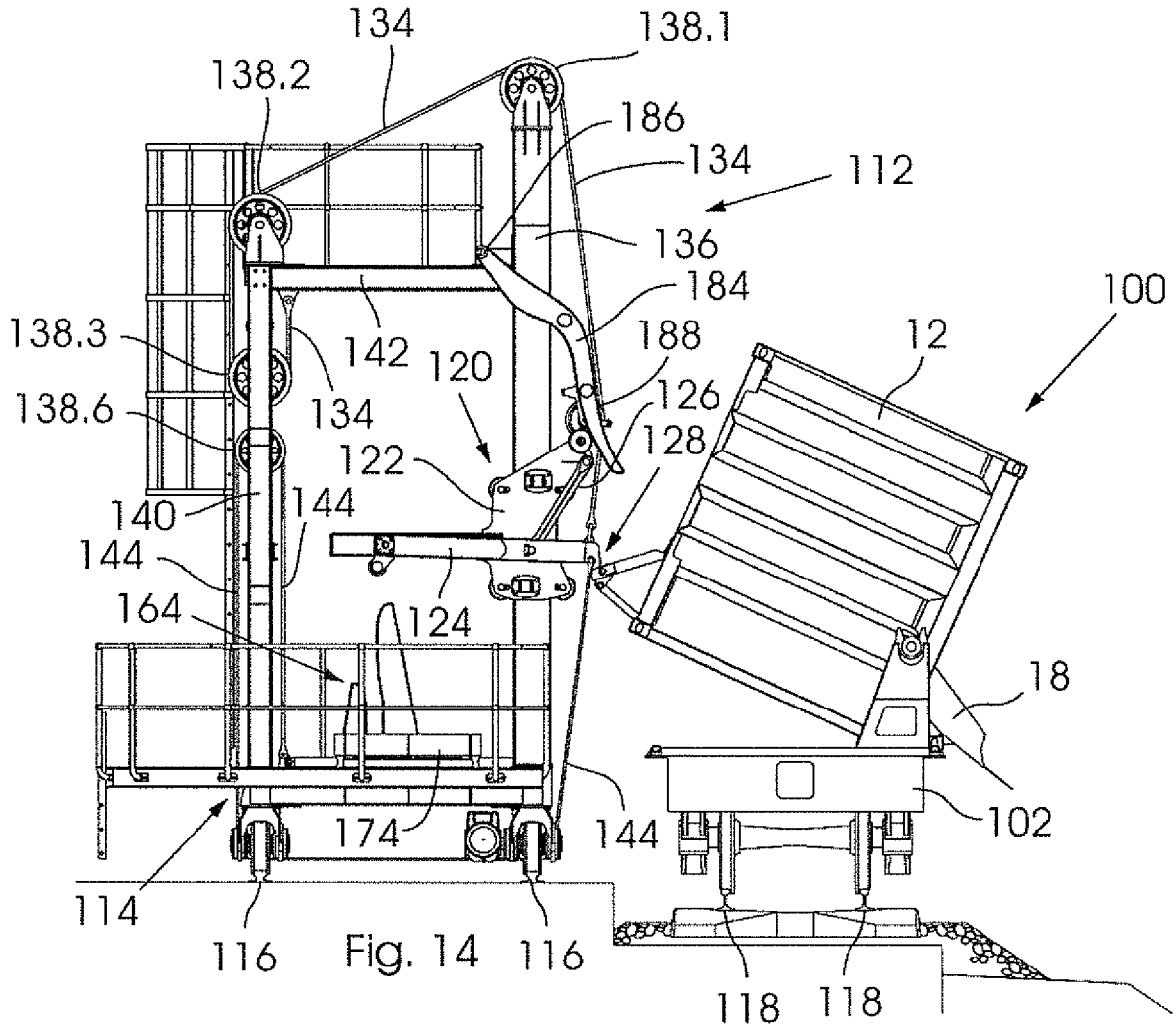

Fig. 13



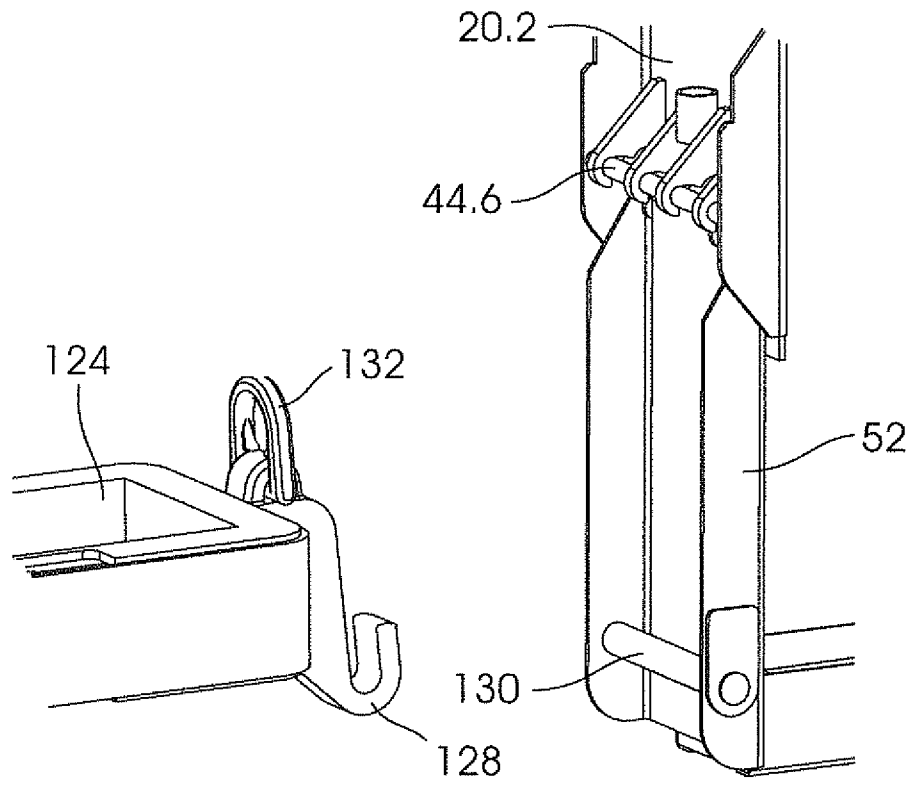

Fig. 16

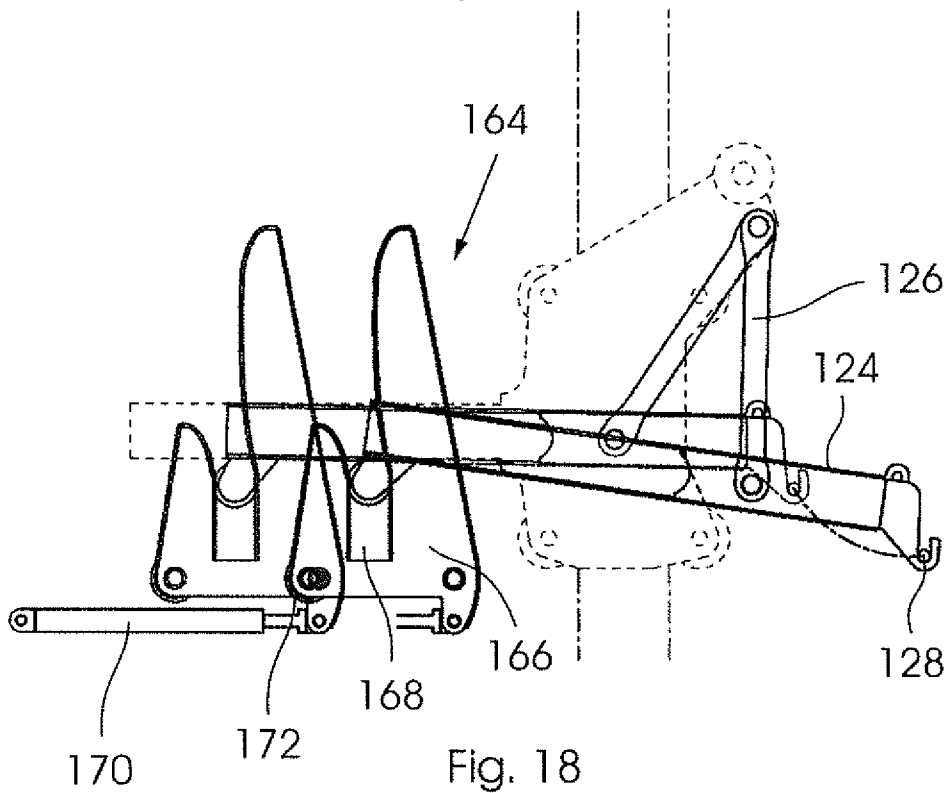

Fig. 18

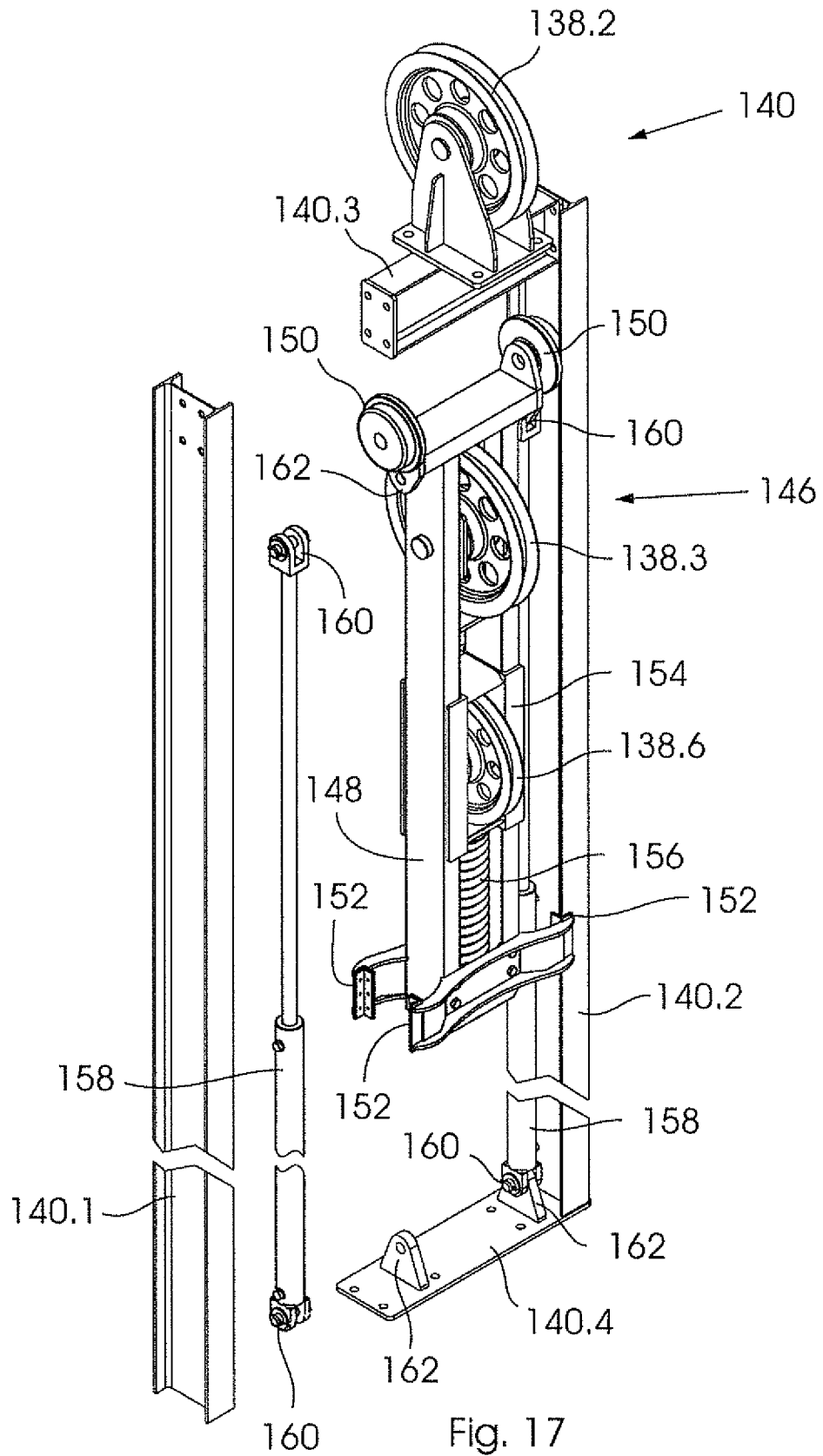

Fig. 17

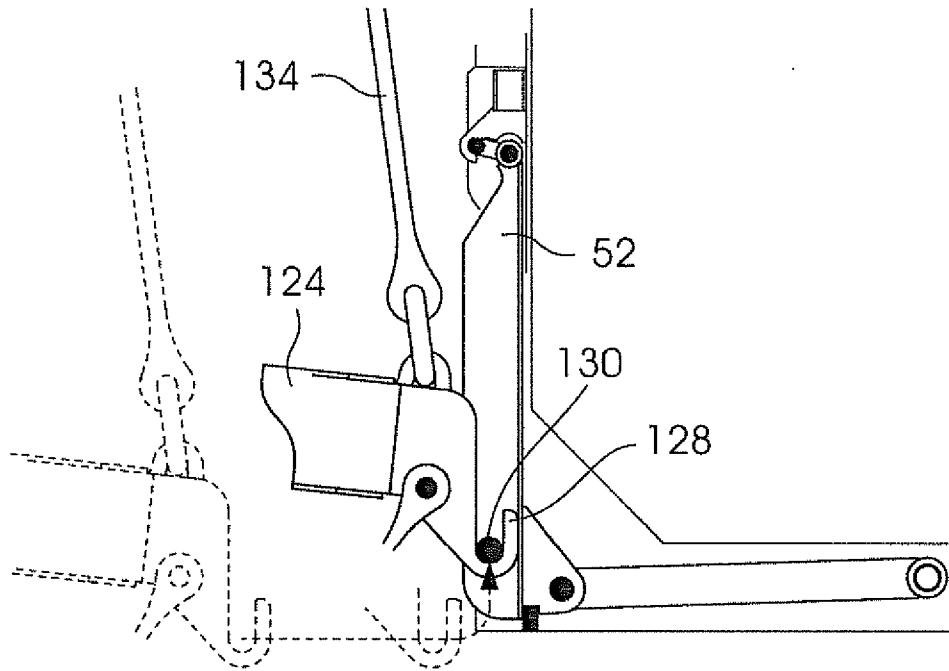

Fig. 19

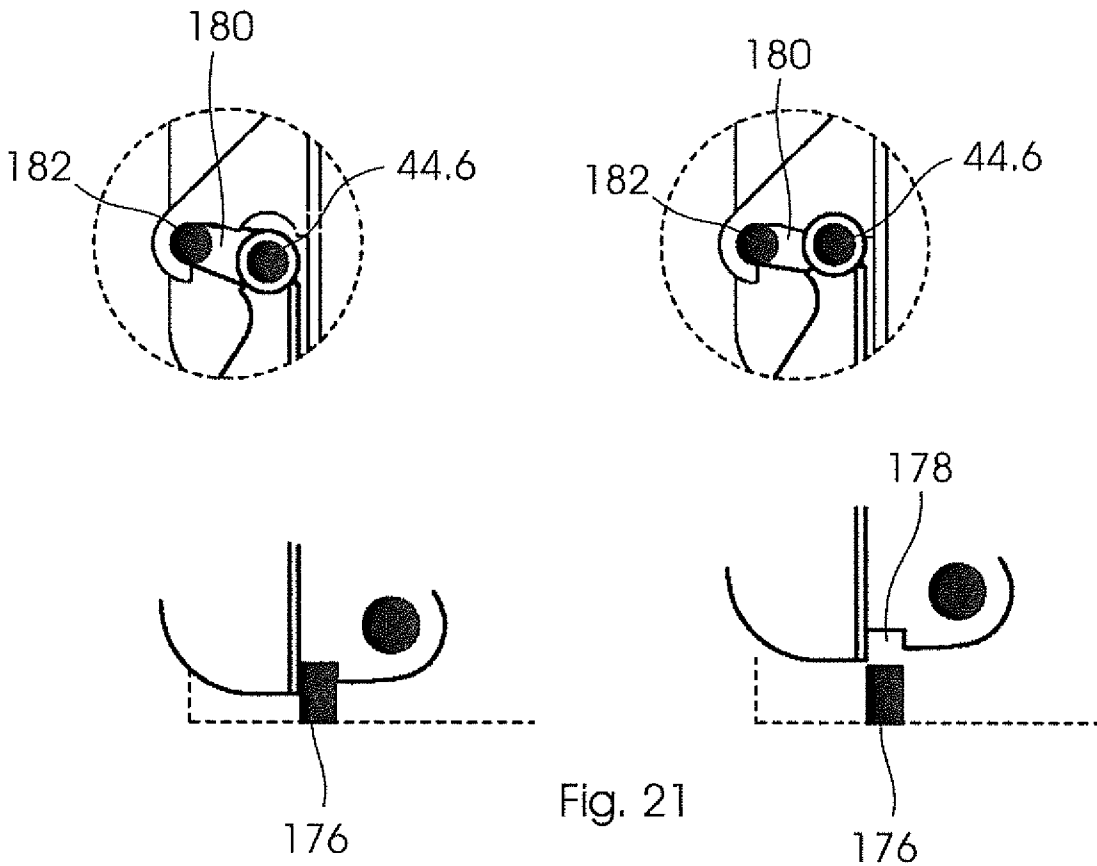
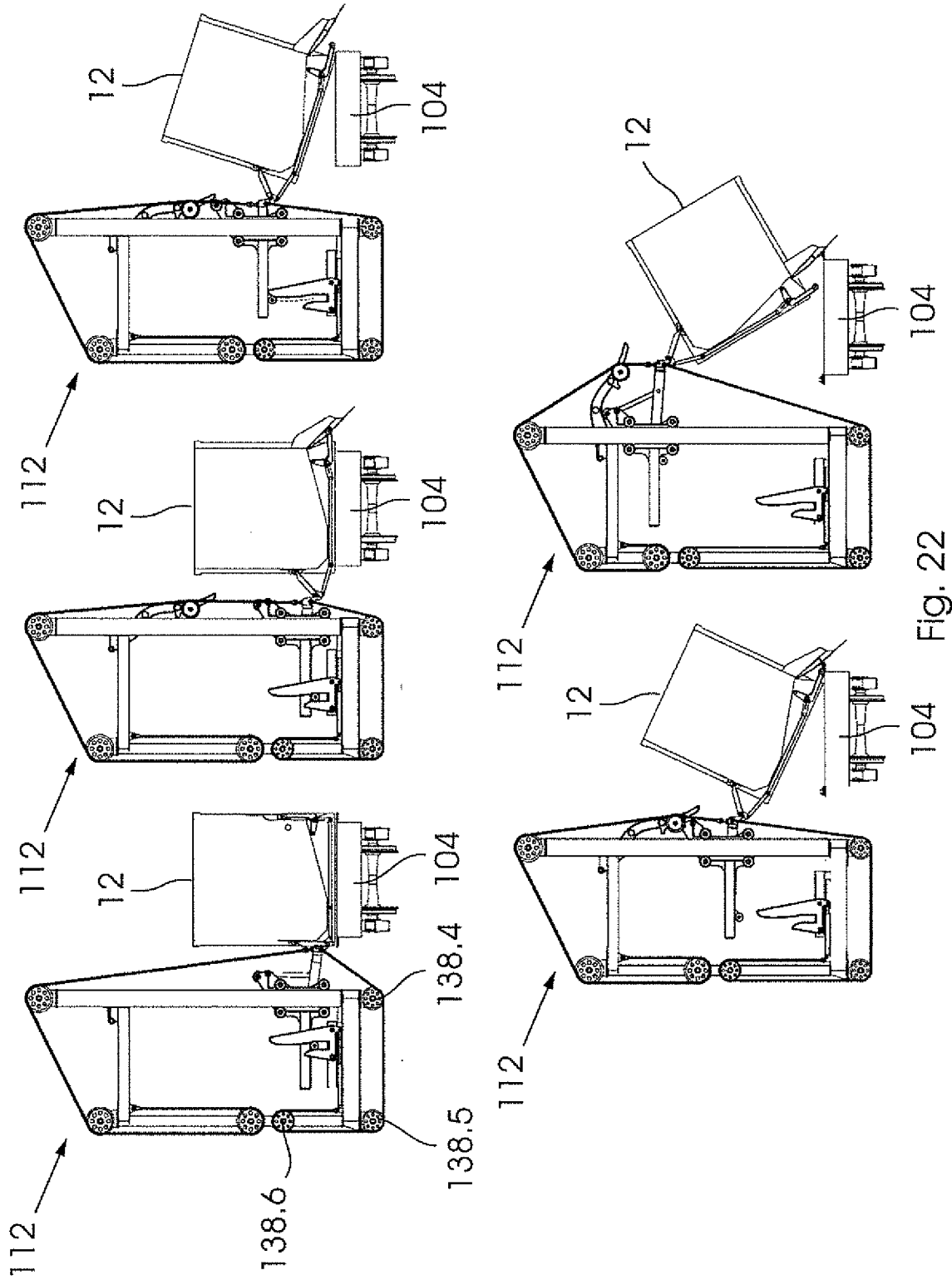

Fig. 21





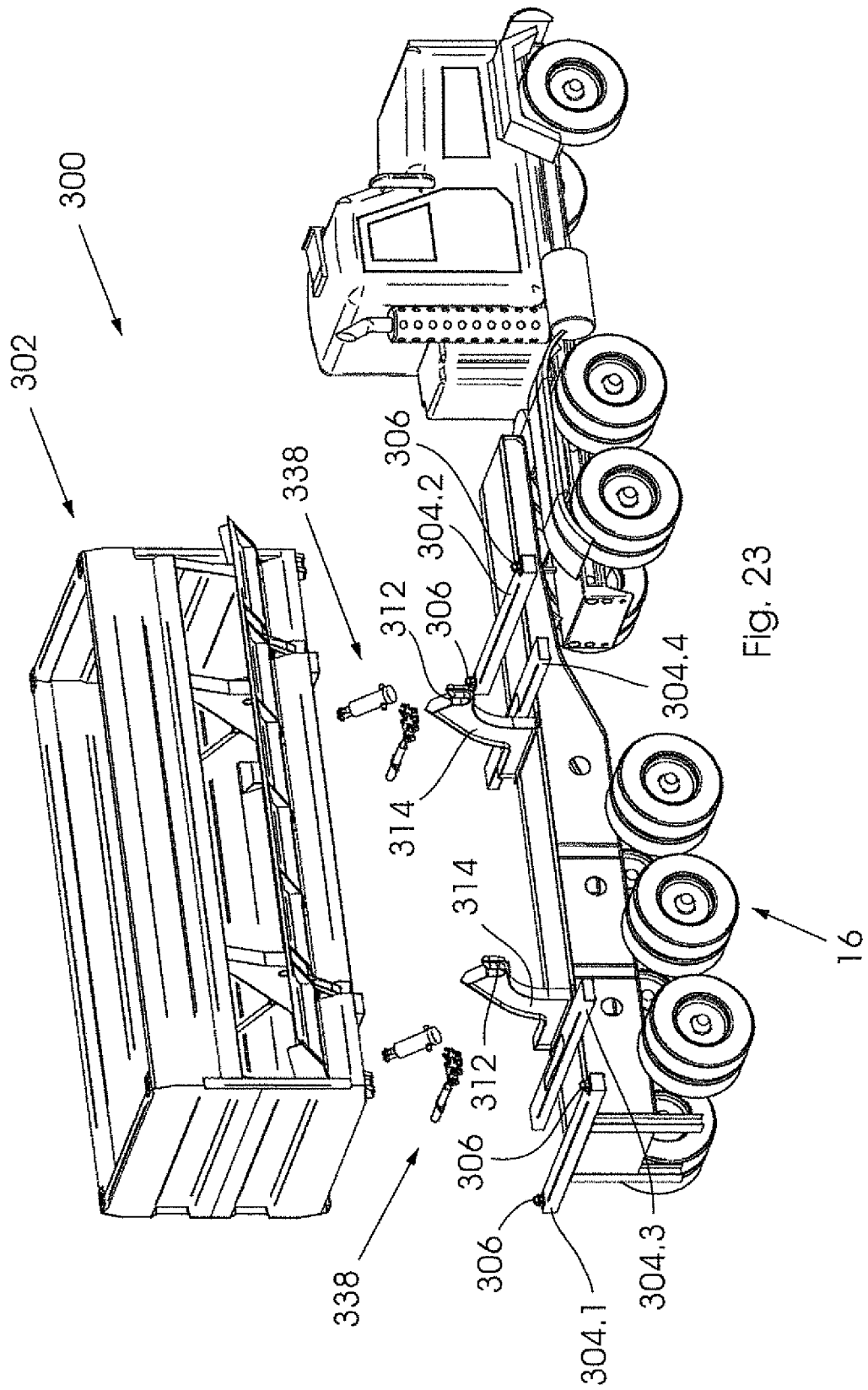
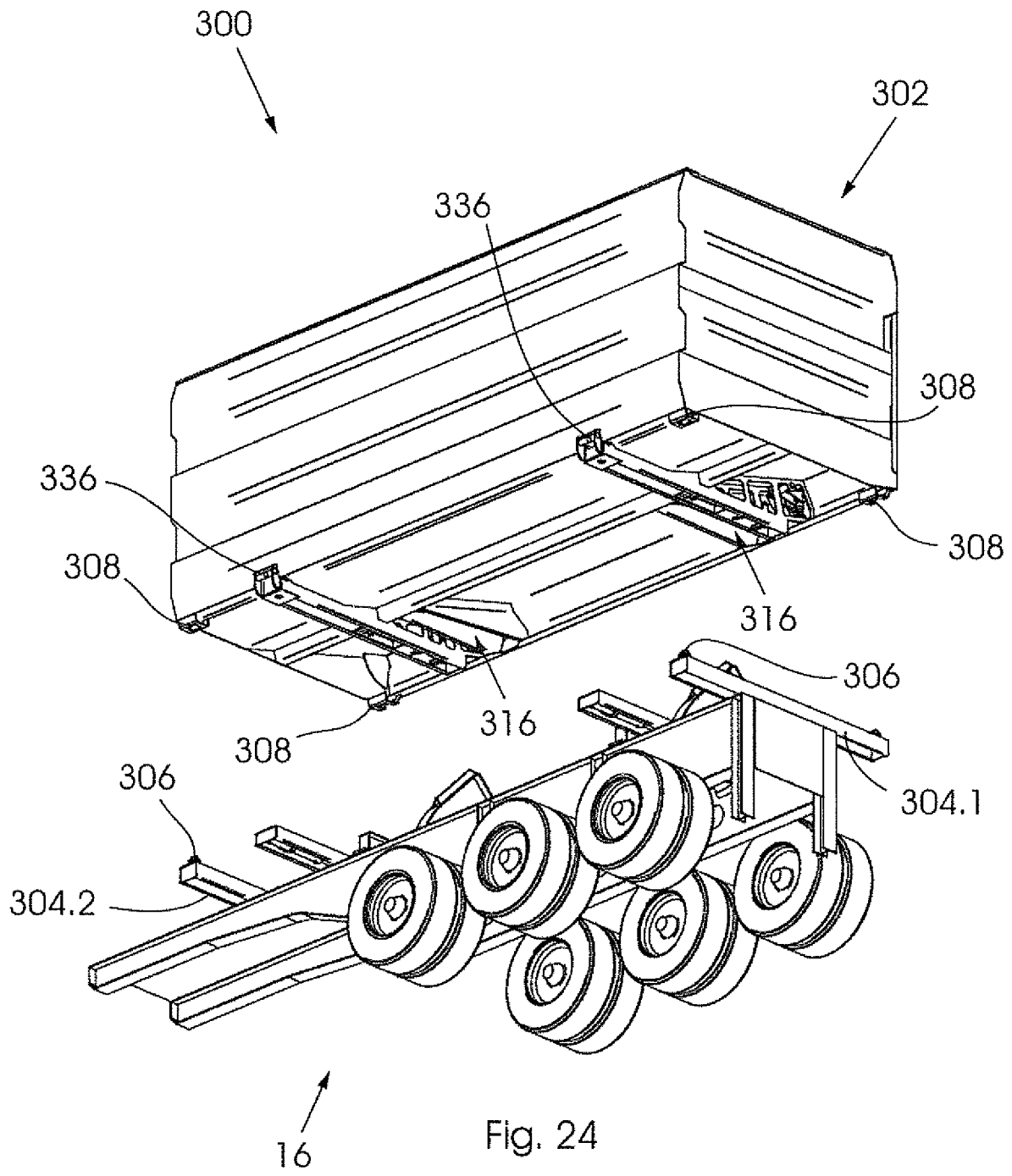

Fig. 23





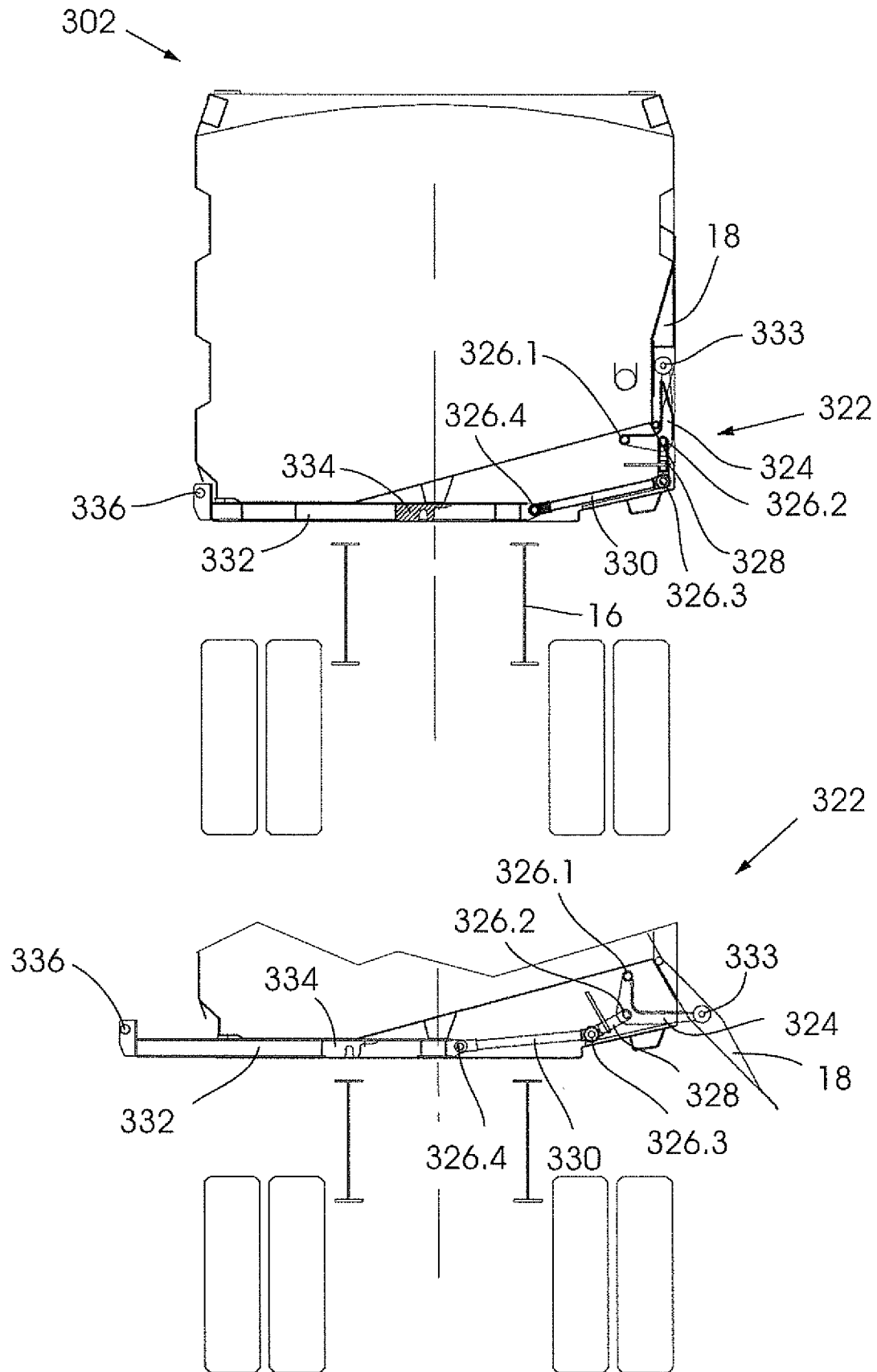

Fig. 26

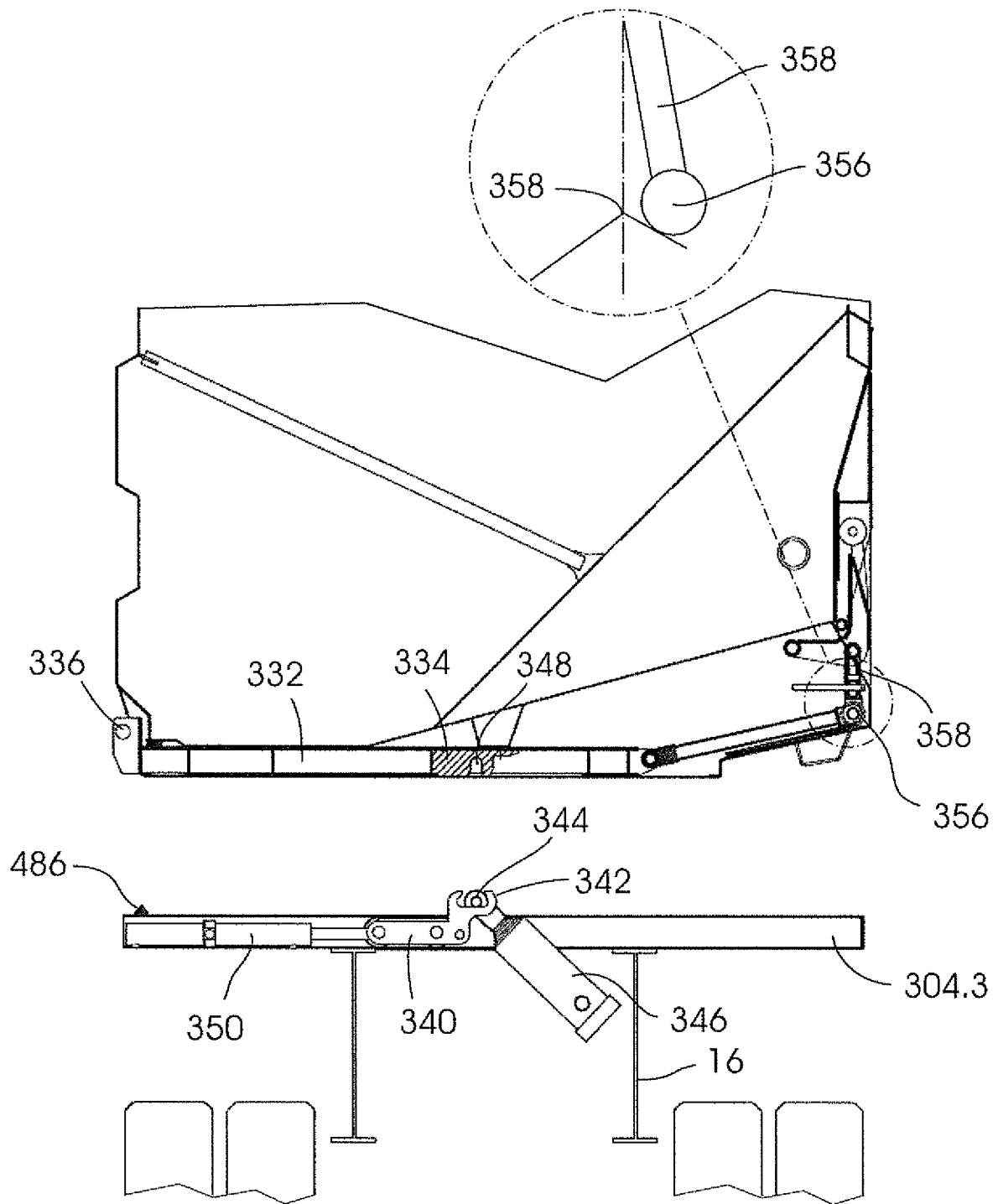

Fig. 27

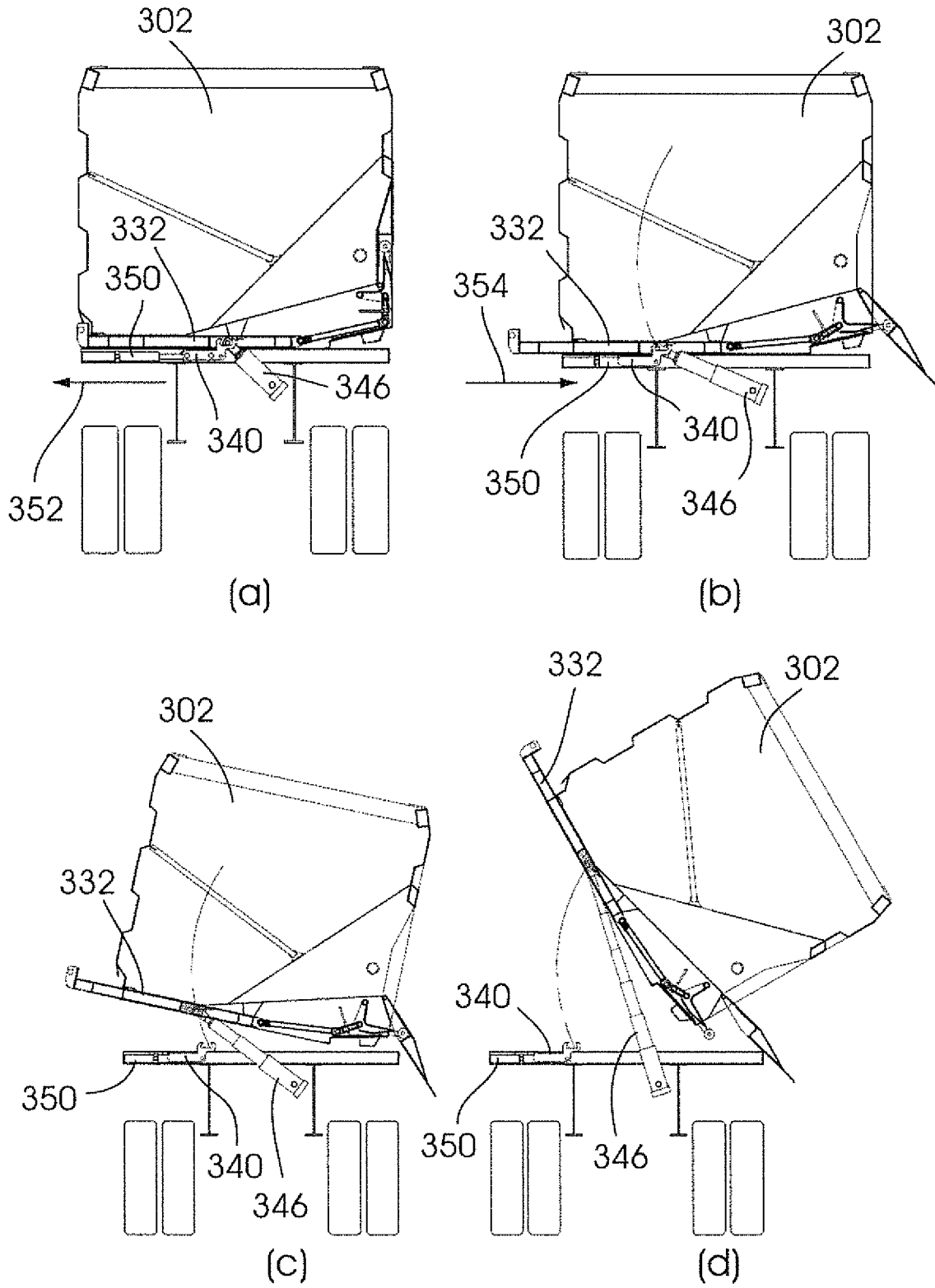

Fig. 28

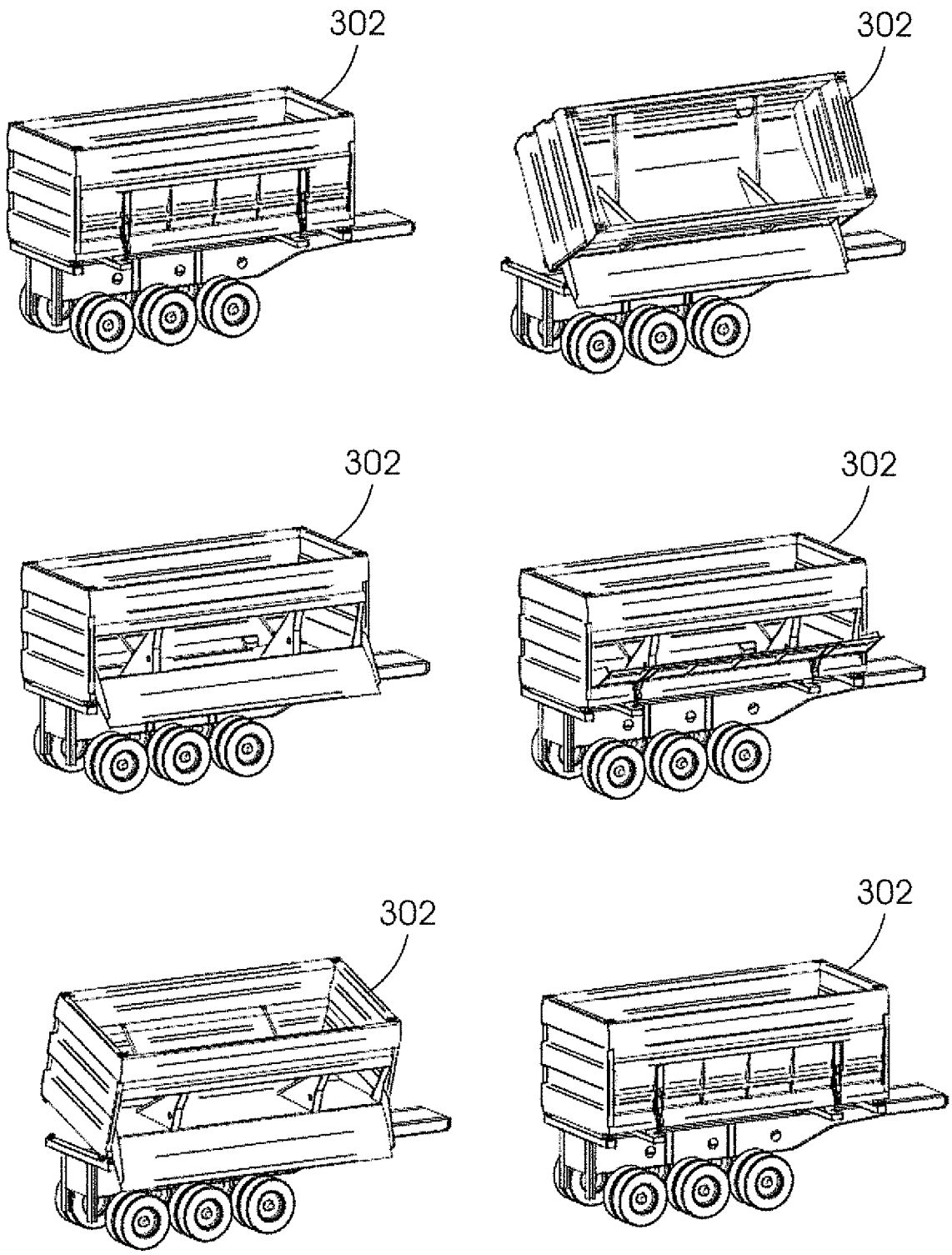

Fig. 29

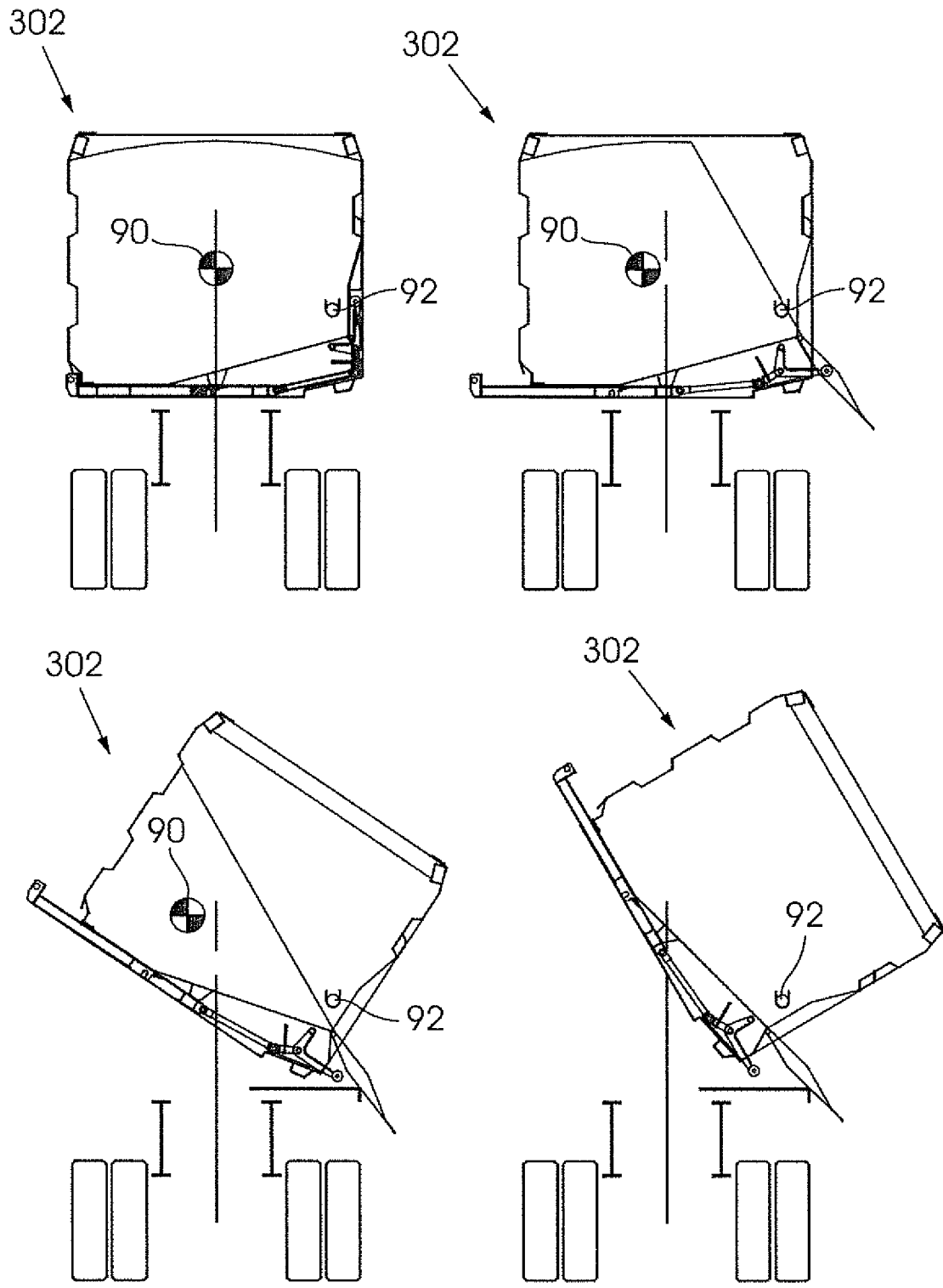

Fig. 30

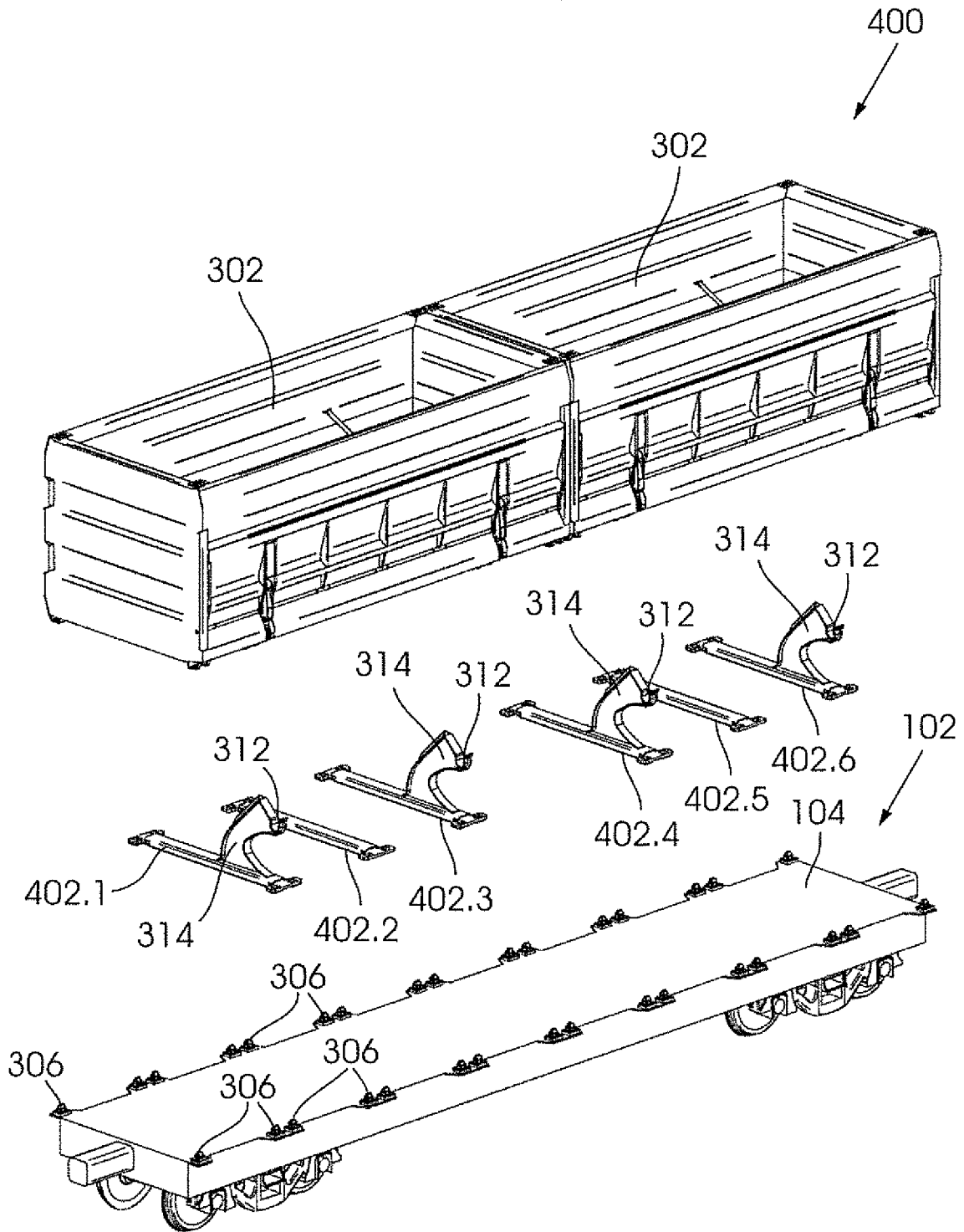

Fig. 31

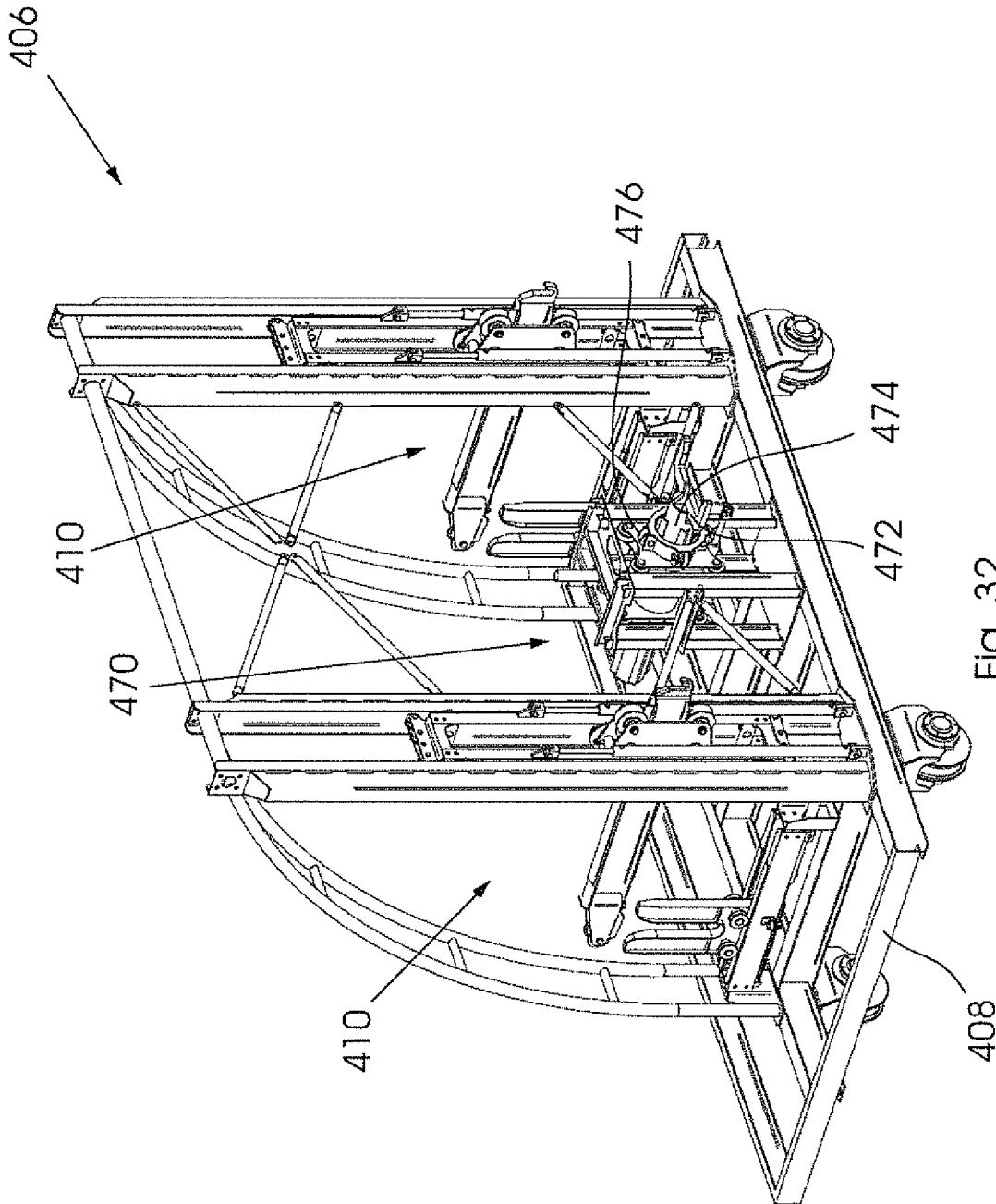

Fig. 32

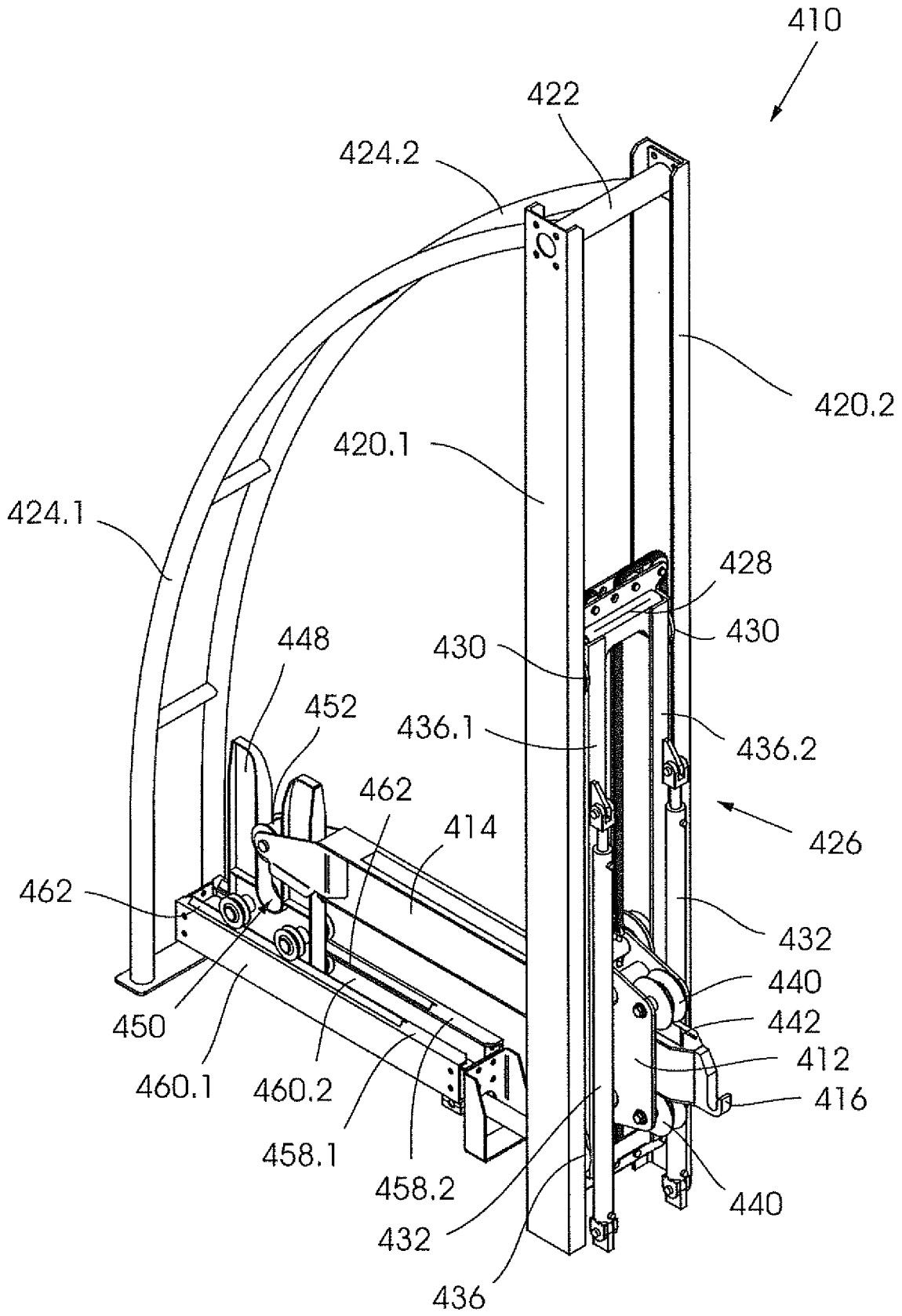

Fig. 33

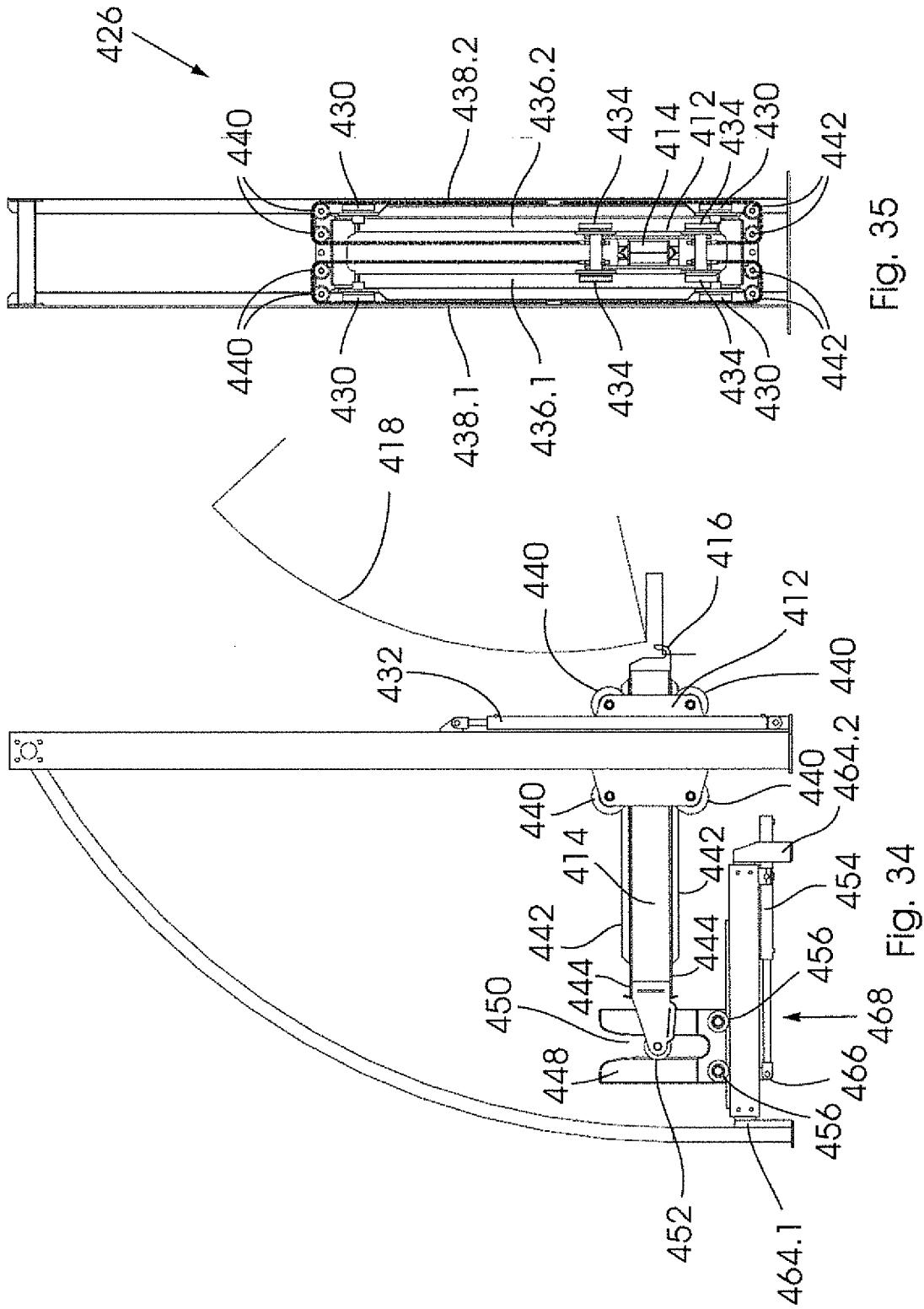

Fig. 35

Fig. 34

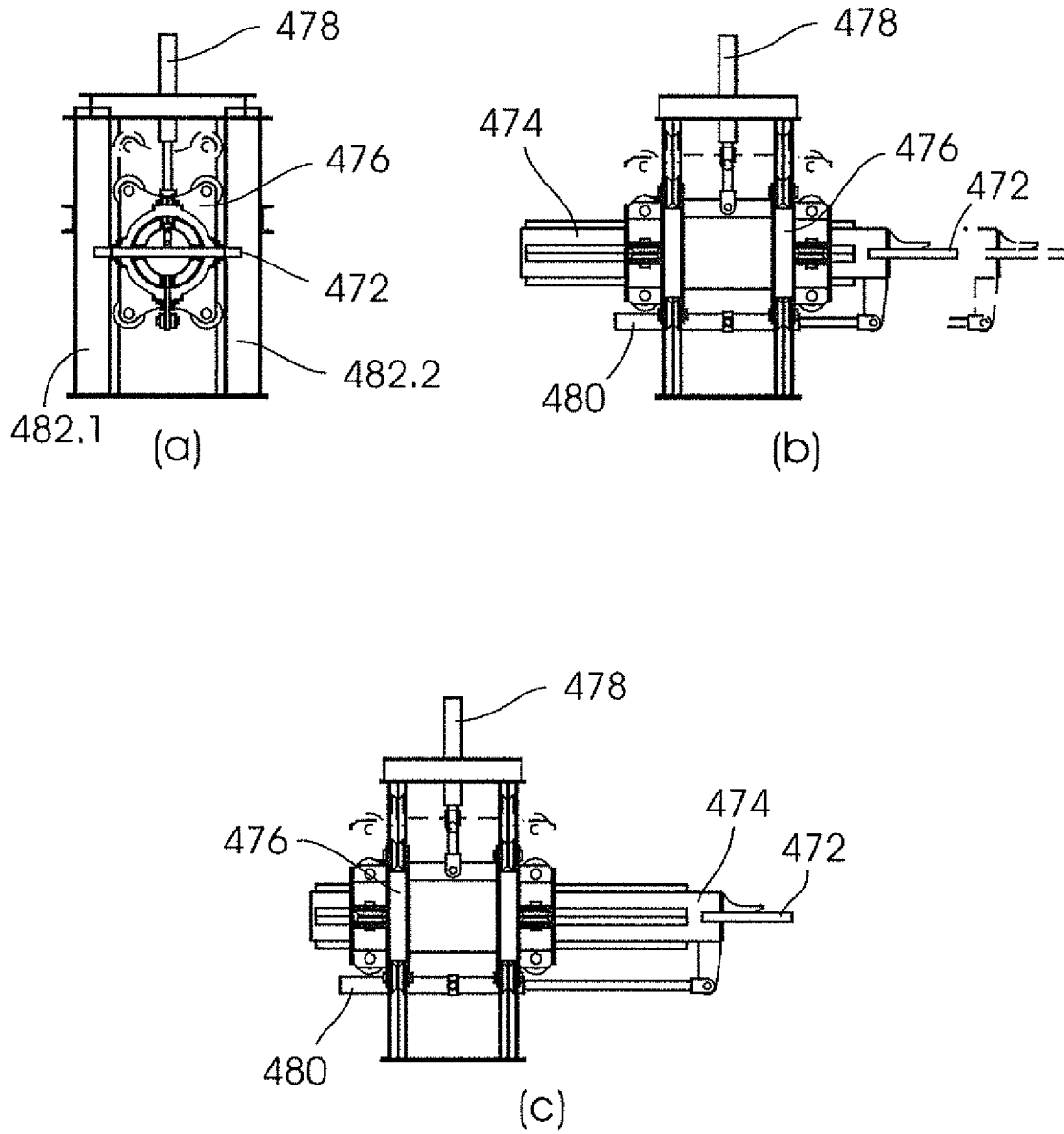

Fig. 36

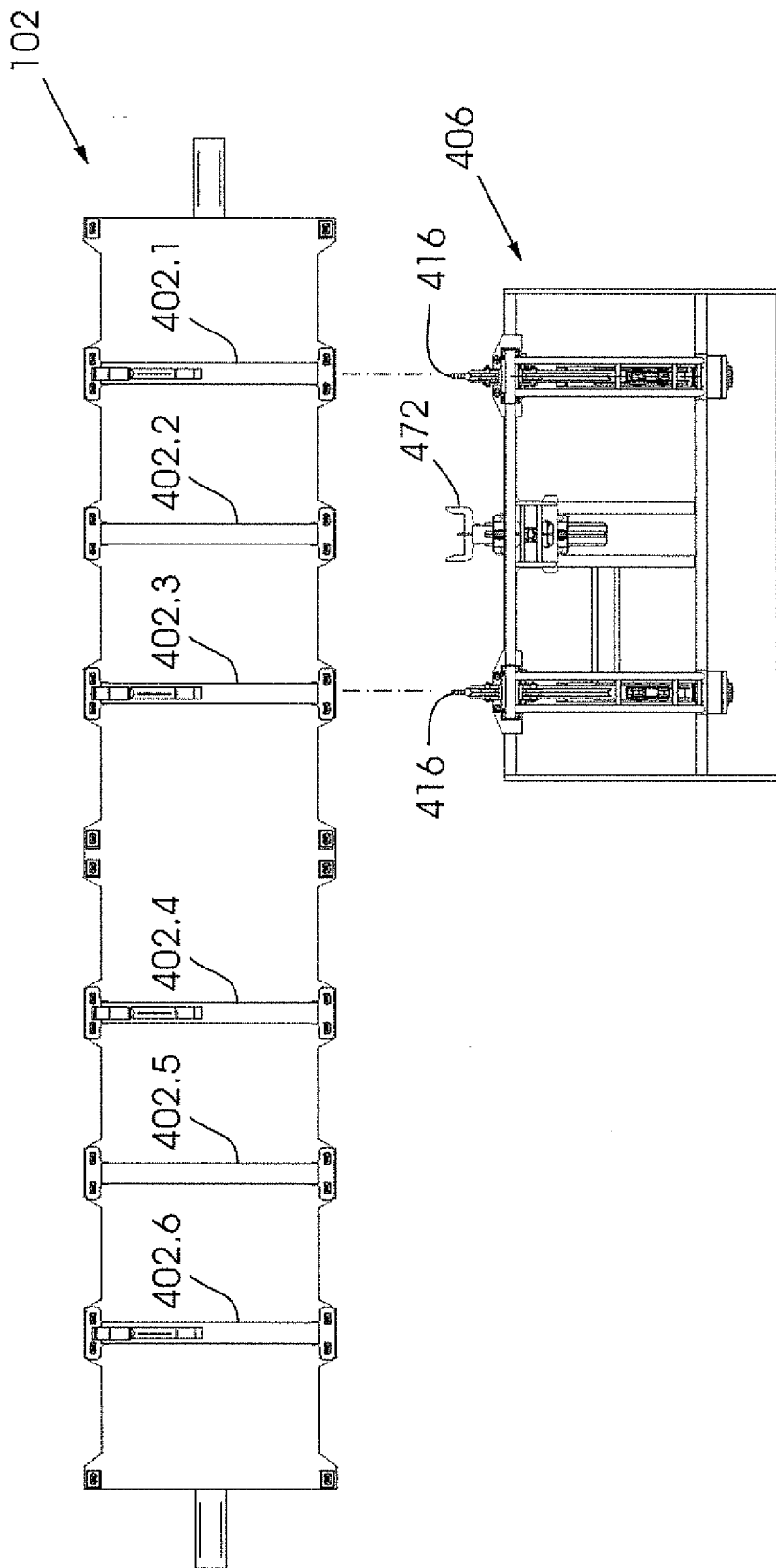

Fig. 37

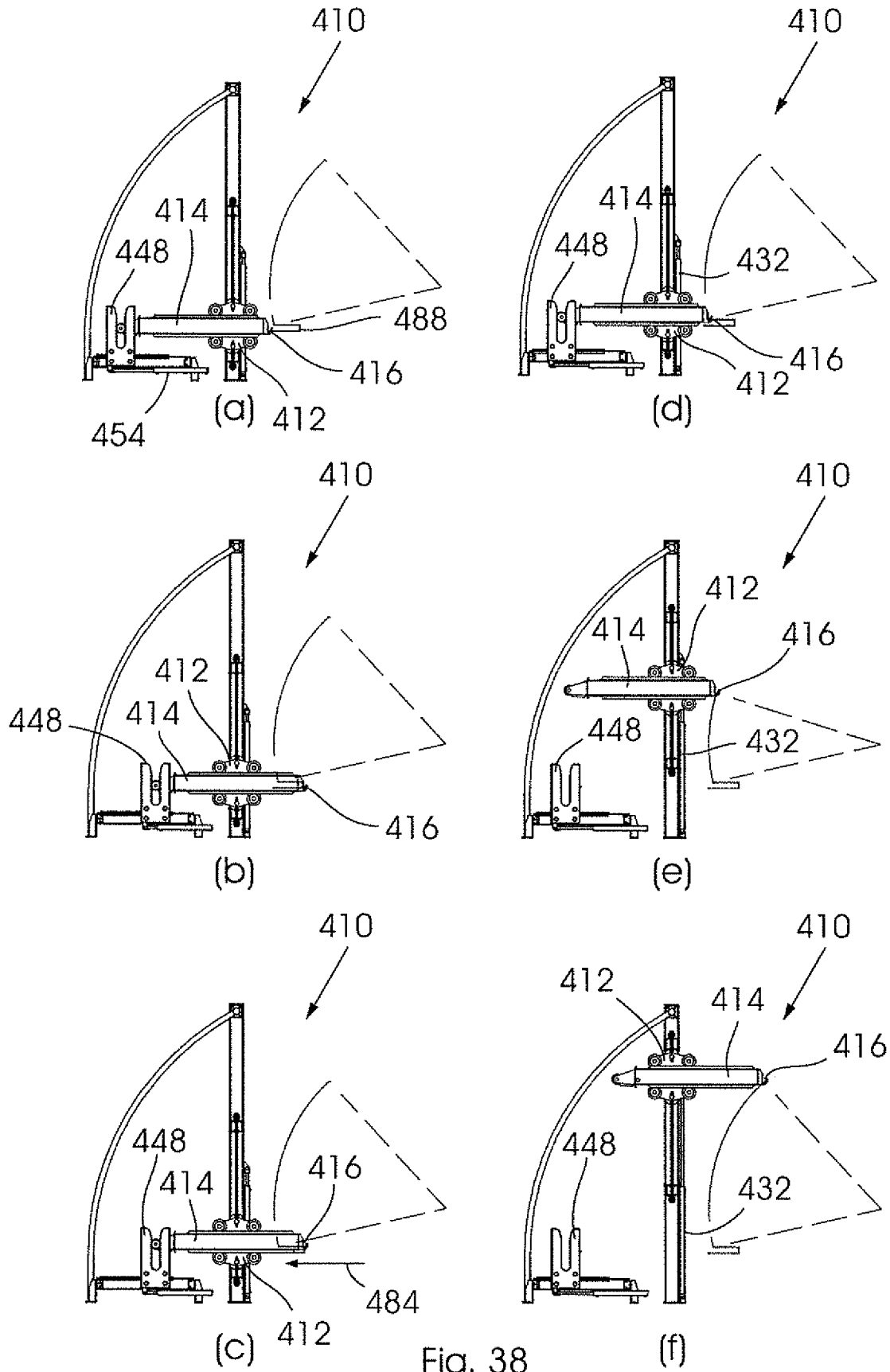
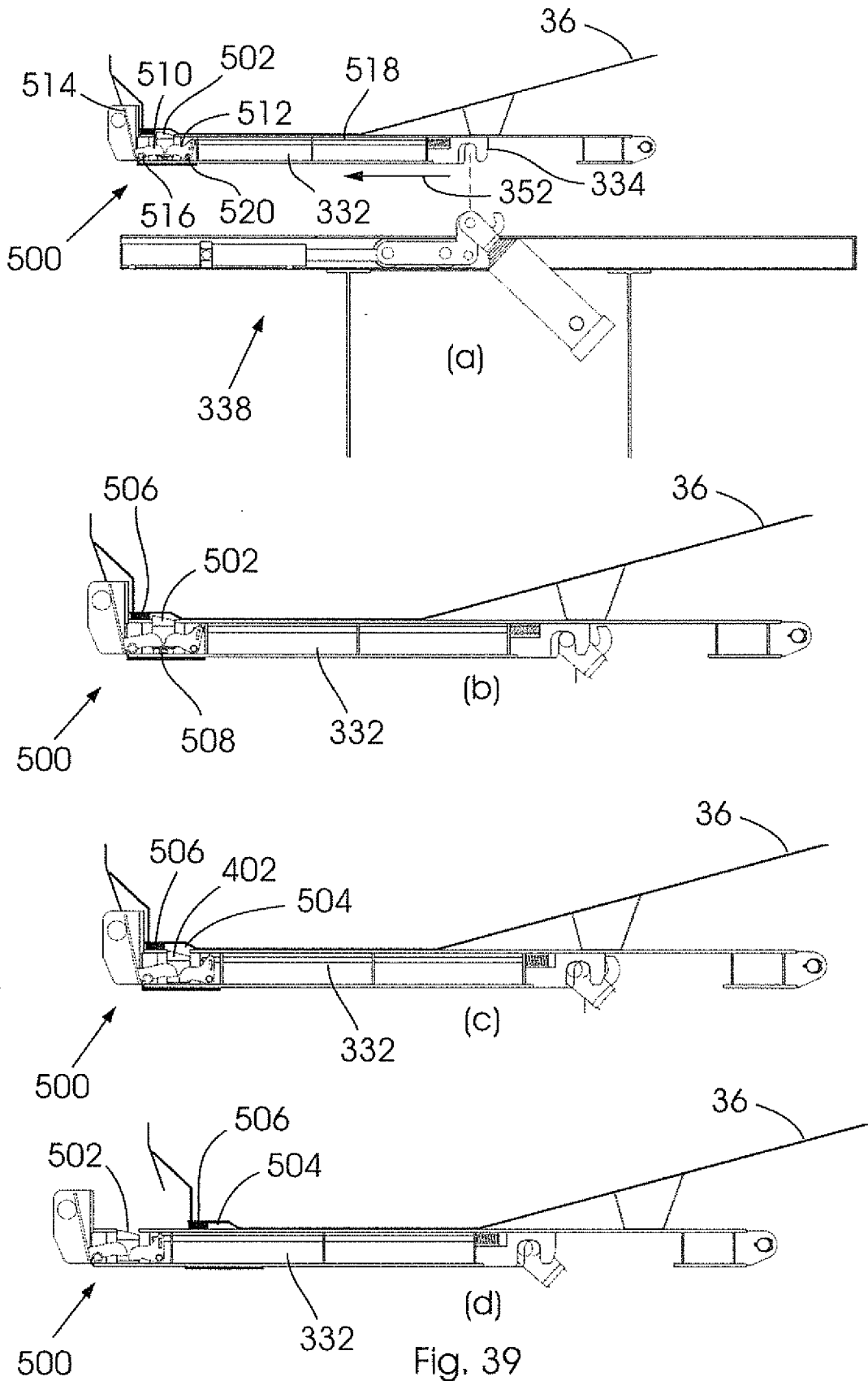

Fig. 38



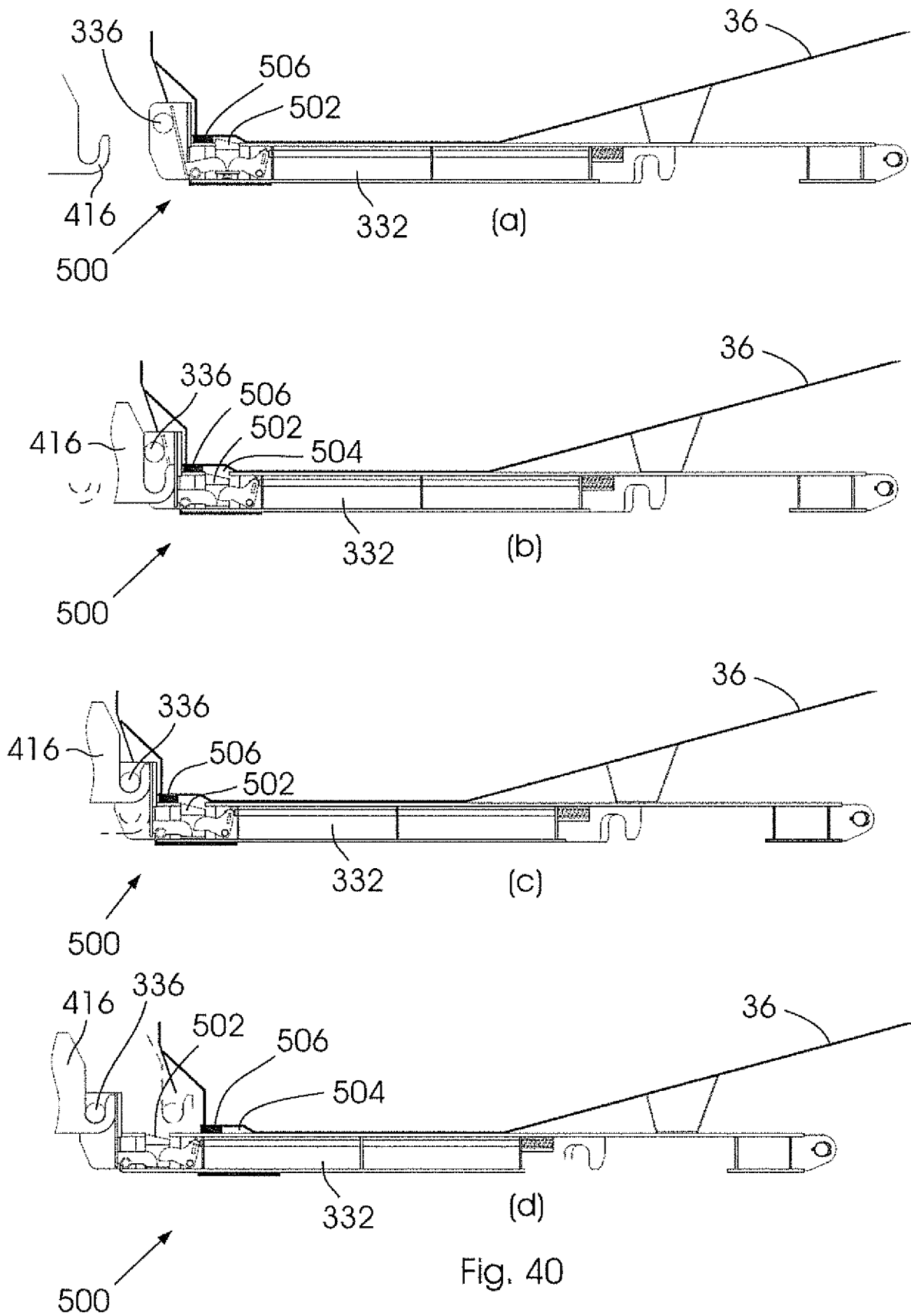

Fig. 40