

Aug. 27, 1963

J. A. LENIZ

3,101,477

DISPENSER AND APPLICATOR FOR THUMB TACKS

Filed Nov. 17, 1961

Fig. 1

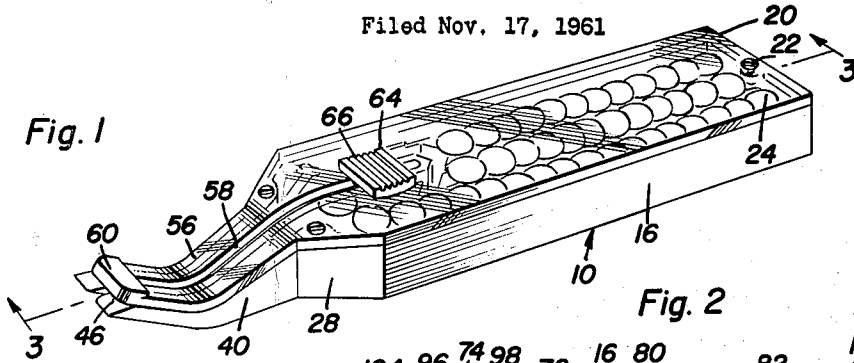

Fig. 2

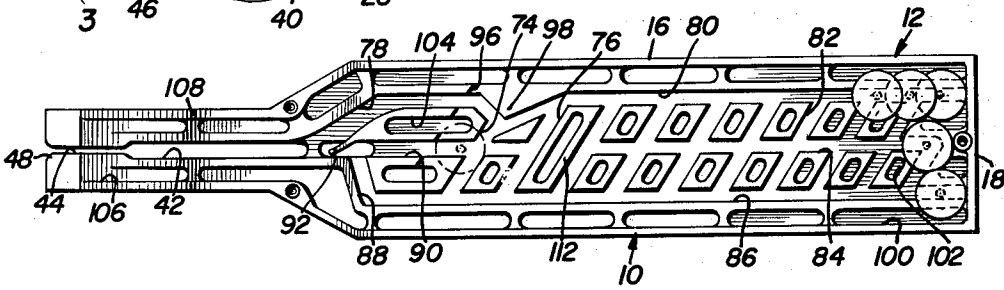

Fig. 3

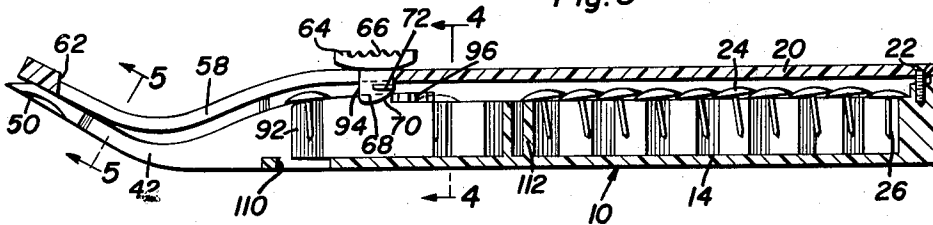

Fig. 4

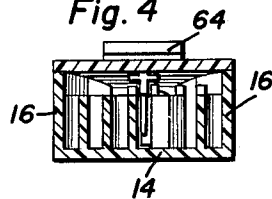
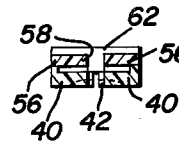

Fig. 5



Joe A. Leniz  
INVENTOR.

BY *Thomas A. Edison*  
*and Harvey R. Jacobson*  
Attorneys

Fig. 6

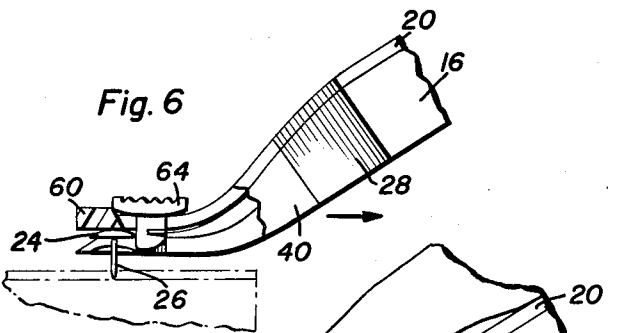
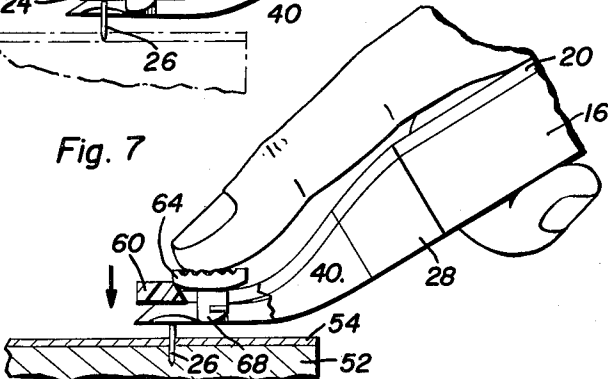

Fig. 7



1

2

3,101,477  
DISPENSER AND APPLICATOR FOR  
THUMB TACKS

Joe A. Leniz, % Leniz Tool Mfg. Co., Inc.,  
P.O. Box 2445, Reno, Nev.  
Filed Nov. 17, 1961, Ser. No. 153,157  
7 Claims. (Cl. 1-46)

The present invention generally relates to a dispenser and applicator for thumb tacks and more particularly to novel improvements over that device disclosed in co-pending application Serial No. 809,557, filed April 28, 1959 for Combination Thumb Tack Dispenser and Applicator, now Patent No. 3,009,155 issued November 21, 1961 and this application constitutes a continuation-in-part of the aforesaid application.

The primary object of the present invention is to provide a dispenser and applicator for thumb tacks having a storage compartment for a plurality of thumb tacks together with novel means for individually dispensing a single thumb tack together with a novel structure for enabling return of thumb tacks to the storage compartment or reservoir after said tacks have been removed from a surface in which they were formerly placed.

Another object of the present invention is to provide a thumb tack dispenser and applicator including a body constructed of plastic material with an integral tongue disposed in a dispensing slot for restricting movement of a thumb tack in a direction towards the discharge end of the dispensing slot while providing unrestricted return movement of the thumb tacks back towards the storage compartment.

A further object of the present invention is to provide a thumb tack dispenser and applicator having an elongated one-piece body structure with upstanding projections thereon which are hollow and which define a waffle arrangement including longitudinal channels and transversely inclined or diagonal channels for directing the thumb tacks towards a supply channel communicated with the dispensing slot or groove at the forward end thereof.

Yet another feature of the present invention is to provide a diagonally inclined abutment for preventing tacks from moving into a channel which directly communicates the dispensing slot with the storage channels at a point forwardly of the restricting tongue whereby tacks may move from the outer end of the dispensing slot unrestrictedly back to the storage compartment but cannot move back into the dispensing slot without passing through the supply channel which discharges into the dispensing slot rearwardly of the restricting tongue thus requiring movement of the slide for forcing the individual thumb tacks past the tongue.

Another very important object of the present invention is to provide a thumb tack applicator and dispenser which is relatively simple in construction, easy to manipulate, foolproof in operation, effective in handling tacks and relatively inexpensive to manufacture.

These together with other objects and advantages which will become subsequently apparent reside in the details of construction and operation as more fully hereinafter described and claimed, reference being had to the accompanying drawing forming a part hereof, wherein like numerals refer to like parts throughout, and in which:

FIGURE 1 is a perspective view of the dispenser and applicator for thumb tacks of the present invention;

FIGURE 2 is a top plan view of the construction of the present invention with the top or cover removed;

FIGURE 3 is a longitudinal, sectional view taken substantially upon a plane passing along section line 3-3 of FIGURE 1 illustrating the relationship of the components of the invention;

FIGURE 4 is a transverse, sectional view taken substantially upon a plane passing along section line 4-4 of FIGURE 3;

FIGURE 5 is a transverse, sectional view taken substantially upon a plane passing along section line 5-5 of FIGURE 3;

FIGURE 6 is a fragmentary side elevational view with portions thereof broken away illustrating the initial step in applying a thumb tack; and

FIGURE 7 is a view similar to FIGURE 6 but illustrating the thumb tack applicator finishing the application of the thumb tack.

Referring now specifically to the drawings, the numeral 10 generally designates the thumb tack dispenser and applicator of the present invention which includes a generally elongated hollow housing designated by reference numeral 12 and including a bottom wall 14, side walls 16 and one end wall 18 disposed perpendicularly to the side walls 16 and the bottom wall 14. Overlying the housing or storage compartment formed thereby is a cover or lid 20 attached to the housing 12 by virtue of a plurality of screw threaded fasteners 22. Any suitable means may be provided for securing the cover or lid in place and the cover or lid 20 is preferably transparent to reveal a plurality of thumb tacks 24 received in the housing. Each thumb tack 24 is provided with a depending pointed shank or stem 26 and is conventional in nature. The entire device may be constructed of plastic material of any suitable thickness or color.

The forward ends of the side walls 16 terminate in inwardly inclined portions 28 and longitudinal generally arcuate extensions 40. The extensions 40 are spaced from each other to define a dispensing slot 42 and the outer end portion of the dispensing slot 42 is narrowed as at 44 for retaining a thumb tack stem 26 in place during application and removal thereof. The outer ends of the arcuate extensions 40 are tapered as at 46 to form a cam surface used in removing thumb tacks from a supporting surface. The entrance to the narrowed slot 44 has rounded corners 48 to facilitate the insertion of the forward edge portions of the extensions 40 under a thumb tack whereby the head of the thumb tack will ride up the cam surface 46 and over the top surface of the extensions whereby the thumb tack may be easily removed. The undersurface of the extensions 40 have a rounded recess 50 therein for receiving the head of a thumb tack as illustrated in FIGURE 7 for positioning the applicator in relation to a thumb tack for forcing the thumb tack completely into a supporting surface such as designated by numeral 52 for holding a sign or other paper panel 54 in place thereon.

The cover or lid 20 is provided with a longitudinal arcuate extension 56 overlying the top surface of the extensions 40 and the extension 56 is provided with a slot 58 overlying the dispensing slot 42. The outer end of the slot 58 is closed by a transverse end member 60 having a greater thickness than the extension 56 thereby forming an abutment or shoulder 62 to limit the sliding movement of a slide 64 in the slot 58. The slide 64 is provided with a plurality of serrations 66 on the top surface thereof for ease of gripping and also a depending blade 68 extends downwardly through the slot 56 and into the slot 42. The depending blade 68 is provided with a rounded rear corner 70 and also a transverse retainer 72 for preventing the blade 68 from being withdrawn upwardly through the slot 58. The rounded corner 70 enables the slide 64 to be withdrawn to the rear end of the slot 58 which overlies the forward portion of the housing 12 intermediate the forward ends of the side walls 16. The rear end of the slot 58 forms a limit for the rearward movement of the slide 64 and the dispensing slot 42 extends rearwardly into the main portion of the

housing 12 which may be considered a storage compartment and communicates with transverse diagonal channels 74 and 76.

The dispensing slot 42 is communicated with an angulated return slot 78 disposed adjacent one side of the housing or storage compartment and the return slot 78 communicates with a longitudinal storage channel 80. The return slot or channel 78 provides for unrestricted return of thumb tacks from the dispensing slot 42 into the storage channel 80 or any of a plurality of transversely inclined storage channels 82. A central storage channel 84 is provided and also, a storage channel 86 is provided adjacent the opposite side of the housing. The storage channel 86 communicates with an inwardly extending supply or delivery channel 88 which will supply tacks into the dispensing slot 42 and into the dispensing channel 90 which forms the extension of the dispensing slot 42 and which actually communicates the transverse inclined channels 74 and 76 with the slot 42. As illustrated in FIGURE 2, there is provided an integral tongue 92 of plastic material which has a free end disposed adjacent but slightly spaced from the wall of the slot 42 and the tongue 92 extends diagonally across the rear end of the dispensing slot 42 and is disposed forwardly of the delivery or supply channel 88 and forwardly of the supply channel 90. The tongue 92 is disposed rearwardly of the return channel 78 and, in fact, forms one wall thereof at the forward end of the delivery channel. Thus, in order for thumb tacks to be discharged from the delivery channel 88 or the delivery channel 90 into the dispensing slot 42, such thumb tacks must be forced past the tongue 92 which requires that sufficient longitudinal force be applied on the tacks to resiliently spring the plastic tongue 92 slightly thus enabling the stem 26 to pass between the free end of the tongue 92 and the adjacent wall of the dispensing slot 42. This force is applied by the straight forward edge 94 of the blade 68 during forward movement thereof. The rounded surface 70 of the blade 68 enables it to ride over the tongue 62 during its return movement into the rear end of the slot 58 thereby enabling the slide 64 to move longitudinally in the slot 58.

At the forward end of the housing or storage compartment, the walls which define the channels 78, 90 and 86 define a transversely inclined shoulder 96 which will guide the heads of the thumb tacks laterally into the storage channel 86 or delivery channel 88 when the thumb tack dispenser and applicator is held with the forward end thereof downwardly inclined so that gravity will cause the thumb tacks to move forwardly and towards the delivery channel 88. Thus, any thumb tack endeavoring to move forwardly into the return channel 78 will be effectively stopped. The junction between the return channel 78 and the storage channel 80 is provided with an inwardly extending guide projection 98 which will guide any thumb tacks proceeding down the channel 80 into the inclined transverse channel 74.

The entire housing is of one-piece unitary construction as is the cover or lid 20 with the slide 64 being an independent component which is permanently assembled with the cover or lid. Various portions of the housing have hollow areas formed therein such as areas 100, 102 and 104 all of which serve to save material and also provide lightness to the article and at the same time provide a novel and highly interesting ornamental waffle effect. Such hollow areas may be formed in the projections and also the projections 40 have longitudinal recessed areas 106 defined by side edges 108 which meet with and engage the undersurface of the extension 56 on the cover 20 thus providing a continuous contact between the housing and the cover with the tip end of the extension 56 including the abutment 60 normally engaging the top surface of the tip end portion of the extensions 40 thereby resiliently retaining a tack in position so that the head thereof will force its way between the tip ends of the extensions 40 and the tip end of the extension 56 thus facilitating the application and removal of thumb tacks.

As illustrated in FIGURE 3, the bottom wall 14 is provided with a slot 110 in alignment with the bottom of the tongue 92 thus assuring that the tongue will be sufficiently flexible to enable the thumb tack to pass after a predetermined force has been applied thereto. Thus, the tongue or finger is not attached to the bottom wall but only to one of the upstanding partition blocks formed integral with the bottom wall.

In this construction, delivery of the tacks occurs from the left side while return of the tacks occurs to the right side. The triangular projection or diverter 98 diverts forwardly moving thumb tacks into the forwardmost diagonal channel 74 and cooperates with the oblique angle formed by the abutments 96 to guide the thumb tacks to the left or to the delivery channel thereby preventing thumb tacks from moving forwardly through the return channel 78. Thus, when the device is tipped forwardly and downwardly such as in normal use, thumb tacks will not escape out through the return channel 78. As illustrated, the rear of the inclined channel 76 is blocked by a continuous transverse block 112 which serves to prevent a plurality of thumb tacks from moving forwardly in the center channel and becoming jammed behind the slide 64. The oblique angle of the waffle grid pattern also serves to guide the thumb tacks to the left when the device is tipped forward and guiding them to the right when it is tipped up in front. This waffle pattern also assists in distributing the thumb tacks in the three storage channels 80, 84 and 86 and the thumb tacks will be quite evenly distributed by virtue of the waffle arrangement and the particular arrangement of the longitudinal channels and the inclined transverse channels.

The foregoing is considered as illustrative only of the principles of the invention. Further, since numerous modifications and changes will readily occur to those skilled in the art, it is not desired to limit the invention to the exact construction and operation shown and described, and accordingly, all suitable modifications and equivalents may be resorted to, falling within the scope of the invention as claimed.

What is claimed as new is as follows:

1. A dispenser and applicator for thumb tacks comprising a housing having a storage compartment including channels for slidably receiving the stems of thumb tacks, at least one of said channels terminating at its forward end in a delivery channel, said housing including a dispensing slot communicating with the delivery channel and having a discharge end remote from the delivery channel, at least one of said channels in the housing terminating at its forward end in a return channel, said return channel having a forward end portion inclined towards the dispensing slot, the forward end portion of said return channel being communicated with the dispensing slot longitudinally outwardly of the point of communication between the forward end portion of the delivery channel and the dispensing slot, said housing including a top slot overlying the dispensing slot, a slide slidably mounted in the slot overlying the dispensing slot whereby the slide may engage tacks and move them forwardly in the dispensing slot, and resilient tongue means mounted in said dispensing slot intermediate the point of communication of the delivery channel therewith and the point of communication of the return channel therewith thereby restricting flow of tacks from the delivery channel into the dispensing slot and providing free return of tacks from the dispensing slot into the return channel.

2. The structure as defined in claim 1 wherein said housing includes diagonally inclined deflector means spaced rearwardly from the tongue means to prevent forward movement of thumb tacks from the storage compartment into the return channel.

3. The structure as defined in claim 1 wherein said housing includes a transversely inclined abutment at the forward portion of the storage chamber but rearwardly of the tongue means to engage the heads of forwardly

5

moving thumb tacks for deflecting the tacks toward the delivery channel.

4. The structure as defined in claim 1 wherein said storage compartment includes a plurality of transversely inclined channels extending forwardly and toward the delivery channel whereby tacks will be directed toward the delivery channel when they move forwardly and spread laterally when they move rearwardly.

5. The structure as defined in claim 1 wherein said tongue means includes a tongue of unitary construction with the housing and having a top and bottom edge free of the housing to provide flexibility thereto, said tongue partially blocking the dispensing slot and being inclined toward the discharge end of the dispensing slot and toward the side of the dispensing slot with which the delivery channel communicates.

6. The structure as defined in claim 5 wherein said slide includes a depending blade slidable in the dispensing slot for forcing thumb tacks past said tongue, the rear bottom corner of said blade being rounded to facilitate the passage of the blade over the tongue when the slide is retracted.

7. A dispenser and applicator for thumb tacks comprising an elongated housing having a storage compartment including channels for slidably receiving the stems of thumb tacks, at least one of said channels terminating at its forward end in a delivery channel, at least one other of said channels in the housing terminating at its forward end in a return channel, said housing also including a dispensing slot communicating with both the delivery channel and the return channel, said dispensing slot having a discharge end remote from the delivery and return channel, said delivery channel being dis-

6

posed adjacent one side of the housing and the forward end portion thereof being inclined inwardly toward the dispensing slot and communicating therewith, said return channel having an inclined forward end portion extending inwardly toward and communicating with the dispensing slot, said housing including a resilient tongue defining a portion of the forward end of the return channel and having the free end thereof disposed adjacent to the side of the dispensing slot with which the delivery channel communicates thereby forming a resilient obstruction to passage of thumb tack stems from the delivery channel into the dispensing slot, said tongue, in its normal position, defining unrestricted guide means for thumb tacks returning from the dispensing slot thereby guiding such thumb tacks unrestrictedly into the return channel, a slide mounted on the housing and including a blade extending into the housing for engaging thumb tacks and moving them longitudinally in the dispensing slot, said blade being movable past the top whereby thumb tacks entering the dispensing slot from the delivery channel may be engaged by the blade and moved longitudinally outwardly thereof thus biasing the tongue away from the wall of the dispensing slot thereby enabling discharge of thumb tacks from the delivery channel, said blade, when disposed rearwardly of the tongue, permitting unrestricted movement of thumb tacks from the dispensing slot into the return channel.

References Cited in the file of this patent

UNITED STATES PATENTS

3,009,155      Leniz ----- Nov. 21, 1961