

McCONAUGHY & McCOLLUM.

Carriage-Wheel.

No. 20,652.

Patented June 22, 1858.

Fig. 1.

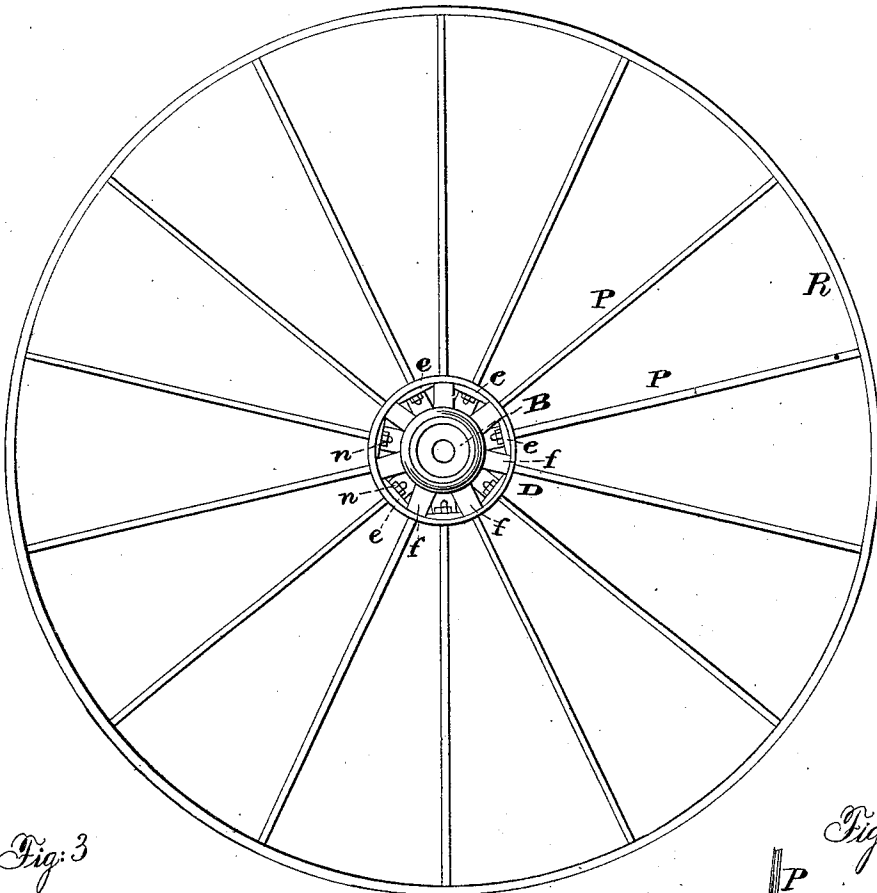

Fig. 3.

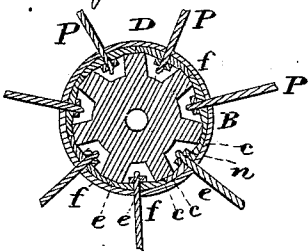

Fig. 4.

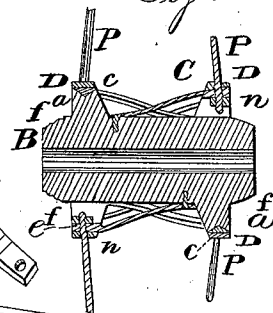

Fig. 5. c

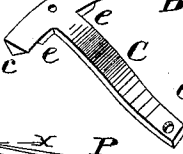
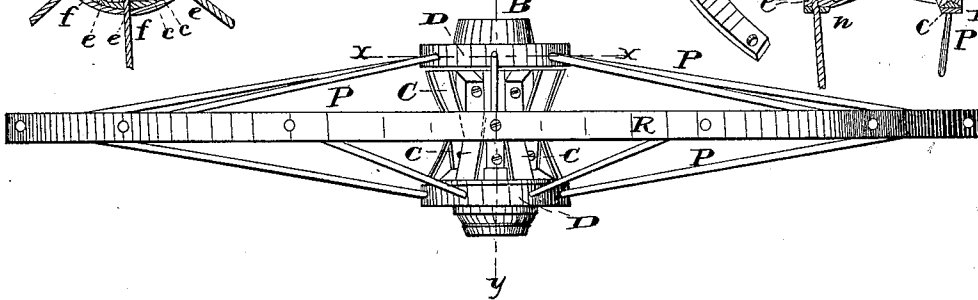

Fig. 2.



UNITED STATES PATENT OFFICE.

T. McCONAUGHY AND J. McCOLLUM, OF BURNSVILLE, ALABAMA.

METALLIC WHEEL FOR VEHICLES.

Specification of Letters Patent No. 20,652, dated June 22, 1858.

To all whom it may concern:

Be it known that we, THOMAS McCONAUGHY and JAMES McCOLLUM, of Burnsville, in the county of Dallas and State of Alabama, have invented a new and useful Improvement in Wheels for Vehicles; and we do hereby declare that the following is a full, clear, and exact description of the construction and operation of the same, reference being had to the annexed drawing, forming part of this specification, in which—

Figure 1 is a side view of the wheel. Fig. 2 is a top view of same. Fig. 3 is a section on $x x$ perpendicular to axis. Fig. 4 is a section on $y y$ through axis. Fig. 5 is a view of brace piece detached.

Similar characters of reference in the several figures denote the same part.

Our invention relates to the construction of metallic wheels, and consists in a peculiar combination of devices hereinafter to be set forth.

The wheel consists of a box B, feathered at each extremity, two wrought metal bands shrunk upon the feathers, a system of peculiarly constructed braces, and a wrought metal rim R connected with the central portion by screw rods.

The box B is to be formed of cast metal, the extremities of the feathers f being made with grooves as shown at a in Fig. 4 for the reception of the double inclined under surface of the extremities c of the brace head.

The brace C consists of a shank and head, and is attached to the box by a bolt through the shank, or otherwise. The upper surface of the brace head is curved to correspond with the radius of the band D, and its under surface is made up of a flat portion e and two V-shaped extremities. These extremi-

ties c are of such dimensions as to occupy half of the groove in the extremity of the feather f , and when in position bring the upper surface of the extremity of the head flush with the extremity of the feather. The flat portion e filling the space between the feathers.

The wrought metal bands C are shrunk upon the extremities of the feathers, forcing the V shaped projections into the grooves and firmly binding the whole together. The holes for the rods P are made through both band and brace head and the rim R attached by tightening the nuts w against the flat surfaces e of the brace heads; the several parts having the positions shown in Fig. 4.

The manner in which the brace head is connected with the feathers and band causes it to perform the functions of strengthening the feathers and preventing the slipping of the band, in addition to its providing a flat bearing surface for the nut of the screw rod.

What we claim as our invention and desire to secure by Letters Patent, is—

The combination of the feathered box, wrought metal bands and system of braces C, with the screw rods and rim of the wheel; constructed, arranged and operating substantially as, and for the purpose set forth.

In testimony whereof, we have hereunto signed our names before two subscribing witnesses.

THOS. McCONAUGHY.
J. McCOLLUM.

Witnesses to McConaughy:

GEO. PATTEN,
H. L. DENSLER.

Witnesses to McCollum:

I. W. COLE,
JOSIAH DUNN.