

(19) World Intellectual Property  
Organization  
International Bureau



(43) International Publication Date  
13 October 2005 (13.10.2005)

PCT

(10) International Publication Number  
**WO 2005/095284 A1**

- (51) International Patent Classification<sup>7</sup>: C02F 1/50, 9/00
- (21) International Application Number:  
PCT/EP2005/002254
- (22) International Filing Date: 1 March 2005 (01.03.2005)
- (25) Filing Language: English
- (26) Publication Language: English
- (30) Priority Data:  
0337/MUM/2004 19 March 2004 (19.03.2004) IN
- (71) Applicant (for AL, AM, AT, AZ, BA, BE, BF, BG, BJ, BR, BY, CF, CG, CH, CI, CM, CN, CO, CR, CU, CZ, DE, DK, DM, DZ, EC, EE, ES, FI, FR, GA, GE, GN, GQ, GR, GW, HR, HU, ID, IS, IT, JP, KG, KP, KR, KZ, LR, LT, LU, LV, MA, MC, MD, MG, MK, ML, MR, MX, MZ, NE, NI, NL, NO, PH, PL, PT, RO, RU, SE, SI, SK, SN, SY, TD, TG, TJ, TM, TN, TR, UA, UZ, VN, YU only): UNILEVER N.V. [NL/NL]; Weena 455, NL-3013 AL Rotterdam (NL).
- (71) Applicant (for AE, AG, AU, BB, BW, BZ, CA, CY, EG, GB, GD, GH, GM, IE, IL, KE, LC, LK, LS, MN, MW, NA, NZ, OM, PG, SC, SD, SG, SL, SZ, TT, TZ, UG, VC, ZA, ZM, ZW only): UNILEVER PLC [GB/GB]; UNILEVER HOUSE, Blackfriars, London, Greater London EC4P 4BQ (GB).
- (71) Applicant (for IN only): HINDUSTAN LEVER LIMITED [IN/IN]; HINDUSTAN LEVER HOUSE, 165/166 Backbay Reclamation Maharashtra, Mumbai 400 020 (IN).
- (71) Applicants (for all designated States except US): MISTRY, Mahendrakumar, Maganlal [IN/IN]; HINDUSTAN LEVER RESEARCH CENTRE, I.C.T. Link Road, Chakala, Andheri East, Mumbai 400 099 (IN). MUKHERJEE, Nihileshwar [IN/IN]; HINDUSTAN LEVER RESEARCH CENTRE, I.C.T. Link Road, Chakala, Andheri East, Mumbai 400 099 (IN). RAVIKUMAR, Dhulipala [IN/IN]; HINDUSTAN LEVER RESEARCH CENTRE, I.C.T. Link Road, Chakala, Andheri East, Mumbai 400 099 (IN). VADHYAR, Jayashree, Anantharam [IN/IN];

[Continued on next page]

(54) Title: WATER PURIFICATION SYSTEM

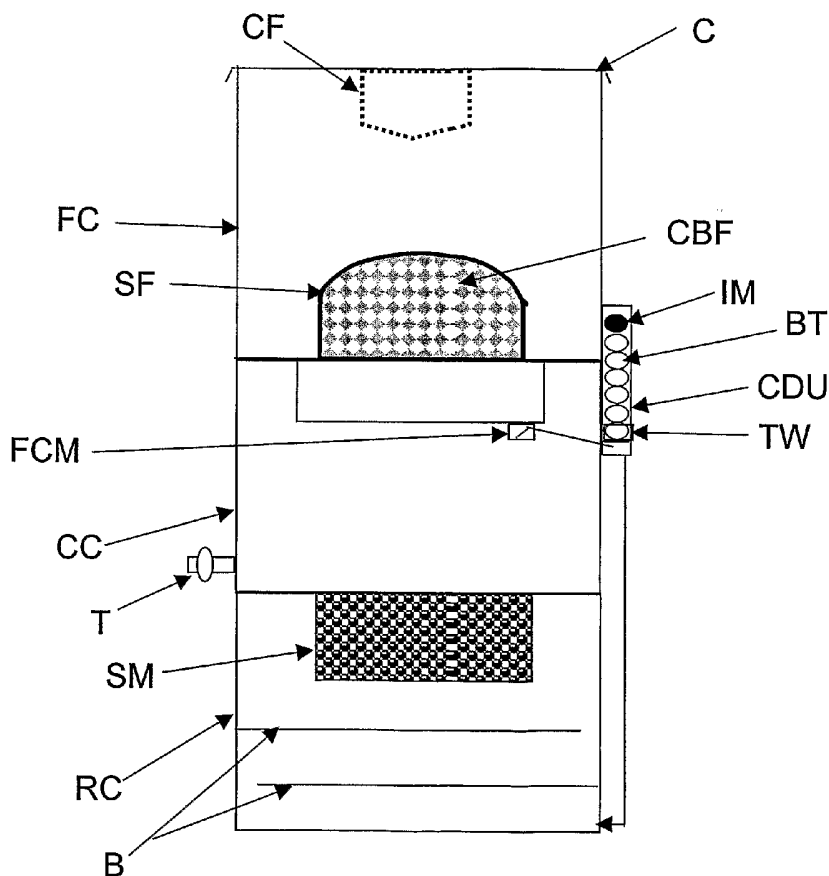

(57) Abstract: The invention concerns a gravity fed water purification system comprising: - a filtration unit adapted to separate particulate and soluble material from the input water, which unit is in fluid communication with - a chemical dispensing unit such that flow rate of water exiting the filtration unit is controlled by - a flow control means before the water encounters a biocide dispensed by the chemical dispensing unit, the water thereafter being retained in - a retention chamber for a predetermined period of time before exiting the water purification system through - a scavenger means adapted to separate the dispensed biocide from the exit water.

WO 2005/095284 A1



HINDUSTAN LEVER RESEARCH CENTRE, I.C.T.  
Link Road, Chakala, Andheri East, Mumbai 400 099 (IN).

**(72) Inventors; and**

**(75) Inventors/Applicants (for US only):** CHATTERJEE, Jaideep [IN/IN]; HINDUSTAN LEVER RESEARCH CENTRE, I.C.T. Link Road, Chakala, Andheri East, Mumbai 400 099 (IN). DAVE, Parthiv, Ripudaman [IN/IN]; HINDUSTAN LEVER RESEARCH CENTRE, I.C.T. Link Road, Chakala, Andheri East, Mumbai 400 099 (IN).

**(74) Agent:** DEKKER, Enno, E.J.; Unilever Intellectual Property Group, Olivier van Noortlaan 120, NL-3133 AT Vlaardingen (NL).

**(81) Designated States (unless otherwise indicated, for every kind of national protection available):** AE, AG, AL, AM, AT, AU, AZ, BA, BB, BG, BR, BW, BY, BZ, CA, CH, CN, CO, CR, CU, CZ, DE, DK, DM, DZ, EC, EE, EG, ES, FI, GB, GD, GE, GH, GM, HR, HU, ID, IL, IN, IS, JP, KE,

KG, KP, KR, KZ, LC, LK, LR, LS, LT, LU, LV, MA, MD, MG, MK, MN, MW, MX, MZ, NA, NI, NO, NZ, OM, PG, PH, PL, PT, RO, RU, SC, SD, SE, SG, SK, SL, SM, SY, TJ, TM, TN, TR, TT, TZ, UA, UG, US, UZ, VC, VN, YU, ZA, ZM, ZW.

**(84) Designated States (unless otherwise indicated, for every kind of regional protection available):** ARIPO (BW, GH, GM, KE, LS, MW, MZ, NA, SD, SL, SZ, TZ, UG, ZM, ZW), Eurasian (AM, AZ, BY, KG, KZ, MD, RU, TJ, TM), European (AT, BE, BG, CH, CY, CZ, DE, DK, EE, ES, FI, FR, GB, GR, HU, IE, IS, IT, LT, LU, MC, NL, PL, PT, RO, SE, SI, SK, TR), OAPI (BF, BJ, CF, CG, CI, CM, GA, GN, GQ, GW, ML, MR, NE, SN, TD, TG).

**Published:**

— with international search report

*For two-letter codes and other abbreviations, refer to the "Guidance Notes on Codes and Abbreviations" appearing at the beginning of each regular issue of the PCT Gazette.*

## **WATER PURIFICATION SYSTEM**

### **Technical field**

5 The present invention relates to a gravity fed water purification system which provides purified potable water of superior quality. The water purification system consistently provides high flow rates of potable water over a long period of time while ensuring the removal of harmful contaminants.

10

### **Background and prior art**

A large population of people in the world live in countries where there is a severe shortage of hygienic potable water. People have to depend directly on  
15 ground water sources like wells, ponds and rivers. Often these water sources are contaminated by sewage, industrial effluents and agricultural byproducts like pesticide residues.

It is known to have gravity fed water filters for domestic use such as carafe filter  
20 in which water enters the filter element through a series of small perforations at the wider top of a trapezoid shaped filter and flows through the filter to the narrower bottom in the process traversing through a porous bed of loose absorbents. Such filters have inherent limitations in achieving effective flow rates since the water is required to traverse a deep bed of absorbent particles  
25 and often choke after a small quantity of water has passed through. Moreover such filters do not effectively separate the harmful pathogens present in water.

WO9529878 (Recovery Engineering Inc. 1995), discloses a water purifying device, comprising a disinfecting unit comprising an iodinated resin unit and an activated charcoal unit. This unit has its limitations due to the high cost of iodinated resin units. Moreover the residual iodine present in water may be  
5 harmful to some people.

Hence there still a need to develop improved water purification systems that are inexpensive to use and are consistently more effective in producing healthy potable water at the desired rate while ensuring removal of all harmful  
10 contaminants including particulate matter and soluble material like noxious odour, pesticide residues and other organic matter and also harmful microorganisms like cyst, bacteria and virus. Also it is very important that all of the biocide chemicals used for killing the pathogenic microorganisms are removed by the system before the purified water is consumed by the people.  
15 More importantly, the system must provide the consistently high desired flow of purified water over long periods of time from a gravity head of a few centimeters. There is also a need felt for a water purification system that does not require frequent cleaning, replacement of parts or maintenance. The prior art does not provide for all of these desirable characteristics.

20

### **Objects of the invention**

It is thus an object of the present invention to provide a gravity fed water  
25 purification system that provides for clean potable water at a consistently high flow rate of water of about 100 to 200 ml/minute, over long periods of time wherein the flow rate does not change appreciably with the change in head of the input water.

It is another object of the invention to provide for a gravity fed water purification system that provides potable water that is free of contaminants like particulate matter and dissolved impurities like bad odour, pesticide residues and other organic matter and also harmful pathogens like cyst, bacteria and virus.

5

It is yet another object of the invention to provide for a gravity fed water purification system that does not require any external energy like electric power to run the unit.

10 Another object of the invention is to provide a gravity fed water purification system that does not require the use of expensive replacement parts and therefore provides for a low maintenance cost.

### 15 **Summary of the invention**

Thus the present invention provides a gravity fed water purification system comprising a filtration unit adapted to separate particulate and soluble material from the input water, which is in fluid communication with a chemical  
20 dispensing unit such that flow rate of water exiting the filtration unit is controlled by a flow control means before the water encounters a biocide dispensed by the chemical dispensing unit, the water thereafter being retained in a retention chamber for a predetermined period of time before exiting the water purification system through a scavenger means adapted to separate the dispensed biocide  
25 from the exit water.

### Detailed description of the invention

Thus the present invention provides for a gravity fed water purification system comprising

- 5 - a filtration unit adapted to separate particulate and soluble material from the input water, which is in fluid communication with
- a chemical dispensing unit such that flow rate of water exiting the filtration unit is controlled by
- a flow control means before the water encounters a biocide dispensed
- 10 by the chemical dispensing unit, the water thereafter being retained in
- a retention chamber for a predetermined period of time before exiting the water purification system through
- a scavenger means adapted to separate the dispensed biocide from the exit water.

15

It is preferred that the flow control means comprises a flow control reservoir of pre-selected dimensions adapted to discharge the required volume of water comprising at least one inlet means for entry of the water from the outlet of said filtration unit into the reservoir and at least one siphon discharge means

20 operatively connected to said flow control reservoir and adapted to control the flow rate of the water from said reservoir.

The filtration unit preferably comprises a carbon block filter medium. The carbon block filter medium comprises powder activated carbon (PAC) and a

25 binder which are well mixed and made into a block by pressure and heat treatment. The PAC is preferably selected carbon derived from bituminous coal, coconut shell or wood charcoal, or petroleum tar. Preferably, the PAC used

has a size uniformity coefficient of less than 2, or more preferably less than 1.5, a carbon tetrachloride number exceeding 50%, more preferably exceeding

30 60%.

Suitable carbon block filter media are those disclosed in GB2390987, more preferably that disclosed in our copending application 320/MUM/2004. The copending application describes a carbon block filter media for use in gravity fed  
5 filters comprising powder activated carbon (PAC) having a particle size such that 95 wt% of the particles pass through 50 mesh and not more than 12% passes through 200 mesh and a binder material having a Melt Flow Rate (MFR) of less than 5. Further preferred carbon block filter media have 55 to 80 wt % of the PAC particles in the particle size range of 100 to 200 mesh in the lower  
10 50 volume% of the carbon block .

By way of the above filtration unit it is possible to maintain a flow rate of water, with a water head of 75 mm, under gravity, of 100-300 ml/min., consistently over long time without compromising on the requirements of removal of  
15 particulate contaminants apart from chemical contaminants.

The filtration unit may be used along with other known filtration means such as sediment filter means, preferably, a washable or replaceable sediment filter for removing fine dust and other micro-particulates. The sediment filter can be a  
20 non-woven fabric, preferably a microporous fabric with a pore size suitable to retain particles of 3µm and above. Most preferably the water first passes the sediment filter before passing the carbon block filter medium.

The gravity fed water purification system of the invention comprises a flow  
25 control means that regulates the flow rate of water exiting the filtration unit. The flow regulation is preferably achieved using means that do not require input of external energy, for example electrical energy. The flow control means may include flow throttling means like stopcocks, valves, venturies or baffles. More preferably, the flow control means as described in our co-pending application  
30 927/MUM/2002 which comprises a combination of straight path and at least

one bend adapted for controlling the flow rate of water, may be used.

Particularly preferred flow control means for the purposes of the invention are those described in WO2004/074182. This latter flow control means comprises a flow control reservoir of pre-selected dimensions adapted to discharge the  
5 required volume of water comprising at least one inlet means for entry of the water from the outlet of said filtration unit into the reservoir and at least one siphon discharge means operatively connected to said flow control reservoir and adapted to control the flow rate of the water from said reservoir.

- 10 The rate of flow of water as described in the above co-pending application can be regulated to a high degree by way of selected dimensions of the control reservoir and selective embodiment of the siphon discharge means of a tubular member of pre-selected dimensions including diameter and shape, preferably an inverted tubular "U/ V" shaped member to facilitate the flow rate control.
- 15 The use of this preferred aspect of the flow control means ensures excellent regulation of the flow rate of the water irrespective of the flow rate of water exiting the filtration unit.

The water exiting the flow control means encounters a biocide dispensed by a  
20 chemical dispensing unit. The chemical dispensing unit is preferably a unit that dispenses the biocide without the use of external energy like electrical energy. It is possible that the water flows through the chemical dispensing unit, configured to deliver the desired concentration of the biocide into the water. The biocide in the chemical dispensing unit may be present in liquid form and  
25 be dispensed into the water in controlled amounts. Preferably, the biocide is present in solid form and leaches into the water at a controlled rate when the water contacts the surface of the solid. More preferably the solid is in the form of one or more tablets. When there are more than one tablet, it is preferred  
30 are placed stacked one on top of the other. The tablet leaches the biocide in to

the water in a controlled manner and any means to achieve this may be used. Preferably the chemical dispensing unit of the invention may comprise the chemical sanitization system disclosed in our co-pending application 926/MUM/2002. Preferably during the leaching the tablet slowly dissolves and a  
5 new tablet comes into contact with the water as the previous one is dissolved.

The chemical sanitizing system described in the above co-pending application comprises a sanitizing unit containing the chemical sanitizing agents and having opening at the bottom thereof, means for feeding in water to be sanitized  
10 having a nozzle like top selectively disposed adjacent thereunder and facing said opening at the bottom of said unit and said nozzle like top having a selective angular conical outer surface such as to favour regulated contact and delivery of said active sanitizing agent upon contact of the flowing stream of the water with the exposed sanitizing agent through said opening.

15

The chemical dispensing unit is preferably of cylindrical cross-section holding the biocide tablets stacked one over the other on a perforated disc or a non woven fabric. There is a water inlet centrally located under the biocide holder. Water enters through the inlet, touches the surface of the tablets and exits  
20 through the windows (openings) on the periphery of the holder.

It is preferred that the biocide is a chemical that delivers active chlorine to the water to ensure kill of the microorganisms. Any chlorine releasing biocide may be used including chlorinated trisodium phosphate, calcium hypochlorite, lithium  
25 hypochlorite, the various N-chlorinated compounds known in the art to release active chlorine such as sodium or potassium dichloroisocyanurate, trichlorocyanuric acid, , monochloramine, dichloramine, [(monotrichloro)-tetra(monopotassium dichloro)] pentaisocyanurate, 1,3-dichloro-5,5-dimethylidantone, Chloramine T, p-toluene-sulfodichloroamide,  
30 thrichloromelamine, N-chloramine, N-chlorosuccinimide, N,N'-

dichloroazodicarbonamide, N-chloroacetyl-urea, N,N-dichloroazodicarbonamide, N-chloroacetyl-urea, N,N-dichlorbiuril, chlorinated dicyandiamide.

- 5 In a preferred aspect of the invention the water purification system additionally comprises an indicator means that provides an indication when all of the available biocide tablets are consumed after a period of time. Preferably, the indicator means provides a visual indication of complete or nearly complete consumption of the biocide tablets. Any indicator means known in the art may
- 10 be used. It is particularly preferred that the indicator means includes a coloured tablet placed at the top of the stack of biocide tablets and a window transparent to light at the bottom of the chemical dispensing unit to enable visual inspection of the lowest most tablet. The coloured tablet may be inert., in which case it is highly stable in the environment of the biocide and water. When the biocide is
- 15 a chemical which releases chlorine, the inert tablet is made of a material which is highly inert to the oxidative properties of chlorine. Alternatively the inert tablet is coated with a material preferably a polymeric material which is highly inert to chlorine.
- 20 In a further preferred aspect of the invention the water purification system additionally comprises a water shutoff means that ensures that no more water flows through the flow control means if the biocide is used up. The water shut off means preferably comprises the said inert tablet. That tablet may be made of magnetic material, preferably iron or nickel, suitably coated with a coating
- 25 inert to the biocide and a counter magnet may be placed at the bottom of the chemical dispensing unit, such that when all of the biocide is used up, the two magnetic pieces come close enough to attract each other thereby effecting a valve means that ensures shut off of the water exiting the control means.

After passing the biocide dispenser, the water containing the biocide is held in the system in a retention chamber for a predetermined period of time. Not wishing to be bound by theory, it is believed that holding the water containing the biocide for this period of time ensures that all of the pathogenic

5 microorganisms like bacteria and viruses are killed. It is preferable that the water is held for a time is in the range 30 to 300 minutes and more preferably 60-180 minutes in the retention chamber. Any means to hold the water for this period of time in the water purification system may be used. Highly suitable means are illustrated in WO2004/000732. An alternative preferred means to

10 ensure that the water is held in the retention chamber for this period of time is by providing for downcomer pipes leading the water from the base of the chemical dispensing unit to the retention chamber which ensure a near laminar flow of water in the retention chamber which is separated into two or more horizontal sections by baffle plates. The distance between the inlet of water in

15 to the retention chamber and the outlet of water out of each section of the retention chamber is maximized by providing entry and exit points at farthest distances from each other. This long distance travelled by the water combined with the near laminar flow of water in the retention chamber ensures the desired holding time.

20

The water exiting the retention chamber passes through a scavenging means before exiting the water purification system. The scavenging means separates the dispersed biocide from water. The scavenger means is preferably bacteriostatic activated carbon.

25

Although the water may flow through the scavenger means in the downward direction or in the upward direction, it is preferred that the water flows through the scavenger means in the upward direction. Various embodiments may be envisaged for such flow including those described in WO2004/014803.

30

According to a further preferred aspect of the invention there is provided a gravity fed water purification device comprising

- a feed chamber having a coarse filter through which water to be purified is fed in to the feed chamber
- 5 - a carbon block filter media and a correspondingly shaped sediment filter of non woven fabric which is replaceable/washable adapted to separate particulate and soluble material from the input water,
- which is in fluid communication with a chemical dispensing unit comprising an indicator means such that flow rate of water exiting the  
10 filtration unit is controlled by
- a flow control means comprising a flow control reservoir and a siphon means before the water encounters a biocide dispensed by the chemical dispensing unit,
- the water thereafter being retained in a retention chamber for a  
15 predetermined period of time before exiting the water purification system through
- an upflow scavenger means adapted to separate the dispensed biocide from the exit water.

20 The invention will now be illustrated with help a specific non-limiting example of a water purification system according to the invention in Figure 1.

### Example

25

Figure 1 is an embodiment of the water purification system according to the invention. The system has a feed chamber (FC) to which water to be purified is added through coarse filter (FC) which is adapted to trap big particles. The feed vessel is of a small height of a maximum of 20 cm which provides for a low  
30 gravity head for filtration of the water through the carbon block filter medium

(CBF). A sediment filter (SF) made of non-woven fabric and corresponding to the shape of the carbon block filter media (CBF) is placed on it. The sediment filter removes particulates in the size range of 3 to 6  $\mu\text{m}$ . The carbon block filter separates particle finer than 3  $\mu\text{m}$ , dissolved organics and pesticides. It also  
5 filters chlorine resistant cysts. The water from the carbon block filter flows down by gravity into the flow control means (FCM) comprising a control reservoir and a siphon discharge means to effectively control the flow rate of water before encountering the biocide. The flow control means ensures that the flow rate is controlled to a very narrow range irrespective of the head of  
10 water in the feed chamber (FC). The biocide is dispensed into the water exiting the flow control means (FCM) from the chemical dispensing unit (CDU). The chemical dispensing unit has a stack of biocide tablets (BT) and an indicator means (IM) comprising a coloured inert tablet. A transparent window (TM) is provided at the base of the chemical dispensing unit (CDU) through which the  
15 indicating means (IM) can be viewed once all the biocide tablets are used up. The water containing the biocide then enters the retention chamber (RC) where it is held for a predetermined amount of time in which all the viruses and bacteria are killed. Baffles (B) are provided in the retention chamber (RC) to ensure a selected path for the flow of water and thereby the desired retention  
20 time. The water then traverses in the up flow direction through the scavenger means (SM) which separates the biocide from the water. The water is then collected in a collection chamber (CC). The purified water free of all contaminants can be dispensed through the tap (T).

25 It is thus possible by way of the present invention to provide for a simple and cost effective gravity fed water purification system that provides for clean potable water free of all contaminants including particulates, microorganisms and soluble matter including pesticide residues at the desired high flow rate consistently over long period of time.

## Claims

1. A gravity fed water purification system comprising
  - a filtration unit adapted to separate particulate and soluble material from the input water, which is in fluid communication with
  - a chemical dispensing unit such that flow rate of water exiting the filtration unit is controlled by
  - a flow control means before the water encounters a biocide dispensed by the chemical dispensing unit, the water thereafter being retained in
  - a retention chamber for a predetermined period of time before exiting the water purification system through
  - a scavenger means adapted to separate the dispensed biocide from the exit water.
  
2. A water purification system as claimed in claim 1 wherein the flow control means comprises:
  - a flow control reservoir of pre-selected dimensions adapted to discharge the required volume of water, the reservoir comprising at least one inlet means for entry of the water from the outlet of said filtration unit into the reservoir and
  - at least one siphon discharge means operatively connected to said flow control reservoir and adapted to control the flow rate of the water from said reservoir.
  
3. A water purification system as claimed in claim 1 or 2 wherein the filtration unit comprises a carbon block filter medium.

4. A water purification system as claimed in claim 3 wherein the carbon block filter medium comprises powder activated carbon (PAC) and a binder material which are well mixed and made into a block by pressure and heat treatment.
5. A water purification system as claimed in any preceding claim wherein a flow rate of water of 100-300 ml/minute is maintained under a head of water of about 75 mm.
6. A water purification system as claimed in any preceding claim wherein the filtration unit additionally comprises a sediment filter.
7. A water purification system as claimed in claim 6 wherein the sediment filter is a non woven fabric with a pore size suitable to retain particles with a particle size of 3  $\mu\text{m}$  and higher.
8. A water purification system as claimed in any preceding claim wherein the biocide is present in the form of one or more tablets.
9. A water purification system as claimed in claim 8 wherein the tablets are stacked one on top of the other.
10. A water purification system as claimed in any preceding claim wherein the biocide is a chemical that delivers active chlorine to the water.
11. A water purification system as claimed in any preceding claim additionally comprising an indicator means that provides an indication when all of the available biocide are consumed after a period of time.

12. A water purification system as claimed in claim 11 wherein the indicator means provides a visual indication.
13. A water purification system as claimed in claim 12 wherein the indicator means includes a coloured inert tablet placed at the top of the stack of biocide tablets and a window transparent to light at the bottom of the chemical dispensing unit to enable visual inspection of the lowest tablet.
14. A water purification system as claimed in any preceding claim additionally including a water shutoff means that ensures that no more water flows through the flow control means if the biocide is used up.
15. A water purification system as claimed in claim 14 wherein the water shutoff means comprises the said inert tablet made of magnetic material suitably coated with a coating inert to the biocide and a counter magnet placed at the bottom of the chemical dispensing unit, such that when all of the biocide is used up, the two magnetic pieces come close enough to attract each other thereby effecting a valve means that ensures shut off of the water exiting the control means.
16. A water purification system as claimed in any preceding claim wherein the water is held for an average time in the range 30 to 300 minutes in the retention chamber.
17. A water purification system as claimed in claim 16 wherein the water is held for an average time in the range of 60 to 80 minutes in the retention chamber.

18. A water purification system as claimed in any preceding claim wherein the retention chamber is separated into two or more horizontal sections by baffle plates.
19. A water purification system as claimed in any preceding claim wherein the scavenger means comprises bacteriostatic activated carbon.
20. A water purification system as claimed in any preceding claim wherein the water flows through the scavenger means in the upward direction.
21. A gravity fed water purification device comprising
  - a feed chamber having a coarse filter through which water to be purified is fed in to the feed chamber
  - a carbon block filter medium and a correspondingly shaped sediment filter of non woven fabric which is replaceable/washable adapted to separate particulate and soluble material from the input water,
  - which is in fluid communication with a chemical dispensing unit comprising an indicator means such that flow rate of water exiting the filtration unit is controlled by
  - a flow control means comprising a flow control reservoir and a siphon means before the water encounters a biocide dispensed by the chemical dispensing unit,
  - the water thereafter being retained in a retention chamber for a predetermined period of time before exiting the water purification system through
  - an upflow scavenger means adapted to separate the dispensed biocide from the exit water.

Figure 1

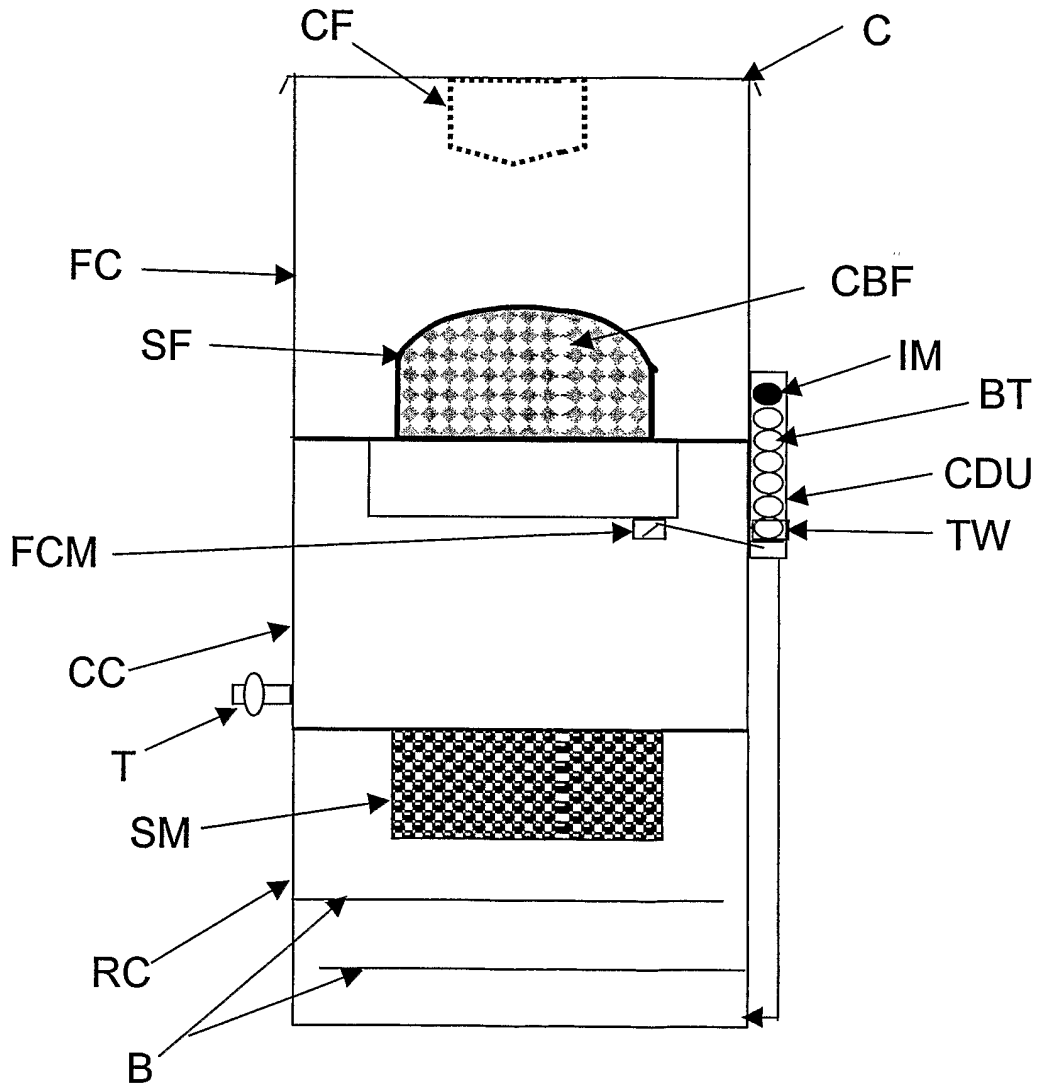

**INTERNATIONAL SEARCH REPORT**

International Application No  
PCT/EP2005/002254

**A. CLASSIFICATION OF SUBJECT MATTER**  
IPC 7 C02F1/50 C02F9/00

According to International Patent Classification (IPC) or to both national classification and IPC

**B. FIELDS SEARCHED**

Minimum documentation searched (classification system followed by classification symbols)  
IPC 7 C02F B01D A61L

Documentation searched other than minimum documentation to the extent that such documents are included in the fields searched

Electronic data base consulted during the international search (name of data base and, where practical, search terms used)  
EPO-Internal, WPI Data, PAJ, COMPENDEX, INSPEC, BIOSIS

<b>C. DOCUMENTS CONSIDERED TO BE RELEVANT</b>		
Category °	Citation of document, with indication, where appropriate, of the relevant passages	Relevant to claim No.
Y	WO 2004/000732 A (UNILEVER PLC; UNILEVER NV; HINDUSTAN LEVER LIMITED) 31 December 2003 (2003-12-31) cited in the application page 4, line 17 - line 21 page 5, line 19 - page 9, line 10; claims 1-4; figures 1-3	1-21
Y	US 6 281 802 B1 (VENABLE ROBERT T ET AL) 28 August 2001 (2001-08-28) column 3, line 40 - column 4, line 53 column 5, line 11 - line 24; claims 1-10; figures 1,3,4	1-3,5-21
	----- -/-- -----	

Further documents are listed in the continuation of box C.       Patent family members are listed in annex.

° Special categories of cited documents :

"A" document defining the general state of the art which is not considered to be of particular relevance	"T" later document published after the international filing date or priority date and not in conflict with the application but cited to understand the principle or theory underlying the invention
"E" earlier document but published on or after the international filing date	"X" document of particular relevance; the claimed invention cannot be considered novel or cannot be considered to involve an inventive step when the document is taken alone
"L" document which may throw doubts on priority claim(s) or which is cited to establish the publication date of another citation or other special reason (as specified)	"Y" document of particular relevance; the claimed invention cannot be considered to involve an inventive step when the document is combined with one or more other such documents, such combination being obvious to a person skilled in the art.
"O" document referring to an oral disclosure, use, exhibition or other means	"&" document member of the same patent family
"P" document published prior to the international filing date but later than the priority date claimed	

Date of the actual completion of the international search <b>13 June 2005</b>	Date of mailing of the international search report <b>28/06/2005</b>
--	---

Name and mailing address of the ISA European Patent Office, P.B. 5818 Patentlaan 2 NL - 2280 HV Rijswijk Tel. (+31-70) 340-2040, Tx. 31 651 epo nl, Fax: (+31-70) 340-3016	Authorized officer <b>Glod, G</b>
--	--------------------------------------

## INTERNATIONAL SEARCH REPORT

International Application No  
PCT/EP2005/002254

C.(Continuation) DOCUMENTS CONSIDERED TO BE RELEVANT		
Category °	Citation of document, with indication, where appropriate, of the relevant passages	Relevant to claim No.
Y	WO 00/18810 A (TICONA GMBH; HAFTKA, STANISLAW; EHLERS, JENS; WANG, LOUIS; BARTH, CHRI) 6 April 2000 (2000-04-06) page 5, line 5 - page 6, line 3; claims 1-10	4
A	US 6 309 551 B1 (SUCHECKI, JR. RONALD J ET AL) 30 October 2001 (2001-10-30) column 6, line 5 - column 7, line 35; figure 6	1,8-15, 21
P,X	WO 2004/074182 A (UNILEVER PLC; UNILEVER NV; HINDUSTAN LEVER LIMITED; DAVE, PARTHIV, RIP) 2 September 2004 (2004-09-02) page 8, line 25 - page 11; claims 1-6; figures 1,2	1-3,5,8, 10,16, 17,19,20

# INTERNATIONAL SEARCH REPORT

Information on patent family members

International Application No

PCT/EP2005/002254

Patent document cited in search report	Publication date	Patent family member(s)	Publication date
WO 2004000732 A	31-12-2003	AU 2003240707 A1 BR 0311779 A WO 2004000732 A1	06-01-2004 08-03-2005 31-12-2003
US 6281802 B1	28-08-2001	NONE	
WO 0018810 A	06-04-2000	DE 19844167 A1 AU 6087199 A BR 9913931 A CA 2344860 A1 CN 1319108 A DE 59911453 D1 WO 0018810 A2 EP 1117706 A2 JP 2002525400 T US 6770736 B1 US 2005004299 A1	06-04-2000 17-04-2000 23-10-2001 06-04-2000 24-10-2001 17-02-2005 06-04-2000 25-07-2001 13-08-2002 03-08-2004 06-01-2005
US 6309551 B1	30-10-2001	US 6183631 B1	06-02-2001
WO 2004074182 A	02-09-2004	WO 2004074182 A2	02-09-2004