

⑫

EUROPEAN PATENT SPECIFICATION

⑬ Date of publication of patent specification: **12.03.86**

⑭ Int. Cl.⁴: **C 25 C 7/02, C 25 C 7/08,**
C 25 C 7/00

⑮ Application number: **81201392.8**

⑯ Date of filing: **23.12.81**

⑰ **Electrode edge protector, electrode provided with such protector.**

⑱ Date of publication of application:
29.06.83 Bulletin 83/26

⑲ Proprietor: **Berger, Peter**
The Old Vicarage Gringley-on-the-Hill
Doncaster S. Yorkshire DN10 4RF (GB)

⑳ Publication of the grant of the patent:
12.03.86 Bulletin 86/11

㉑ Inventor: **Berger, Peter**
The Old Vicarage Gringley-on-the-Hill
Doncaster S. Yorkshire DN10 4RF (GB)

㉒ Designated Contracting States:
AT BE DE SE

㉒ Representative: **Long, Edward Anthony et al**
Hulse & Co. Cavendish Buildings West Street
Sheffield S1 1ZZ (GB)

㉓ References cited:
BE-A- 746 708
DE-A-1 533 443
US-A-3 798 151
US-A-3 830 710
US-A-4 186 074

**The file contains technical information
submitted after the application was filed and
not included in this specification**

Note: Within nine months from the publication of the mention of the grant of the European patent, any person may give notice to the European Patent Office of opposition to the European patent granted. Notice of opposition shall be filed in a written reasoned statement. It shall not be deemed to have been filed until the opposition fee has been paid. (Art. 99(1) European patent convention).

EP 0 082 221 B1

Description

This invention relates to an edge protector for electrodes, e.g. cathode matrix plates as are used in the electrodeposition of metal and, more particularly, in the production of electrodeposits upon, and their subsequent integral detachment from, so-called master-cathodes or matrices in the form of flat plates or sheets, as practised in such processes as electroforming, electrolytic extraction ("electrowinning") and refining of metals. Though by no means confined thereto, the invention is especially relevant to the production of so-called "starting sheets" in electro-winning and electro-refining of such metals as copper, zinc, nickel and cobalt. Thus, for example, a copper starting sheet serves as the cathode in the production of electrolytic copper, forming the nucleus of the electrodeposited end-product. This starting sheet is itself produced by electrodeposition onto a matrix plate from which it is detached; the matrix is then re-used again and again, for as many cycles as possible. If made of titanium (as often is the case), the matrix is expensive so that it is important to avoid its being damaged during the stripping of the electrodeposited starting sheet. For economic reasons, the stripping process needs to be carried out quickly, so as to speed the recycling of the matrices. When the electrodeposit is not readily detachable, the process is slowed down, at best, but may result in large numbers of starting sheets being torn or deformed—and, at worst, the valuable matrix may itself be damaged and rendered unserviceable in the stripping process.

A typical matrix plate may be 3mm (1/8") thick, measuring (in its immersed portion) some 1m x 1m (ca. 40" x 40") so that each side produces a starting sheet of some 1m² (ca. 11ft²) in area. It will be seen, therefore, that the stripping process is rendered more difficult when the electrodeposit extends over the vertical edges of the matrix plate, so that a continuous layer surrounds the matrix in the horizontal plane; the bottom edge creates no such problems by itself, if the vertical edges are kept bare, the deposit joining back and front layers across the horizontal bottom edge is simply trimmed off to produce the two separate starting sheets; it is usual practice to provide a 'V'-notched groove along the 3mm wide downward facing base of the matrix plate, and to operate with anodes which are significantly shorter in length than the (matrix) cathodes. The electrodeposit reaching the apex of the inverted 'V'-notch is, therefore, extremely thin and readily fractures in a straight line along the apex of the groove when the deposited starting sheets on front and back of the matrix plate are stripped therefrom and folded away from the plate, using the apex-line of the groove as the folding axis. Protection of the grooved base of the matrix plate is required only in special cases (e.g. when there would be adhesion of the deposit within the groove in processes using other than inherently

superficially "passive" matrix plates—i.e., other than, e.g. titanium).

A number of so-called "edge protectors" have been proposed to prevent metal deposition at the vertical edges of the matrix plate; but none of these devices has remained effective for more than but a relatively few cycles, and partial break-down of such a protector can create additional hazards of damage to electrodeposit and/or matrix during the stripping process. Moreover, waste material from "lace" edges of the deposit requires re-melting which is wasteful of energy and inconvenient. Conventional "stop-off" coatings are porous (especially at the relatively sharp edge of the titanium plate, where such dipped or painted coatings are thinnest), and if thickly applied, their adhesion is inadequate. Rubber and/or plastic "edge-strips" as hitherto proposed all rely upon the intrinsic elasticity or "springiness" of the material to provide an effective seal onto the matrix plate to prevent the electrolyte from penetrating; these edge-strips are of "U"-profile, resembling edge-trim on a motor-car door surround etc; one type proposed is made up of twin 'U' sections, a soft inner one (presumably to overcome surface irregularities on the rolled titanium sheet) with a stiff outer 'U' intended to act as a clamp to ensure sealing; in all these cases, the effect of the electrolyte temperature of some 60°C or more, and applied over prolonged periods has resulted in break-down; the materials used softened and/or their elasticity was progressively reduced, and this, added to the considerable differential in the respective coefficients of thermal expansion of the plastic and the titanium, resulted in break-down of the seal. The electrolyte is very searching, and metal "seeds" are deposited wherever seepage occurs; these seeds grow apace, and total break-down of the edge-insulation becomes inevitable. Moreover, there was the added hazard of the operator's knife slipping during the stripping process, dislodging the edge-strip. This hazard is a drawback also when adhesive tape is used for edge-insulation. The adhesive also loses its efficiency, but there are reports that polyester-based adhesive tape can remain effective for some 20—30 cycles. In large operations, however, it would not be economical to re-apply adhesive tape after only 20—30 cycles. Edge protection is especially important in processes such as the recently developed "ISA Process" (described at the 110th A.I.M.E. Annual Meeting in Chicago Ill., U.S.A. on February 23, 1981) where starting sheets are dispensed with, and detachable thick copper cathodes (weighing 45kg each, 90kg per pair) are deposited onto nickel-plated stainless steel matrices. Here, vertical edge-strips of extruded "Cycloy 800"® plastic are fixed to the matrices by means of plastic pins passing through holes drilled in the matrix, and sealing is effected by means of a sacrificial layer of high melting point wax, which is also applied to the base of the matrix plate: this waxing process is carried out for each electro-deposition cycle, the process is

laborious and requires special machines both for the application and the recovery of the wax. (ref: "The use of permanent stainless steel cathodes at Copper Refineries Pty. Ltd., Townsville" by I. J. Perry, J. C. Jenkins and Y. Okamoto: Trans.AIME conference 23/Feb/1981, Chicago, Ill.).

Furthermore, U.S. Patent 3798151 discloses a starter blank for producing a starter sheet for use in an electrolytic metal-refining process having a flexible, resilient, U-shaped frame placed upon and around its peripheral edges. To facilitate insertion of the starter blank within the frame member, as well as the stripping of the starter sheet from the starter blank, a wedge is associated with the frame member. To insert the starter blank within the frame member, the wedge is removed from the frame member and the notched portions of the frame member which house the wedge member are squeezed together simulating a lever-and-fulcrum action. Such action consequently spreads the U-shaped portion of the frame member, hereby facilitating easy insertion of the starter blank within the frame. To lock the blank and frame together, the wedges are subsequently inserted within the notched housing portions, thereby simulating a shrink-fitting operation. When the plate is utilized as a cathode, the bottom portion of the frame is removed, and in lieu thereof, the bottom edge portion of the plate is provided with an inwardly extending V-shaped groove or notch, such configuration aiding the stripping process for the cathode similar to that performed by the removed frame portion relative to the starter blank.

According to the present invention there is provided an edge protector for electrodes comprising first and second elongate elements both elements being of a rigid material which is firstly electrically insulating and secondly is chemically and thermally stable in the intended process environment of the electrode; the first element having a generally 'H'-shaped cross-section so as to define open slots on opposite sides thereof, one slot profiled generally as a circular segment greater than a semi-circle and defined between a pair of outer jaws and the other slot defined between a pair of inner jaws, with an edge of an electrode being insertable into and locatable within the inner jaws; and the second element being constituted by a member of circular cross-section so dimensioned and shaped for interference snap fitting engagement with the outer jaws, whereby the outer jaws are forced further apart with the result that the outer jaws endeavour to close the inner jaws which are levered towards one another, thereby to exert a uniform pressure upon the edge of the electrode when located within the inner jaws, to form a seal to prevent electrolyte from wetting the edge of the electrode located within the inner jaws.

Thus, the edge protector of the present invention, unlike the aforementioned prior art proposals operates without recourse to the "springiness" of its material of construction, nor to the use of adhesives or painted-on layers—

other than for the purpose of compensating for surface irregularities as in the manner of a gasket—and its efficiency is unimpaired by the effects of thermal expansion; a number of materials which need not be identical for both elements may be utilised for its construction, and the type selected must, of course, remain unaffected chemically and thermally, by the process environment. The principle of operation is simple leverage which not only produces but sustains the necessary forces to maintain efficiency and resistance to dislocation, thus overcoming the shortcomings of existing devices as described in the foregoing. It will be realised that the said "H" configuration is in effect two "levers" (viz., the verticals of the "H"), with the fulcrum-plane represented by the horizontal cross-bar of the "H".

The two elongate elements of the edge protector may be of substantially equal length as appropriate for the size of the electrode concerned, and made of rigid insulating material, e.g., polypropylene. Alternatively, the second element may comprise a multiplicity of elongate pieces, the sum total of their combined lengths being substantially equal to the length of the first element of the edge protector.

The inner jaws may be so proportioned as to accept the edge of the electrode, inserted therein to a depth of (say) 8—10mm, the gap-width being just adequate to accommodate the thickness of the electrode, a so-called friction fit.

A rubber mallet may be used to force the second element(s) into the outer jaws. Furthermore, the second element may be of a material having a greater coefficient of thermal expansion than the material of the first element whereby the leverage action on the inner jaws is enhanced, if as is often the case, the electrode matrix is, in use, employed at elevated temperatures.

The invention also includes an electrode, of either polarity, e.g., a cathode matrix plate provided with edge protectors as defined above.

Where the electrodes "as rolled" surface has irregularities, the edge may, with advantage, be gasketed, e.g., by a suitable adhesive tape, such as polyester tape with thermosetting adhesive, applied to the portion of the electrode at and adjacent to the edge which is to be subsequently inserted into the inner jaws.

It is a further advantage that this edge protector—by itself, or serving as a structural support for attachment of supplementary devices—may be utilised to facilitate precise location of an electrode in the form of a cathode within the cell and/or relative to the anode, both in precision plating processes and for the purpose of preventing accidental short-circuits. Moreover, the edge protector may also be utilised with (insoluble) anode-plates, providing a convenient support for the attachment of e.g., anode-shields, bipolar or auxiliary electrodes etc. Although primarily intended for use attached to the vertical immersed edge of cathode matrix plate, the edge protector is equally suitable for attachment to the

plate's horizontal bottom edge when this is required. The two elongate elements of the edge protector may have such longitudinal dimensions as to protrude beyond the or the immersed length breadth of the electrode to which edge protectors are fitted. A piece of compressible and elastic or springy material such as nitrile "rubber" or neoprene ca. 3.5mm thick and some 9mm square may be entrapped within the protruding inner jaws so as to be in close contact with the 3mm (1/8") wide bare or taped bottom edge of the electrode within the inner jaws to prevent metal deposition on that portion (if bare) or to maintain close adhesion thereto of tape, if tape is employed as aforesaid. The said protrusions may serve for the additional purposes of locating an electrode plate in a cell and/or maintaining inter electrode distance therein and/or act as structural supports serving the said and/or other purposes, and the said protrusions also protect the bottom edge of the electrode plate when this has to be stood upright on the floor outside the cell during repairs or maintenance to equipment such as conveyors etc. The protruding ends of these vertical edge protectors of an electrode plate may also be interconnected by means of a member passing below the horizontal base of the plate. The said connecting member may be so designed and constructed as to serve any of the additional purposes as already referred to, and/or to protect the plate's horizontal bottom edge or (merely) its downward-facing base.

Depending upon the intended purpose of the said member, it may be attached to the vertical protrusions by means of permanent fixture, or it may be hinged at one end and detachably fastened at the other end, or it may be attached in such a manner as to be readily detachable from the vertical protrusions when required. Fixing methods—depending upon the member's shape in profile, etc.—include, e.g. mitred joints which may be welded, or gusseted and pinned or bolted, or clamping the ends of the said member within the inner jaws of the protrusions of the vertical edge protectors. In those special cases (usually confined to electroforming and/or precision plating) where it is necessary to protect all four edges of a plate, the latter may be inserted into a "U" frame formed of two vertical and one horizontal edge protector as hereinbefore described with mitred and welded joints at the corners of the base of the 'U'. A fourth edge protector is clamped onto the top edge of the plate—usually allowing a gap for attachment of the electrical conductor thereto. The said protrusions of vertical edge protectors fitted to an electrode plate may thus readily be used in a number of different ways to provide anchor-points for attachment of protectors of one or both horizontal edges of the plate.

The invention will now be described in greater detail, by way of example, with reference to the accompanying drawings, in which:—

Figure 1 is a side elevation of an electrode in accordance with one aspect of the invention

provided with edge protectors in accordance with another aspect of the invention and immersed in a cell;

Figure 2 is an enlarged section on the line II—II of Figure 1;

Figure 3 is an enlarged view in the direction of arrow III of Figure 1;

Figure 4 is a part section on the line IV—IV of Figure 3; and

Figure 5 corresponds to Figure 3 but illustrates the manner of assembly.

In the drawings, an electrode (1) in the form of a cathode matrix plate is illustrated immersed in electrolyte the surface of which is indicated at 2, the plate being generally rectangular and provided, at an upper edge 3 above the electrode surface 2 with a plurality of electrical conductors 4 leading to an electrode bar (not shown) of the cell. The plate also has a bottom edge 5 illustrated as horizontal and opposed edges 6, which are illustrated as vertical.

As can be seen from Figure 1, each vertical edge 6 is provided with an edge protector 7 which extends from above the electrolyte surface 2, to below the bottom edge 5. Considering Figure 2, each edge protector 7 can be seen to comprise a first elongate element 8 and a second elongate element 9, both of electrically insulating material, e.g., polypropylene. The first element 8 is "H"-shaped to provide a pair of inner jaws 10 defining a generally parallel sided slot 11 and a pair of outer jaws 12 defining a generally semi-circular slot 13. Before insertion into the slot 11, the edges 6 of the matrix plate are provided with a gasket 14 of polyester tape having a thermosetting adhesive to counter any surface irregularities in the edge 6, the slot 11 being of such a width that the edge 6 and its gasket 14 may be pressed as an interference fit into the slot 11 and be retained there by friction, and this situation has been attained in Figure 5. The second element 9 is of circular section and as indicated in Figure 5, is positioned over the slot 13 and tapped into its fully engaged position shown in Figure 2 by a rubber mallet 15 or similar tool. The effect of inserting the second element 9 is to force the outer jaws 12 further apart with the result that the inner jaws 10 are levered towards one another thereby exerting greater pressure upon the gasket 14, so that in service, an effective seal is formed by the inner jaws 10, to prevent electrolyte from wetting the edges 6. Although the first element 8 is one piece, the second element can consist of a plurality of individual pieces.

Figure 4 details the protrusion of an edge protector 7 below the bottom edge 5, the protrusions serving, e.g. as legs and/or for location purposes of the matrix plate within a cell and/or to protect the bottom edge 5 when the matrix plate is stood upright after removal from a cell. The protrusions are provided with a piece of nitrile rubber 16 secured between the inner jaws 10, to maintain adhesion of the tape 14 to the base of the matrix plate.

Claims

1. An edge protector for electrodes comprising first and second elongate elements (8, 9) both elements (8, 9) being of a rigid material which is firstly electrically insulating and secondly is chemically and thermally stable in the intended process environment of the electrode; the first element (8) having a generally 'H'-shaped cross-section so as to define open slots (11, 13) on opposite sides thereof, one slot (13) profiled generally as a circular segment greater than a semi-circle and defined between a pair of outer jaws (12) and the other slot (11) defined between a pair of inner jaws (10), with an edge (6) of an electrode (1) being insertable into and locatable within the inner jaws (10); and the second element (9) being constituted by a member of circular cross-section so dimensioned and shaped for interference snap fitting engagement with the outer jaws (12), whereby the outer jaws (12) are forced further apart with the result that the outer jaws (12) endeavour to close the inner jaws (10) which are levered towards one another, thereby to exert a uniform pressure upon the edge (6) of the electrode (1) when located within the inner jaws (10), to form a seal to prevent electrolyte (2) from wetting the edge (6) of the electrode located within the inner jaws (10).

2. An edge protector as claimed in Claim 1, wherein both the first and second elongate elements (8, 9) are of substantially equal length and made of one single piece of rigid insulating material.

3. An edge protector as claimed in Claim 1, wherein the second element (9) comprises a multiplicity of elongate pieces, the sum total of their combined lengths being substantially equal to the length of the first element (8).

4. An edge protector as claimed in Claim 2 or 3, wherein the insulating material is polypropylene.

5. An edge protector as claimed in any preceding Claim, wherein the inner jaws (10) are so proportioned as to accept the edge (6) of the electrode (1) as a so-called friction fit.

6. An edge protector as claimed in any preceding Claim, wherein the second element (9) is of a material having a greater coefficient of thermal expansion than the material of the first element (8) whereby the leverage action on the inner jaws is enhanced, at elevated temperatures.

7. An electrode provided with at least one edge protector as defined in any preceding Claim.

8. An electrode as claimed in Claim 7 wherein the edges (6) to receive the edge protectors (7) are gasketed.

9. An electrode as claimed in Claim 8, wherein gasketing is effected by adhesive tape applied to the portion of the electrode (1) at and adjacent to the edge (6) which is to be subsequently inserted into the inner jaws (10).

10. An electrode as claimed in Claim 9, wherein the adhesive tape is a polyester tape with thermosetting adhesive.

11. An electrode as claimed in any one of

Claims 7 to 10, provided with edge protectors (7) along edges (6) which, at least in use, will be vertical, and also along a horizontal edge.

12. An electrode as claimed in any one of Claims 7 to 11, wherein at least one edge protector (7) has such longitudinal dimensions, as to protrude beyond the length of breadth of the electrode (1).

13. An electrode as claimed in Claim 12, wherein a piece of compressible and elastic or springy insulating material (16) is entrapped within the protruding inner jaws (10) so as to be in close contact with that portion of the surface profile of the electrode (1) which lies within the inner jaws (10) and in a plane normal thereto at which the protrusion commences.

14. An electrode as claimed in Claim 12 or Claim 13, wherein the protruding portion of an edge protector (7) is utilised for the purpose of structurally and/or mechanically supporting and/or locating any device, whether or not affixed or attached thereto, which is an accessory or is in any way related to the electrolytic process in which the electrode (1) is to be employed.

15. A cathodic matrix plate provided with at least one edge protector as defined in any one of Claims 1 to 14.

Patentansprüche

1. Zweiteilige Elektrodenkantenschutzvorrichtung, umfassend: Klemmschiene (8) und Spreizstange (9) je gefertigt aus verformungs- fest-steifem Isolierhartstoff welcher außerdem in den jeweils für die Elektrode (1) zutreffenden, verfahrens-bedingten chemischen und thermischen Verhältnissen durchwegs beständig ist; die Klemmschiene (8) ist im Profil wesentlich 'H'- förmig gestaltet, mit zwei zueinander parallel gegenüberliegenden, entlangverlaufenden und nach außen hin offenen Nuten (11, 13): die eine Nut (13) mit der Hohlprofilform eines Kreisabschnitts-jedoch größer als ein Halbkreis-verläuft binnen zwei Außenbacken (12), die andere Nut (11) verläuft zwischen zwei Innenbacken (10) und ist derartig vorgesehen, daß eine dort einfügbare Elektrodenkante (6) binnen der beiden Innenbacken (10) fixierbar ist; das Rundprofil der Spreizstange (9) ist in seiner Form und Durchmessergröße gekennzeichnet dadurch, daß die Spreizstange (9) in die binnen der beiden Außenbacken (12) entlangverlaufenden Nut (13) einschnappbar ist und dort als Preßpassung einrastet, wodurch die beiden Außenbacken (12) auseinandergespreizt werden und infolgedessen eine Hebelung auf die beiden Innenbacken (10) bewirken und diese zu schließen suchen, so daß die derartig enger-aneinandergehebelten Innenbacken (10) auf eine dazwischenfixierte Elektrodenkante (6) einen gleichmäßigen Druck ausüben und diese fest eingeklemmt und wirksam abgedichtet wird und im Gebrauch unbenetzt vom Elektrolyten (2) verbleibt.

2. Zweiteilige Elektrodenkantenschutzvorrichtung nach Anspruch 1, bei welcher beide Bestand-

teile (8, 9) im wesentlichen gleichlang, und je aus einem einzelnen stück verformungsfest-steifen Isolierhartstoff gefertigt sind.

3. Zweiteilige Elektrodenkantenschutzvorrichtung nach Anspruch 1, bei welcher die Spreizstange (9) mehrere Glieder umfaßt, deren Gesamtlänge in wesentlichen mit der Länge der Klemmschiene (8) übereinstimmt.

4. Zweiteilige Elektrodenkantenschutzvorrichtung nach den Ansprüchen 2 oder 3, bei welcher der Isolierhartstoff aus Polypropylen besteht.

5. Zweiteilige Elektrodenkantenschutzvorrichtung nach den Ansprüchen 1, 2, 3, und/oder 4, bei welcher die Innenbacken (10) derartig proportioniert sind, daß eine Elektrodenkante (6) zwischen diesen nur streng bzw. reibungsschlüssig einpaßbar ist.

6. Zweiteilige Elektrodenkantenschutzvorrichtung nach den Ansprüchen 1, 2, 3, 4 and/oder 5, bei welcher der für die Spreizstange (9) vorgesehene Werkstoff eine höhere Wärmedehnzahl aufweist als der für die Klemmschiene (8) vorgesehene, was bei Temperaturanstieg eine entsprechende Steigerung der auf die Innenbacken (10) ausgeübten Hebelwirkung zur Folge hat.

7. Elektrode, ausgestattet mit zu mindest einer Kantenschutzvorrichtung nach den Ansprüchen 1, 2, 3, 4, 5 und/oder 6.

8. Elektrode nach Anspruch 7, bei welcher die mit Kantenschutz (7) zu versehenen Kanten (6) vorerst mit einem Dichtungsmittel beschichtet werden.

9. Elektrode nach Anspruch 8, bei welcher die Dichtungsmittelbeschichtung mittels Klebeband vorgenommen wird, welches auf die Elektrodenkante (6) sowohl als auch auf die an die Kante (6) angrenzenden Oberflächenstreifen der Elektrode (1) aufgetragen wird, bevor die Kante (6) in die binnen der beiden Innenbacken (10) verlaufende Nut (11) eingeschoben wird.

10. Elektrode nach Anspruch 9, bei welcher das Klebeband aus einseitig mit aushärtendem Klebstoff beschichtetem Polyesterfilm besteht.

11. Elektrode nach den Ansprüchen 7, 8, 9 und/oder 10, bei welcher die—allenfalls bei ihrem Einsatz—senkrecht-verlaufenden Kanten (6) und zusätzlich eine waagrechte Kante mit Kantenschutzvorrichtungen (7) ausgestattet sind.

12. Elektrode nach den Ansprüchen 7, 8, 9, 10 und/oder 11, dadurch gekennzeichnet, daß die Längenabmessung bei mindestens einer Kantenschutzvorrichtung (7) derartig vorgesehen ist, daß diese (7) über die Länge oder Breite der Elektrode (1) hinausragt.

13. Elektrode nach Anspruch 12, bei welcher ein Stück elastisches und zusammendrückbares Isoliermaterial (16) in dem binnen der hinausragenden Innenbacken (10) entstandenen Hohlraum von diesen dicht an den lotrecht zur Klemmschiene (8) im Bereich der Innenbacken (10) befindlichen Oberflächenteil des Endprofils der Elektrode (1) eingeklemmt ist.

14. Elektrode nach den Ansprüchen 12 oder 13, bei welcher der hinausragende Teil einer Kanten-

schutzvorrichtung (7) als Stütze, Träger und/oder Ortungsbefehl dient für jegliche Art von daran befestigten und/oder nichtbefestigten Geräten und/oder Vorrichtungen welche als Zusatzvorrichtung und/oder für jegliche sonstige Zwecke in Verbindung mit dem elektrolytischen Verfahren bestimmt sind, in welchem die Elektrode (1) eingesetzt werden soll.

15. Kathodisches Mutterblech, ausgestattet mit mindestens einer Kantenschutzvorrichtung (7) nach jeglichem, einem oder mehreren der Ansprüche 1 bis einschließlich 14.

Revendications

1. Protecteur marginal pour électrodes, comprenant des premier et second éléments allongés (8, 9), ces deux éléments (8, 9) étant constitués d'une matière rigide qui, en premier lieu, est électriquement isolante et, en second lieu, chimiquement et thermiquement stable dans l'environnement dans lequel on envisage d'utiliser l'électrode; le premier élément (8) ayant une section transversale généralement en "H", de façon à définir des rainures ouvertes (11, 13) sur ses faces opposées, une rainure (13) étant généralement profilée sous forme d'un segment circulaire plus grand qu'un demi-cercle, tout en étant définie entre une paire de mâchoires extérieures (12), tandis que l'autre rainure (11) est définie entre une paire de mâchoires intérieures (10), un bord (6) d'une électrode (1) pouvant être introduit et localisé à l'intérieur des mâchoires intérieures (10): et le second élément (9) est constitué d'un organe à section transversale circulaire dimensionné et façonné pour venir s'engager avec un ajustage serré entre les mâchoires extérieures (12), de telle sorte que ces dernières soient forcées davantage à l'écart l'une de l'autre en ayant ainsi tendance à fermer les mâchoires intérieures (10) qui sont déplacées l'une vers l'autre avec un effet de levier, exerçant ainsi une pression uniforme sur le bord (6) de l'électrode (1) lorsque celle-ci est localisée dans les mâchoires intérieures (10), afin de former un joint étanche destiné à empêcher l'électrolyte (2) d'imprégner le bord (6) de l'électrode localisée à l'intérieur des mâchoires intérieures (10).

2. Protecteur marginal selon la revendication 1, caractérisé en ce que les premier et second éléments allongés (8, 9) ont une longueur pratiquement égale et sont réalisés d'une seule pièce en une matière isolante rigide.

3. Protecteur marginal selon la revendication 1, caractérisé en ce que le second élément (9) est constitué de plusieurs pièces allongées, la somme totale des longueurs combinées de ces dernières étant pratiquement égale à la longueur du premier élément (8).

4. Protecteur marginal selon la revendication 2 ou 3, caractérisé en ce que la matière isolante est le polypropylène.

5. Protecteur marginal selon l'une quelconque des revendications précédentes, caractérisé en ce que les mâchoires intérieures (10) sont pro-

portionnées de façon à recevoir le bord (6) de l'électrode (1) avec un ajustage dit à friction.

6. Protecteur marginal selon l'une quelconque des revendications précédentes, caractérisé en ce que le second élément (9) est constitué d'une matière ayant un coefficient de dilatation thermique supérieur à celui de la matière dont est constitué le premier élément (8), de façon à améliorer l'effet de levier exercé sur les mâchoires intérieures à des températures élevées.

7. Electrode pourvue d'au moins un protecteur marginal du type défini dans l'une quelconque des revendications précédentes.

8. Electrode selon la revendication 7, caractérisée en ce que les bords (6) destinés à recevoir les protecteurs marginaux (7) sont pourvus de joints étanches.

9. Electrode selon la revendication 8, caractérisée en ce que l'étanchéité est assurée au moyen d'un ruban adhésif appliqué à la partie de l'électrode (1) qui est située à l'emplacement et à proximité du bord (6) qui est ultérieurement introduit dans les mâchoires intérieures (10).

10. Electrode selon la revendication 9, caractérisée en ce que le ruban adhésif est un ruban de polyester sur lequel est appliqué un adhésif thermodurcissable.

11. Electrode selon l'une quelconque des revendications 7 à 10, pourvue de protecteurs

marginaux (7) le long des bords (6) qui, du moins lors de l'utilisation, seront verticaux, et également le long d'un bord horizontal.

12. Electrode selon l'une quelconque des revendications 7 à 11, caractérisée en ce qu'au moins un protecteur marginal (7) a des dimensions longitudinales calculées de telle sorte qu'il ressorte au-delà de la longueur ou de la largeur de l'électrode (1).

13. Electrode selon la revendication 12, caractérisée en ce qu'une pièce de matière isolante compressible et élastique ou à effet de ressort (16) est enfermée à l'intérieur des mâchoires intérieures en saillie (10), de façon à entrer étroitement en contact avec la partie de la surface profilée de l'électrode (1) qui s'étend à l'intérieur des mâchoires intérieures (10) et dans un plan perpendiculaire à ces dernières à l'endroit où commence la saillie.

14. Electrode selon la revendication 12 ou 13, caractérisée en ce que la partie en saillie d'un protecteur marginal (7) est utilisée pour supporter et/ou localiser structurellement et/ou mécaniquement n'importe quel dispositif (qu'il y soit fixé ou non), lequel est un accessoire ou n'est en aucune manière en rapport avec le procédé électrolytique dans lequel l'électrode (1) doit être utilisée.

15. Plaque de matrice cathodique pourvue d'au moins un protecteur marginal selon l'une quelconque des revendications 1 à 14.

35

40

45

50

55

60

65

7

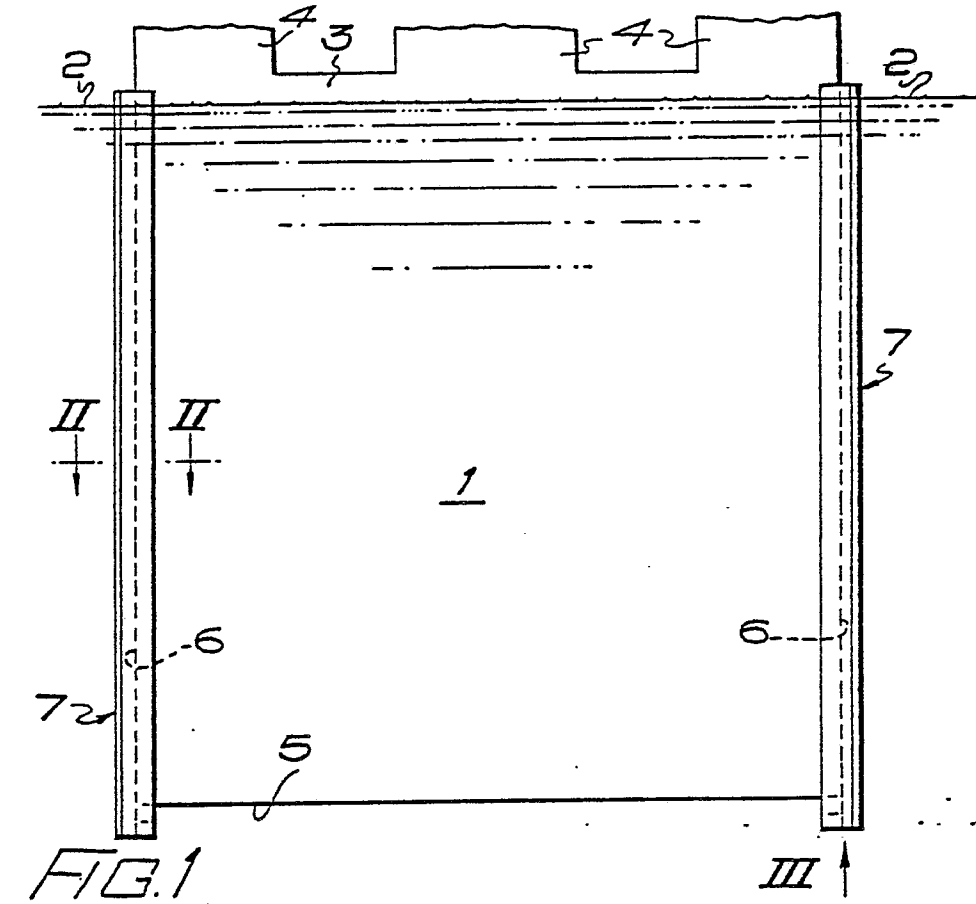

FIG. 1

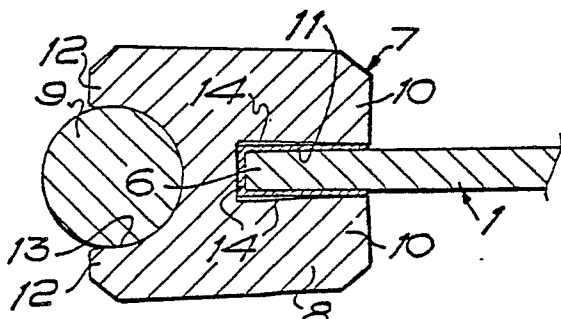

FIG. 2

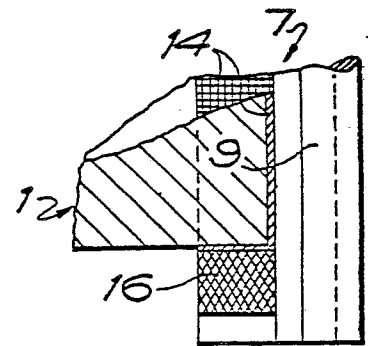

FIG. 4

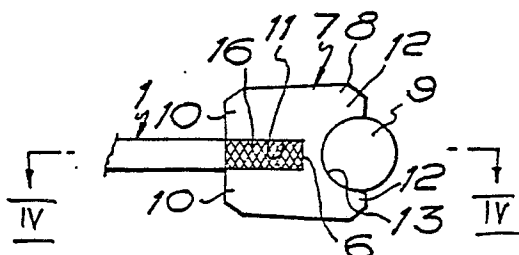

FIG. 3

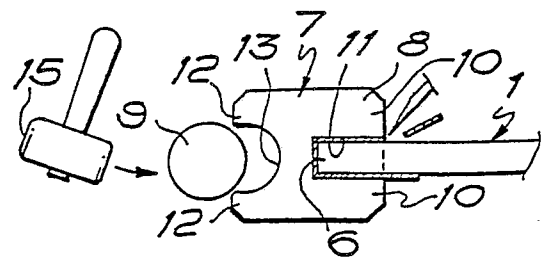

FIG. 5