

(19) World Intellectual Property Organization  
International Bureau



(43) International Publication Date  
12 April 2007 (12.04.2007)

PCT

(10) International Publication Number  
**WO 2007/041445 A1**

(51) International Patent Classification:  
*E01C 23/16* (2006.01)

(21) International Application Number:  
PCT/US2006/038337

(22) International Filing Date: 3 October 2006 (03.10.2006)

(25) Filing Language: English

(26) Publication Language: English

(30) Priority Data:  
11/243,715 5 October 2005 (05.10.2005) US

(71) Applicant (for all designated States except US): **3M INNOVATIVE PROPERTIES COMPANY** [US/US];  
3M Center, Post Office Box 33427, Saint Paul, Minnesota, Minnesota 55133-3427 (US).

(72) Inventors: **NORTHEY, Paul J.**; 3M Center, Post Office Box 33427, Saint Paul, Minnesota 55133-3427 (US). **MAY, David.C.**; 3M Center, Post Office Box 33427, Saint Paul, Minnesota 55133-3427 (US). **DVORSKY, Stephen, M.**; 3M Center, Post Office Box 33427, Saint Paul, Minnesota 55133-3427 (US). **TURNER, Michael, A.**; 3M Center, Post Office Box 33427, Saint Paul, Minnesota 55133-3427 (US).

(74) Agents: **NOWAK, Sandra, K.** et al.; 3M Center, Office Of Intellectual Property Counsel Post Office Box 33427, Saint Paul, Minnesota 55133-3427 (US).

(81) Designated States (unless otherwise indicated, for every kind of national protection available): AE, AG, AL, AM,

AT, AU, AZ, BA, BB, BG, BR, BW, BY, BZ, CA, CH, CN, CO, CR, CU, CZ, DE, DK, DM, DZ, EC, EE, EG, ES, FI, GB, GD, GE, GH, GM, HN, HR, HU, ID, IL, IN, IS, JP, KE, KG, KM, KN, KP, KR, KZ, LA, LC, LK, LR, LS, LT, LU, LV, LY, MA, MD, MG, MK, MN, MW, MX, MY, MZ, NA, NG, NI, NO, NZ, OM, PG, PH, PL, PT, RO, RS, RU, SC, SD, SE, SG, SK, SL, SM, SV, SY, TJ, TM, TN, TR, TT, TZ, UA, UG, US, UZ, VC, VN, ZA, ZM, ZW.

(84) Designated States (unless otherwise indicated, for every kind of regional protection available): ARIPO (BW, GH, GM, KE, LS, MW, MZ, NA, SD, SL, SZ, TZ, UG, ZM, ZW), Eurasian (AM, AZ, BY, KG, KZ, MD, RU, TJ, TM), European (AT, BE, BG, CH, CY, CZ, DE, DK, EE, ES, FI, FR, GB, GR, HU, IE, IS, IT, LT, LU, LV, MC, NL, PL, PT, RO, SE, SI, SK, TR), OAPI (BF, BJ, CF, CG, CI, CM, GA, GN, GQ, GW, ML, MR, NE, SN, TD, TG).

**Declarations under Rule 4.17:**

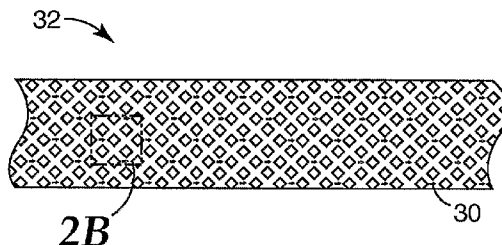
- as to applicant's entitlement to apply for and be granted a patent (Rule 4.17(ii))
- as to the applicant's entitlement to claim the priority of the earlier application (Rule 4.17(iii))

**Published:**

- with international search report
- before the expiration of the time limit for amending the claims and to be republished in the event of receipt of amendments

For two-letter codes and other abbreviations, refer to the "Guidance Notes on Codes and Abbreviations" appearing at the beginning of each regular issue of the PCT Gazette.

(54) Title: OPTICALLY ACTIVE SHEETS INCLUDING A MARK INDICATING A PREFERRED SHEET ORIENTATION



(57) Abstract: One exemplary optically active material includes a mark that facilitates identification of a preferred application orientation of the material without significantly affecting the optical properties of the material. Another exemplary optically active material is wound into a roll including multiple, individual strips of pre-measured tape. Adjacent strips are separated by a separation line that can be, for example, a perforated separation line or a complete cut that fully separates the adjacent strips.

WO 2007/041445 A1

## OPTICALLY ACTIVE SHEETS INCLUDING A MARK INDICATING A PREFERRED SHEET ORIENTATION

### Background

5           Optically active materials, such as, for example, reflective and retroreflective materials, may be used for roadside signage and pavement marking. One exemplary type of optically active material used for pavement marking is pavement marking tape. Pavement marking tapes are typically used to delineate the boundaries for lanes of traffic on a roadway. The tape may extend continuously, such as along the outermost boundaries  
10 of the driving lanes, or intermittently, such as between lanes. One popular use for such a tape is in construction work zones, where pavement marking tape can guide motorists through new traffic patterns without incident.

### Summary

15           Various embodiments of the present invention relate to optically active pavement marking tapes, optically active sheets and strips, and methods of making and using each.

          In one embodiment, an optically active material includes a mark formed on or through the optically active material to facilitate identification of a preferred application orientation of the material. Further, the mark does not significantly affect the optical  
20 properties of the optically active material. The optically active material may be, for example, a pavement marking tape or reflective sheeting. The mark may be, for example, embossed onto or cut into the sheet to form an alphanumeric symbol, an arrow, a directional indicator, or a score mark. Further, the mark may comprise the shape of the sheet or may have a color that differs from the color of the sheet.

25           One method of applying a sheet of optically active pavement marking tape having a mark formed thereon and/or involves: (1) providing a piece of pavement marking tape; (2) detecting an application orientation indicating mark formed on or through at least a portion of the piece of pavement marking tape; (3) orienting the piece of pavement marking tape on the desired surface in accordance with the mark; and (4) applying the  
30 piece of pavement marking tape to the desired surface.

In some embodiments, the optically active material is wound to form a roll, and each roll includes multiple individual sheets or strips of pavement marking tape. Each sheet or strip is separated from an adjacent sheet or strip by a separation line. In some embodiments, the separation line extends along the width of each sheet or strip. The separation line may include, for example, a plurality of perforations, cuts, slits, or variegated holes that partially separate adjacent sheets or strips. Alternatively, the separation line may be a cut that completely separates adjacent sheets or strips from one another.

### Brief Description of the Drawings

The present invention will be further explained with reference to the appended Figures, wherein like structure is referred to by like numerals throughout the several views, and wherein:

Fig. 1 is a pictorial view of a strip of pavement marking tape having a shape that forms a mark indicating a preferred application orientation of the strip of pavement marking tape;

Figs. 2-4 are enlarged pictorial views of a portion of three separate exemplary strips of pavement marking tape onto or through each which has been formed a mark in the form of an arrow that indicates a preferred application orientation of the strip of pavement marking tape;

Figs. 5-7 are pictorial views of a portion of three separate exemplary strips of pavement marking tape onto or through each of which has been formed a mark that indicates a preferred application orientation of the strip of pavement marking tape;

Figs. 8 and 9 are pictorial views of the opposite ends of two exemplary strips of pavement marking tape each of which includes a mark that indicates a preferred application orientation of the strip of pavement marking tape;

Fig. 10 is a pictorial view of a roll of pavement marking tape including multiple sheets of tape that are each completely separated from an adjacent sheet of tape along a separation line;

Fig. 11 is pictorial view of a roll of pavement marking tape including multiple sheets of tape that are each separated from an adjacent sheet of tape by a perforated separation line; and

Figs. 12-14 are pictorial views showing various exemplary patterns for the perforated separation line.

### Detailed Description

5           The present patent application describes more expedient and accurate methods of applying an optically active material, *e.g.*, pavement marking tape or sheeting, to a desired substrate or surface such that the pavement marking tape is applied to the desired surface in a preferred orientation, *e.g.*, with the brightest portion of the pavement marking tape facing the driver. One exemplary optically active material for use in practicing these  
10 methods includes an application orientation indicating mark that indicates the orientation in which the optically active material should be applied to the desired surface.

          The present patent application further describes more expedient and accurate methods of preparing an optically active material, *e.g.*, pavement marking tape, to be applied to a desired surface. One exemplary pavement marking tape is wound in a roll that  
15 includes multiple, individual sheets of pre-measured tape that are separated from an adjacent sheet by a separation line and that can be quickly and easily removed from the roll and applied to the desired surface.

          The methods of the present invention are useful for preparing and using optically active materials to create roadside signage and pavement markings. The above-described  
20 methods, and the optically active materials for use in practicing the methods, are more accurate and reliable than previous methods and materials because they minimize reliance on human assessment or measurement of the optically active materials. Specifically, the application of optically active materials to a desired surface currently requires the person applying the material to (1) determine the preferred application orientation of the optically  
25 active material and (2) to measure and cut the optically active material. This reliance on human assessment and measurement introduces the potential for error to occur.

          To simplify terminology used, the following discussion and Figures proceed with specific reference to pavement marking tape but the present invention includes any optically active material, including, but not limited to, reflective and retroreflective

sheeting. Further, the terms "sheet" and "strip" are used interchangeably to refer to a piece of pavement marking tape that can be applied to a desired surface.

While any type of pavement marking tape is within the scope of the present invention, the composition of an exemplary pavement marking tape comprises ceramic fibers dispersed within a polymeric material. In addition to the ceramic fibers, the pavement marking composition may further comprise other fibers, and in particular non-thermoplastic organic fibers such as polyester fibers, polyolefin fibers, and mixtures thereof. Fillers may also be included in the composition at least for the purpose of enhancing the visibility of the exposed top layer. However, fillers may also advantageously enhance properties such as reinforcement, extending, surface hardness, and abrasion resistance. Pavement marking sheeting or tape may include a pressure sensitive adhesive for bonding the sheet to a roadway surface. The initial coefficient of retroreflected luminance (RL) of some preferred pavement markings is at least 1000 millicandelas/lux/m<sup>2</sup>. For such embodiments, the initial coefficient of retroreflected luminance, RL, may be at least 1500 millicandelas/lux/m<sup>2</sup>, at least 1800 millicandelas/lux/m<sup>2</sup>, at least 2000 millicandelas/lux/m<sup>2</sup>, at least about 2200 millicandelas/lux/m<sup>2</sup>, at least 2500 millicandelas/lux/m<sup>2</sup>, or greater. Further, some preferred pavement marking materials have a water vapor transmission rate (WVTR) of at least 2 g/m<sup>2</sup>/day according to ASTM F1249. Exemplary commercially available pavement marking tapes include those manufactured by 3M of St. Paul, Minnesota.

#### Pavement Marking Tape Including a Mark Indicating a Preferred Application Orientation

Currently, workmen applying pavement marking tape to a desired surface, *e.g.*, roadway or pavement, visually inspect the pavement marking tape to determine in what orientation to apply the tape to the pavement. The preferred orientation is not always immediately visible, so hurried workmen often affix the pavement marking tape to the pavement in the incorrect orientation. Because some embodiments of retroreflective pavement marking tape are approximately 15% brighter when viewed from one direction than from the other direction, incorrect placement may result in a significant decrease or

increase in expected brightness. In some instances, it may be preferable to have the pavement marking tape applied to the pavement such that the portion of the pavement marking tape having enhanced brightness will be viewed by a driver (*i.e.*, the view of highest brightness faces the driver). In some instances, it may be desirable to have the portion of the pavement marking tape having decreased brightness viewed by the driver (*i.e.*, the view of lower brightness faces the driver). Although the commercial success of pavement marking tape has been impressive, the present inventors recognized that there is currently no quick and easy application method to ensure and verify that the pavement marking tapes are applied to the desired substrate in the desired orientation.

It may thus be desirable to form a pavement marking tape having an application orientation indicating mark that indicates a preferred application orientation without significantly negatively affecting an optical property of the pavement marking tape. While any type of an application orientation indicating mark falls within the scope of the invention, some exemplary marks are shown in Figs. 1-9. These application orientation indicating marks may be formed on either or both of the viewing or non-viewing surface of the pavement marking tape.

The diamond pattern on the strips shown in Figs. 1-4 indicates that these strips are retroreflective. Commercially available retroreflective pavement marking strips having a diamond pattern are manufactured by 3M of St. Paul, Minnesota and sold under the trade name Stamark™.

As shown in Fig. 1, the shape of a strip 10 of retroreflective pavement marking tape forms an application orientation indicating mark indicating a preferred application orientation of strip 10. Strip 10 includes a front side 12, a rear side 14, and opposed first and second side margins 16 and 18. Strip 10 has the general shape of an arrow. Specifically, strip 10 has a generally convexo-concave shape that includes a v-shaped front side 12 that forms a first point 22 and a negatively v-shaped rear side 14 that forms a second point 24.

Alternative generally arrow shaped strips 10 may have rounded front 12 and rear 14 sides that form convexo-concave and concavo-convex pavement marking strips 10. In another alternative generally arrow shaped strip, one of front 12 and rear 14 sides is shaped and the other is substantially linear. For example, first side 12 may be v-shaped to form a

first point 22 and rear side 14 may be linear. Those of skill in the art will recognize that numerous other alternative arrow and non-arrow shapes are included in the scope of the present invention.

As shown in Figs. 2-4, a directional application orientation indicating mark 30, such as an arrow, may be embossed or cut into a strip 32 of pavement marking material using embossing and cutting methods known to those of skill in the art. The shape, location, size, frequency, pattern, and color of directional mark 30 may vary based on the thickness, color, sheet material, desired end use, etc., of strip 32 of pavement marking tape. A single hole formed adjacent to one of front and rear sides 12 and 14 may act as a directional application orientation indicating mark. Taking these factors into consideration, a strip having the end-user's desired properties can be formed. The alternative embodiments of exemplary pavement markings tapes shown in Figs. 1-4 can be applied to the center, middle, or sides of a road.

Figs. 5-7 show alternative embodiments of pavement marking tape strips that are well suited for application to the side of a road. Fig. 5 shows a portion of a strip 40 of pavement marking tape having score marks 42 embossed or cut onto or into one of first and second opposed side margins 16 and 18. The workmen affixing strip 40 to the pavement can be instructed to affix strip 40 such that score mark 42 is adjacent to or points toward the ditch or can be instructed to affix strip 40 such that score mark 42 is on the opposite side of the ditch. Score marks 42 shown in Fig. 5 are uniformly spaced and have a uniform size and length, however, these are only exemplary and those of skill in the art will recognize that any type of score mark may be used and still fall within the scope of the present invention.

Fig. 6 shows a portion of a strip 50 of pavement marking tape onto which has been formed a word 52 that indicates a preferred application orientation of strip 50. The word may be formed onto strip 50 in any manner known to those of skill in the art, including embossing and cutting. The word may be formed on either of first and second opposed side margins 16 and 18. The word specifically shown in Fig. 6 is DITCH, but any word, combination of characters, single character, portion of a word, symbol, or alphanumeric character can be used. An exemplary preferred application of strip 50 would involve affixing strip 50 on the pavement such that the word DITCH was adjacent to the ditch

portion of the road. Alternative exemplary embodiments would include the word ROAD or some other indication thereof on the opposed side margin of strip 50.

Fig. 7 shows a portion of a strip 60 of pavement marking tape onto which has been formed a symbol 62 that forms an application orientation indicating mark that indicates a preferred application orientation of strip 60. The symbol may be formed onto strip 60 in any manner known to those of skill in the art, including embossing and cutting. The symbol may be formed on either of first and second opposed side margins 16 and 18 of strip 60. The workmen affixing strip 60 to the pavement can be instructed to affix strip 60 such that symbol 62 is adjacent to or points toward the ditch or can be instructed to affix strip 60 such that symbol 62 is on the opposite side of the ditch. The X symbols 62 shown in Fig. 7 are uniformly spaced and have a uniform size, however, these are only exemplary and those of skill in the art will recognize that any type of symbol having any size, pattern, and frequency may be used and still fall within the scope of the present invention.

Figs. 8 and 9 show exemplary pavement markings tape strips that can be applied to the center, middle, or sides of a road. The middle portion of the strips shown in Figs. 8 and 9 has been cutaway and only front 12 and rear 14 ends of each strip are shown. Strip 80 shown in Fig. 8 includes an alphanumeric character on each of front 12 and rear 14 ends. The alphanumeric character is preferably chosen to indicate the preferred application orientation of strip 80. The alphanumeric character on front end 12 of strip 80 is an "F" indicating that it is adjacent the front end 12 of strip 80 and the alphanumeric character on the rear end 14 of strip 80 is an "R" indicating that it is adjacent the rear 14 of strip 80. Those of skill in the art will appreciate that any alphanumeric character or other indicator may be used to indicate the preferred application orientation.

Strip 90 of Fig. 9 includes multiple arrows formed onto the front and rear sides 12 and 14 of strip 90 by, for example, cutting or embossing. As stated above with respect to other alternative embodiments, these arrows may have any preferred size, shape, color, texture, and thickness that is desired.

In some embodiments, the shape of the pavement marking tape strip is visible to the person affixing the strip to the pavement but is not readily visible to a driver casually glancing at the strips as they drive past. One such exemplary embodiment involves the application of color to at least one edge, *e.g.*, to the front or back side margin, of a strip of

pavement marking tape. Differentiating a side margin or side wall surface of a sheet or strip of pavement marking tape by applying a color to that side margin or side wall surface forms an application orientation indicating mark that would facilitate correct application of the sheet or strip of the pavement marking tape. However, the colored side margin or side wall surface might not be visible to a driver on the roadway. The color could be applied in any way known to those of skill in the art and could be applied at any time, including during manufacturing of the tape or while applying the tape. Further, embossed or otherwise raised or lowered marks may wear off during normal use of the pavement marking tape and thus may not be visible to drivers on the roadway and may be visible to the people applying the tape to the desired surface only during application.

#### Rolls of Pavement Marking Tape Including Multiple, Individual Sheets of Tape

The following discussion relates to one exemplary type of optically active material, pavement marking tape. Pavement marking tape is typically transported in a large, continuous roll. A popular method for preparing and applying pavement marking tape skip dashes involves two or more workmen unwinding the pavement marking tape from the roll, placing the unwound portion of the tape onto a board, measuring the desired length of tape, and then hand-cutting the tape to the desired length. Stacks of these hand-cut pieces of pavement marking tape are then transported to the application site. Although the commercial success of this method and its related products has been impressive, the present inventors recognized that this process is prone to human error. Further, this process can be expensive because it is often the rate-limiting step in the process of pavement marking tape application and it completely occupies the time of two or more workmen.

The inventors of the present application recognized that an optically active material can be wound to form a roll that includes multiple individual sheets or strips of pavement marking material wherein each sheet or strip is separated from an adjacent sheet or strip by a separation line. The separation line may include, for example, a plurality of perforations, cuts, slits, or variegated holes that partially separate adjacent sheets. Alternatively, the separation line may be a cut that completely separates adjacent sheets from one another.

As shown in Figs. 10 and 11, a roll 100 of pavement marking tape includes multiple, individual, sheets 102 of pavement marking tape arranged end-to-end. Adjacent sheets 102 are separated by a separation line 104, which can be, for example, a perforated separation line 104<sub>p</sub> as shown in Fig. 11 or a complete cut 104<sub>c</sub> that fully separates adjacent sheets 102 as shown in Fig. 10. Separation line 104 facilitates quick, easy, and accurate removal of individual sheets 102 from roll 100.

Pavement marking tape includes a first optically active major surface 110 and an opposed second major surface 112. As shown in Figs. 10 and 11, roll 100 may be wound such that optically active first major surface 110 faces outwardly of or away from the center of roll 100, and second major surface 112 faces inwardly of or toward the center of roll 100. Alternatively, optically active first major surface 110 may face inwardly of or toward the center of roll 100 and second major surface 112 may face outwardly of or away from the center of roll 100. Roll 100 may be wound and otherwise formed by conventional methods.

Roll 100 is not shown as including a core or any support material, but roll 100 may optionally include a core wherein the multiple sheets 102 of pavement marking tape are wrapped/wound around the core. Roll 100 may optionally include a liner interposed between each or some of the multiple wraps of pavement marking tape.

Each sheet 102 in roll 100 has a length  $L$  and a width  $W$ . Width  $W$  of each sheet 102 preferably substantially equals the circumference of roll 100. Length  $L$  of each sheet 102 is determined by the distance between adjacent separation lines 104 and can be tailored to the specifications of the end-user. However, a preferred length  $L$  is between about 5 feet and about 20 feet, more preferably between about 10 feet and about 15 feet.

As shown in Fig. 11, some embodiments of roll 100 include adjacent sheets 102 separated by a transverse, perforated separation line 104<sub>p</sub>. The use of perforated separation

lines 104<sub>p</sub> is well known in the field of paper, tissue, and towels. For example, U.S. Patent No. 5,704,566 discloses a roll of paper towels that may be separated into toweling segments by pulling the paper towels along a perforated tear line. However, no one has formed pre-measured, perforated separation lines 104<sub>p</sub> in pavement marking tape.

5 Perforated separation line 104<sub>p</sub> includes multiple slits, cuts, or holes that are separated from an adjacent slit, cut, or hole by sheet material, which is herein referred to as a bonded area 120. The number of slits, cuts, or holes in any perforated separation line 104<sub>p</sub> will depend on a variety of factors including the width *W* of each sheet 102; the size (e.g., length and diameter) of each slit, cut, or hole; the type of material used to form sheet  
10 102; and the intended use for sheet 102. The number of slits, cuts, or holes formed in each perforated separation line 104<sub>p</sub> can be determined by one of skill in the art taking into consideration the above-identified factors. Perforated separation lines 104<sub>p</sub> are formed using commonly known techniques and machines. Perforated separation line 104<sub>p</sub> can be formed before the pavement marking tape is rolled onto roll 100 or can be formed after roll  
15 100 has been wound.

Perforated separation lines 104<sub>p</sub> between sheets 102 may be formed at regular intervals to allow the user to remove a pre-defined, pre-measured, length *L* of pavement marking tape and to easily separate that strip of tape from roll 100. Alternatively, perforated separation lines 104<sub>p</sub> on sheets 102 may be formed at random or irregular  
20 intervals.

While any type of perforated separation line 104<sub>p</sub> falls within the scope of the invention, some exemplary perforated separation lines 104<sub>p</sub> are shown in Figs. 12-14.

Figs. 11 and 12 show a perforated separation line 104<sub>p</sub> including a plurality of cuts or slits 122. The portions of pavement marking tape shown in Figs. 11 and 12 have  
25 approximately equal length slits 122. In an alternative embodiment (not shown), slits 122 are longer toward the side edges 124 and 126 of sheet 102 than in the middle. This formation of perforated separation line 104<sub>p</sub> facilitates tearing of sheet 102 from roll 100.

Fig. 13 shows a perforated separation line 104<sub>p</sub> including multiple variegated holes 130 formed in sheet 102. The diameter of each variegated hole 130 may be generally  
30 uniform, as shown in Fig. 13, or may be variable. In an alternative embodiment (not

shown), the diameter of variegated holes 130 increases toward the edges 124 and 126 of sheet 102 to facilitate tearing of sheet 102 from roll 100.

Fig. 14 shows a perforated separation line 104<sub>p</sub> including a combination of slits 122 and variegated holes 130. The length, diameter, pattern, and spacing of slits 122 and holes 130 can be variable or regular.

The user is preferably able to readily visually identify the location of perforated separation line 104<sub>p</sub> in sheet 102. The visibility of perforated separation line 104<sub>p</sub> is related to the length of each slit 122, cut, or hole 130 in sheet 102. Slits 122, cuts, or holes 130 having a size that provides easy recognition by the user may be preferred in some embodiments. However, if the slits 122, cuts, or holes 130 are too large, the strength of bonded area 120 suffers and roll 100 is weaker because the size of bonded area 120 is minimized. In addition to other factors such as the type of sheet material, the ratio of perforated area to bonded area 120 affects a perforation detach strength characteristic of sheet 102. The perforation detach strength characteristic can be controlled to meet an end user's specifications, as will be readily understood by one of skill in the art. Because roll 100 may differ in sheet material, sheet thickness, perforation detach strength, number of wraps, etc., it is desirable to consider these competing interests when forming each roll 100.

One method of separating one individual sheet 102 from the immediately adjacent sheet 102 on roll 100 involves the following steps: (1) the user unrolls or unwinds the desired sheet 102 from roll 100 so that the desired sheet is freely hanging from roll 100; and (2) the user then tugs, pulls, or tears the freely hanging sheet 102 from the adjacent sheet 102 on roll 100 while controlling the rotation of roll 100, for example, with the other hand.

One advantage of the above-described methods and sheets is that the measuring and cutting of the sheets is more accurate since there is less reliance on human measurement and cutting to effect sheet separation. This results in an increase in ease with which individual sheets may be separated from one another and an increased efficiency with which the sheets may be applied to the desired surface. Further, the total cost of applying the sheets to a desired surface is reduced because fewer humans are required to be present at the worksite.

The foregoing description and examples have been given for clarity of understanding only. No unnecessary limitations are to be understood therefrom. It will be apparent to those skilled in the art that many changes can be made to the above-described embodiments without departing from the scope of the present invention. Thus, the scope  
5 of the present invention should not be limited to the exact details and structures described herein, but rather by the structures described by the language of the claims, and the equivalents of those structures.

What is claimed is:

1. A method of applying a piece of optically active pavement marking tape to a desired surface, comprising:

providing a piece of pavement marking tape;

5 detecting an application orientation indicating mark formed on or through at least a portion of the piece of pavement marking tape;

orienting the piece of pavement marking tape on the desired surface in accordance with the mark; and

applying the piece of pavement marking tape to the desired surface.

10

2. The method of claim 1, in which the pavement marking tape is in the form of a roll that includes multiple pieces of pavement marking tape each of which is separated from an adjacent piece of pavement marking tape by a separation line.

15 3. The method of claim 2, in which the separation line includes a plurality of perforations, cuts, slits, or variegated holes.

4. The method of claim 2, in which the separation line completely separates adjacent pieces of pavement marking tape.

20

5. The method of claim 1, in which the mark is embossed on the pavement marking tape.

6. The method of claim 1, in which the mark is an alphanumeric character.

25

7. The method of claim 1, in which a mark color differs from a pavement marking tape color.

8. The method of claim 1, in which the mark is a score mark.

30

9. The method of claim 1, in which the piece of pavement marking tape is retroreflective.

10. An optically active pavement marking tape, comprising:

5 a mark formed on or through the pavement marking tape that facilitates identification of a preferred application orientation of the pavement marking tape without significantly affecting an optical property of the pavement marking tape.

10 11. The pavement marking tape of claim 10, in which the mark is embossed in the pavement marking tape.

15 12. The pavement marking tape of claim 10, in which the mark is one of an alphanumeric character, a score mark, an arrow, the shape of a strip of the pavement marking tape, or a combination thereof.

13. The pavement marking tape of claim 10, in which the mark has a mark color that differs from a pavement marking tape color.

20 14. The pavement marking tape of claim 10, in which the pavement marking tape is retroreflective.

25 15. The pavement marking tape of claim 10, in which the pavement marking tape is wound in a roll that includes a plurality of individual strips of pavement marking tape each of which has a length and a width and each of which is separated from an adjacent strip of pavement marking tape by a separation line that extends along the width of each strip.

30 16. The pavement marking tape of claim 15, in which the separation line includes a plurality of perforations, cuts, slits, or variegated holes that partially separate adjacent strips of pavement marking tape.

17. The pavement marking tape of claim 15, in which the separation line completely separates adjacent strips of pavement marking tape.

18. In an optically active sheet that can be viewed from a first direction and from a  
5 second direction and in which a degree of brightness of the sheet is greater when viewed from the first direction and is less when viewed from the second direction, an improvement comprising:

a mark on or through the optically active sheet, the mark facilitating identification of  
the

10 first and second directions, the mark being visually accessible without significantly impacting the optical properties of the optically active sheet.

19. The sheet of claim 18, in which the sheet is selected from a group consisting essentially of pavement marking tape and reflective sheeting.

15 20. The sheet of claim 18, in which the mark is one of embossed onto or cut into the sheet.

21. The sheet of claim 18, in which the mark is an alphanumeric character, a score  
20 mark, an arrow, the shape of the sheet, or a combination thereof.

22. The sheet of claim 18, in which the mark has a mark color that differs from a sheet color.

25 23. The sheet of claim 18, in which the sheet is retroreflective.

24. A roll of pavement marking material, comprising:

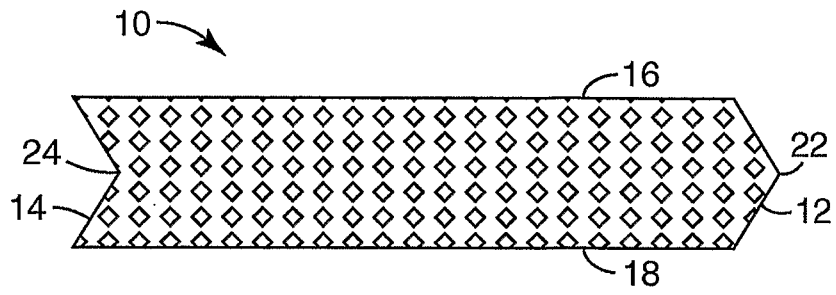
a plurality of individual strips of pavement marking material each of which is at least  
partially separated from an adjacent strip of pavement marking material along a separation  
30 line, each strip having a length and a width and the separation line extending along the width of each strip.

25. The roll of pavement marking material of claim 24, in which the individual sheets are completely separated from one another.

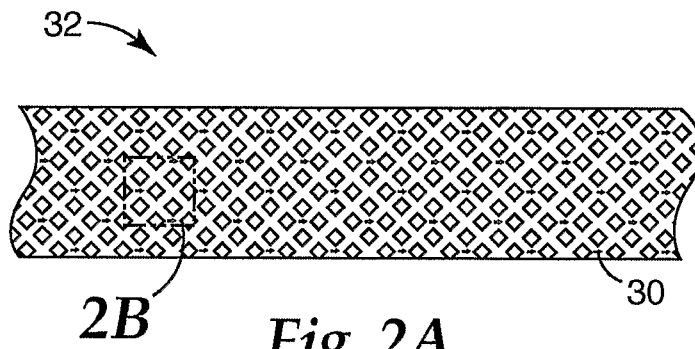
5 26. The roll of pavement marking material of claim 24, in which the separation line includes a plurality of perforations, cuts, slits, or variegated holes.

27. The roll of pavement marking material of claim 24, in which each strip has a length that is at least double the width of the strip.

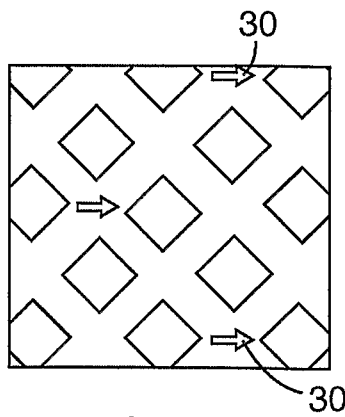
1/5



*Fig. 1*

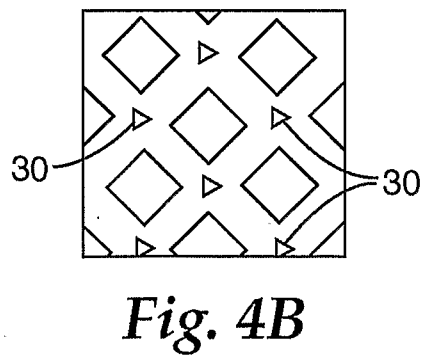
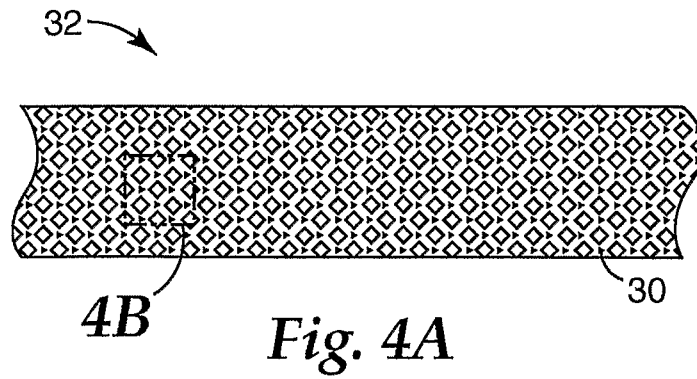
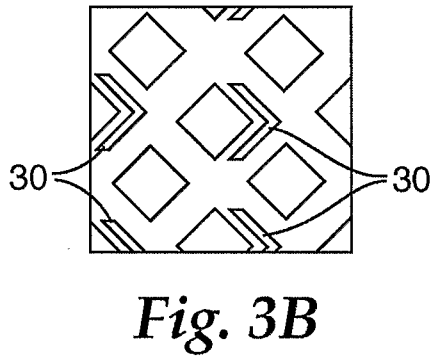
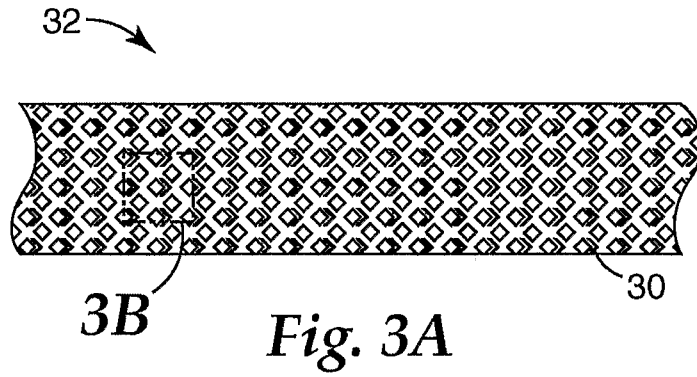


*Fig. 2A*

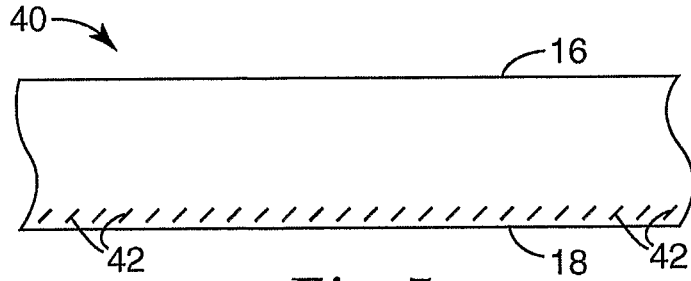


*Fig. 2B*

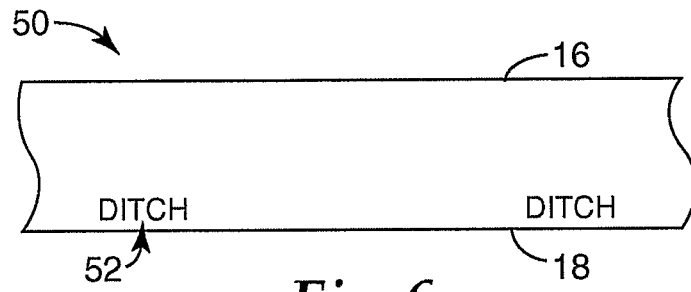
2/5



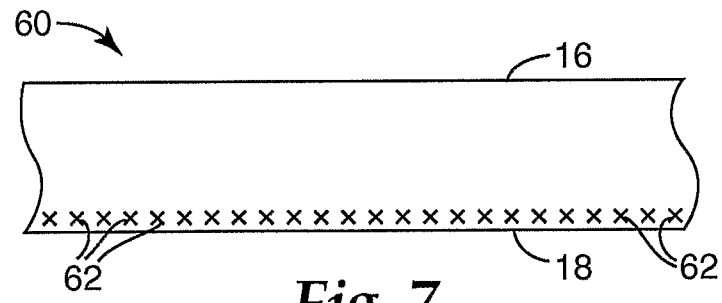
3/5



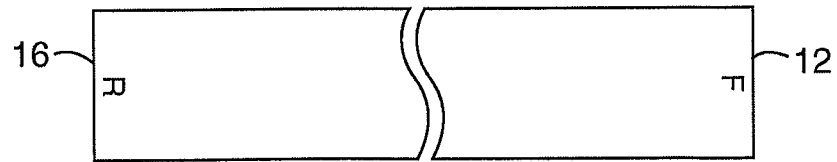
*Fig. 5*



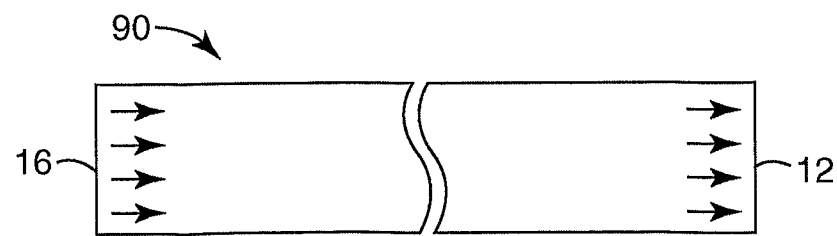
*Fig. 6*



*Fig. 7*

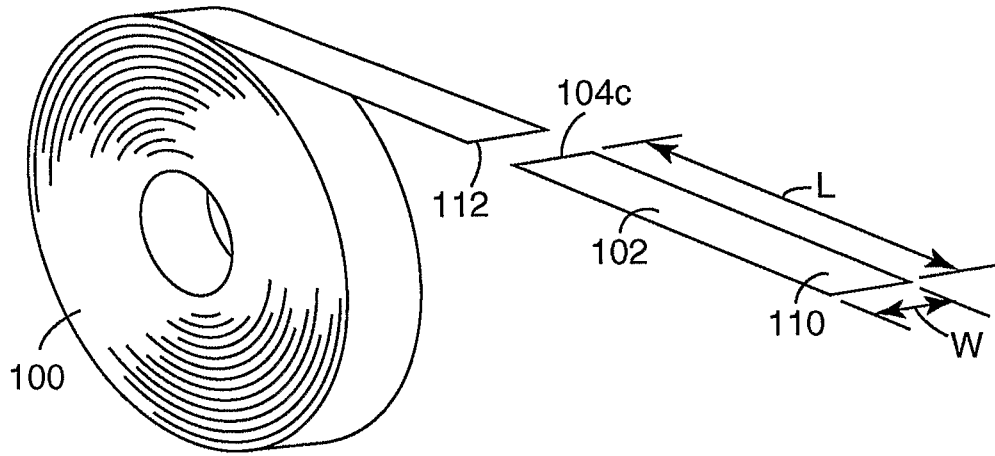


*Fig. 8*

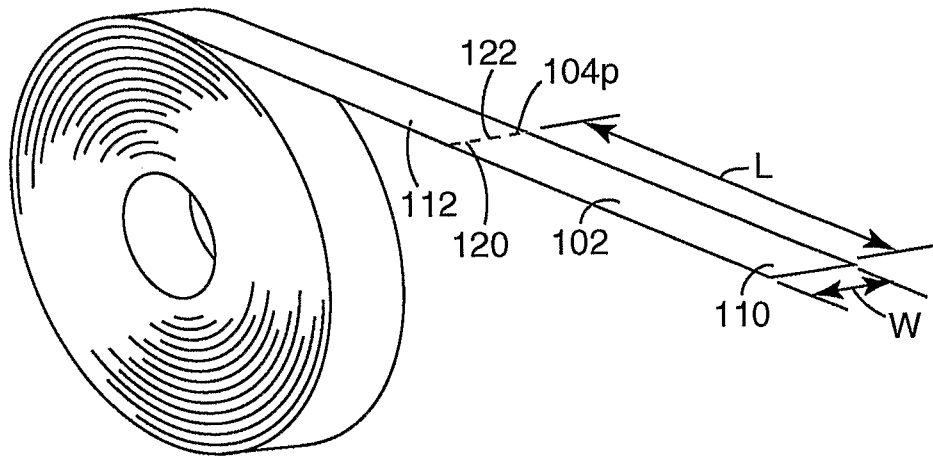


*Fig. 9*

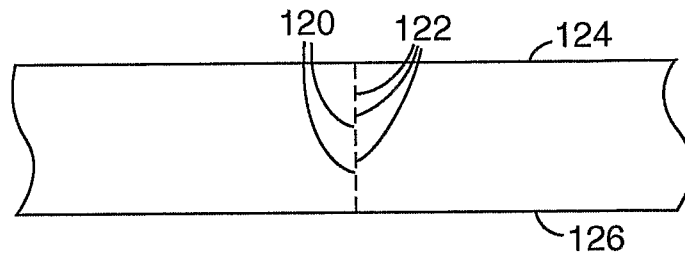
4/5



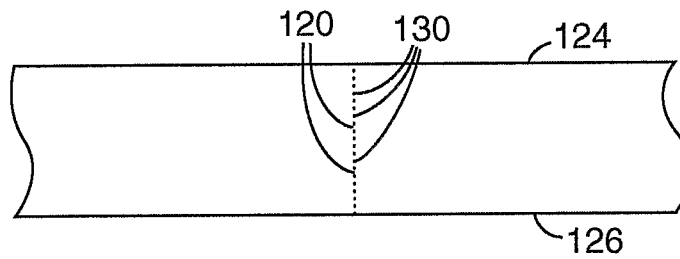
**Fig. 10**



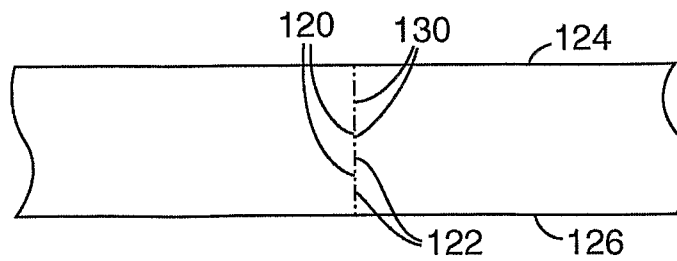
**Fig. 11**



**Fig. 12**





**Fig. 13**



**Fig. 14**

**INTERNATIONAL SEARCH REPORT**

International application No.  
PCT/US2006/038337

<b>A. CLASSIFICATION OF SUBJECT MATTER</b>		
<i>E01C 23/16(2006.01)i</i>		
According to International Patent Classification (IPC) or to both national classification and IPC		
<b>B. FIELDS SEARCHED</b>		
Minimum documentation searched (classification system followed by classification symbols) IPC8 E01C 23/00, 23/08, 23/16, E04B 2/00		
Documentation searched other than minimum documentation to the extent that such documents are included in the fields searched  KR, JP: IPC as above		
Electronic data base consulted during the international search (name of data base and, where practicable, search terms used)  eKIPASS (KIPO internal) & keywords: pave, road, mark, tape, strip, sheet, and reflect		
<b>C. DOCUMENTS CONSIDERED TO BE RELEVANT</b>		
Category*	Citation of document, with indication, where appropriate, of the relevant passages	Relevant to claim No.
A	US 5772359 A (JOHN L. MARTY) 30 June 1998 See the abstract	1, 10
A	US 4102718 A (LUDWIG EIGENMANN) 25 July 1978 See Figs. 1-5, and claim 1	1, 10
A	US 6326053 B1 (LARRY K. STUMP ET AL.) 04 December 2001 See Figs. 1-6, and the abstract	1, 10, 23
A	KR 10-1998-0009662 A (UM, JAE HAK) 30 April 1998 See Figs. 1-3, and the abstract	1, 10
A	KR 20-0276464 Y1 (KIM, SU SIN) 11 May 2002 See Figs. 1-5, and claims 1-4	1, 18, 23
A	KR 10-2003-0062947 A (JUEN STEEL ART CORP.) 28 July 2003 See Figs. 1-5, and the abstract	1, 10, 23
A	JP 11-140810 A (WATANABE TAKEO) 25 May 1999 See claim 1	1, 10
<input type="checkbox"/> Further documents are listed in the continuation of Box C. <input checked="" type="checkbox"/> See patent family annex.		
* Special categories of cited documents: "A" document defining the general state of the art which is not considered to be of particular relevance "E" earlier application or patent but published on or after the international filing date "L" document which may throw doubts on priority claim(s) or which is cited to establish the publication date of citation or other special reason (as specified) "O" document referring to an oral disclosure, use, exhibition or other means "P" document published prior to the international filing date but later than the priority date claimed "T" later document published after the international filing date or priority date and not in conflict with the application but cited to understand the principle or theory underlying the invention "X" document of particular relevance; the claimed invention cannot be considered novel or cannot be considered to involve an inventive step when the document is taken alone "Y" document of particular relevance; the claimed invention cannot be considered to involve an inventive step when the document is combined with one or more other such documents, such combination being obvious to a person skilled in the art "&" document member of the same patent family		
Date of the actual completion of the international search  07 FEBRUARY 2007 (07.02.2007)		Date of mailing of the international search report  <b>07 FEBRUARY 2007 (07.02.2007)</b>
Name and mailing address of the ISA/KR  Korean Intellectual Property Office 920 Dunsan-dong, Seo-gu, Daejeon 302-701, Republic of Korea Facsimile No. 82-42-472-7140		Authorized officer  JEONG, Kyu Young  Telephone No. 82-42-481-8124 

## INTERNATIONAL SEARCH REPORT

International application No.

PCT/US2006/038337

### Box No. II Observations where certain claims were found unsearchable (Continuation of item 2 of first sheet)

This international search report has not been established in respect of certain claims under Article 17(2)(a) for the following reasons:

1.  Claims Nos.:  
because they relate to subject matter not required to be searched by this Authority, namely:
  
2.  Claims Nos.:  
because they relate to parts of the international application that do not comply with the prescribed requirements to such an extent that no meaningful international search can be carried out, specifically:
  
3.  Claims Nos.:  
because they are dependent claims and are not drafted in accordance with the second and third sentences of Rule 6.4(a).

### Box No. III Observations where unity of invention is lacking (Continuation of item 3 of first sheet)

This International Searching Authority found multiple inventions in this international application, as follows:

1.  As all required additional search fees were timely paid by the applicant, this international search report covers all searchable claims.
2.  As all searchable claims could be searched without effort justifying an additional fee, this Authority did not invite payment of any additional fee.
3.  As only some of the required additional search fees were timely paid by the applicant, this international search report covers only those claims for which fees were paid, specifically claims Nos.:
  
4.  No required additional search fees were timely paid by the applicant. Consequently, this international search report is restricted to the invention first mentioned in the claims; it is covered by claims Nos.:

#### Remark on Protest

- The additional search fees were accompanied by the applicant's protest and, where applicable, the payment of a protest fee.
- The additional search fees were accompanied by the applicant's protest but the applicable protest fee was not paid within the time limit specified in the invitation.
- No protest accompanied the payment of additional search fees.

**INTERNATIONAL SEARCH REPORT**

Information on patent family members

International application No.

PCT/US2006/038337

Patent document cited in search report	Publication date	Patent family member(s)	Publication date
US 5772359 A	30.06.1998	(NONE)	
US 4102718 A	25.07.1978	IT1054055A IT1123079A SE7700152A	10.11.1981 30.04.1986 13.07.1977
US 6326053 B1	04.12.2001	AU8257398A1 CA2265773AA JP13500993 JP2001500993T2 US6326053BA W09904099A1 ZA9806293A	10.02.1999 28.01.1999 23.01.2001 23.01.2001 04.12.2001 28.01.1999 17.01.2000
KR 10-1998-0009662 A	30.04.1998	(NONE)	
KR 20-0276464 Y1	11.05.2002	(NONE)	
KR 10-2003-0062947 A	28.07.2003	(NONE)	
JP 11-140810 A	25.05.1999	(NONE)	